

General Description

Qorvo's RFLA1022 is a Low Noise, High Linearity Amplifier housed in a 2.0mm x 2.0mm DFN package. The LNA features a shutdown (SD) pin that can be used to turn off the LNA. The V_{BIAS} (VB) pin can be used to adjust the current of the LNA. Noise figure of 0.45dB and an IIP3 of 27dBm make this component ideal for receiver input lineups. This module is internally matched to 50Ω on all RF ports but does require DC blocks and bias feed inductors.



8 Pin 2X2 mm DFN Package

Product Features

- Frequency Range 400MHz to 1500MHz
- Matched Internally, DC Blocks Required
- Shutdown Mode
- Gain = 17.5dB at 880MHz
- Noise Figure of 0.45dB Typical
- Input IP3 = 27dBm
- Single +3V / +5V Supply
- Small 8-Pin, 2.0mm x 2.0mm DFN

Functional Block Diagram

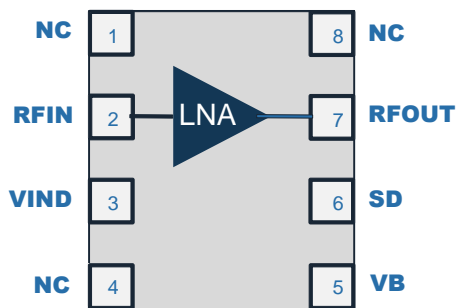

Top View

Applications

- Base-station Receivers
- Repeaters / DAS
- Tower Mounted Amplifiers
- Mobile Infrastructure
- General Purpose Wireless
- TDD or FDD systems

Ordering Information

Part No.	Description
RFLA1022SR	100 pcs on 7" reel
RFLA1022TR7	2500 pcs on 7" reel
RFLA1022PCK-410	Evaluation Board with 5pc sample bag

Absolute Maximum Ratings

Parameter	Rating
Storage Temperature	-65 to 150°C
Supply Voltage (V _{CC})	+5.5 V
RF Input Power, CW, 50Ω, T=25°C	+32 dBm
DC Supply Current	230 mA

Operation of this device outside the parameter ranges given above may cause permanent damage.

Recommended Operating Conditions

Parameter	Min	Typ	Max	Units
Supply Voltage (V _{CC})	3.0	5.0	5.25	V
T _{CASE}	-40		+85	°C
T _j			+150	°C

Electrical specifications are measured at specified test conditions. Specifications are not guaranteed over all recommended operating conditions.

Electrical Specification

Parameter	Condition	Min	Typ	Max	Unit
LNA Performance	V_{CC} = 5V, 140mA, Standard Application Circuit				
Frequency Range		400	880	1500	MHz
Gain (On Mode)	SD = 5V		17.5		dB
Noise Figure			0.45		dB
Input P1dB			5.5		dBm
Input IP3			27		dBm
Gain (Off Mode)	SD = 0V		10		dB
Input Return Loss	SD = 5V		-16		dB
Output Return Loss			-15		dB
LNA Performance	V_{CC} = 3V, 80mA, Standard Application Circuit				
Frequency Range		400		1500	MHz
Gain (On Mode)	SD = 3V		16.5		dB
Noise Figure			0.39		dB
Input P1dB			2.5		dBm
Input IP3			17		dBm
Gain (Off Mode)	SD = 0V		0		dB
Input Return Loss	SD = 3V		-14.5		dB
Output Return Loss			-17		dB
Overall					
SD Voltage	5V Operation	0		V _{CC}	V
Logic High				V _{CC}	V
Logic Low		0			V
SD Voltage	3V Operation	0		V _{CC}	V
Logic High				V _{CC}	V
Logic Low		0			V
Thermal Resistance	85°C at 120mA, 5V		51		°C/W
Current	On Mode, SD = 5V, 5V operation		140		mA
	Off Mode, SD = 0V, 5V operation		1		mA
	On Mode, SD = 3V, 3V operation		80		mA
	Off mode, SD = 0V, 3V operation		1		mA

Typical performance vs V_B Voltage ($V_{CC} = 5V$, 800 MHz, 25°C)

V_B	V	1.1	1.4	2.0	2.6	3.2	3.8	4.2	4.5
Gain	dB	16.42	16.6	16.9	17	17.1	17.2	17.2	17.2
Noise Figure	dB	0.34	0.34	0.35	0.35	0.37	0.40	0.43	0.44
Input IP3	dBm	16.12	14	17.7	21.5	24	28.1	29	27.5
Input P1dB	dBm	-3.2	-1.42	0.96	2.8	4.2	5.4	5.87	6.22
Input Return Loss	dB	-14	-14.5	-15.2	-15.5	-15.6	-15.8	-15.8	-15.9
Output Return Loss	dB	-13	-14	-14.4	-14.8	-15	-15.1	-15.2	-15.2
VCC Current	mA	32	43	65	85	106	126	140	150
SD Current	mA	0.238	0.24	0.23	0.28	0.22	0.22	0.22	0.23
VB Current	mA	0.63	0.89	1.43	1.97	2.5	3.06	3.42	3.68

Typical Performance vs V_B Voltage ($V_{CC} = 3V$, 800 MHz, 25°C)

V_B	V	1.3	1.6	1.9	2.2	2.85	3.0
Gain	dB	16.1	16.3	16.4	16.6	16.7	16.8
Noise Figure	dB	0.36	0.34	0.34	0.35	0.36	0.36
Input IP3	dBm	13.92	13.3	14.2	15.2	15.9	16
Input P1dB	dBm	-2.7	-1.21	0	0.8	2.1	2.2
Input Return Loss	dB	-13	-13.5	-13.8	-14	-14.4	-14.5
Output Return Loss	dB	-14.9	-15.6	-16.1	-16.4	-16.8	-16.9
VCC Current	mA	32	42	52	62	82	88
SD Current	mA	0.11	0.11	0.1	0.1	0.1	0.1
VB Current	mA	0.79	1.06	1.32	1.58	2.2	2.3

Typical Performance vs Frequency ($V_{CC} = 5V$, $V_B = 1.1V$, 25°C)

Frequency	MHz	400	600	800	1000	1200	1500
Gain	dB	22.47	19.37	17.17	15.33	13.76	11.77
Noise Figure	dB	0.28	0.36	0.34	0.42	0.46	0.55
Input IP3	dBm	10.91	13.45	16.12	15.58	15.36	15.73
Input P1dB	dBm	-4.59	-3.47	-3.16	-3.27	-3.2	-3.33
Input Return Loss	dB	-12.8	-13.26	-13.87	-14.38	-14.82	-14.91
Output Return Loss	dB	-17.12	-15.55	-13.68	-12.12	-10.85	-9.43
VCC Current	mA	32	32	32	32	32	32
SD Current	mA	0.23	0.34	0.24	0.23	0.23	0.23
VB Current	mA	0.61	0.61	0.63	0.62	0.63	0.62

Typical Performance vs Frequency ($V_{CC} = 5V$, $25^{\circ}C$, $V_B = 1.4V$)

Frequency	MHz	400	600	800	1000	1200	1500
Gain	dB	22.72	19.58	17.4	15.54	13.97	11.99
Noise Figure	dB	0.26	0.34	0.34	0.41	0.45	0.55
Input IP3	dBm	10.47	12.1	14	15.47	16.84	18.96
Input P1dB	dBm	-3.15	-1.77	-1.42	-1.64	-1.63	-1.71
Input Return Loss	dB	-13.78	-13.93	-14.42	-14.94	-15.34	-15.31
Output Return Loss	dB	-18.94	-16.71	-14.42	-12.66	-11.28	-9.75
VCC Current	mA	43	43	43	43	43	43
SD Current	mA	0.23	0.35	0.23	0.24	0.23	0.23
VB Current	mA	0.88	0.88	0.89	0.89	0.89	0.89

Typical Performance vs Frequency ($V_{CC} = 5V$, $25^{\circ}C$, $V_B = 2.0V$)

Frequency	MHz	400	600	800	1000	1200	1500
Gain	dB	23	19.84	17.63	15.77	14.21	12.25
Noise Figure	dB	0.27	0.34	0.35	0.43	0.47	0.59
Input IP3	dBm	13.77	15.43	17.71	20.21	21.96	21.18
Input P1dB	dBm	-0.69	0.75	0.96	0.91	0.98	0.66
Input Return Loss	dB	-14.94	-14.64	-15.03	-15.53	-15.91	-15.67
Output Return Loss	dB	-20.91	-18.09	-15.27	-13.26	-11.71	-10.13
VCC Current	mA	65	65	65	65	65	65
SD Current	mA	0.22	0.37	0.23	0.23	0.23	0.23
VB Current	mA	1.41	1.41	1.43	1.42	1.42	1.41

Typical Performance vs Frequency ($V_{CC} = 5V$, $25^{\circ}C$, $V_B = 2.6V$)

Frequency	MHz	400	600	800	1000	1200	1500
Gain	dB	23.14	19.96	17.77	15.92	14.35	12.4
Noise Figure	dB	0.27	0.35	0.35	0.44	0.48	0.62
Input IP3	dBm	17.13	19.4	21.5	22.31	21.35	19.41
Input P1dB	dBm	0.8	2.65	2.79	2.77	2.57	2.57
Input Return Loss	dB	-15.59	-15.05	-15.35	-15.8	-16.14	-15.82
Output Return Loss	dB	-21.75	-18.89	-15.69	-13.55	-11.95	-10.32
VCC Current	mA	85	85	85	85	85	85
SD Current	mA	0.22	0.37	0.23	0.24	0.23	0.23
VB Current	mA	1.95	1.96	1.97	1.96	1.96	1.96

Typical Performance vs Frequency ($V_{CC} = 5V$, $25^{\circ}C$, $V_B = 3.2V$)

Frequency	MHz	400	600	800	1000	1200	1500
Gain	dB	23.23	20.04	17.85	15.99	14.44	12.5
Noise Figure	dB	0.28	0.35	0.37	0.47	0.5	0.66
Input IP3	dBm	19.34	21.37	23.98	22.84	21.05	19.09
Input P1dB	dBm	1.42	3.64	4.2	4.3	4.19	4.07
Input Return Loss	dB	-16.01	-15.3	-15.54	-15.98	-16.29	-15.86
Output Return Loss	dB	-22.09	-19.33	-15.94	-13.72	-12.06	-10.43
VCC Current	mA	106	106	106	106	106	106
SD Current	mA	0.22	0.37	0.22	0.23	0.22	0.23
VB Current	mA	2.5	2.5	2.51	2.5	2.51	2.5

Typical Performance vs Frequency ($V_{CC} = 5V$, $25^{\circ}C$, $V_B = 3.8V$)

Frequency	MHz	400	600	800	1000	1200	1500
Gain	dB	23.69	20.1	17.91	16.05	14.53	12.57
Noise Figure	dB	0.3	0.37	0.4	0.48	0.57	0.69
Input IP3	dBm	19.63	20.34	28.06	23.74	22.6	19.78
Input P1dB	dBm	1.73	4.11	5.35	5.5	6.15	5.13
Input Return Loss	dB	-16.32	-15.44	-15.68	-16.09	-16.4	-15.87
Output Return Loss	dB	-22.16	-19.63	-16.1	-13.81	-12.17	-10.5
VCC Current	mA	126	126	126	126	126	126
SD Current	mA	0.22	0.38	0.22	0.22	0.22	0.22
VB Current	mA	3.05	3.06	3.06	3.05	3.41	3.05

Typical Performance vs Frequency ($V_{CC} = 5V$, $25^{\circ}C$, $V_B = 4.2V$)

Frequency	MHz	400	600	800	1000	1200	1500
Gain	dB	23.31	20.12	17.94	16.08	14.53	12.59
Noise Figure	dB	0.32	0.4	0.43	0.51	0.57	0.73
Input IP3	dBm	19.06	19.27	29.04	24.85	22.6	20.53
Input P1dB	dBm	1.9	4.32	5.87	6.29	6.15	6
Input Return Loss	dB	-16.46	-15.53	-15.72	-16.15	-16.40	-15.88
Output Return Loss	dB	-22.13	-19.71	-16.14	-13.83	-12.17	-10.53
VCC Current	mA	140	140	140	140	140	140
SD Current	mA	0.22	0.38	0.22	0.22	0.22	0.22
VB Current	mA	3.41	3.41	3.42	3.41	3.41	3.41

Typical Performance vs Frequency ($V_{CC} = 5V$, $25^{\circ}C$, $V_B = 4.5V$)

Frequency	MHz	400	600	800	1000	1200	1500
Gain	dB	23.32	20.14	17.94	16.09	14.54	12.62
Noise Figure	dB	0.34	0.42	0.44	0.54	0.59	0.75
Input IP3	dBm	18.46	18.57	27.54	25.71	23.56	21.21
Input P1dB	dBm	2	4.48	6.22	6.81	6.68	6.6
Input Return Loss	dB	-16.58	-15.59	-15.77	-16.14	-16.4	-15.87
Output Return Loss	dB	-22.14	-19.82	-16.18	-13.85	-12.16	-10.52
VCC Current	mA	150	150	150	150	150	150
SD Current	mA	0.22	0.38	0.22	0.21	0.22	0.22
VB Current	mA	3.67	3.68	3.69	3.68	3.68	3.68

Typical Performance vs Frequency ($V_{CC} = 3V$, $25^{\circ}C$, $V_B = 1.3V$)

Frequency	MHz	400	600	800	1000	1200	1500
Gain	dB	22.17	19.01	16.81	14.98	13.44	11.51
Noise Figure	dB	0.28	0.35	0.36	0.42	0.46	0.55
Input IP3	dBm	9.25	11.24	13.92	14.78	15.39	16.71
Input P1dB	dBm	-4.91	-3.05	-2.69	-2.63	-2.57	-2.66
Input Return Loss	dB	-12.01	-12.34	-12.86	-13.39	-13.89	-14.19
Output Return Loss	dB	-20.78	-17.48	-15.61	-13.98	-12.65	-11.24
VCC Current	mA	32	32	32	32	32	32
SD Current	mA	0.1	0.21	0.11	0.11	0.1	0.11
VB Current	mA	0.78	0.78	0.79	0.79	0.79	0.8

Typical Performance vs Frequency ($V_{CC} = 3V$, $25^{\circ}C$, $V_B = 1.6V$)

Frequency	MHz	400	600	800	1000	1200	1500
Gain	dB	22.42	19.24	17.03	15.19	13.65	11.73
Noise Figure	dB	0.27	0.34	0.34	0.41	0.46	0.56
Input IP3	dBm	9.17	10.85	13.27	15.34	17.11	19.8
Input P1dB	dBm	-3.69	-1.77	-1.21	-1.16	-1.09	-1.27
Input Return Loss	dB	-12.79	-12.88	-13.32	-13.87	-14.37	-14.61
Output Return Loss	dB	-24.18	-18.82	-16.48	-14.58	-13.11	-11.6
VCC Current	mA	42	42	42	42	42	42
SD Current	mA	0.1	0.22	0.1	0.1	0.1	0.1
VB Current	mA	1.04	1.05	1.06	1.06	1.06	1.06

Typical Performance vs Frequency ($V_{CC} = 3V$, $25^{\circ}C$, $V_B = 1.9V$)

Frequency	MHz	400	600	800	1000	1200	1500
Gain	dB	22.58	19.39	17.19	15.34	13.8	11.88
Noise Figure	dB	0.27	0.34	0.34	0.43	0.45	0.57
Input IP3	dBm	9.74	11.52	14.22	16.82	18.89	20.82
Input P1dB	dBm	-2.86	-0.85	-0.04	-0.07	0.01	-0.07
Input Return Loss	dB	-13.33	-13.22	-13.62	-14.17	-14.69	-14.87
Output Return Loss	dB	-27.15	-19.74	-17	-14.96	-13.4	-11.85
VCC Current	mA	52	52	52	52	52	52
SD Current	mA	0.11	0.22	0.1	0.1	0.1	0.1
VB Current	mA	1.3	1.31	1.32	1.32	1.32	1.33

Typical Performance vs Frequency ($V_{CC} = 3V$, $25^{\circ}C$, $V_B = 2.2V$)

Frequency	MHz	400	600	800	1000	1200	1500
Gain	dB	22.71	19.5	17.3	15.47	13.91	12.19
Noise Figure	dB	0.25	0.34	0.35	0.42	0.47	0.62
Input IP3	dBm	10.14	12.1	15.14	17.84	19.7	18.86
Input P1dB	dBm	-2.49	-0.25	0.8	0.91	0.98	2.63
Input Return Loss	dB	-13.76	-13.51	-13.88	-14.39	-14.92	-15.27
Output Return Loss	dB	-30.55	-20.49	-17.41	-15.19	-13.57	-12.15
VCC Current	mA	62	62	62	62	62	62
SD Current	mA	0.11	0.23	0.1	0.1	0.1	0.1
VB Current	mA	1.57	1.58	1.58	1.58	1.58	2.17

Typical Performance vs Frequency ($V_{CC} = 3V$, $25^{\circ}C$, $V_B = 2.85V$)

Frequency	MHz	400	600	800	1000	1200	1500
Gain	dB	22.88	19.71	17.47	15.64	14.1	12.19
Noise Figure	dB	0.26	0.35	0.36	0.44	0.5	0.62
Input IP3	dBm	9.92	11.97	15.89	18.65	19.6	18.86
Input P1dB	dBm	-2.12	0.43	2.06	2.42	2.67	2.63
Input Return Loss	dB	-14.42	-14.02	-14.27	-14.79	-15.27	-15.27
Output Return Loss	dB	-36.47	-21.73	-17.93	-15.48	-13.77	-12.15
VCC Current	mA	82	82	82	82	82	82
SD Current	mA	0.1	0.24	0.1	0.1	0.09	0.1
VB Current	mA	2.16	2.31	2.16	2.17	2.17	2.17

Typical Performance vs Frequency ($V_{CC} = 3V$, $25^{\circ}C$, $V_B = 3.0V$)

Frequency	MHz	400	600	800	1000	1200	1500
Gain	dB	22.92	19.71	17.52	15.65	14.13	12.23
Noise Figure	dB	0.27	0.35	0.36	0.44	0.48	0.63
Input IP3	dBm	9.79	11.97	15.95	18.81	19.62	18.87
Input P1dB	dBm	-2.07	0.43	2.24	2.85	3.04	3.08
Input Return Loss	dB	-14.54	-14.02	-14.3	-14.88	-15.35	-15.32
Output Return Loss	dB	-36.48	-21.73	-18.03	-15.52	-13.8	-12.16
VCC Current	mA	88	88	88	88	88	88
SD Current	mA	0.1	0.24	0.1	0.09	0.1	0.1
VB Current	mA	2.29	2.31	2.3	2.3	2.31	2.31

Typical Performance Plots (5V, 140mA and 3V, 80mA)

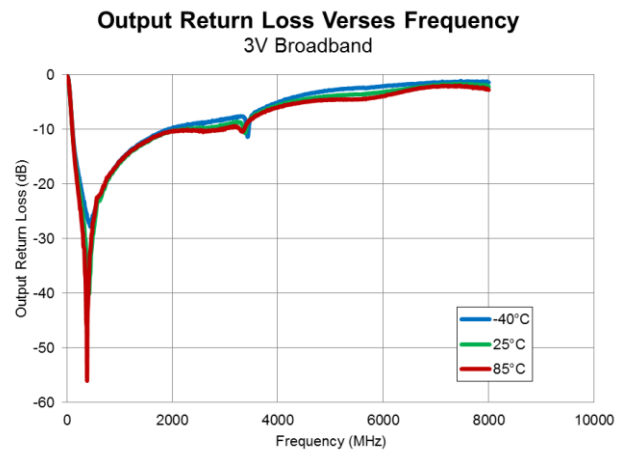
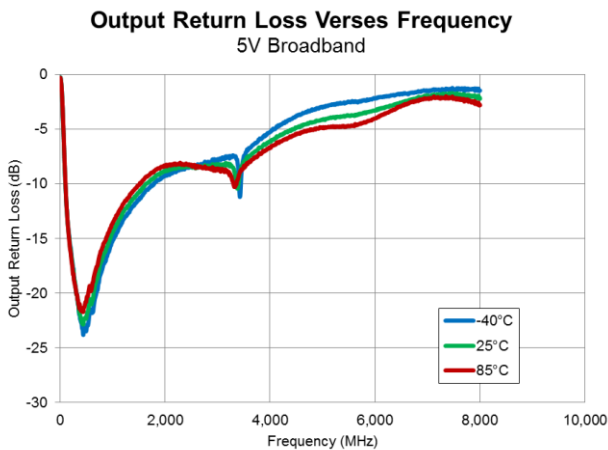
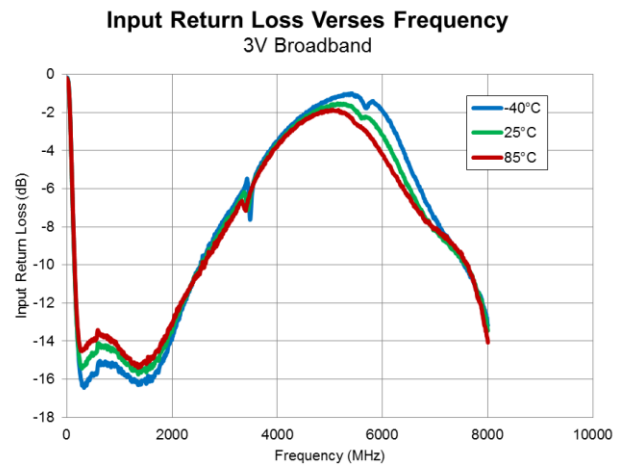
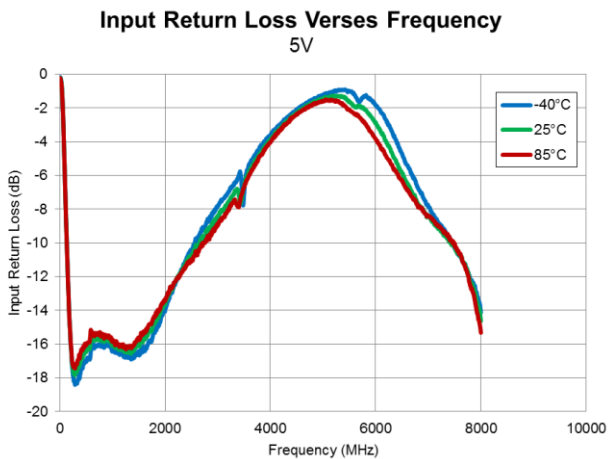
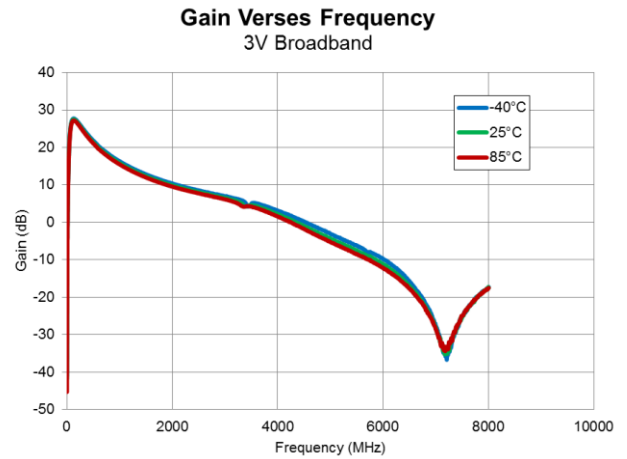
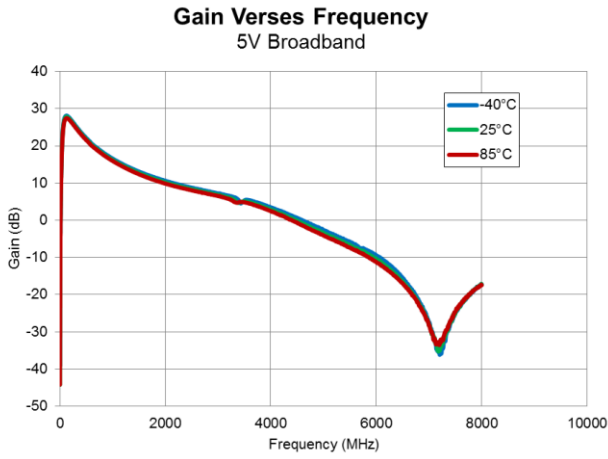

Typical Performance Plots (5V, 140mA and 3V, 80mA)

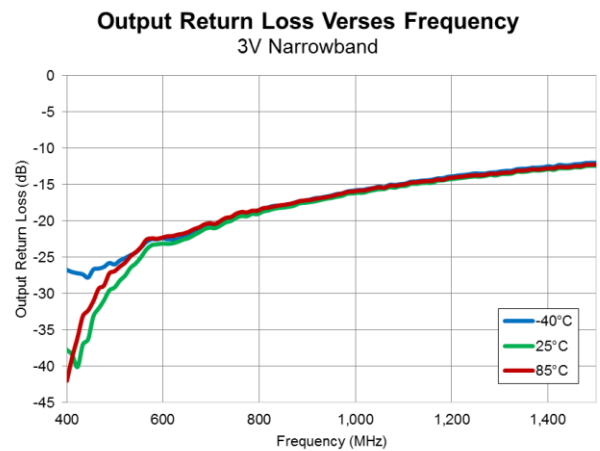
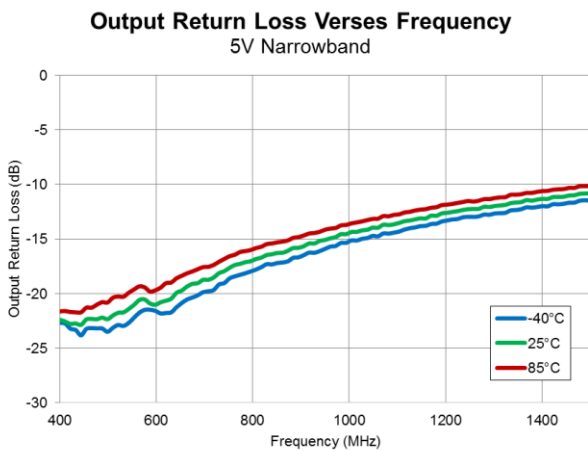
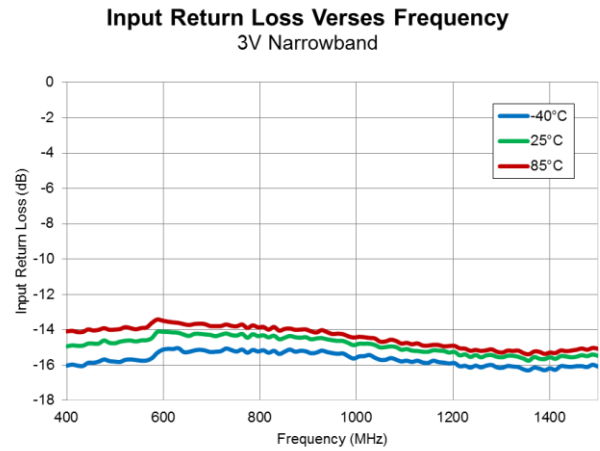
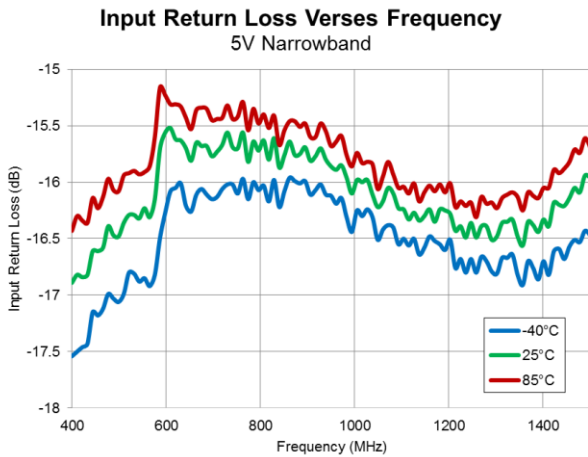
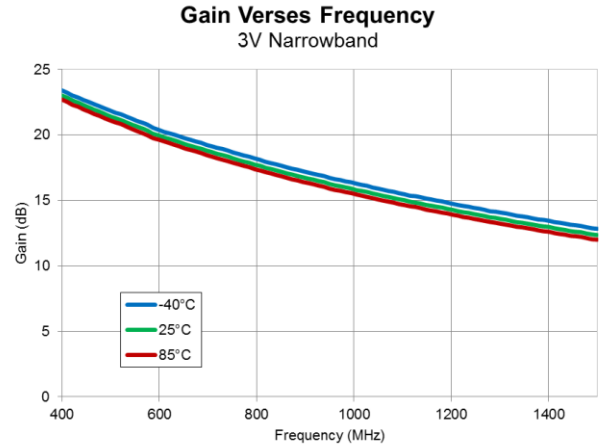
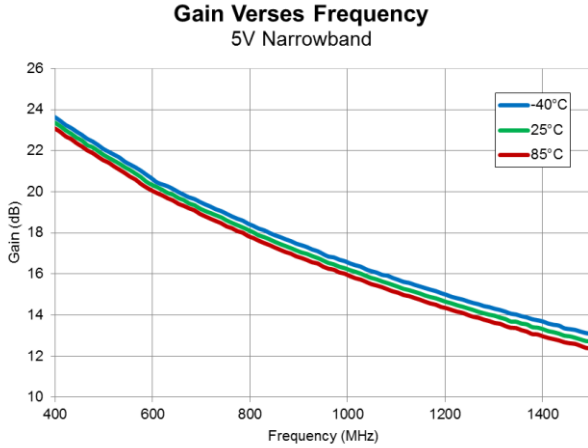

Typical Performance Plots (5V, 140mA and 3V, 80mA)

Input P1dB versus Frequency
5V

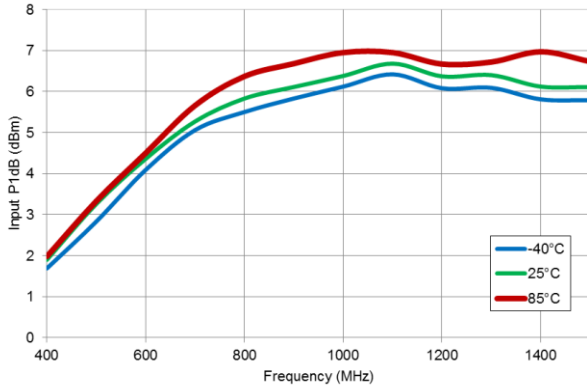

Input P1dB versus Frequency
3V

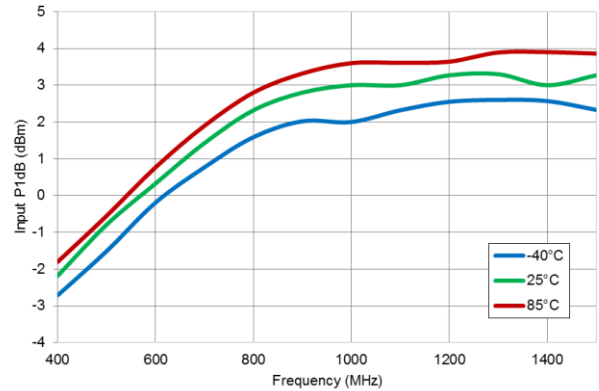

Input IP3 versus Frequency
5V

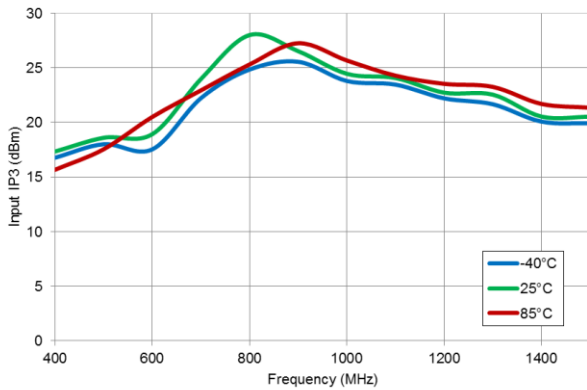

Input IP3 versus Frequency
3V

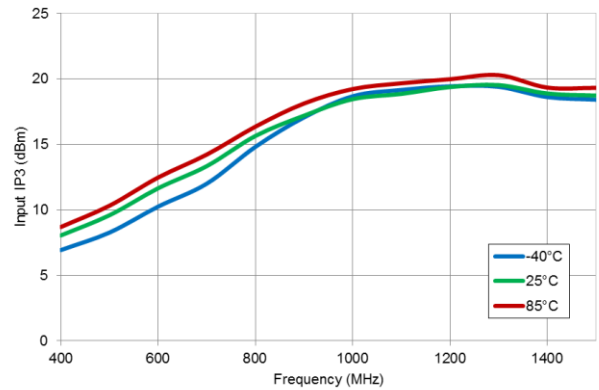

Noise Figure versus Temperature
5V

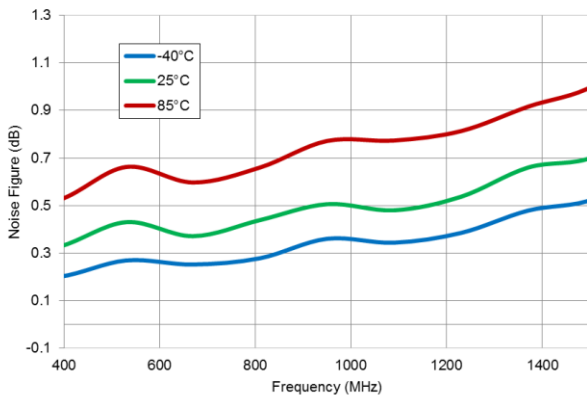

Noise Figure versus Temperature
3V

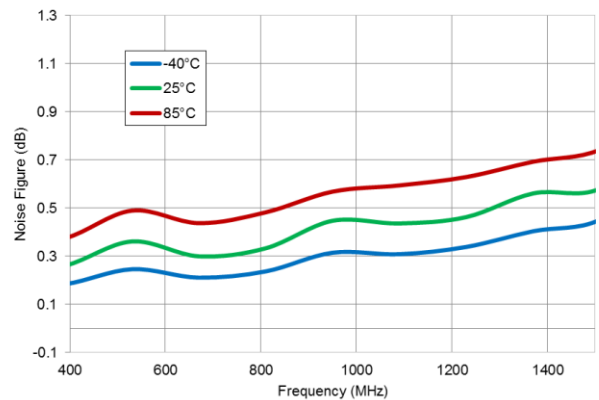

Typical Performance Plots (5V, 140mA and 3V, 80mA)

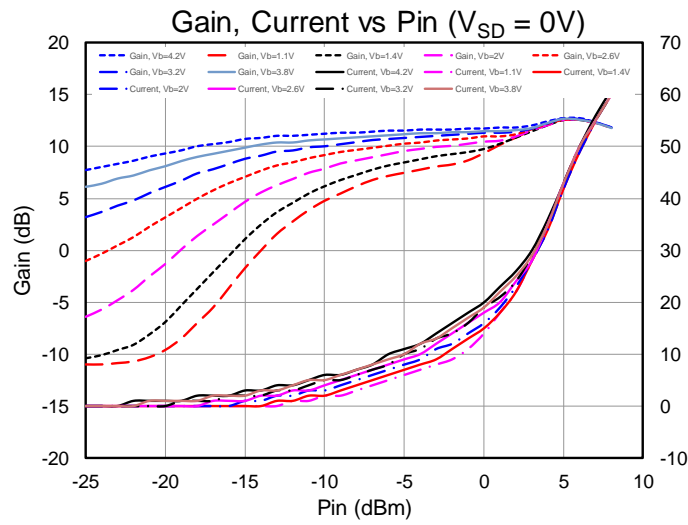
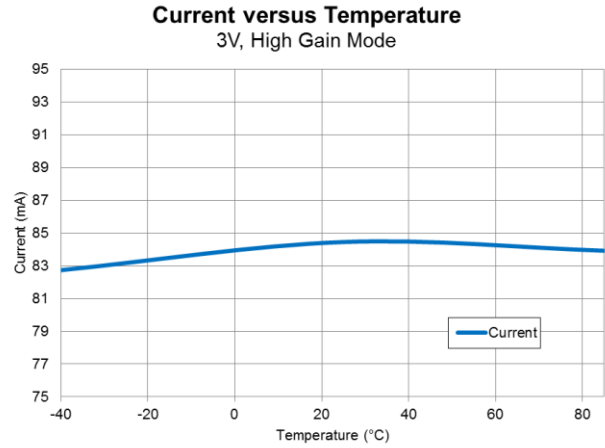
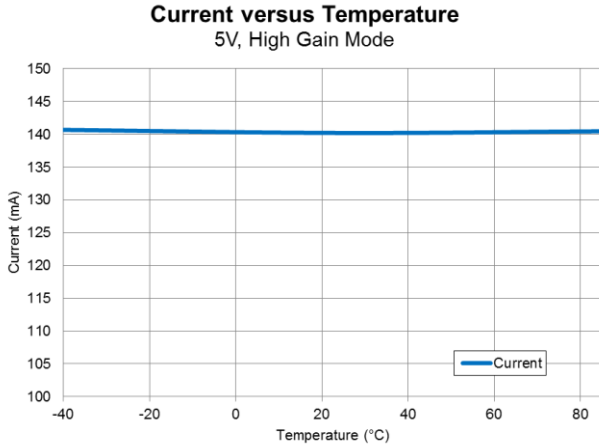

RFLA1022 Evaluation Board

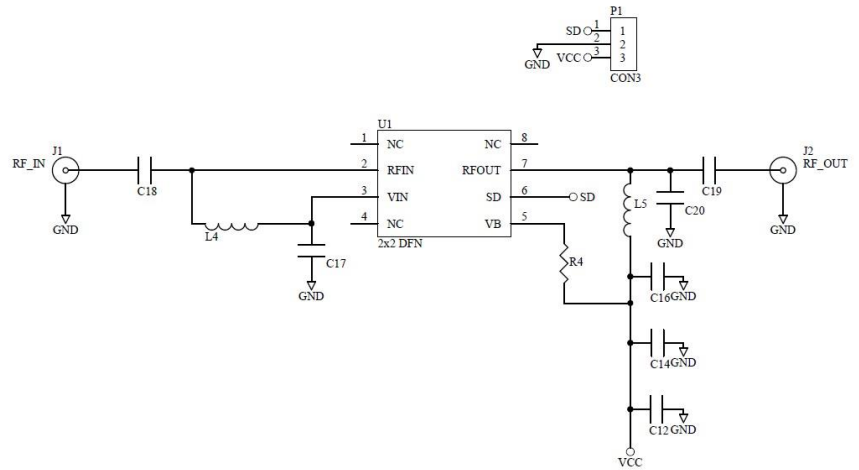
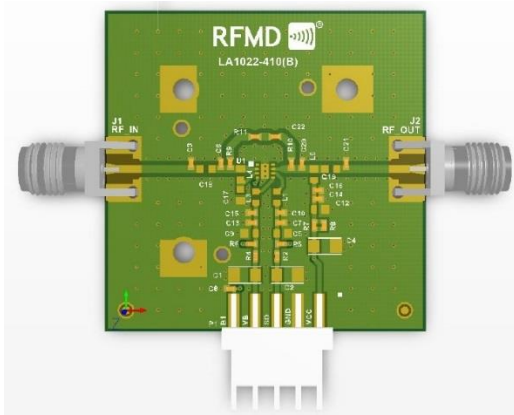

Bill of Material – RFLA1022 Evaluation Board

Reference Des.	Value	Description	Manuf.	Part Number
N/A	N/A	Printed Circuit Board	Qorvo	
U1		Low Noise, High Linearity LNA	Qorvo	RFLA1022
C14, C17	0.1 uF	CAP, 10%, 16v, X7R, 0402	Murata	GRM155R71C104KA88D
C16	10 pF	CAP, 5%, 50V, C0G, 0402	Murata	GRM1555C1H100JA01D
C4	22 uF	CAP, 10%, 10V, TANT-A	AVX	TAJA226K010RNJ
C18, C19	10000pF	CAP, 10%, 50V, X7R, 0603	Murata	GRM188R71H103KA01D
C20	1.0 pF	CAP, ±0.25pF, 50V, COG, 0402	Murata	GRM1555C1HR0CA01D
R4	0 Ω	RES, 0Ω, 0402	various	
L4, L5	82 nH	IND, 5%, W/W, 0603	Coilcraft	0603CS-82NXJLW
J1, J6		CONN, SMA, END LNCH, UNIV, HYB MNT, FLT	Various	
P1		CONN, HDR, ST, PLRZD, 4-PIN	Various	

Pin Configuration and Description

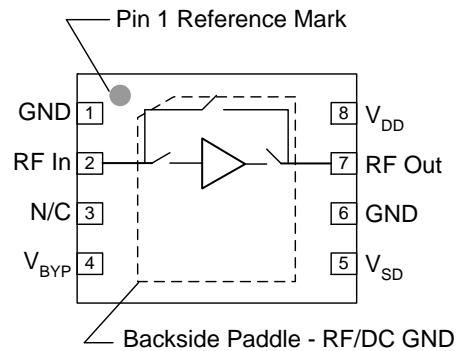

Pin No.	Label	Description
1	NC	No connect
2	RFIN	RF Input; Internally 50Ω matched, DC block required
3	VIND	External gate bias fed through a choke inductor to pin 2
4	NC	No connect
5	VB	Bias voltage
6	SD	Shutdown pin to turn off the LNA
7	RFOUT	RF Output; Internally 50Ω matched, DC block required
8	NC	No connect

Mechanical Information

Package Marking and Dimensions

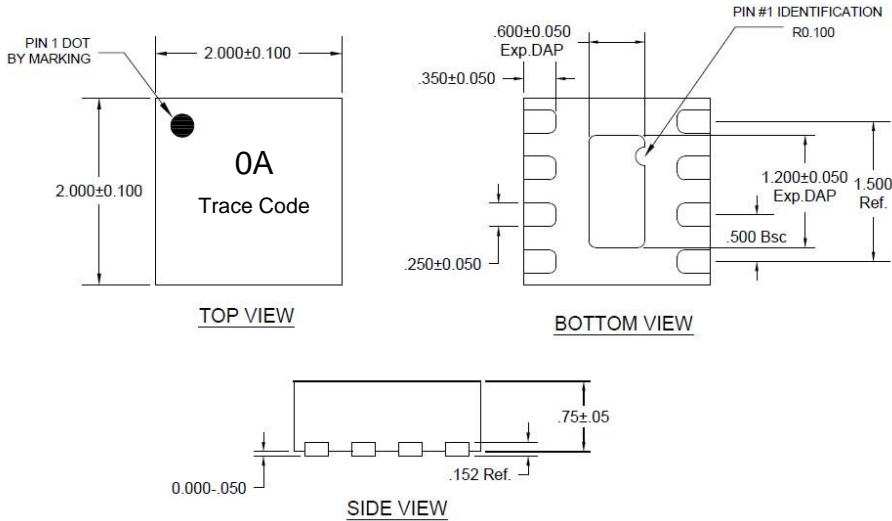

Notes:

1. All dimensions are in millimeters. Angles are in degrees.
2. Except where noted, this part outline conforms to JEDEC standard MO-220, Issue E (Variation VGGC) for thermally enhanced plastic very thin fine pitch quad flat no lead package (QFN).
3. Dimension and tolerance formats conform to ASME Y14.4M-1994.
4. The terminal #1 identifier and terminal numbering conform to JESD 95-1 SPP-012.

PCB Mounting Pattern

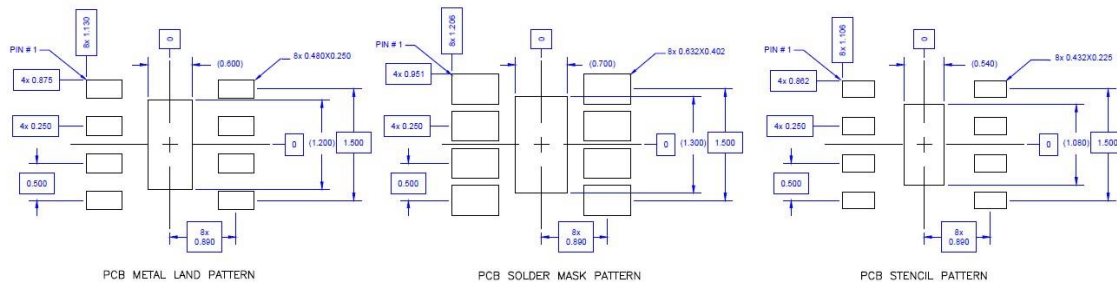

Thermal vias for center slug should be incorporated into the PCB design. The number and size of thermal vias will depend on the application, the power dissipation, and the electrical requirements. Example of the number and size of vias can be found on the RFMD evaluation board layout.

Notes:

1. All dimensions are in millimeters. Angles are in degrees.
2. Use 1 oz. copper minimum for top and bottom layer metal.
3. Vias are required under the backside paddle of this device for proper RF/DC grounding and thermal dissipation. We recommend a 0.35mm (#80/.0135") diameter bit for drilling via holes and a final plated thru diameter of 0.25 mm (0.10").
4. Ensure good package backside paddle solder attach for reliable operation and best electrical performance.

Handling Precautions

Parameter	Rating	Standard
ESD – Human Body Model (HBM)	Class 1A	ESDA / JEDEC JS-001-2014
ESD – Charged Device Model (CDM)	Class C3	ESDA / JEDEC JS-002-2014
MSL – Moisture Sensitivity Level	Level 1	IPC/JEDEC J-STD-020



Caution!
ESD-Sensitive Device

Solderability

Compatible with lead-free (260°C max. reflow temp.) soldering process.
Solder profiles available upon request.

Contact plating: Matte Tin

RoHS Compliance

This part is compliant with 2011/65/EU RoHS directive (Restrictions on the Use of Certain Hazardous Substances in Electrical and Electronic Equipment) as amended by Directive 2015/863/EU.

This product also has the following attributes:

- Lead Free
- Halogen Free (Chlorine, Bromine)
- Antimony Free
- TBBP-A (C₁₅H₁₂Br₄O₂) Free
- PFOS Free
- SVHC Free



Contact Information

For the latest specifications, additional product information, worldwide sales and distribution locations:

Web: www.qorvo.com

Tel: 1-844-890-8163

Email: customer.support@qorvo.com

For technical questions and application information: **Email:** appsupport@qorvo.com

Important Notice

The information contained herein is believed to be reliable; however, Qorvo makes no warranties regarding the information contained herein and assumes no responsibility or liability whatsoever for the use of the information contained herein. All information contained herein is subject to change without notice. Customers should obtain and verify the latest relevant information before placing orders for Qorvo products. The information contained herein or any use of such information does not grant, explicitly or implicitly, to any party any patent rights, licenses, or any other intellectual property rights, whether with regard to such information itself or anything described by such information. **THIS INFORMATION DOES NOT CONSTITUTE A WARRANTY WITH RESPECT TO THE PRODUCTS DESCRIBED HEREIN, AND QORVO HEREBY DISCLAIMS ANY AND ALL WARRANTIES WITH RESPECT TO SUCH PRODUCTS WHETHER EXPRESS OR IMPLIED BY LAW, COURSE OF DEALING, COURSE OF PERFORMANCE, USAGE OF TRADE OR OTHERWISE, INCLUDING THE IMPLIED WARRANTIES OF MERCHANTABILITY AND FITNESS FOR A PARTICULAR PURPOSE.**

Without limiting the generality of the foregoing, Qorvo products are not warranted or authorized for use as critical components in medical, life-saving, or life-sustaining applications, or other applications where a failure would reasonably be expected to cause severe personal injury or death.

Copyright 2017 © Qorvo, Inc. | Qorvo is a registered trademark of Qorvo, Inc.

Looking for pricing, stock, or lifecycle information?

Click below to explore more details on WIN SOURCE:

 [View RFLA1022TR7 on WIN SOURCE](#)

 [Qorvo US Inc. Information](#)

Optimize Your Supply Chain with WIN SOURCE Solutions

-  Global Sourcing Solution
-  Obsolete Management
-  Cost Control Management
-  Shortage Management
-  Alternative Solution
-  Excess Inventory Management