

Low Noise Amplifier with Bypass for 5 GHz band

■ FEATURES

- Wide frequency range 4900MHz to 5950MHz
- Low operating voltage 1.5V to 3.3 V
- Low current 5.0/3.5mA typ. @ $V_{DD}=2.8/1.8V$
- High gain
15.0dB typ. @ $V_{DD}=2.8V, f_{RF}=5500\text{ MHz}$
- Low noise figure
1.1dB typ. @ $V_{DD}=2.8V, f_{RF}=5500\text{ MHz}$
- High IIP3
+2.0dBm typ. @ $V_{DD}=2.8V, f_{RF}=5500\text{ MHz}+5501\text{ MHz}$
- Low insertion loss (bypass mode)
3.5dB typ. @ $V_{DD}=2.8V, f_{RF}=5500\text{ MHz}$
- Ultra-small package size 1.1 x 0.7 x 0.37mm typ.
- RoHS compliant and Halogen Free, MSL1

■ APPLICATION

- LTE-U/LAA receive application
- WiMAX 5GHz receive application
- WLAN 5GHz receive application
- RF front-end modules, data cards, and other mobile applications

■ BLOCK DIAGRAM (EPFFP6-X2)

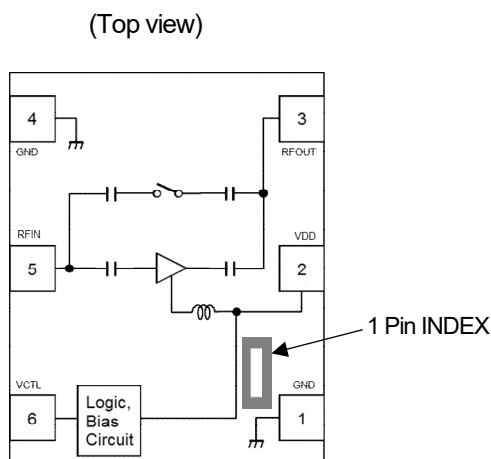

■ GENERAL DESCRIPTION

NJG1182UX2 is low noise amplifier with bypass switch for 5GHz application such as LTE-U/LAA, which covers frequency from 4900MHz to 5950MHz.

NJG1182UX2 is able to select LNA active mode or bypass mode by low control voltage. This LNA achieves low noise figure and high linearity.

Integrated ESD protection device on each port achieves excellent ESD robustness.

A very small and ultra-thin package EPFFP6-X2 is adopted.

■ TRUTH TABLE

“H”= $V_{CTL(H)}$, “L”= $V_{CTL(L)}$

V_{CTL}	Mode
H	LNA active mode
L	Bypass mode

■ PIN CONFIGURATION

PIN NO.	SYMBOL	DESCRIPTION
1	GND	Ground
2	VDD	Power supply
3	RFOUT	RF output
4	GND	Ground
5	RFIN	RF input
6	VCTL	Control voltage

■ PRODUCT NAME INFORMATION

NJG1182 UX2 (TE1)
 | | |
 Part number Package Taping form

■ ORDERING INFORMATION

PART NUMBER	PACKAGE OUTLINE	RoHS	HALOGEN-FREE	TERMINAL FINISH	MARKING	WEIGHT (mg)	MOQ (pcs.)
NJG1182UX2	EPFFP6-X2	Yes	Yes	Ni/Pd/Au	5	0.7	5,000

■ ABSOLUTE MAXIMUM RATINGS

$T_a = 25^\circ\text{C}, Z_s = Z_l = 50 \Omega$

PARAMETER	SYMBOL	RATINGS	UNIT
Operating voltage	V_{DD}	5.0	V
Control voltage	V_{CTL}	5.0	V
Input power	P_{IN}	+15 ⁽¹⁾	dBm
Power dissipation	P_D	430 ⁽²⁾	mW
Operating temperature	T_{opr}	-40 to +105	°C
Storage temperature	T_{stg}	-55 to +150	°C

(1): $V_{DD}=2.8\text{V}$

(2): 4-layer FR4 PCB with through-hole (101.5x114.5mm), $T_f=150^\circ\text{C}$

■ ELECTRICAL CHARACTERISTICS 1 (DC)

General condition: $T_a=+25^\circ\text{C}$, with application circuit

PARAMETER	SYMBOL	TEST CONDITION	MIN.	TYP.	MAX.	UNIT
Operating voltage	V_{DD}		1.5	-	3.3	V
Control voltage (High)	$V_{CTL(H)}$		1.3	1.8	3.3	V
Control voltage (Low)	$V_{CTL(L)}$		0	0	0.3	V
Operating current 1	I_{DD1}	RF OFF, $V_{DD}=2.8\text{V}, V_{CTL}=1.8\text{V}$	-	5.0	8.0	mA
Operating current 2	I_{DD2}	RF OFF, $V_{DD}=1.8\text{V}, V_{CTL}=1.8\text{V}$	-	3.5	8.0	mA
Operating current 3	I_{DD3}	RF OFF, $V_{DD}=2.8\text{V}, V_{CTL}=0\text{V}$	-	20	60	μA
Operating current 4	I_{DD4}	RF OFF, $V_{DD}=1.8\text{V}, V_{CTL}=0\text{V}$	-	10	60	μA
Control current	I_{CTL}	RF OFF, $V_{CTL}=1.8\text{V}$	-	7	20	μA

■ ELECTRICAL CHARACTERISTICS 2 (LNA active mode)

General condition: $V_{DD}=2.8V$, $V_{CTL}=1.8V$, $f_{RF}=5500MHz$, $T_a=+25^{\circ}C$, $Z_s=Z_l=50\Omega$, with application circuit

PARAMETER	SYMBOL	TEST CONDITION	MIN.	TYP.	MAX.	UNIT
Small signal gain1	Gain1	Exclude PCB & connector losses *1	12.0	15.0	17.5	dB
Noise figure1	NF1	Exclude PCB & connector losses *2	-	1.1	1.7	dB
Input power at 1dB gain compression point1(1)	P-1dB(IN)1(1)		-16.0	-11.0	-	dBm
Input 3rd order intercept point1(1)	IIP3_1(1)	$f1=f_{RF}$, $f2=f_{RF}+1MHz$, $P_{IN}=-30dBm$	-5.0	+2.0	-	dBm
RF IN return loss1(1)	RLi1(1)		8.0	16.0	-	dB
RF OUT return loss1(1)	RLo1(1)		5.0	8.0	-	dB
Gain settling time1(1)	Ts1(1)	Bypass to LNA active mode to be within 1 dB of the final gain	-	1.0	2.5	μs
Gain settling time1(2)	Ts1(2)	LNA active to Bypass mode to be within 1 dB of the final insertion loss	-	0.8	2.5	μs

*1: PCB and connector losses: 0.64 dB

*2: PCB and connector losses: 0.30 dB

■ ELECTRICAL CHARACTERISTICS 3 (Bypass mode)

General condition: $V_{DD}=2.8V$, $V_{CTL}=0V$, $f_{RF}=5500MHz$, $T_a=+25^{\circ}C$, $Z_s=Z_l=50\Omega$, with application circuit

PARAMETER	SYMBOL	TEST CONDITION	MIN.	TYP.	MAX.	UNIT
Insertion Loss1	Loss1	Exclude PCB & connector losses *1	-	3.5	5.0	dB
Input power at 1dB compression point1(2)	P-1dB(IN)1(2)		+2.0	+7.5	-	dBm
Input 3rd order intercept point1(2)	IIP3_1(2)	$f1=f_{RF}$, $f2=f_{RF}+1MHz$, $P_{IN}=-10dBm$	+10.0	+18.0	-	dBm
RF IN return loss1(2)	RLi1(2)		6.0	13.0	-	dB
RF OUT return loss1(2)	RLo1(2)		4.0	6.0	-	dB

*1: PCB and connector losses: 0.64 dB

■ ELECTRICAL CHARACTERISTICS 4 (LNA active mode)

General condition: $V_{DD}=1.8V$, $V_{CTL}=1.8V$, $f_{RF}=5500MHz$, $T_a=+25^{\circ}C$, $Z_s=Z_l=50\Omega$, with application circuit

PARAMETER	SYMBOL	TEST CONDITION	MIN.	TYP.	MAX.	UNIT
Small signal gain ²	Gain ²	Exclude PCB & connector losses ^{*1}	-	14.5	-	dB
Noise figure ²	NF ²	Exclude PCB & connector losses ^{*2}	-	1.4	-	dB
Input power at 1dB gain compression point ² (1)	P-1dB(IN) 2(1)			-13.0		dBm
Input 3rd order intercept point ² (1)	IIP3_2(1)	$f_1=f_{RF}$, $f_2=f_{RF}+1MHz$, $P_{IN}=-30dBm$	-	-1.0	-	dBm
RF IN return loss ² (1)	RLi ² (1)		-	11.0	-	dB
RF OUT return loss ² (1)	RLo ² (1)		-	8.0	-	dB
Gain settling time ² (1)	Ts ² (1)	Bypass to LNA active mode To be within 1 dB of the final gain	-	2.0	-	μs
Gain settling time ² (2)	Ts ² (2)	LNA active to Bypass mode To be within 1 dB of the final insertion loss	-	0.8	-	μs

*1: PCB and connector losses: 0.64 dB

*2: PCB and connector losses: 0.30 dB

■ ELECTRICAL CHARACTERISTICS 5 (Bypass mode)

General condition: $V_{DD}=1.8V$, $V_{CTL}=0V$, $f_{RF}=5500MHz$, $T_a=+25^{\circ}C$, $Z_s=Z_l=50\Omega$, with application circuit

PARAMETER	SYMBOL	TEST CONDITION	MIN.	TYP.	MAX.	UNIT
Insertion Loss ²	Loss ²	Exclude PCB & connector losses ^{*1}	-	3.5	-	dB
Input power at 1dB compression point ² (2)	P-1dB(IN) 2(2)		-	+7.0	-	dBm
Input 3rd order intercept point ² (2)	IIP3_2(2)	$f_1=f_{RF}$, $f_2=f_{RF}+1MHz$, $P_{IN}=-10dBm$	-	+18.0	-	dBm
RF IN return loss ² (2)	RLi ² (2)		-	13.0	-	dB
RF OUT return loss ² (2)	RLo ² (2)		-	7.0	-	dB

*1: PCB and connector losses: 0.64 dB

ELECTRICAL CHARACTERISTICS (LNA active mode)

Conditions: $V_{DD}=2.8V$, $V_{CTL}=1.8V$, $f_{RF}=5500MHz$, $T_a=+25^{\circ}C$, $Z_s=Z_l=50\Omega$, with application circuit

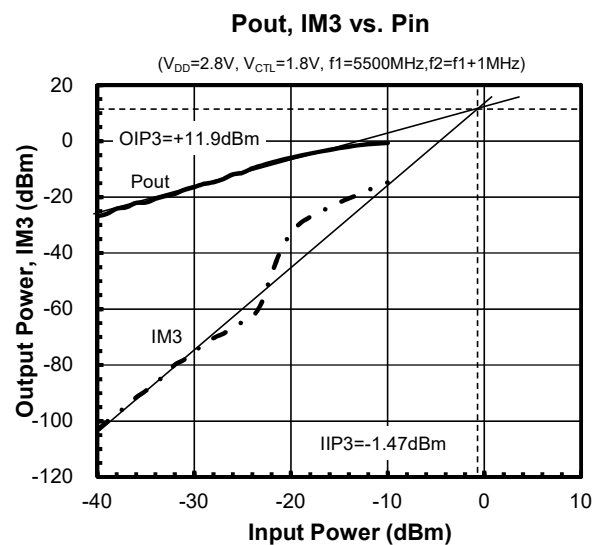
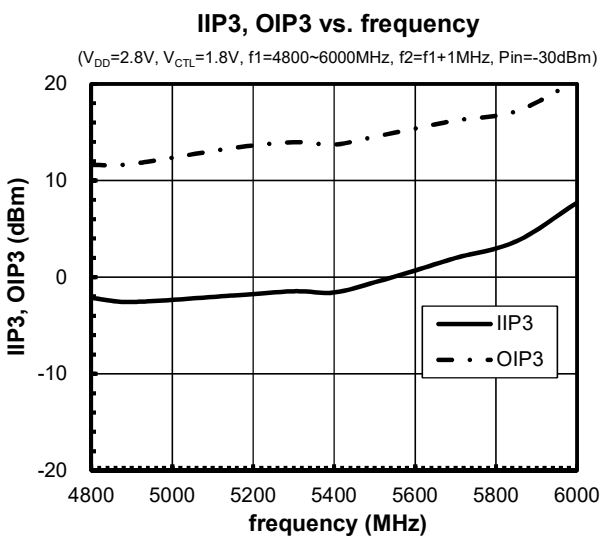
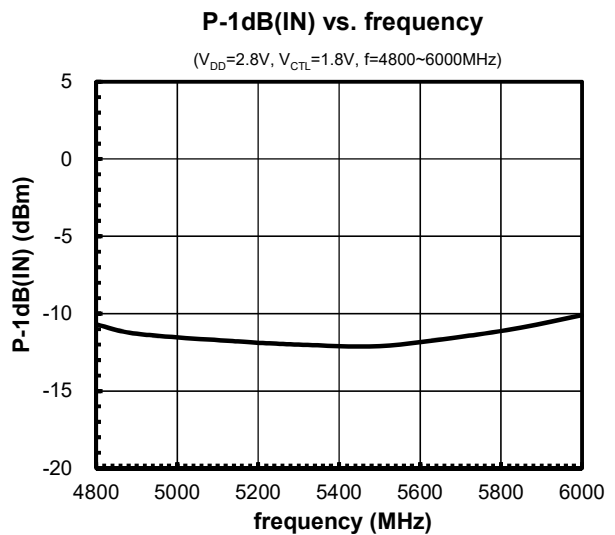
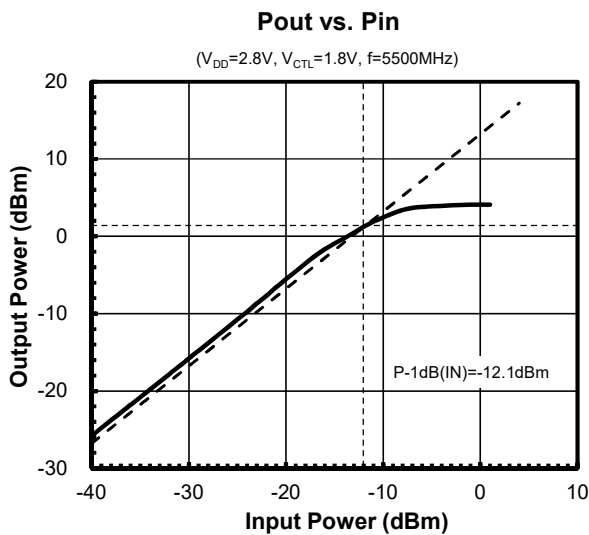
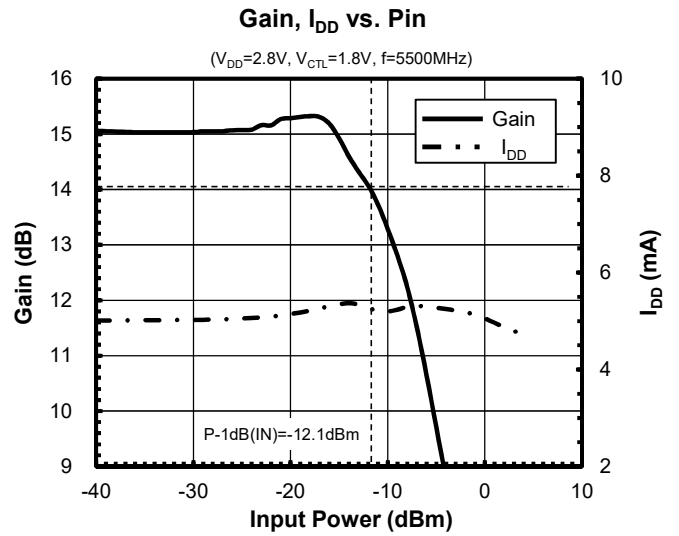
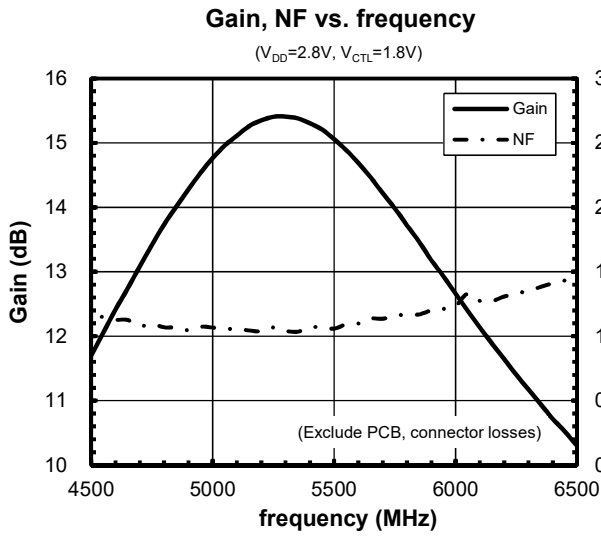

■ ELECTRICAL CHARACTERISTICS (LNA active mode)

Conditions: $V_{DD}=2.8V$, $V_{CTL}=1.8V$, $f_{RF}=50MHz$ to $10000MHz$, $T_a=+25^{\circ}C$, $Z_S=Z_L=50\Omega$, with application circuit

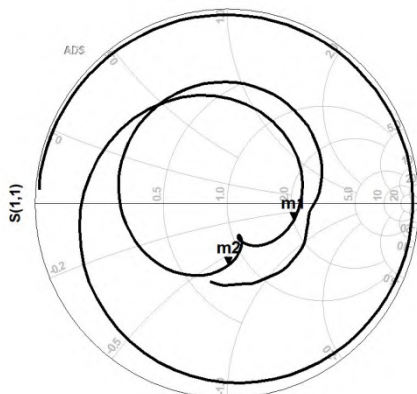
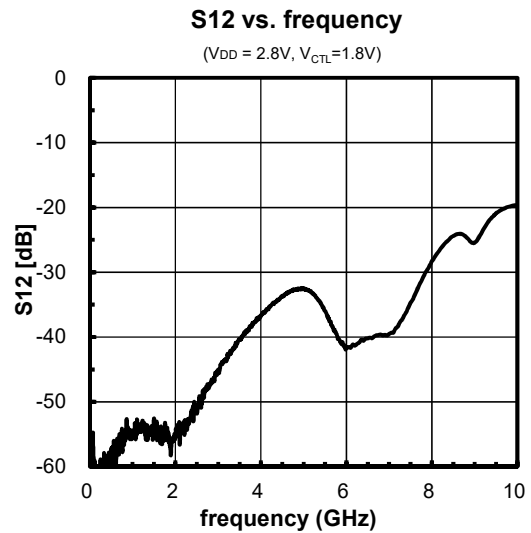
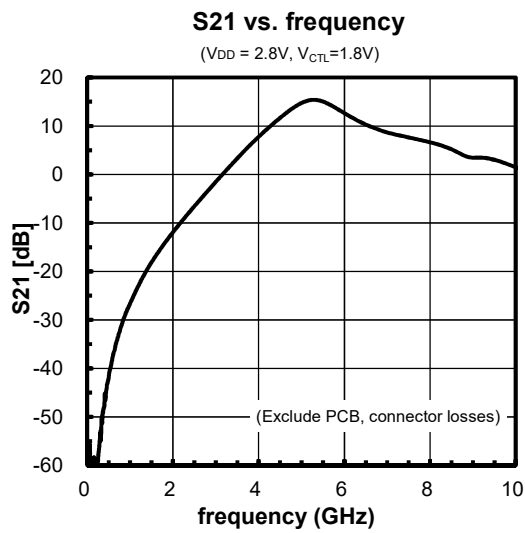
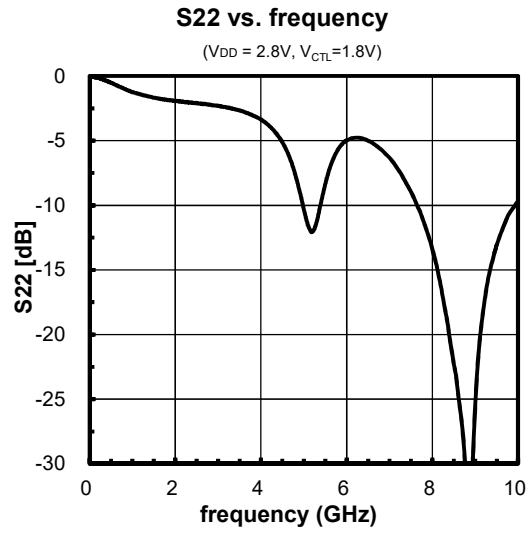
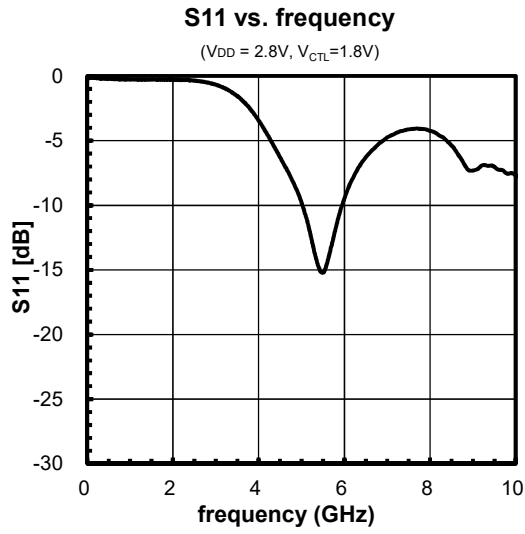

freq (50.00MHz to 10.00GHz)

m1
freq=4.900GHz
 $S(1,1)=0.358 / -14.219$
impedance = $Z_0 * (2.010 - j0.406)$

m2
freq=5.950GHz
 $S(1,1)=0.317 / -88.662$
impedance = $Z_0 * (0.828 - j0.585)$

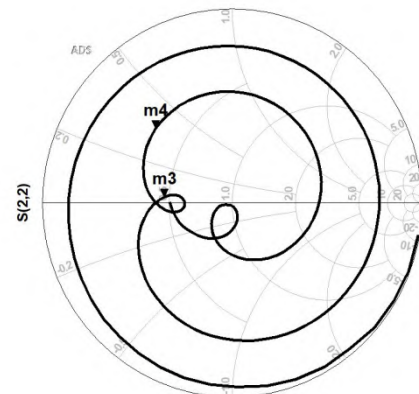

freq (50.00MHz to 10.00GHz)

m3
freq=4.900GHz
 $S(2,2)=0.360 / 175.137$
impedance = $Z_0 * (0.472 + j0.033)$

m4
freq=5.950GHz
 $S(2,2)=0.558 / 136.434$
impedance = $Z_0 * (0.325 + j0.363)$

■ ELECTRICAL CHARACTERISTICS (Bypass mode)

Conditions: $V_{DD}=2.8V$, $V_{CTL}=0V$, $f_{RF}=5500MHz$, $T_a=+25^{\circ}C$, $Z_s=Z_l=50\Omega$, with application circuit

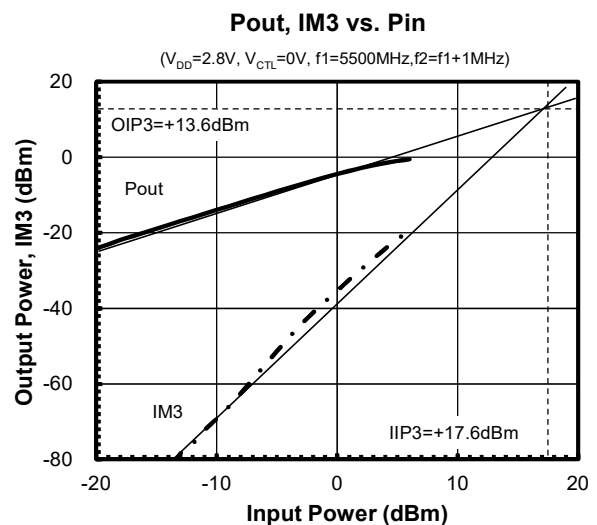
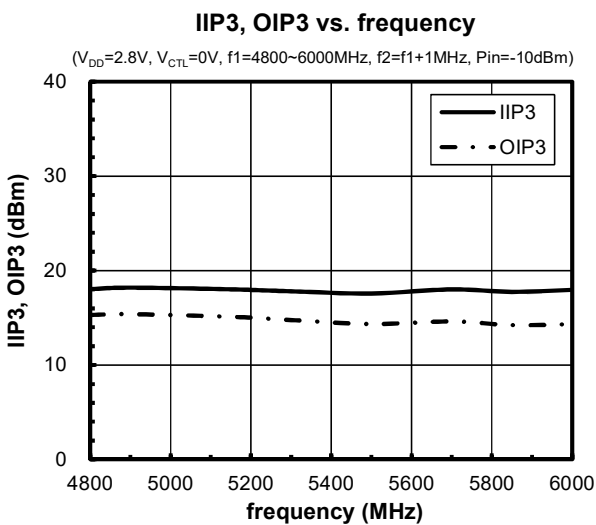
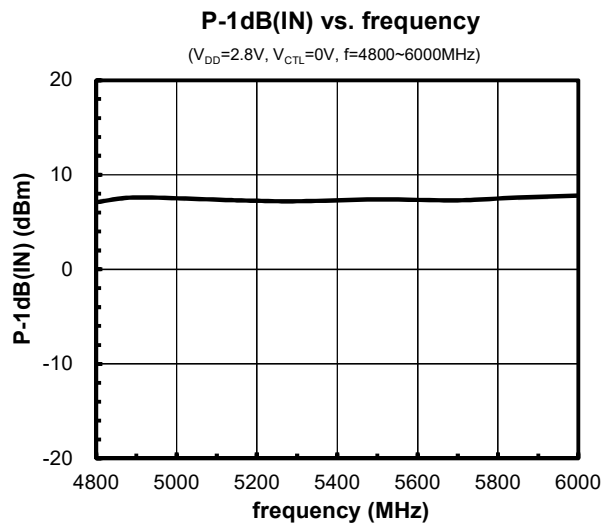
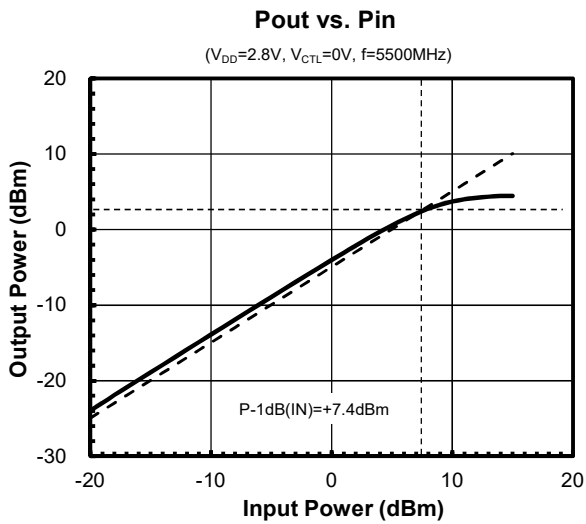
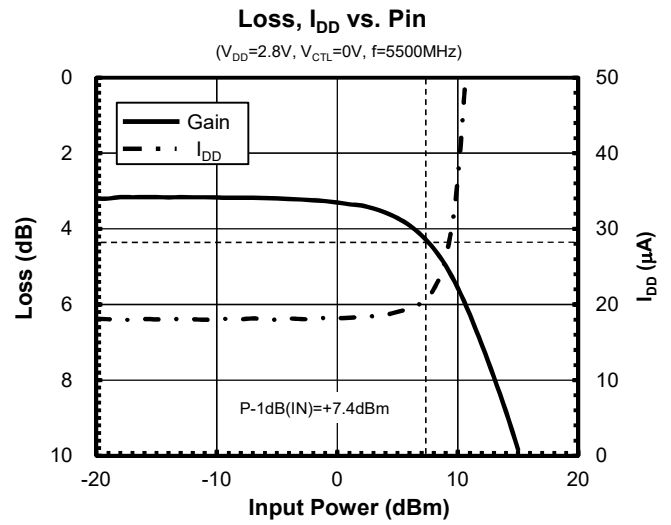
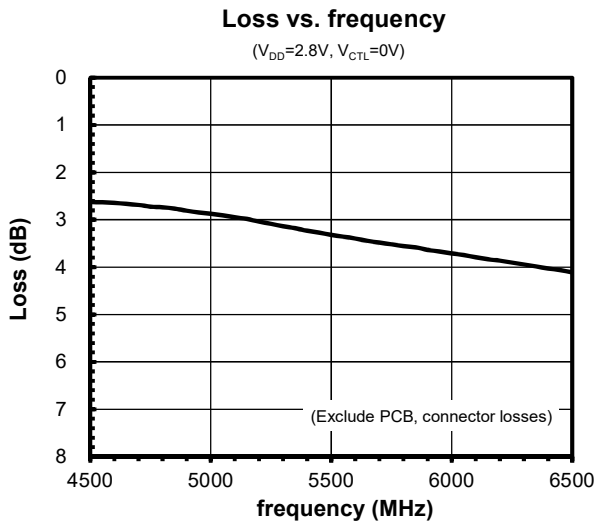

■ ELECTRICAL CHARACTERISTICS (Bypass mode)

Conditions: $V_{DD}=2.8V$, $V_{CTL}=0V$, $f_{RF}=50MHz$ to $10000MHz$, $T_a=+25^{\circ}C$, $Z_S=Z_L=50\Omega$, with application circuit

S11 vs. frequency

($V_{DD} = 2.8V$, $V_{CTL}=0V$)

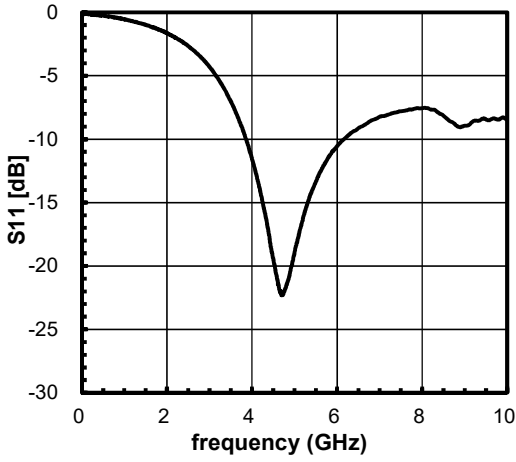

S22 vs. frequency

($V_{DD} = 2.8V$, $V_{CTL}=0V$)

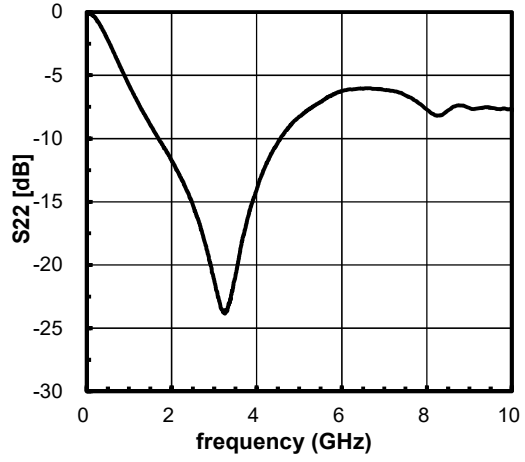

S21 vs. frequency

($V_{DD} = 2.8V$, $V_{CTL}=0V$)

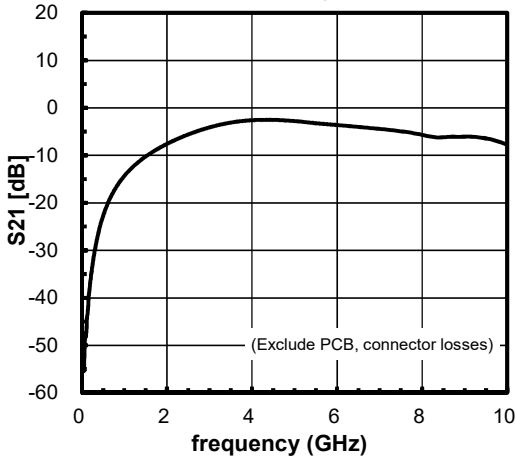

S12 vs. frequency

($V_{DD} = 2.8V$, $V_{CTL}=0V$)

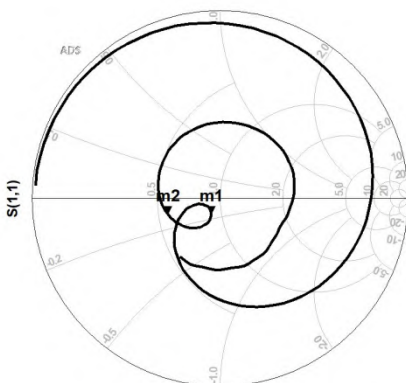
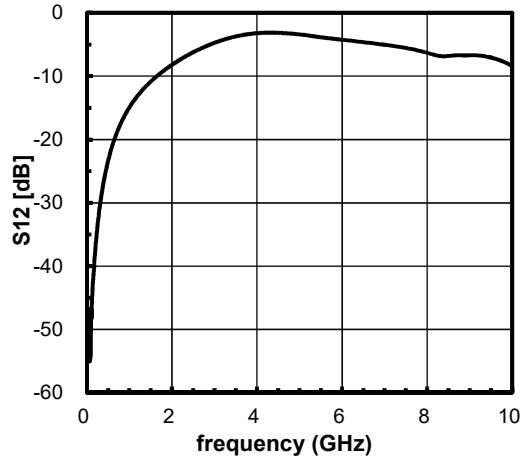

freq (50.00MHz to 10.00GHz)

m1
freq=4.900GHz
S(1,1)=0.095 / -119.355
impedance = $Z_0 * (0.899 - j0.151)$

m2
freq=5.950GHz
S(1,1)=0.290 / -163.234
impedance = $Z_0 * (0.559 - j0.102)$

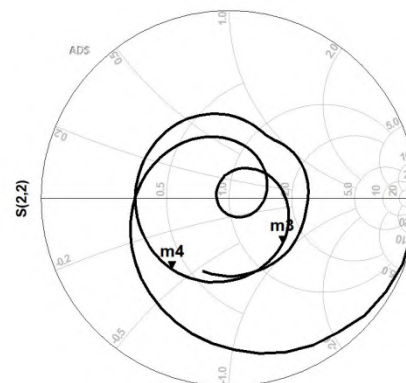

freq (50.00MHz to 10.00GHz)

m3
freq=4.900GHz
S(2,2)=0.373 / -40.290
impedance = $Z_0 * (1.510 - j0.846)$

m4
freq=5.950GHz
S(2,2)=0.485 / -128.876
impedance = $Z_0 * (0.415 - j0.409)$

APPLICATION CIRCUIT

(Top view)

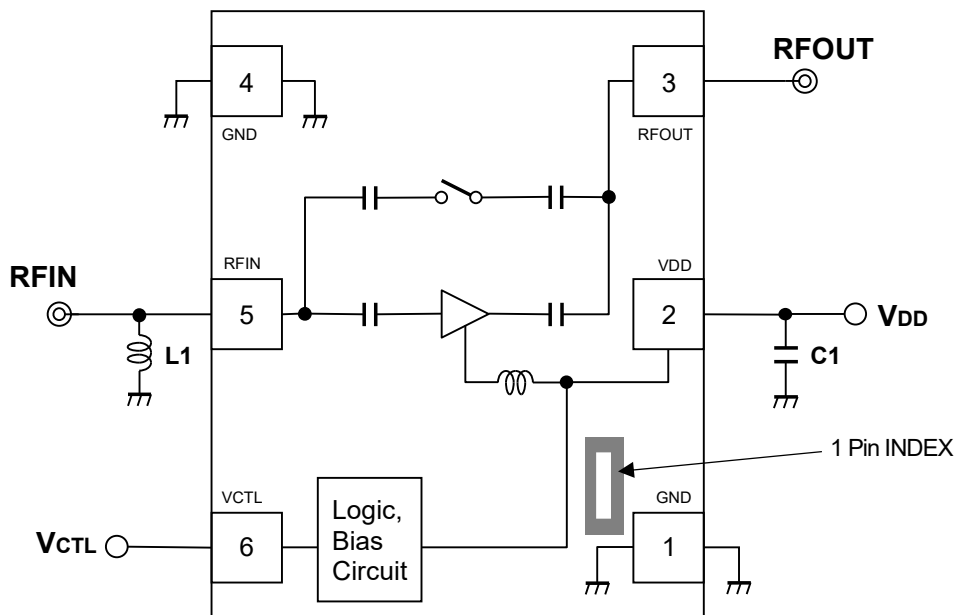

Parts list

Part ID	Value	Notes
L1	1.6nH	LQP03TN_02 series (MURATA)
C1	4700pF	GRM03 series (MURATA)

■ NF MEASUREMENT BLOCK DIAGRAM

Measuring instruments

NF Analyzer : Keysight N8975A
 Noise Source : Keysight 346A

Setting the NF analyzer

Measurement mode form

Device under test : Amplifier

System downconverter : off

Mode setup form

Sideband : LSB

Averages : 16

Average mode : Point

Bandwidth : 4MHz

Loss comp : off

Tcold : setting the temperature of noise source (305.15K)

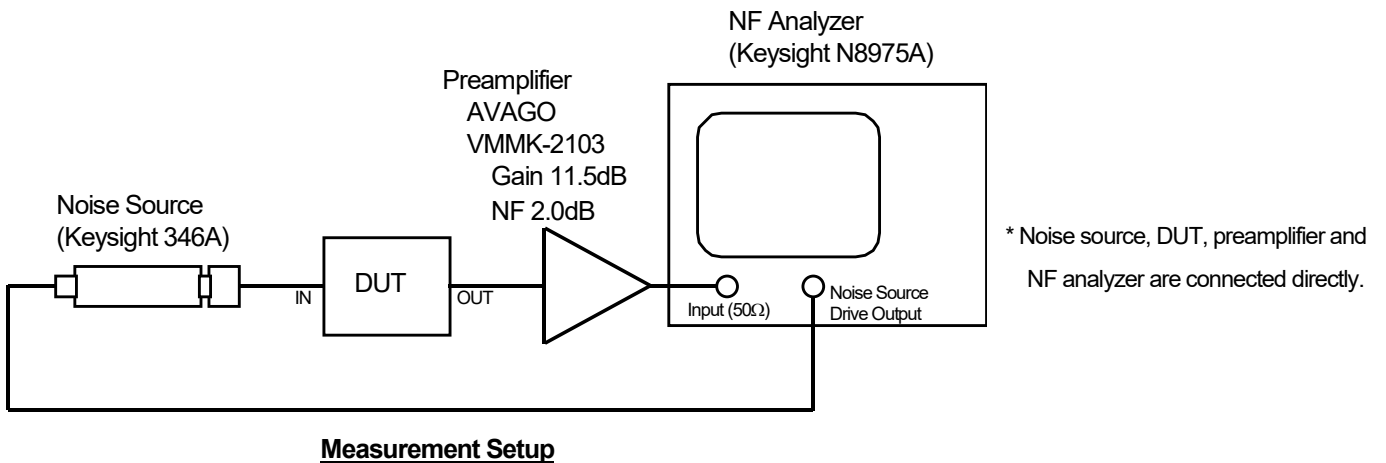
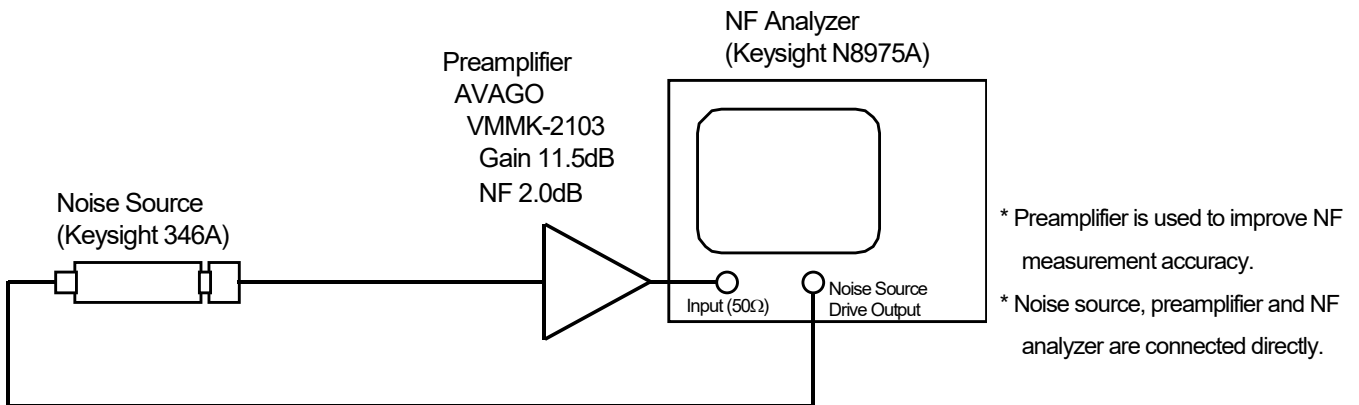

■ EVALUATION BOARD

(Top View)

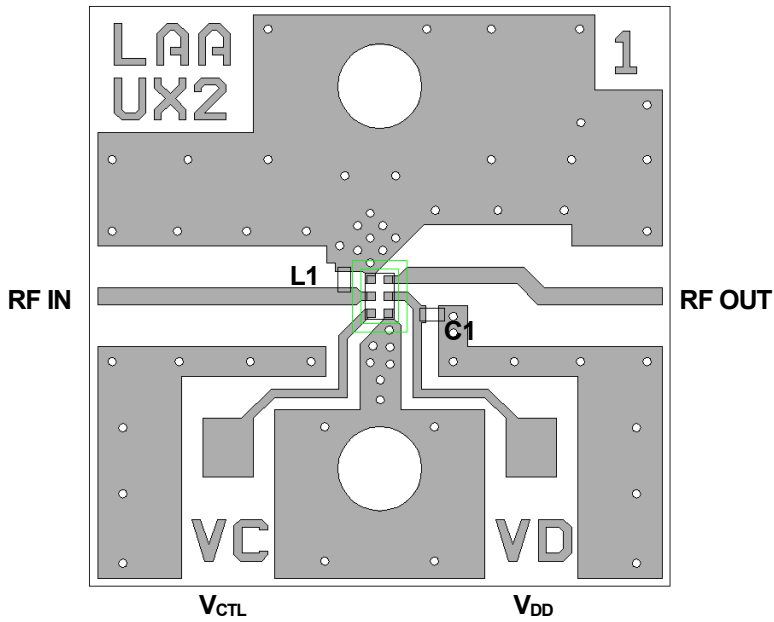

PCB Information

Substrate: FR-4

Thickness: 0.2mm

Microstrip line width: 0.4mm ($Z_0=50\Omega$)

Size: 14.0mm x 14.0mm

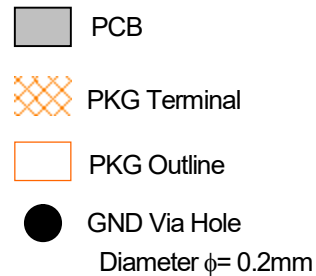
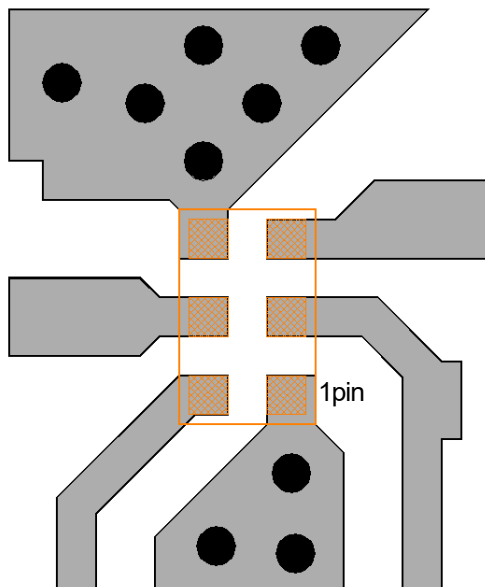

< PCB LAYOUT GUIDELINE >



PRECAUTIONS

- All external parts should be placed as close as possible to the IC.
- For good RF performance, all GND terminals must be connected to PCB ground plane of substrate, and via-holes for GND should be placed near the IC.

RECOMMENDED FOOTPRINT PATTERN (EPFFP6-X2)

-  : Land
-  : Mask (Open area) *Metal mask thickness: 100 μm
-  : Resist (Open area)

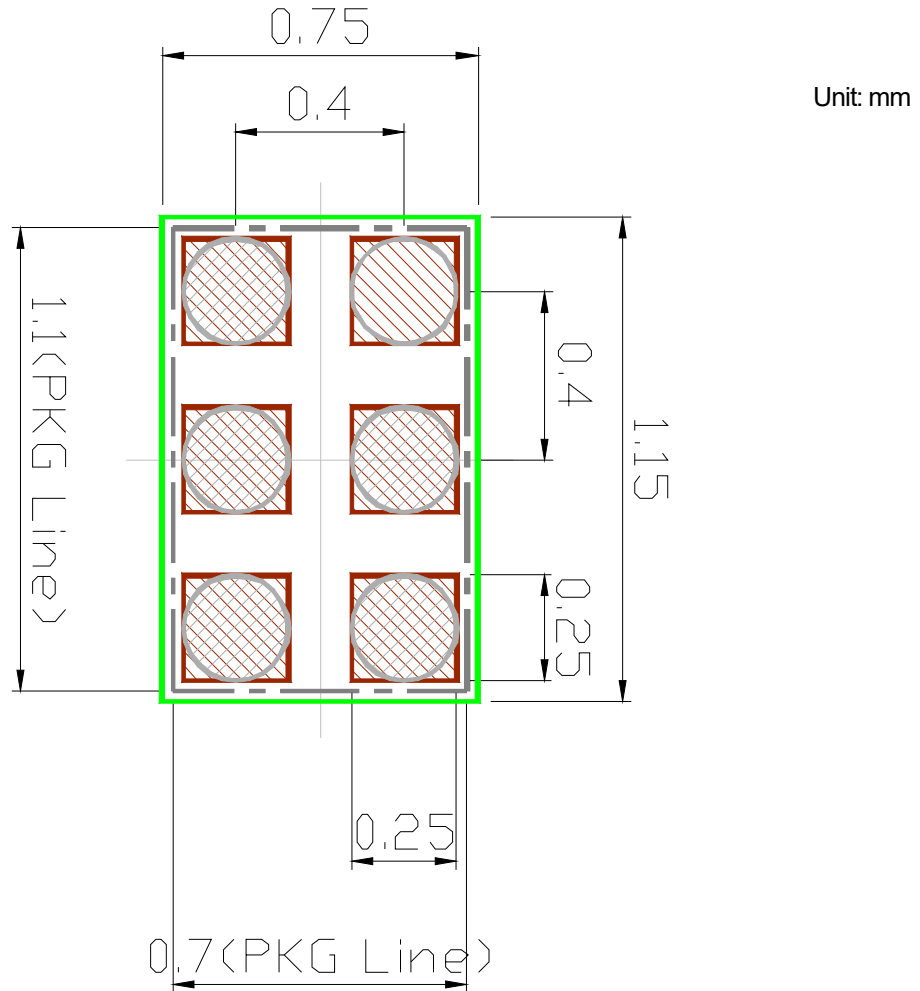

■ PACKAGE OUTLINE (EPFFP6-X2)

TOP VIEW

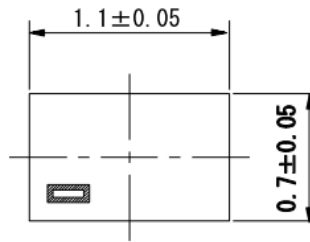

SIDE VIEW

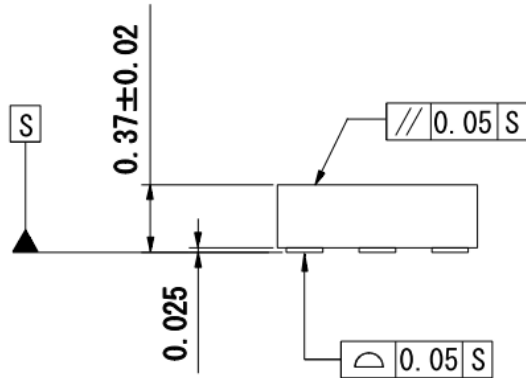

BOTTOM VIEW

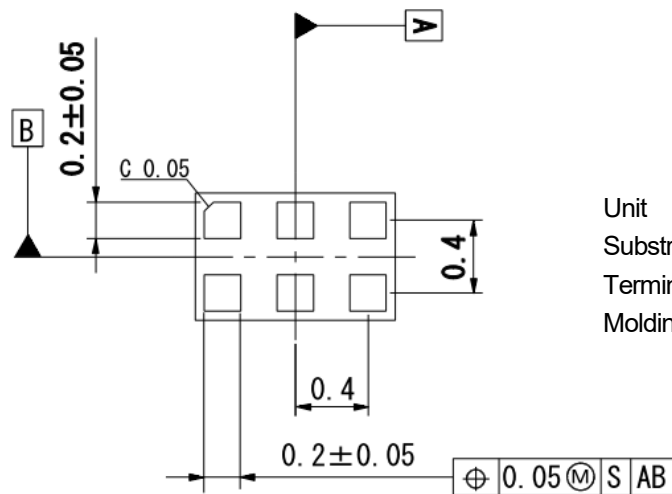

Unit : mm
 Substrate : FR4
 Terminal treat : Ni/Pd/Au
 Molding material : Epoxy resin

PACKING SPECIFICATION (EPFFP6-X2) TAPING DIMENSIONS

Unit: mm

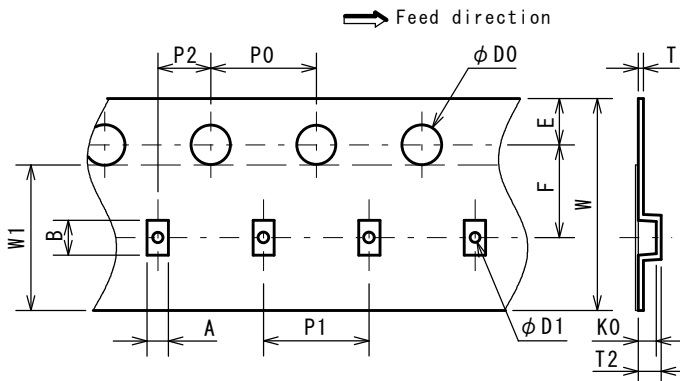

SYMBOL	DIMENSION	REMARKS
A	0.85±0.03	BOTTOM DIMENSION
B	1.25±0.03	BOTTOM DIMENSION
D0	1.5 ^{+0.1} ₀	
D1	0.35±0.05	
E	1.75±0.1	
F	3.5±0.05	
P0	4.0±0.1	
P1	4.0±0.1	
P2	2.0±0.05	
T	0.2±0.05	
T2	0.75	
K0	0.45±0.05	
W	8.0 ^{+0.3} _{-0.1}	
W1	5.5	THICKNESS 0.1max

REEL DIMENSIONS

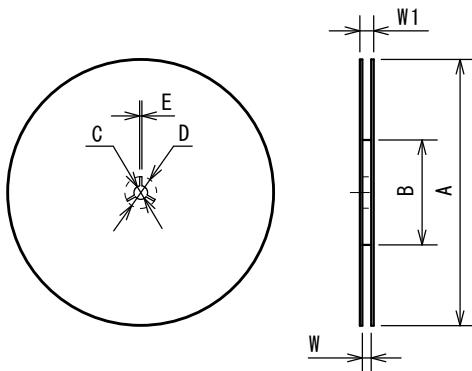

SYMBOL	DIMENSION
A	φ 180 ⁰ _{-1.5}
B	φ 60 ⁺¹ ₀
C	φ 13±0.2
D	φ 21±0.8
E	2±0.5
W	9 ^{+0.3} ₀
W1	11.4±0.1

TAPING STATE

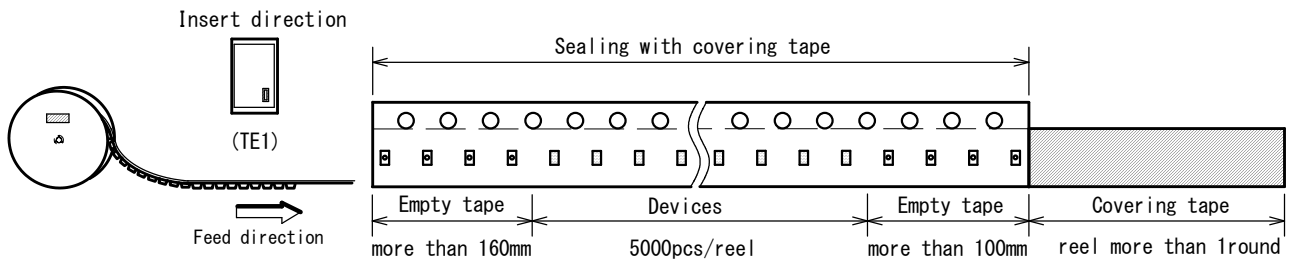

PACKING STATE

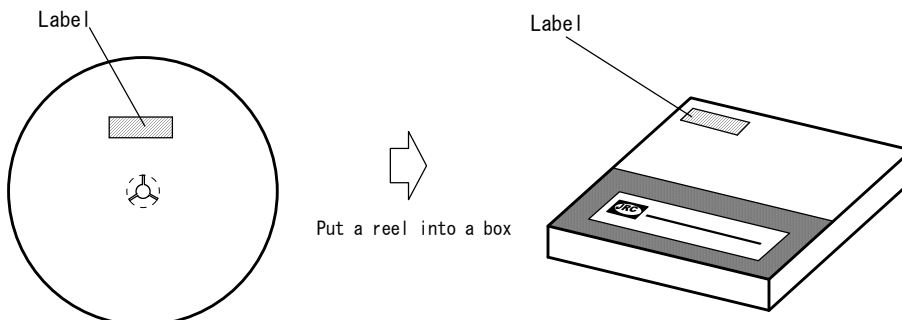

1. The products and the product specifications described in this document are subject to change or discontinuation of production without notice for reasons such as improvement. Therefore, before deciding to use the products, please refer to our sales representatives for the latest information thereon.
2. The materials in this document may not be copied or otherwise reproduced in whole or in part without the prior written consent of us.
3. This product and any technical information relating thereto are subject to complementary export controls (so-called KNOW controls) under the Foreign Exchange and Foreign Trade Law, and related politics ministerial ordinance of the law. (Note that the complementary export controls are inapplicable to any application-specific products, except rockets and pilotless aircraft, that are insusceptible to design or program changes.) Accordingly, when exporting or carrying abroad this product, follow the Foreign Exchange and Foreign Trade Control Law and its related regulations with respect to the complementary export controls.
4. The technical information described in this document shows typical characteristics and example application circuits for the products. The release of such information is not to be construed as a warranty of or a grant of license under our or any third party's intellectual property rights or any other rights.
5. The products listed in this document are intended and designed for use as general electronic components in standard applications (office equipment, telecommunication equipment, measuring instruments, consumer electronic products, amusement equipment etc.). Those customers intending to use a product in an application requiring extreme quality and reliability, for example, in a highly specific application where the failure or misoperation of the product could result in human injury or death should first contact us.
 - Aerospace Equipment
 - Equipment Used in the Deep Sea
 - Power Generator Control Equipment (nuclear, steam, hydraulic, etc.)
 - Life Maintenance Medical Equipment
 - Fire Alarms / Intruder Detectors
 - Vehicle Control Equipment (automotive, airplane, railroad, ship, etc.)
 - Various Safety Devices
 - Traffic control system
 - Combustion equipment

In case your company desires to use this product for any applications other than general electronic equipment mentioned above, make sure to contact our company in advance. Note that the important requirements mentioned in this section are not applicable to cases where operation requirements such as application conditions are confirmed by our company in writing after consultation with your company.

6. We are making our continuous effort to improve the quality and reliability of our products, but semiconductor products are likely to fail with certain probability. In order to prevent any injury to persons or damages to property resulting from such failure, customers should be careful enough to incorporate safety measures in their design, such as redundancy feature, fire containment feature and fail-safe feature. We do not assume any liability or responsibility for any loss or damage arising from misuse or inappropriate use of the products.
7. The products have been designed and tested to function within controlled environmental conditions. Do not use products under conditions that deviate from methods or applications specified in this datasheet. Failure to employ the products in the proper applications can lead to deterioration, destruction or failure of the products. We shall not be responsible for any bodily injury, fires or accident, property damage or any consequential damages resulting from misuse or misapplication of the products.
8. **Quality Warranty**
 - 8-1. **Quality Warranty Period**

In the case of a product purchased through an authorized distributor or directly from us, the warranty period for this product shall be one (1) year after delivery to your company. For defective products that occurred during this period, we will take the quality warranty measures described in section 8-2. However, if there is an agreement on the warranty period in the basic transaction agreement, quality assurance agreement, delivery specifications, etc., it shall be followed.
 - 8-2. **Quality Warranty Remedies**

When it has been proved defective due to manufacturing factors as a result of defect analysis by us, we will either deliver a substitute for the defective product or refund the purchase price of the defective product.

Note that such delivery or refund is sole and exclusive remedies to your company for the defective product.
 - 8-3. **Remedies after Quality Warranty Period**

With respect to any defect of this product found after the quality warranty period, the defect will be analyzed by us. On the basis of the defect analysis results, the scope and amounts of damage shall be determined by mutual agreement of both parties. Then we will deal with upper limit in Section 8-2. This provision is not intended to limit any legal rights of your company.
9. Anti-radiation design is not implemented in the products described in this document.
10. The X-ray exposure can influence functions and characteristics of the products. Confirm the product functions and characteristics in the evaluation stage.
11. WLCSP products should be used in light shielded environments. The light exposure can influence functions and characteristics of the products under operation or storage.
12. Warning for handling Gallium and Arsenic (GaAs) products (Applying to GaAs MMIC, Photo Reflector). These products use Gallium (Ga) and Arsenic (As) which are specified as poisonous chemicals by law. For the prevention of a hazard, do not burn, destroy, or process chemically to make them as gas or power. When the product is disposed of, please follow the related regulation and do not mix this with general industrial waste or household waste.
13. Please contact our sales representatives should you have any questions or comments concerning the products or the technical information.



Nisshinbo Micro Devices Inc.

Official website

<https://www.nisshinbo-microdevices.co.jp/en/>

Purchase information

<https://www.nisshinbo-microdevices.co.jp/en/buy/>

Looking for pricing, stock, or lifecycle information?

Click below to explore more details on WIN SOURCE:

-  [View NJG1182UX2-TE1 on WIN SOURCE](#)
-  [Nisshinbo Micro Devices Inc. Information](#)

Optimize Your Supply Chain with WIN SOURCE Solutions

-  Global Sourcing Solution
-  Obsolete Management
-  Cost Control Management
-  Shortage Management
-  Alternative Solution
-  Excess Inventory Management