



TGA2624-SM

9–10 GHz 20 W GaN Power Amplifier

General Description

Qorvo's TGA2624-SM is a packaged, high power X-Band amplifier fabricated on Qorvo's production 0.25 μm GaN on SiC process. Operating from 9-10 GHz, the TGA2624-SM typically generates 20 W of saturated output power with a power-added efficiency greater than 40% and 25 dB of large signal gain.

The TGA2624-SM is packaged in a 7 x 7 mm air-cavity, laminate based QFN. Both RF ports are internally DC blocked and matched to 50 ohms enabling simple system integration. Ideally suited for pulsed applications, the TGA2624-SM offers excellent power, PAE and gain performance that can save costs on existing platforms while enabling the development of future systems.

Lead-free and RoHS compliant.

Evaluation boards are available upon request.

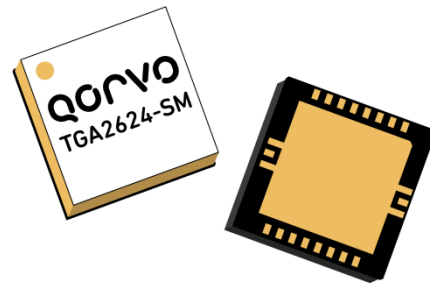

Product Features

- Frequency Range: 9–10 GHz
- P_{SAT} : 43 dBm @ $P_{IN} = 18$ dBm
- PAE: >40% @ $P_{IN} = 18$ dBm
- Power Gain: 25 dB @ $P_{IN} = 18$ dBm
- Bias: $V_D = 28$ V, $I_{DQ} = 365$ mA (Pulsed V_D : PW = 100 μs and DC = 10 %)
- Package Dimensions: 7 x 7 x 1.75 mm

Functional Block Diagram

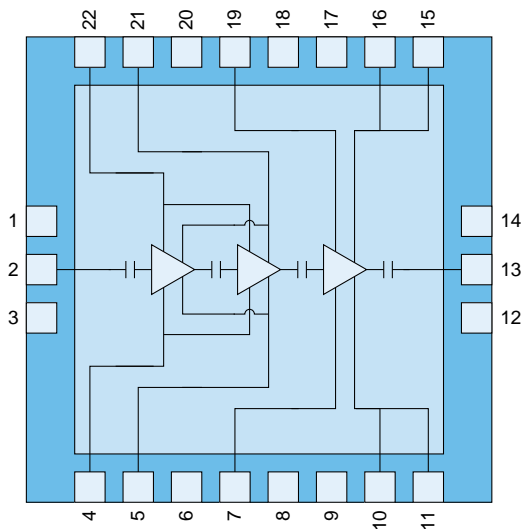

Applications

- Weather and Marine Radar

Ordering Information

Part	Description
TGA2624-SM	9–10 GHz 20 W GaN Power Amplifier
TGA2624-SM EVB	Evaluation Board

Absolute Maximum Ratings

Parameter	Value/Range
Drain Voltage (V_D)	40 V
Gate Voltage Range (V_G)	-8 to 0 V
Drain Current (I_D)	3.8 A
Gate Current (I_G)	See plot page 3
Power Dissipation (P_{DISS}), 85 °C, CW	44 W
Input Power (P_{IN}), CW, 50 Ω , $V_D = 28$ V, 85 °C	25 dBm
Input Power (P_{IN}), CW, VSWR 6:1, $V_D = 28$ V, 85 °C	19 dBm
Mounting Temperature (30 seconds)	260 °C
Storage Temperature	-55 to 150 °C

Operation of this device outside the parameter ranges given above may cause permanent damage. These are stress ratings only, and functional operation of the device at these conditions is not implied.

Recommended Operating Conditions

Parameter	Value/Range
Drain Voltage (V_D): Pulsed	28 V
Drain Current (I_{DQ})	365 mA
Gate Voltage Range (V_G)	-2.8 to -2.0 V
Temperature (T_{BASE})	-40 to 85 °C

Electrical specifications are measured at specified test conditions. Specifications are not guaranteed over all recommended operating conditions.

Electrical Specifications

Test conditions unless otherwise noted: 25 °C, $V_D = 28$ V, $I_{DQ} = 365$ mA, Pulsed V_D : PW = 100 us, DC = 10 %

Parameter	Min	Typical	Max	Units
Operational Frequency Range	9		10	GHz
Small Signal Gain		>34		dB
Input Return Loss		>9		dB
Output Return Loss		>8.5		dB
Output Power ($P_{IN} = 18$ dBm)	42	43		dBm
Power Added Efficiency ($P_{IN} = 18$ dBm)	30	>40		%
Power Gain ($P_{IN} = 18$ dBm)		25		dB
Output Power Temperature Coefficient From 25 °C to 85 °C ($P_{IN} = 18$ dBm)		-0.02		dBm/°C
Recommended Operating Voltage:	20	28	32	V
Gate Leakage ($V_D = 10$ V, $V_G = -3.7$ V)	-8.3			mA

Typical Performance: Large Signal (Pulsed Operation)

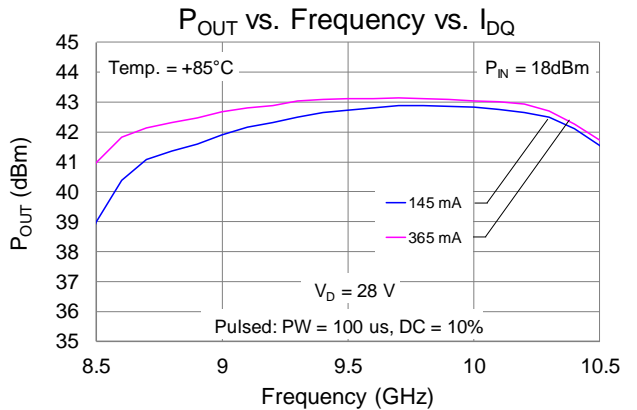
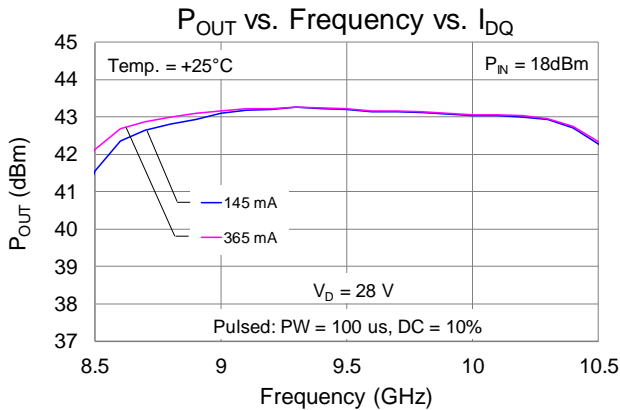
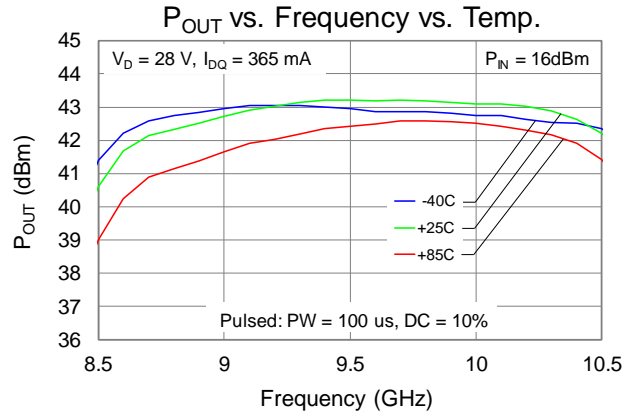
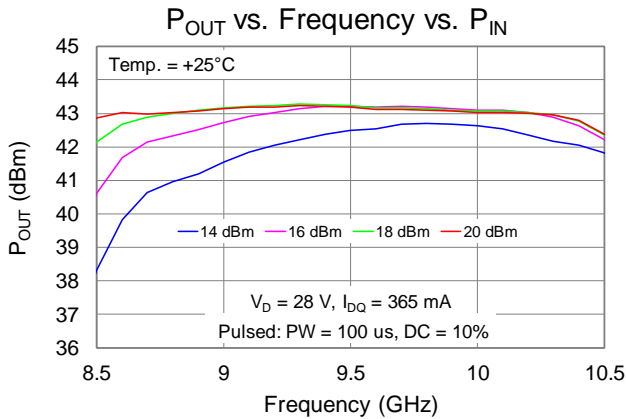
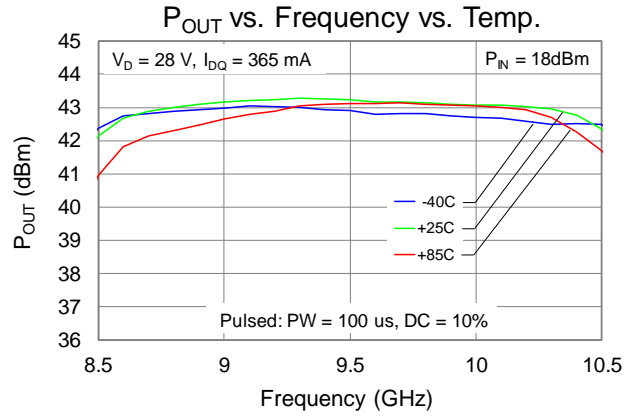
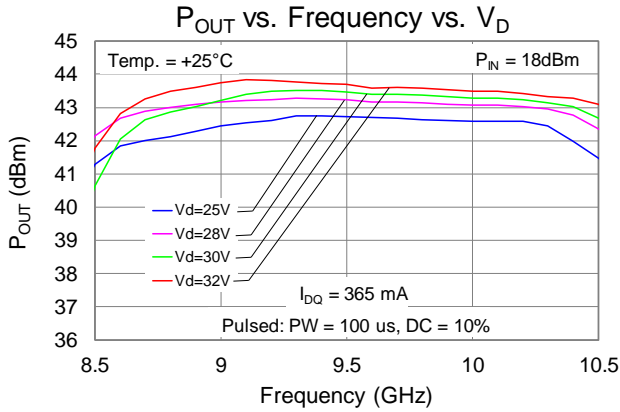

Typical Performance: Large Signal (Pulsed Operation)

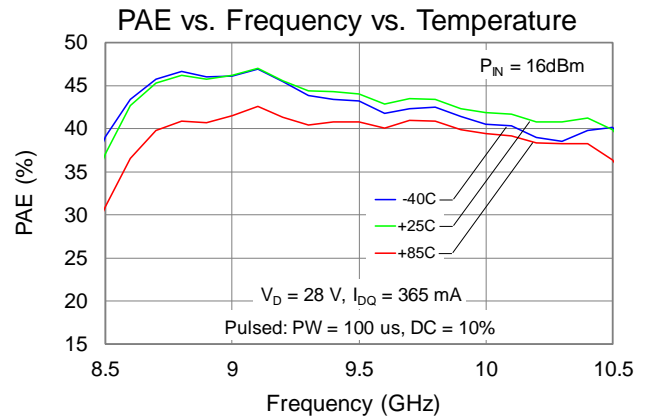
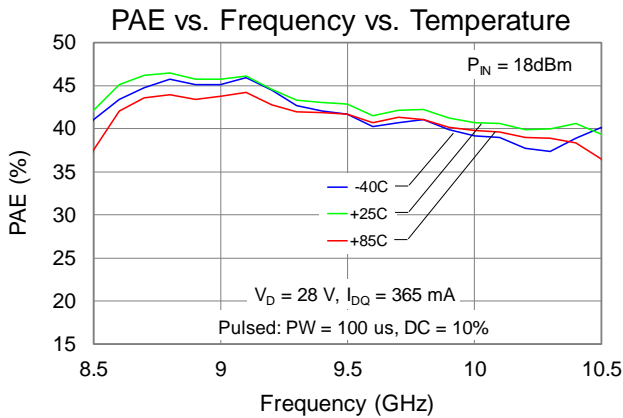
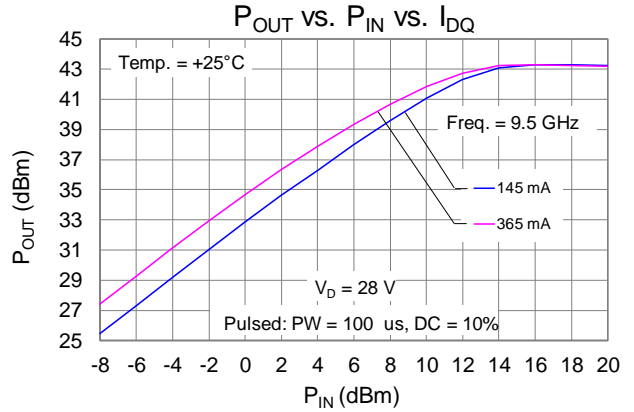
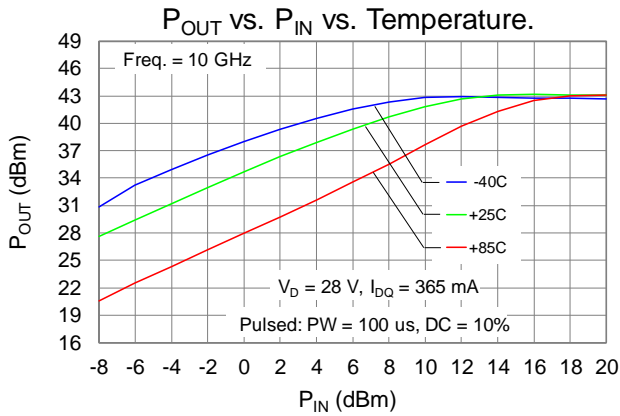
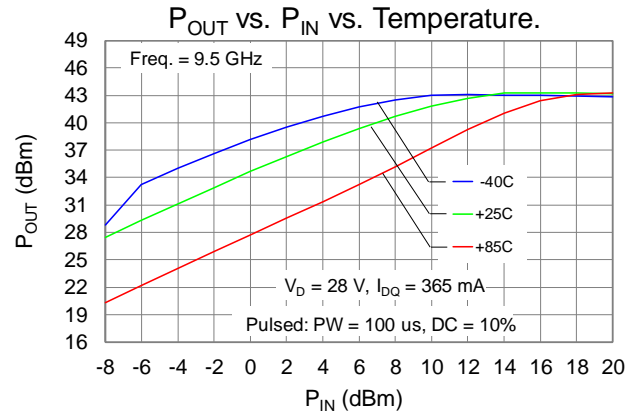

Typical Performance: Large Signal (Pulsed Operation)

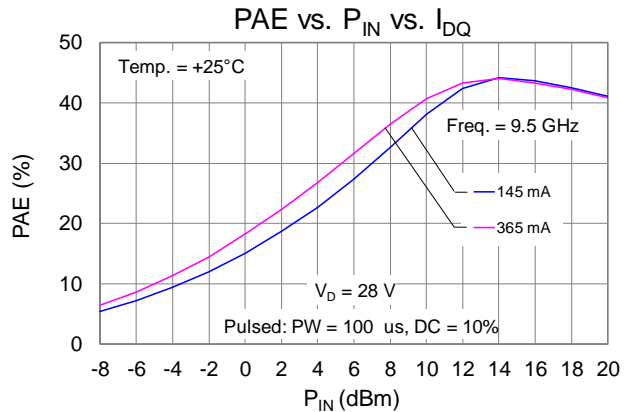
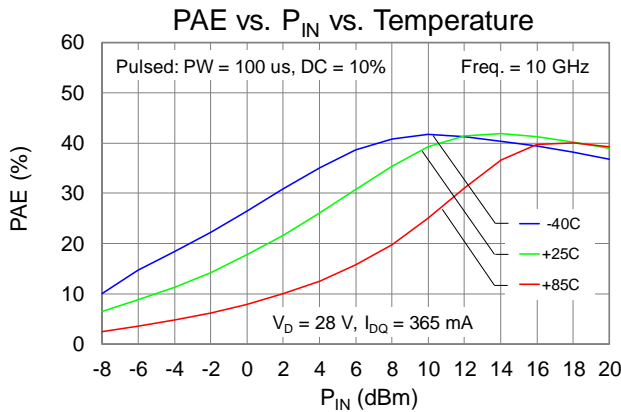
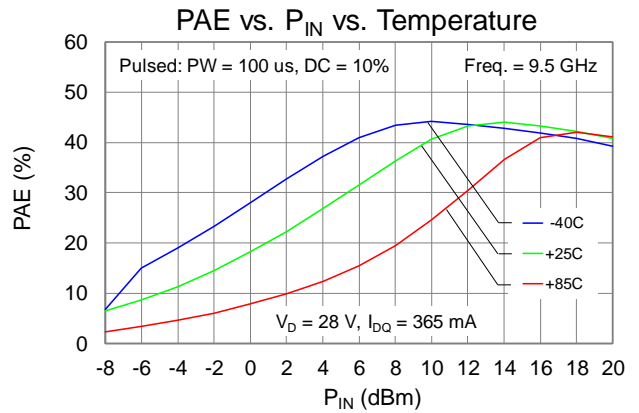
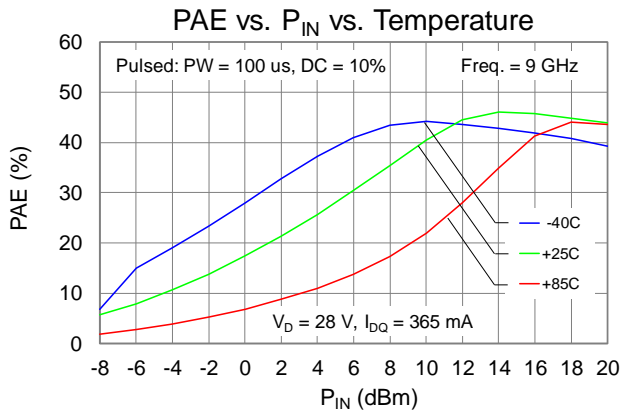
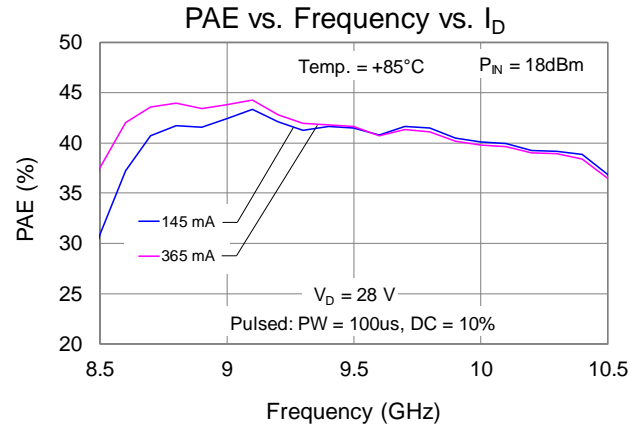
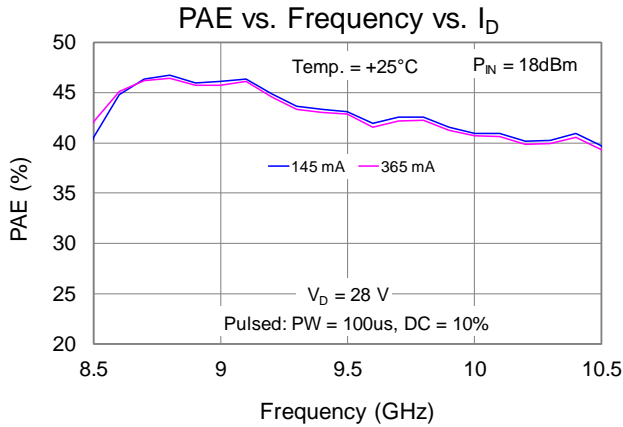

Typical Performance: Large Signal (Pulsed Operation)

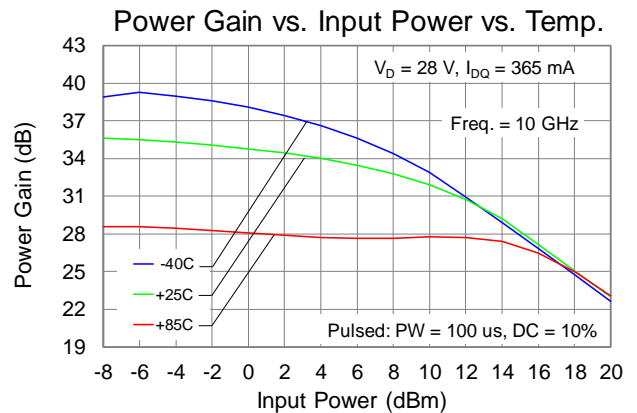
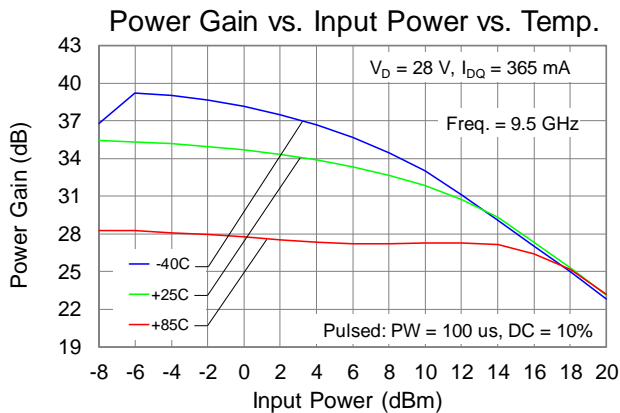
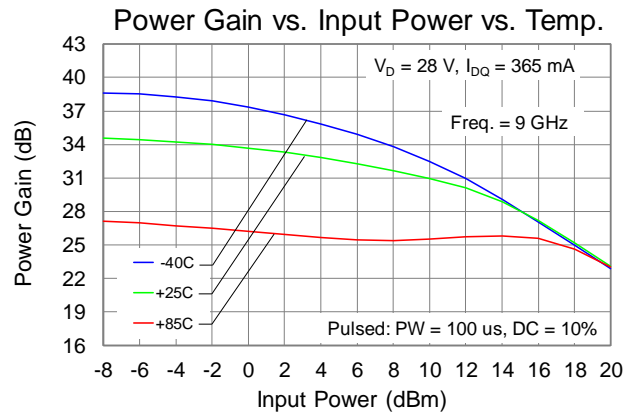
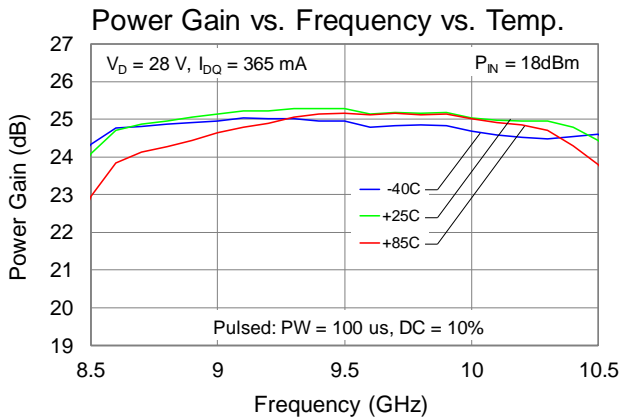
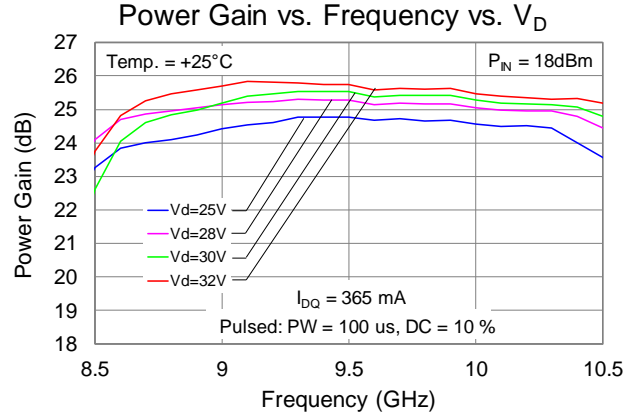
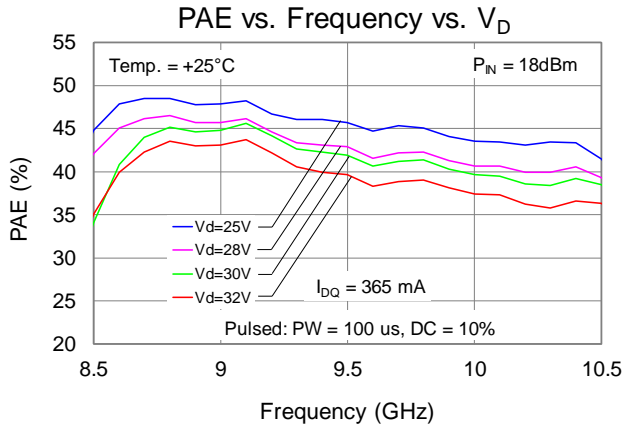

Typical Performance: Large Signal (Pulsed Operation)

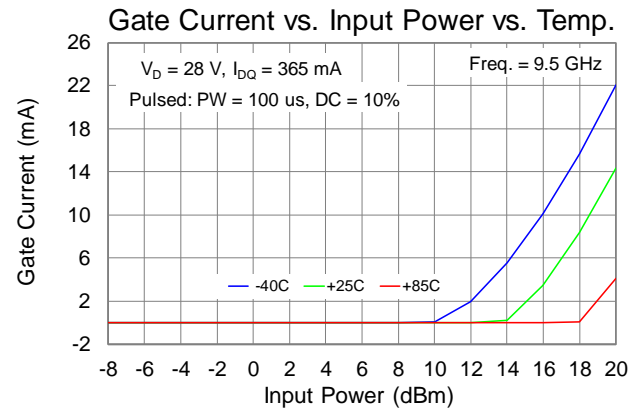
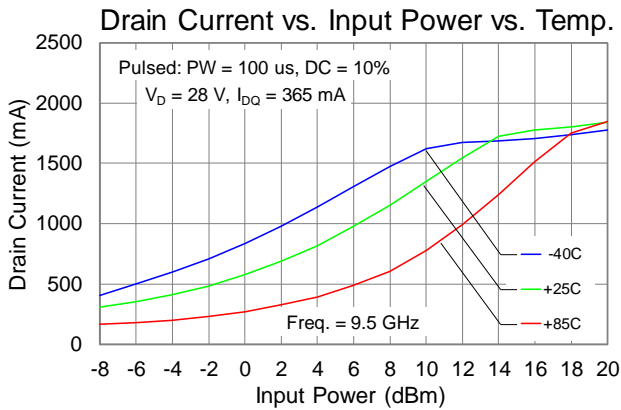
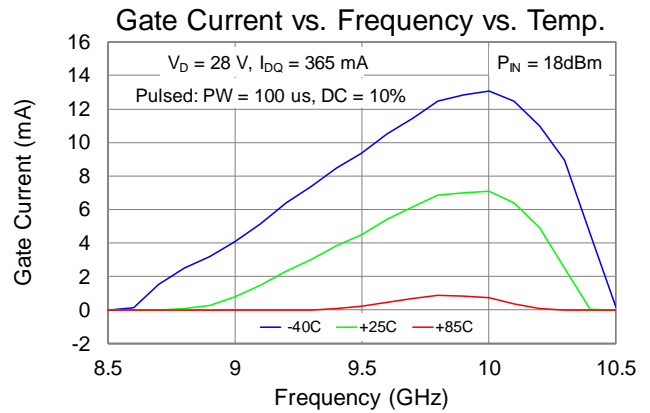
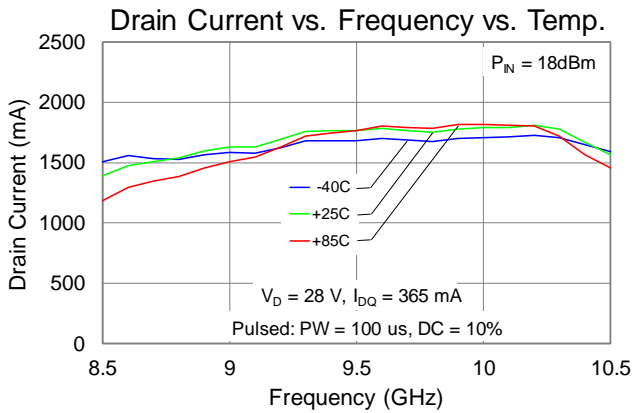
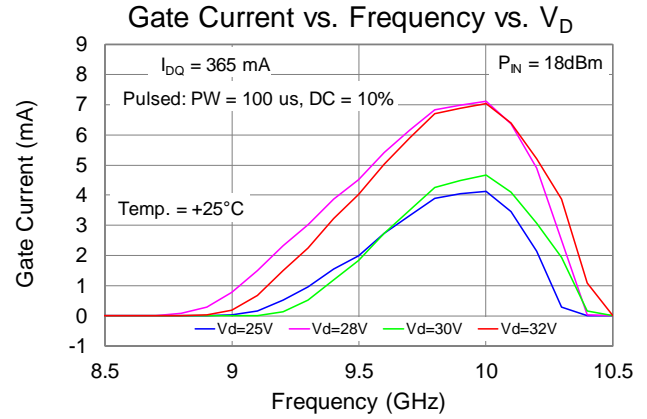
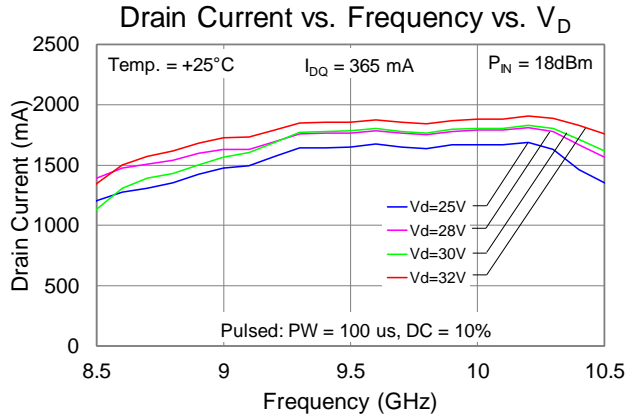

Typical Performance: Linearity (CW Operation)

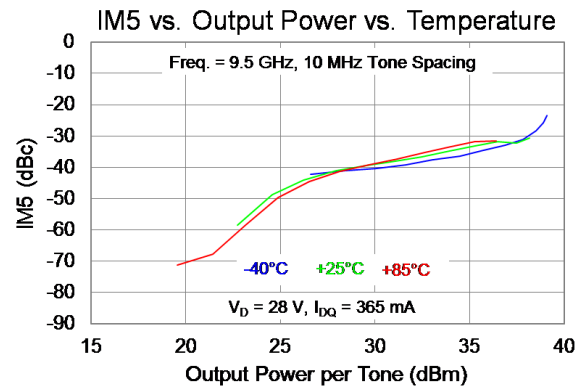
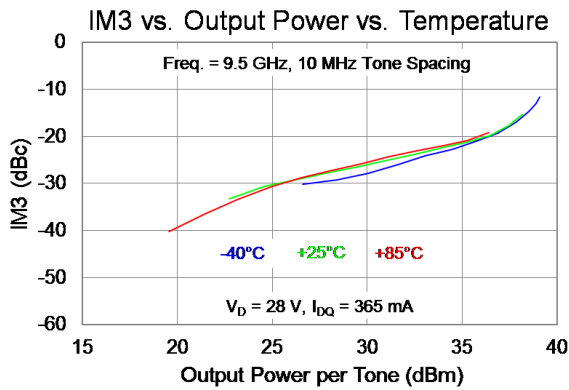
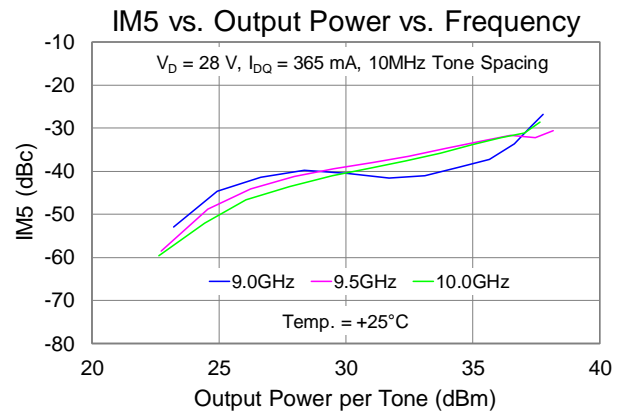
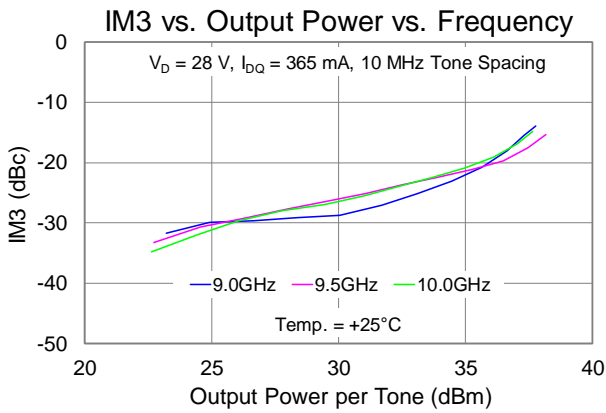
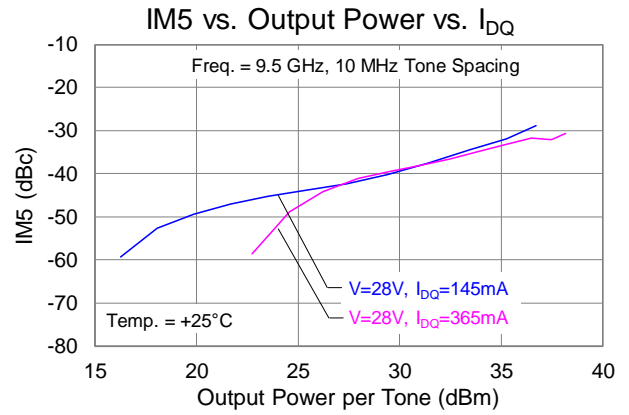
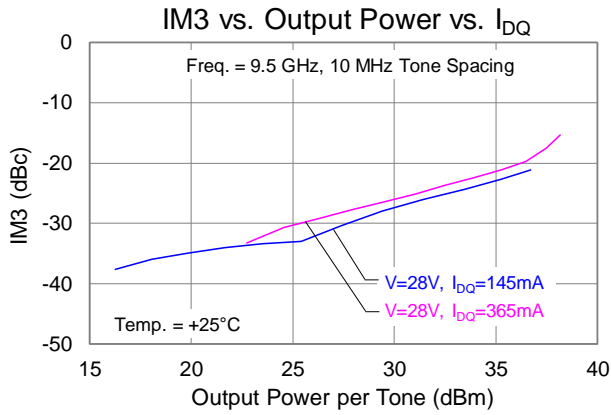

Typical Performance: Linearity (CW Operation)

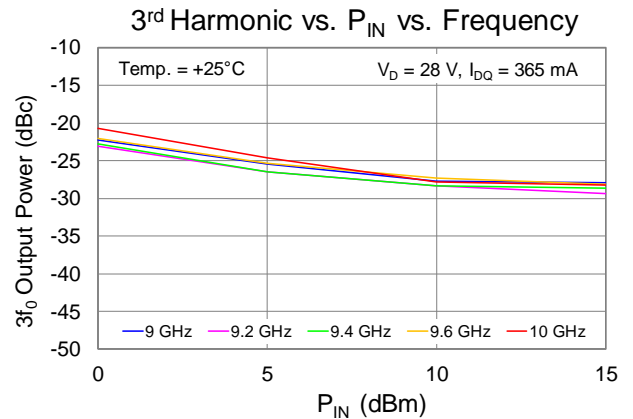
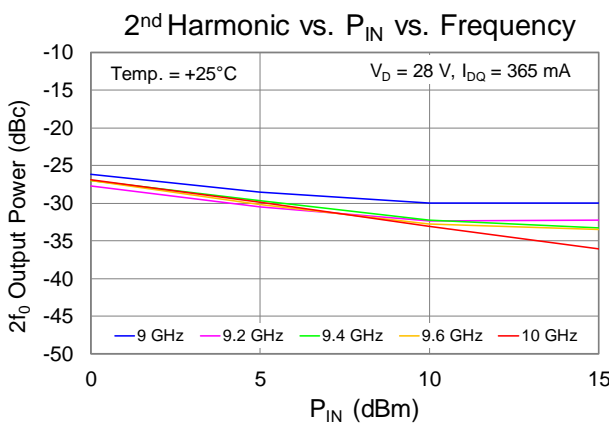
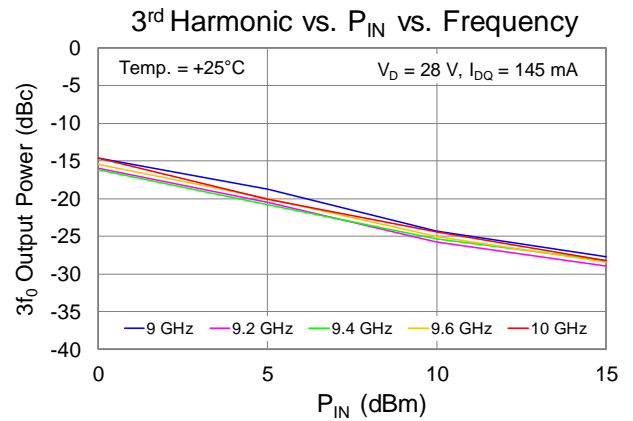
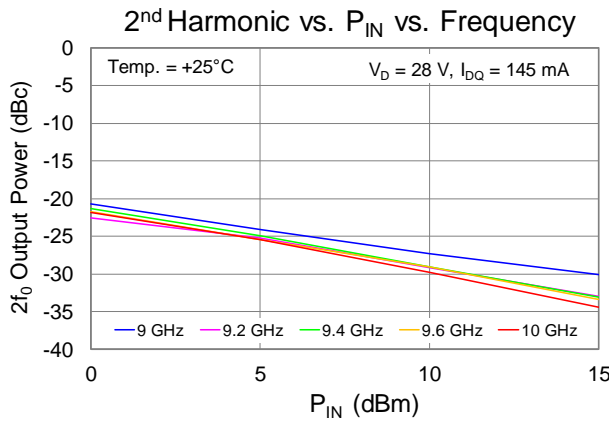
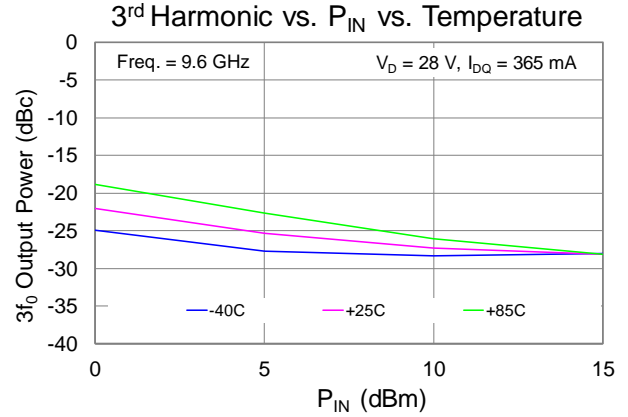
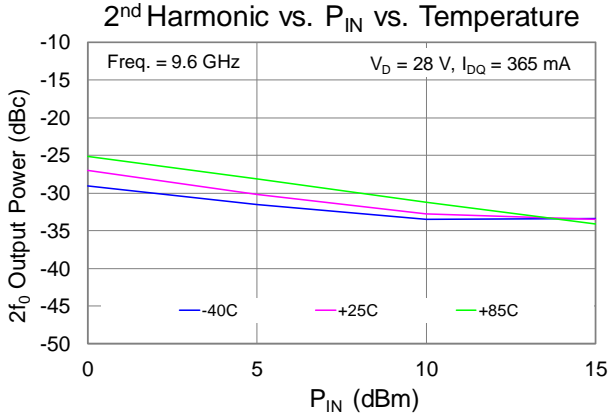

Typical Performance: Small Signal (CW Operation)

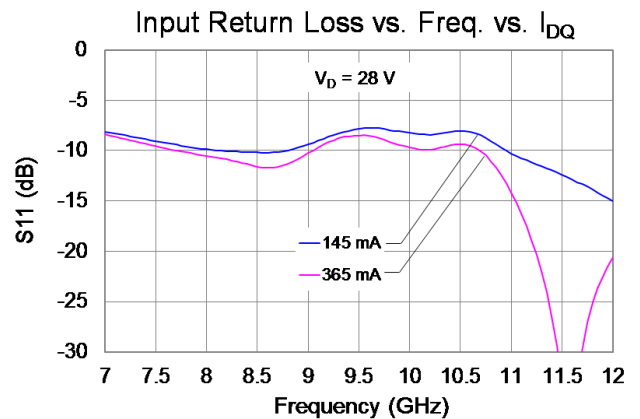
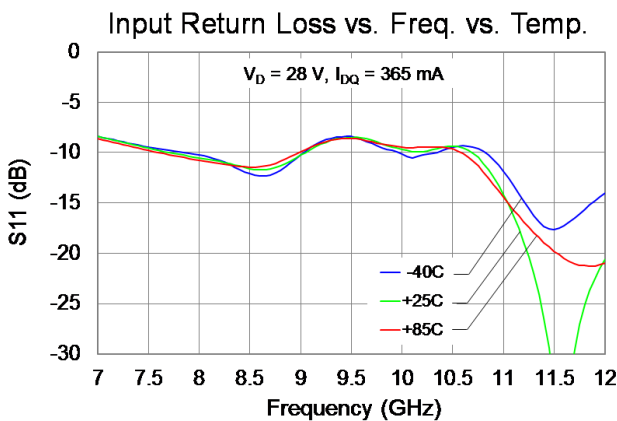
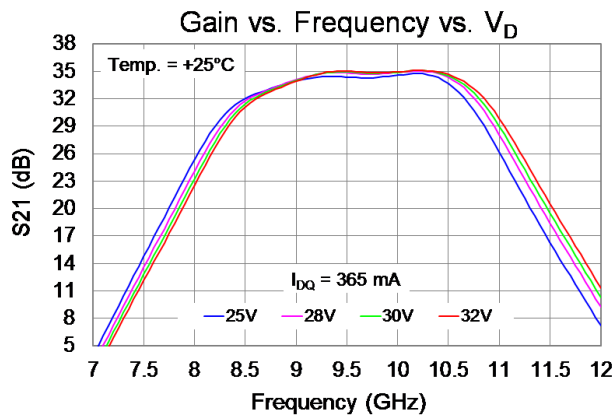
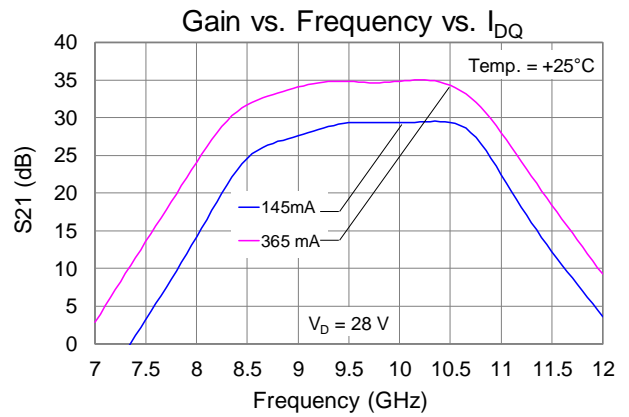
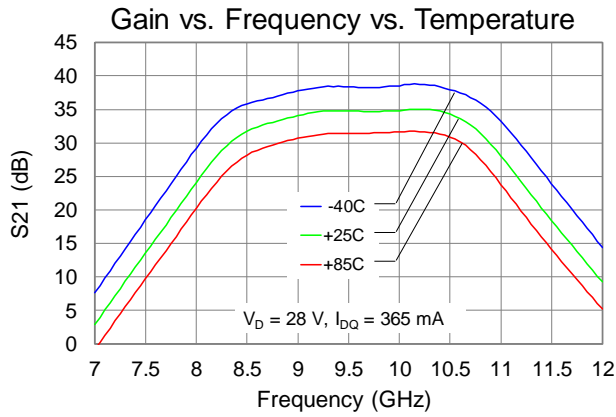

Typical Performance: Small Signal (CW Operation)

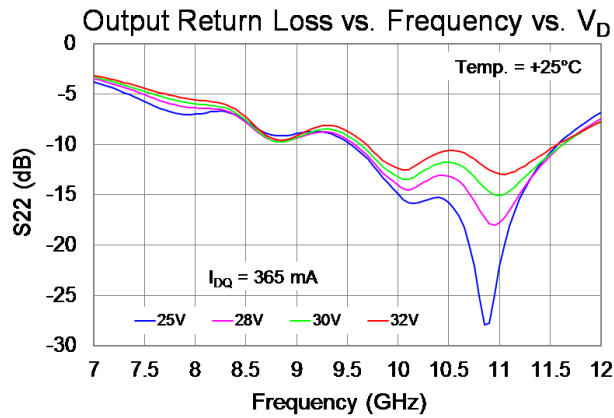
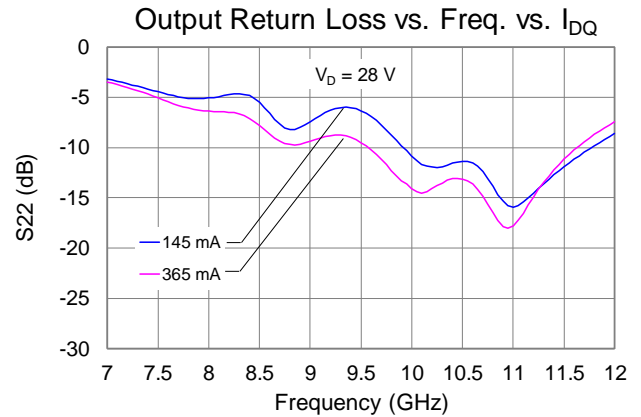
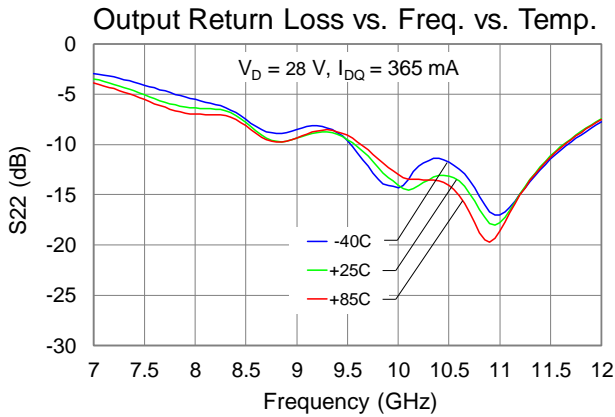
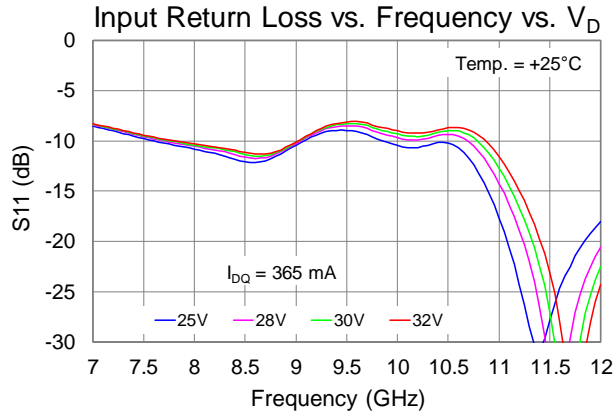

Thermal and Reliability Information

Parameter	Test Conditions	Value	Units
Thermal Resistance (θ_{JC}) ¹	T _{BASE} = 85 °C; V _D = 28 V, I _{DQ} = 365 mA, (Pulsed V _D : PW = 100 us, DC = 10 %), P _{DISS} = 10.22 W	1.31	°C/W
Channel Temperature (T _{CH}) (No RF drive) ²		98.4	°C
Thermal Resistance (θ_{JC}) ¹	T _{BASE} = 85 °C; V _D = 28 V, I _{DQ} = 365 mA, (Pulsed V _D : PW = 100 us, DC = 10 %), I _{D_Drive} = 1.8 A, P _{IN} = 18 dBm, P _{OUT} = 43 dBm, P _{DISS} = 30 W	1.59	°C/W
Channel Temperature (T _{CH}) (Under RF drive) ²		132.8	°C

Notes:

1. Thermal Resistance measured to back of package.
2. IR scan equivalent. Refer to the following document: [GaN Device Channel Temperature, Thermal Resistance, and Reliability Estimates](#)

Power Dissipation and Maximum Gate Current

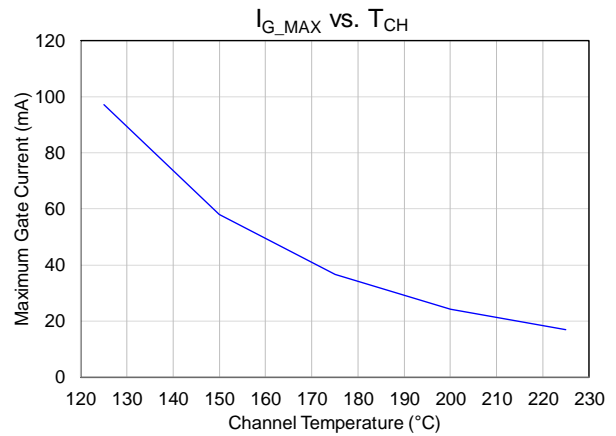
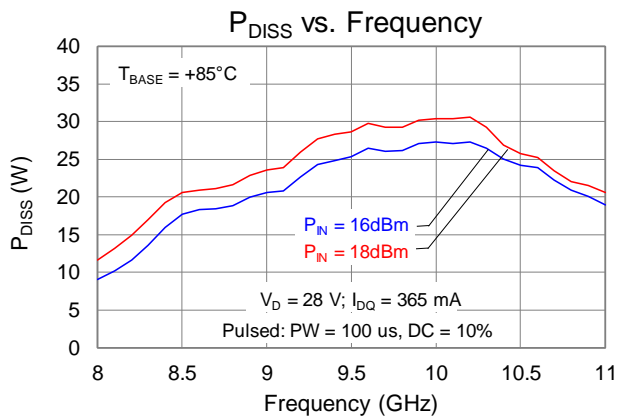

Application Information

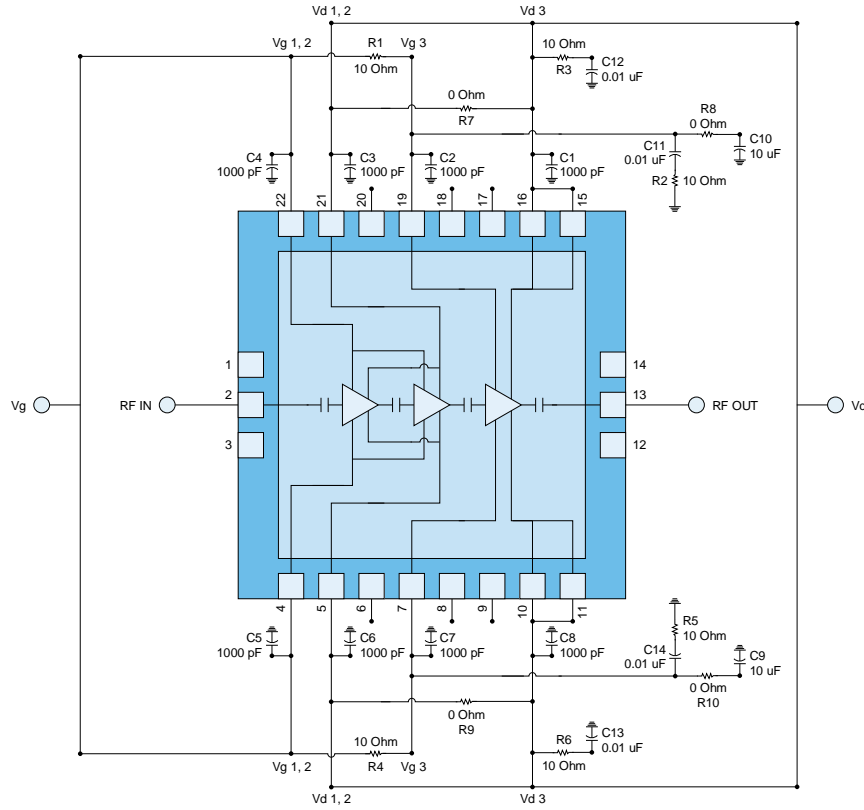

Notes:

1. V_G : must be biased from both sides - $V_{G1,2}$ & V_{G3} can be tied together.
2. V_D : must be biased from both sides - $V_{D1,2}$ & V_{D3} can be tied together.

Bias-up Procedure

- Set I_D limit to 2 A, I_G limit to 25 mA
- Apply -5.0 V to V_G (for pinch-off)
- Increase V_D to +28 V; Ensure I_{DQ} is approx. 0 mA
- Adjust V_G more positive until $I_{DQ} = 365$ mA $V_G \sim -2.5$ V typ
- Apply RF signal

Bias-down Procedure

- Turn off RF signal
- Reduce V_G to -5 V; ensure I_{DQ} is approx. 0 mA
- Set V_D to 0 V
- Turn off V_D supply
- Turn off V_G supply

Pin Layout

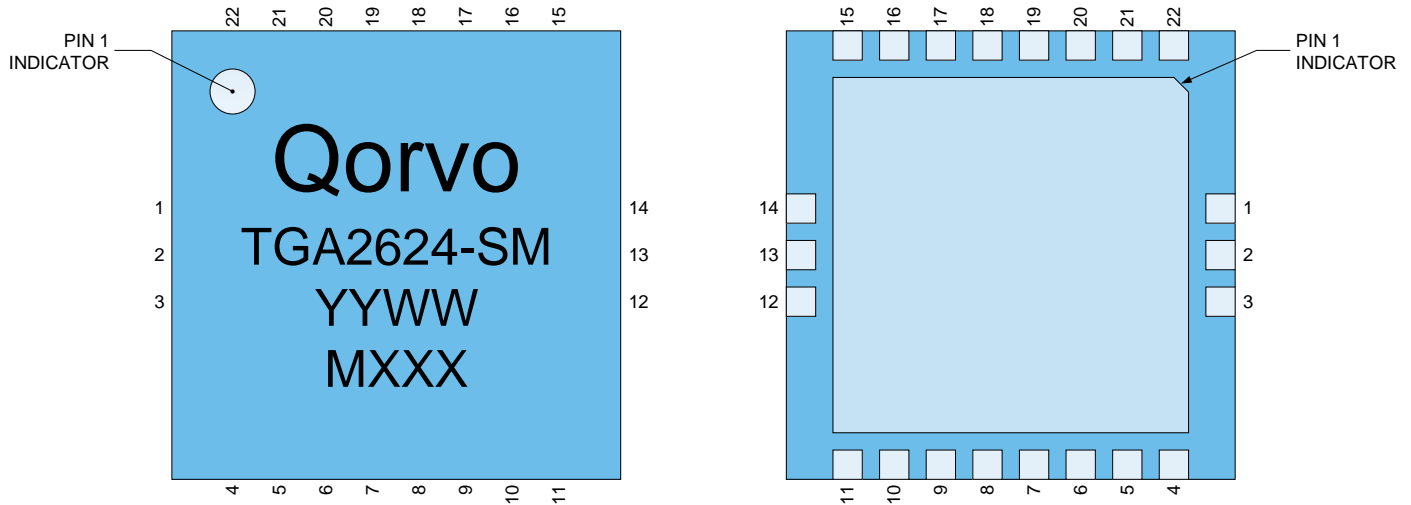

Pin Description

Pin No.	Symbol	Description
1, 3, 12, 14	GND	Must be grounded on the PCB
2	RF _{IN}	Input; matched to 50 Ω; DC blocked
4, 22	V _{G1,2}	Gate Voltages 1,2; Bias network is required; must be biased from both sides; see recommended Application Information on page 13.
5, 21	V _{D1,2}	Drain voltages 1,2; Bias network is required; must be biased from both sides; see recommended Application Information on page 13.
6, 8, 9, 17, 18, 20	N/C	No internal connection
7, 19	V _{G3}	Gate Voltage 3; Bias network is required; must be biased from both sides; see recommended Application Information on page 13.
10, 11, 15, 16	V _{D3}	Drain voltage 3; Bias network is required; must be biased from both sides; see recommended Application Information on page 13.
13	RF _{OUT}	Output; matched to 50 Ω; DC blocked

Evaluation Board Layout

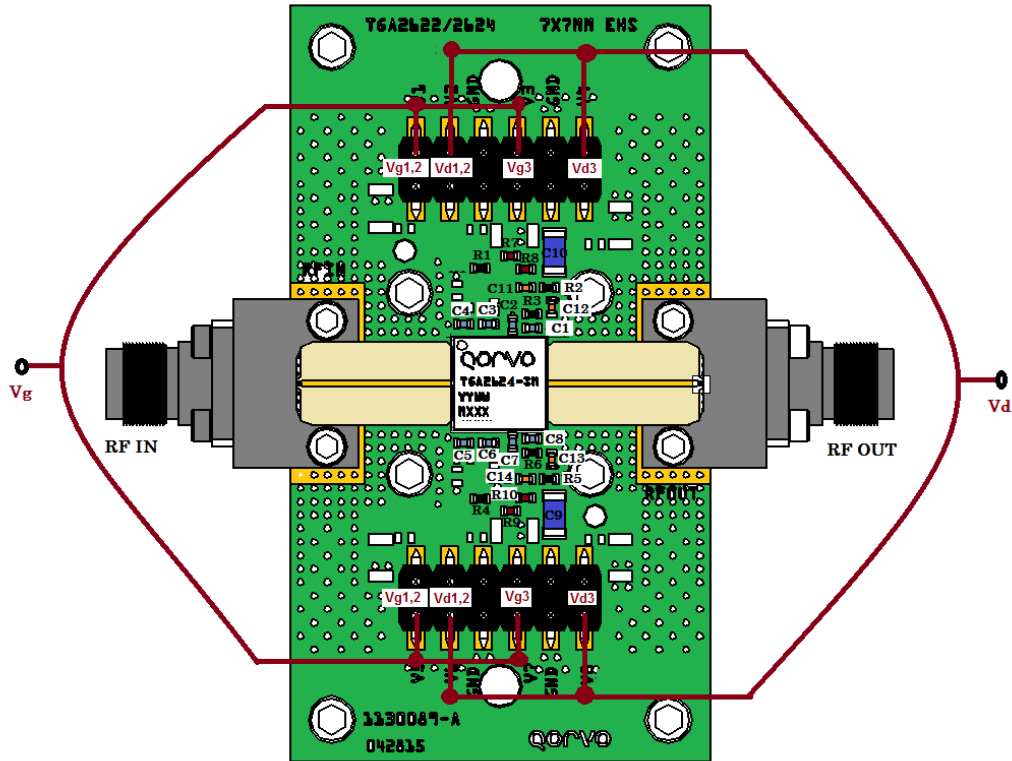

Notes:

- Both Top and Bottom V_D and V_G must be biased

Bill of Material

Reference Design	Value	Description	Manufacture	Part-Number
C1–C8	1000 pF	Cap, 0402, 100 V, 10%, X7R	Various	
C9–C10	10 μ F	Cap, 1206, 50 V, 20%, X5R	Various	
C11–C14	0.01 μ F	Cap, 0402, 50 V, 10%, X7R	Various	
R1–R6	10 ohms	Res, 0402, 50 V, 5%, SMD	Various	
R7–R10	0 ohms	Res, 0402, jumpers required for the above EVB	Various	

Mechanical Information

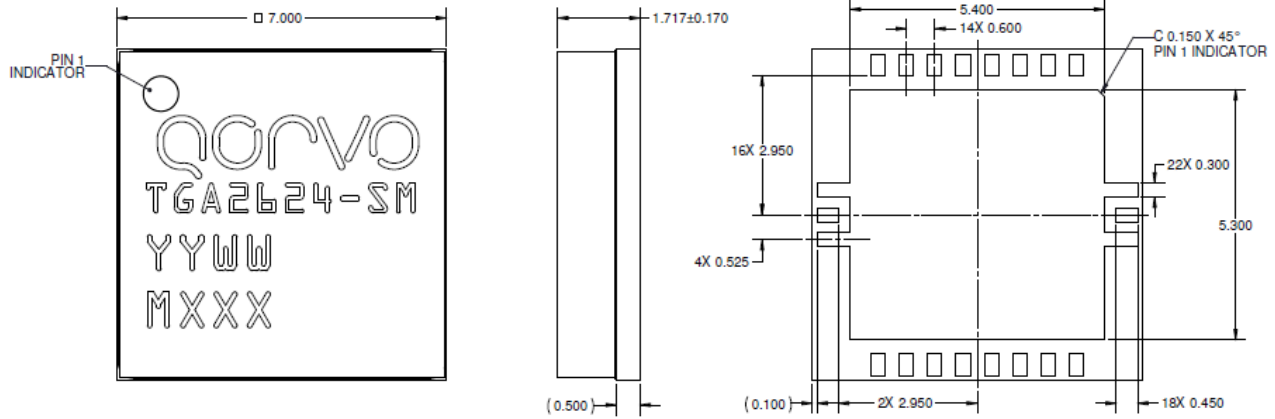

Units: Millimeters (mm)
 Tolerances: unless specified
 x.xx = ± 0.25; x.xxx = ± 0.100
 Materials:
 Base: Laminate Substrate
 Lid: Laminate
 All metalized features are gold plated
 Part is epoxy sealed
 Marking:
 TGA2624-SM: Part number
 YY: Part Assembly year
 WW: Part Assembly week
 MXXX: Batch ID

Assembly Notes

Compatible with lead-free soldering processes with 260°C peak reflow temperature.

This package is air-cavity and non-hermetic, and therefore cannot be subjected to aqueous washing. The use of no-clean solder to avoid washing after soldering is highly recommended.

Contact plating: Ni-Au.

Solder rework not recommended.

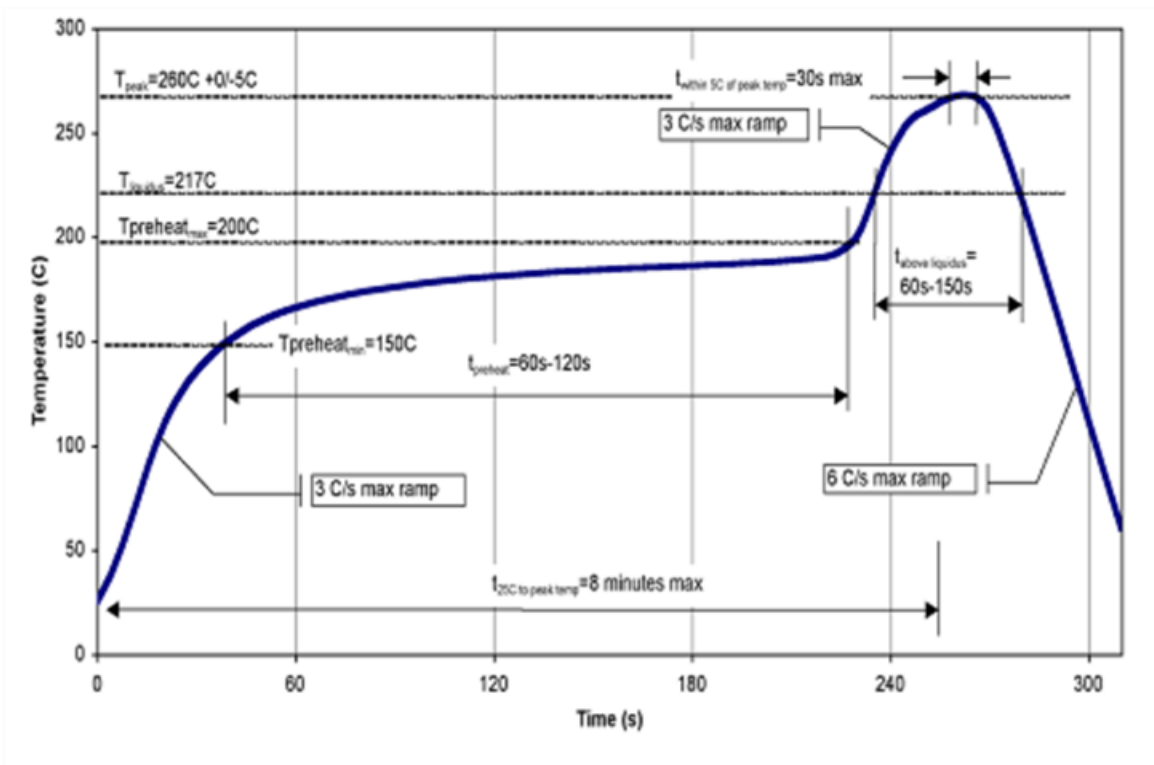

Recommended Soldering Temperature Profile

Handling Precautions

Parameter	Rating	Standard
ESD-Human Body Model (HBM)	1A	JEDEC/JESD22-A114
MSL-Moisture Sensitivity Level	MSL3	JEDEC/IPC/JEDEC J-STD-020



Caution!
 ESD-Sensitive Device

RoHS Compliance

This part is compliant with 2011/65/EU RoHS directive (Restrictions on the Use of Certain Hazardous Substances in Electrical and Electronic Equipment) as amended by Directive 2015/863/EU.

This product also has the following attributes:

- Lead Free
- Antimony Free
- TBBP-A (C₁₅H₁₂Br₄O₂) Free
- PFOS Free

Contact Information

For the latest specifications, additional product information, worldwide sales and distribution locations.

Web: www.qorvo.com

Tel: 1-844-890-8163

Email: customer.support@qorvo.com

Important Notice

The information contained herein is believed to be reliable; however, Qorvo makes no warranties regarding the information contained herein and assumes no responsibility or liability whatsoever for the use of the information contained herein. All information contained herein is subject to change without notice. Customers should obtain and verify the latest relevant information before placing orders for Qorvo products. The information contained herein or any use of such information does not grant, explicitly or implicitly, to any party any patent rights, licenses, or any other intellectual property rights, whether with regard to such information itself or anything described by such information. **THIS INFORMATION DOES NOT CONSTITUTE A WARRANTY WITH RESPECT TO THE PRODUCTS DESCRIBED HEREIN, AND QORVO HEREBY DISCLAIMS ANY AND ALL WARRANTIES WITH RESPECT TO SUCH PRODUCTS WHETHER EXPRESS OR IMPLIED BY LAW, COURSE OF DEALING, COURSE OF PERFORMANCE, USAGE OF TRADE OR OTHERWISE, INCLUDING THE IMPLIED WARRANTIES OF MERCHANTABILITY AND FITNESS FOR A PARTICULAR PURPOSE.**

Without limiting the generality of the foregoing, Qorvo products are not warranted or authorized for use as critical components in medical, life-saving, or life-sustaining applications, or other applications where a failure would reasonably be expected to cause severe personal injury or death.

© 2020 Qorvo US, Inc. All rights reserved. This document is subject to copyright laws in various jurisdictions worldwide and may not be reproduced or distributed, in whole or in part, without the express written consent of Qorvo US, Inc.

Looking for pricing, stock, or lifecycle information?

Click below to explore more details on WIN SOURCE:

 [View TGA2624-SMTR7 on WIN SOURCE](#)

 [Qorvo US Inc. Information](#)

Optimize Your Supply Chain with WIN SOURCE Solutions

-  Global Sourcing Solution
-  Obsolete Management
-  Cost Control Management
-  Shortage Management
-  Alternative Solution
-  Excess Inventory Management