

Product Overview

The CMD249 is wideband GaAs MMIC distributed power amplifier die which operates from DC to 20 GHz. The amplifier delivers greater than 12 dB of gain with a corresponding output 1 dB compression point of +30 dBm and output IP3 of 38 dBm at 10 GHz. The CMD249 is a 50 ohm matched design which eliminates the need for RF port matching. The CMD249 offers full passivation for increased reliability and moisture protection.

Functional Block Diagram

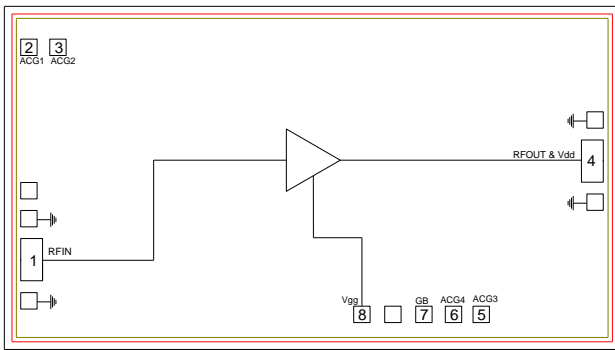

Key Features

- Ultra Wideband Performance
- High Linearity
- High Output Power
- Excellent Return Losses
- Small Die Size

Ordering Information

| Part No. | Description |
|----------|--|
| CMD249 | DC - 20 GHz Distributed Power Amplifier, 25 Piece Gel Pack |

Electrical Performance ($V_{dd} = 10.0\text{ V}$, $V_{gg} = -0.95\text{ V}$, $T_A = 25\text{ }^\circ\text{C}$, $F = 10\text{ GHz}$)

| Parameter | Min | Typ | Max | Units |
|--------------------|-----|---------|-----|-------|
| Frequency Range | | DC - 20 | | GHz |
| Gain | | 13 | | dB |
| Noise Figure | | 3.4 | | dB |
| Input Return Loss | | 16 | | dB |
| Output Return Loss | | 17 | | dB |
| Output P1dB | | 30 | | dBm |
| Supply Current | | 400 | | mA |

Absolute Maximum Ratings

| Parameter | Rating |
|-----------------------------------|---------------|
| Drain Voltage, V_{dd} | 10.5 V |
| Gate Voltage, V_{gg} | -2.0 to 0 V |
| RF Input Power | +30 dBm |
| Channel Temperature, T_{ch} | 150 °C |
| Power Dissipation, P_{diss} | 4 W |
| Thermal Resistance, θ_{JC} | 16.25 °C/W |
| Operating Temperature | -55 to 85 °C |
| Storage Temperature | -55 to 150 °C |

Exceeding any one or combination of the maximum ratings may cause permanent damage to the device.

Recommended Operating Conditions

| Parameter | Min | Typ | Max | Units |
|-----------|-----|-------|------|-------|
| V_{dd} | 8.0 | 10.0 | 10.5 | V |
| I_{dd} | 350 | 400 | 450 | mA |
| V_{gg} | | -0.95 | | V |
| I_{gg} | | -2.5 | | mA |

Electrical performance is measured at specific test conditions. Electrical specifications are not guaranteed over all recommended operating conditions.

Electrical Specifications ($V_{dd} = 10.0$ V, $V_{gg} = -0.95$ V, $T_A = 25$ °C)

| Parameter | Min | Typ | Max | Min | Typ | Max | Units |
|--------------------------------------|--------|-------|-----|--------|-------|-----|-------|
| Frequency Range | DC - 6 | | | 6 - 20 | | | GHz |
| Gain | 10.5 | 13 | | 11 | 13.5 | | dB |
| Noise Figure | | 5 | | | 3.5 | | dB |
| Input Return Loss | | 15 | | | 17 | | dB |
| Output Return Loss | | 10 | | | 18 | | dB |
| Output P1dB | 28 | 30 | | 27 | 29.5 | | dBm |
| Output IP3 | | 40 | | | 35 | | dBm |
| Supply Current | 300 | 400 | 500 | 300 | 400 | 500 | mA |
| Gain Temperature Coefficient | | 0.009 | | | 0.014 | | dB/°C |
| Noise Figure Temperature Coefficient | | 0.01 | | | 0.012 | | dB/°C |

Typical Performance

Broadband Performance, $V_{dd} = 10\text{ V}$, $V_{gg} = -0.95\text{ V}$, $I_{dd} = 400\text{ mA}$, $T_A = 25\text{ °C}$

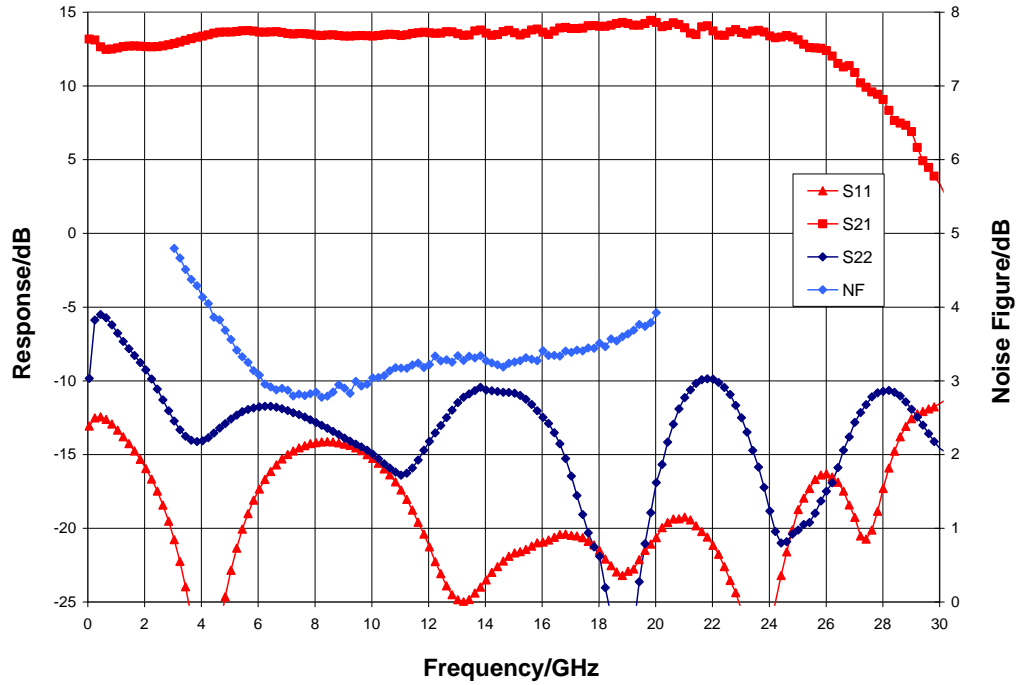

Narrow-band Performance, $V_{dd} = 10\text{ V}$, $V_{gg} = -0.95\text{ V}$, $I_{dd} = 400\text{ mA}$, $T = 25\text{ °C}$

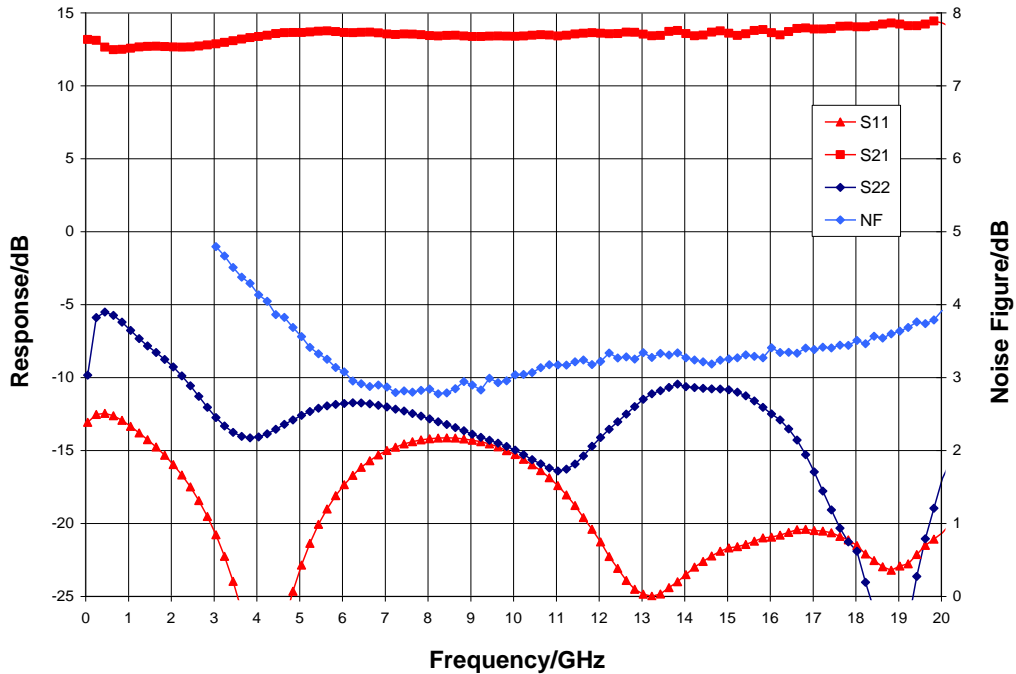

Typical Performance

Gain vs. Temperature, $V_{dd} = 10\text{ V}$, $V_{gg} = -0.95\text{ V}$

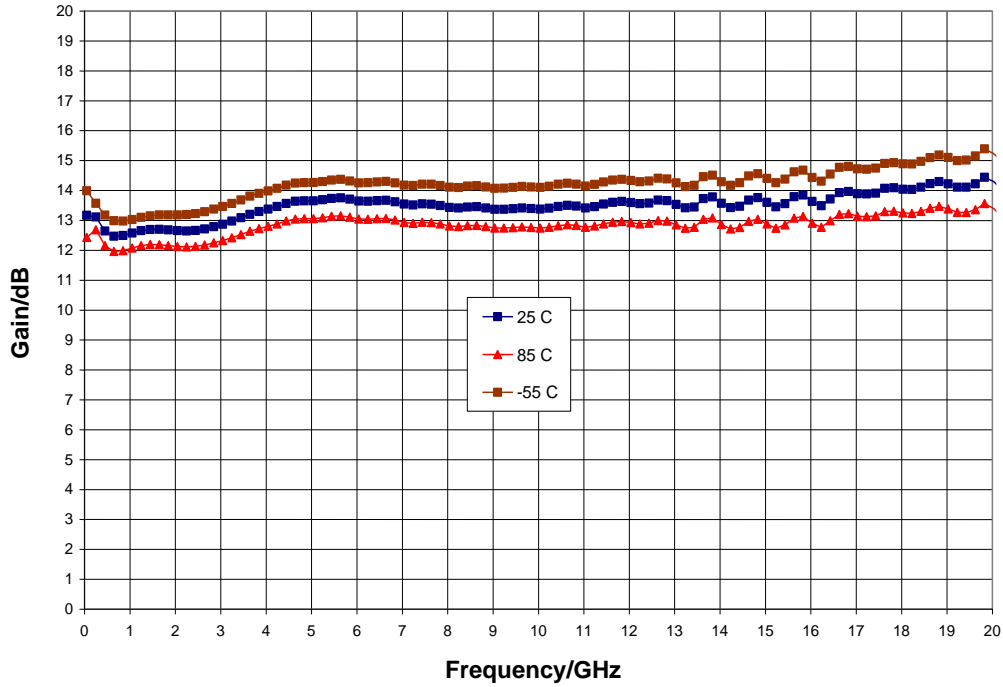

Noise Figure vs. Temperature, $V_{dd} = 10\text{ V}$, $V_{gg} = -0.95\text{ V}$

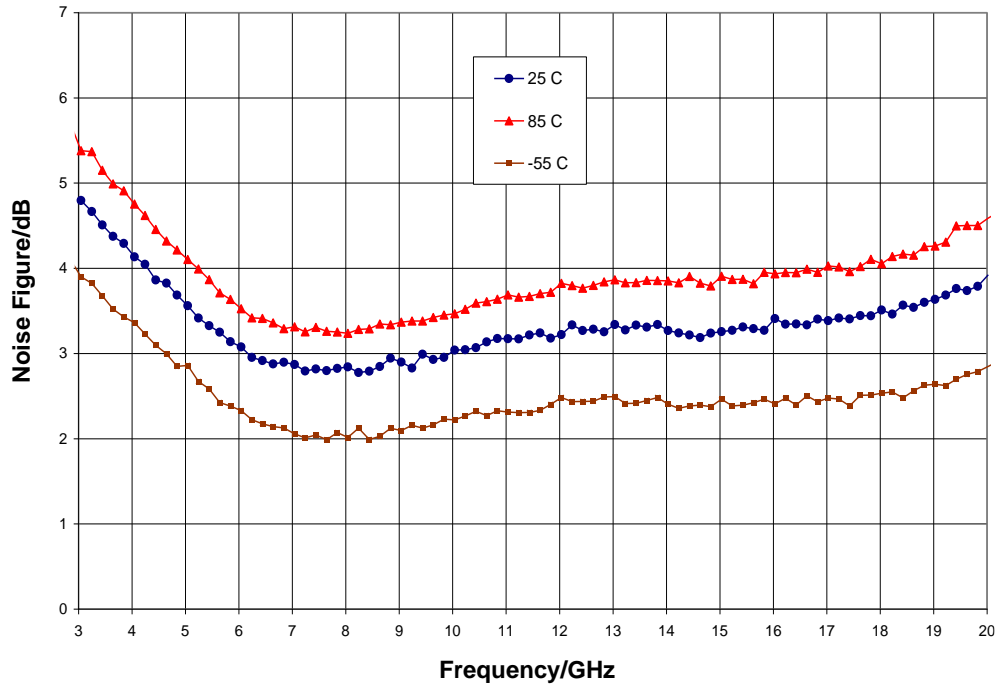

Typical Performance

Output Power, $V_{dd} = 10\text{ V}$, $V_{gg} = -0.95\text{ V}$, $T_A = 25\text{ }^\circ\text{C}$

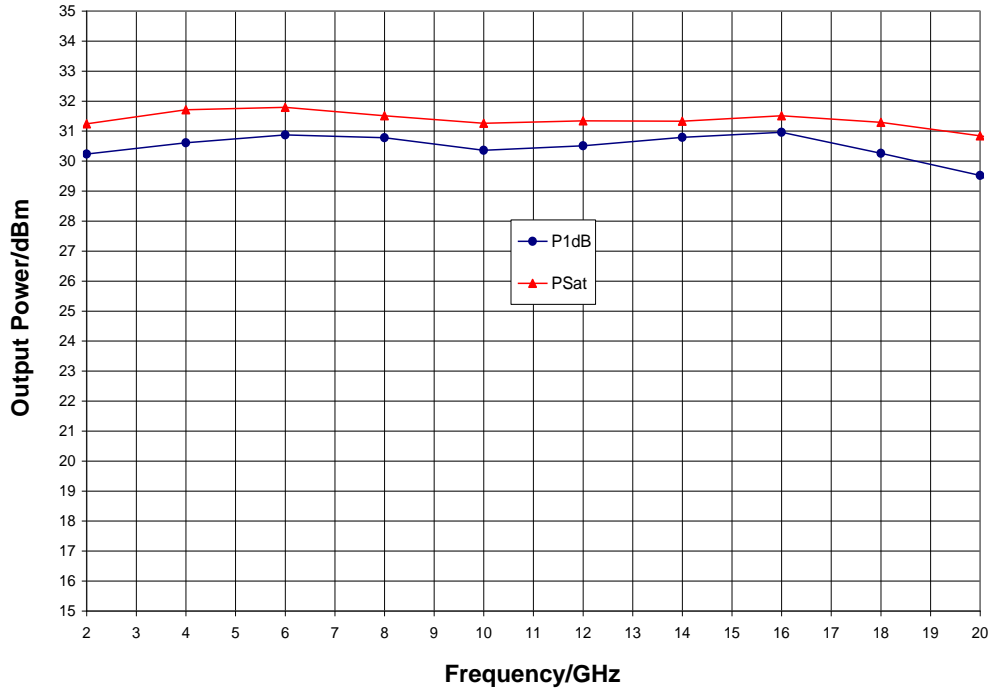

P1dB vs. Temperature, $V_{dd} = 10\text{ V}$, $V_{gg} = -0.95\text{ V}$

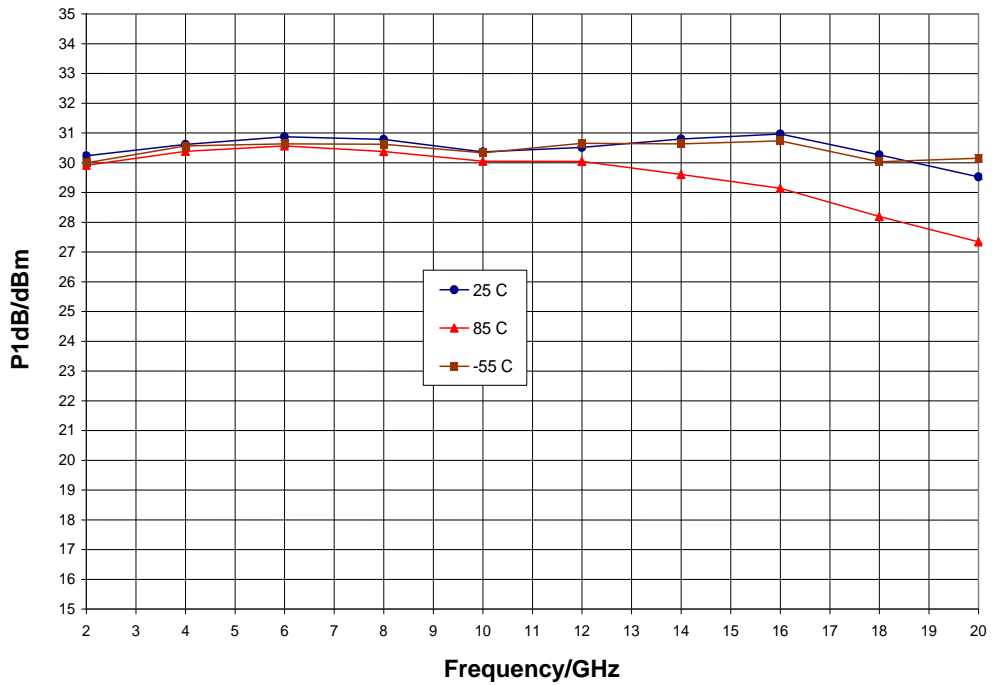

Typical Performance

Output IP3 vs. Temperature, $V_{dd} = 10\text{ V}$, $V_{gg} = -0.95\text{ V}$

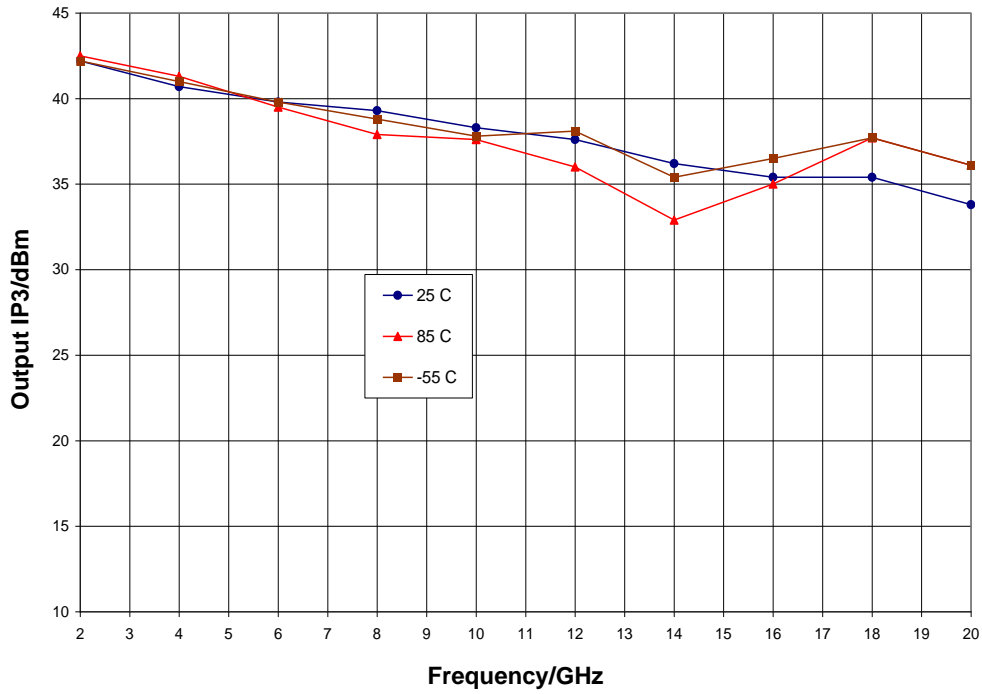

Mechanical Information

Die Outline (all dimensions in microns)

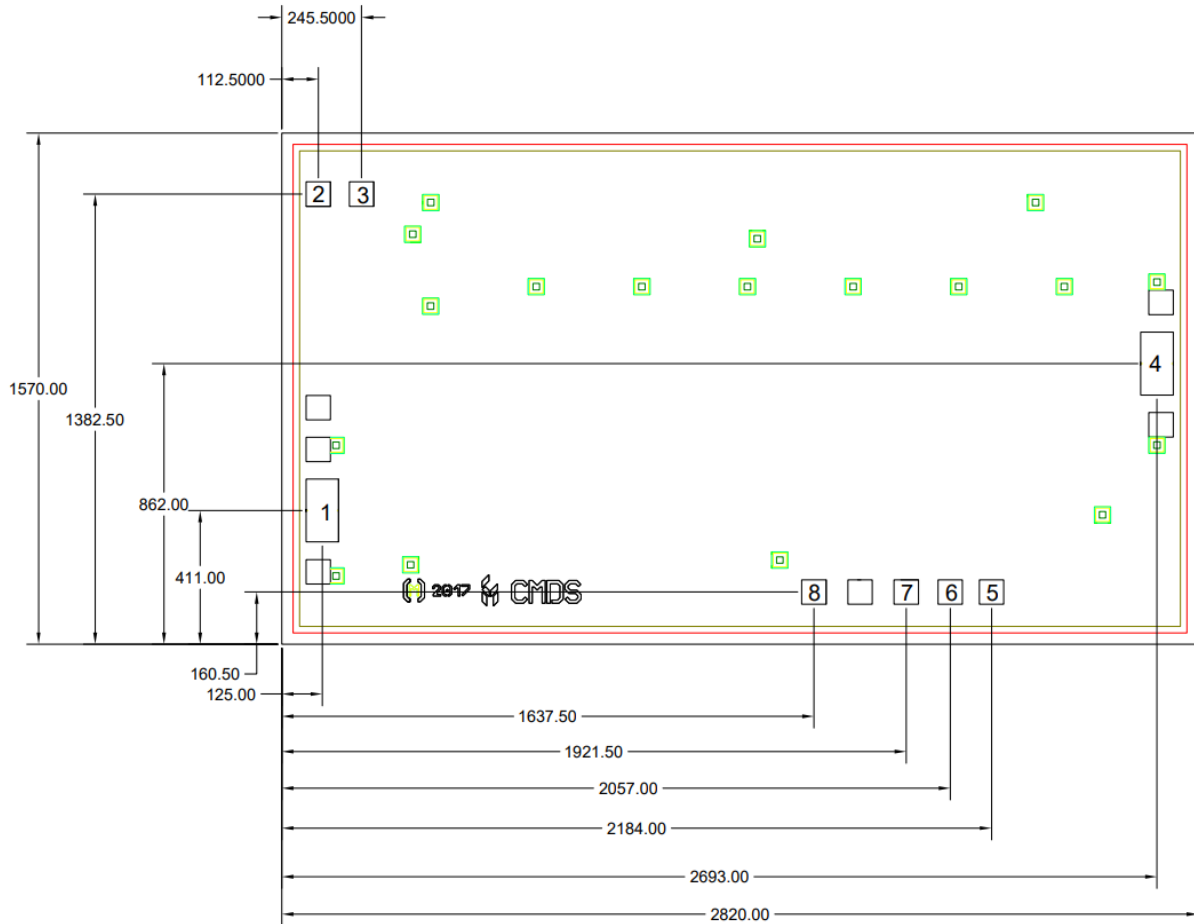

Notes:

1. No connection required for unlabeled pads
2. Backside is RF and DC ground
3. Backside and bond pad metal: Gold
4. Die is 70 microns thick
5. DC bond pads (2, 3, 5, 6, 7, and 8) are 78 microns square
6. RF bond pads (1 and 4) are 108 x 193 microns

Pad Description

Pad Diagram



Functional Description

| Pad | Function | Description | Schematic |
|----------|--------------------------|--|-----------|
| 1 | RF in | 50 ohm matched input | |
| 2, 3 | ACG1, 2 | Low frequency termination Attach bypass capacitor per application circuit | |
| 4 | RF out & V _{dd} | Power supply voltage and 50 ohm matched output | |
| 5, 6 | ACG3, 4 | Low frequency termination Attach bypass capacitor per application circuit | |
| 7 | GB | Connect to DC ground | |
| 8 | V _{gg} | Power supply voltage Decoupling and bypass caps required | |
| Backside | Ground | Connect to RF / DC ground | |

Applications Information

Assembly Guidelines

The backside of the CMD249 is RF ground. Die attach should be accomplished with electrically and thermally conductive epoxy only. Eutectic attach is not recommended. Standard assembly procedures should be followed for high frequency devices. The top surface of the semiconductor should be made planar to the adjacent RF transmission lines, and the RF decoupling capacitors placed in close proximity to the DC connections on chip.

RF connections should be made as short as possible to reduce the inductive effect of the bond wire. Use of a 0.8 mil thermosonic wedge bonding is highly recommended as the loop height will be minimized. The RF input and output require a double bond wire as shown.

The semiconductor is 70 um thick and should be handled by the sides of the die or with a custom collet. Do not make contact directly with the die surface as this will damage the monolithic circuitry. Handle with care.

Assembly Diagram

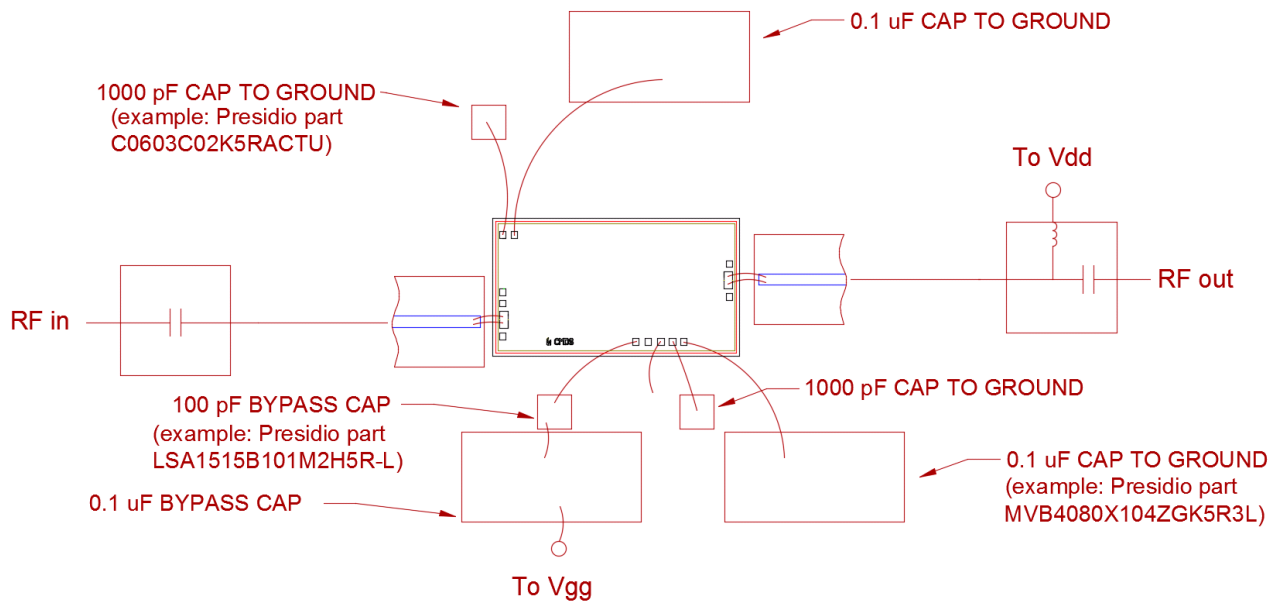

GaAs MMIC devices are susceptible to damage from Electrostatic Discharge. Proper precautions should be observed during handling, assembly and test.

Applications Information

Application Circuit

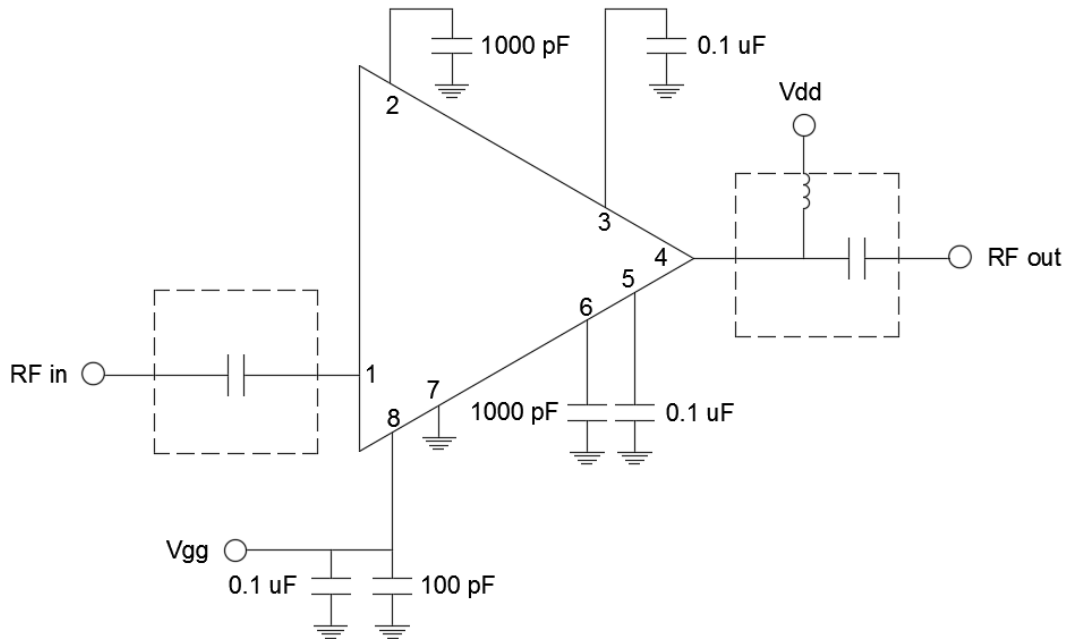

Note: Drain voltage (V_{dd}) must be applied through a broadband bias tee or external bias network. External DC block is required on RF input.

Biasing and Operation

The CMD249 is biased with a positive drain supply and a negative gate supply. Performance is optimized when the drain voltage is set to +10 V. The nominal gate voltage is -0.95 V.

Turn ON procedure:

1. Apply gate voltage V_{gg} and set to -2 V
2. Apply drain voltage V_{dd} and set to +10 V
3. Increase V_{gg} (less negative) to achieve a drain current of 400 mA

Turn OFF procedure:

1. Turn off drain voltage V_{dd}
2. Turn off gate voltage V_{gg}

RF power can be applied at any time.

Handling Precautions

| Parameter | Rating | Standard |
|------------------------------|----------|--------------------------|
| ESD – Human Body Model (HBM) | Class 1A | ESDA / JEDEC JS-001-2012 |



Caution!
 ESD-Sensitive Device

RoHS Compliance

This part is compliant with 2011/65/EU RoHS directive (Restrictions on the Use of Certain Hazardous Substances in Electrical and Electronic Equipment) as amended by Directive 2015/863/EU.

This product also has the following attributes:

- Lead Free
- Antimony Free
- TBBP-A (C₁₅H₁₂Br₄O₂) Free
- SVHC Free
- Halogen Free
- PFOS Free

Contact Information

For the latest specifications, additional product information, worldwide sales and distribution locations:

Web: www.qorvo.com

Tel: 1-844-890-8163

Email: customer.support@qorvo.com

Important Notice

The information contained in this Data Sheet and any associated documents (“Data Sheet Information”) is believed to be reliable; however, Qorvo makes no warranties regarding the Data Sheet Information and assumes no responsibility or liability whatsoever for the use of said information. All Data Sheet Information is subject to change without notice. Customers should obtain and verify the latest relevant Data Sheet Information before placing orders for Qorvo® products. Data Sheet Information or the use thereof does not grant, explicitly, implicitly or otherwise any rights or licenses to any third party with respect to patents or any other intellectual property whether with regard to such Data Sheet Information itself or anything described by such information.

DATA SHEET INFORMATION DOES NOT CONSTITUTE A WARRANTY WITH RESPECT TO THE PRODUCTS DESCRIBED HEREIN, AND QORVO HEREBY DISCLAIMS ANY AND ALL WARRANTIES WITH RESPECT TO SUCH PRODUCTS WHETHER EXPRESS OR IMPLIED BY LAW, COURSE OF DEALING, COURSE OF PERFORMANCE, USAGE OF TRADE OR OTHERWISE, INCLUDING THE IMPLIED WARRANTIES OF MERCHANTABILITY AND FITNESS FOR A PARTICULAR PURPOSE. Without limiting the generality of the foregoing, Qorvo® products are not warranted or authorized for use as critical components in medical, life-saving, or life-sustaining applications, or other applications where a failure would reasonably be expected to cause severe personal injury or death. Applications described in the Data Sheet Information are for illustrative purposes only. Customers are responsible for validating that a particular product described in the Data Sheet Information is suitable for use in a particular application.

© 2022 Qorvo US, Inc. All rights reserved. This document is subject to copyright laws in various jurisdictions worldwide and may not be reproduced or distributed, in whole or in part, without the express written consent of Qorvo US, Inc. | QORVO® is a registered trademark of Qorvo US, Inc.

Looking for pricing, stock, or lifecycle information?

Click below to explore more details on WIN SOURCE:

 [View CMD249 on WIN SOURCE](#)

 [Qorvo US Inc. Information](#)

Optimize Your Supply Chain with WIN SOURCE Solutions

-  Global Sourcing Solution
-  Obsolete Management
-  Cost Control Management
-  Shortage Management
-  Alternative Solution
-  Excess Inventory Management