

MMA-012727-M4 0.1-26.5GHz 0.5W Traveling Wave Amplifier

Features:

- Frequency Range: 0.1 – 26.5 GHz
- P3dB: +27 dBm
- Gain: 12.5 dB
- Vdd =8 to 12 V
- Ids =250 to 500 mA
- Input and Output Fully Matched to 50 Ω
- Surface Mount, RoHS Compliant QFN 4x4mm package

Applications:

- Fiber optics communication systems
- Microwave and wireless communication systems
- Microwave and optical instrumentations

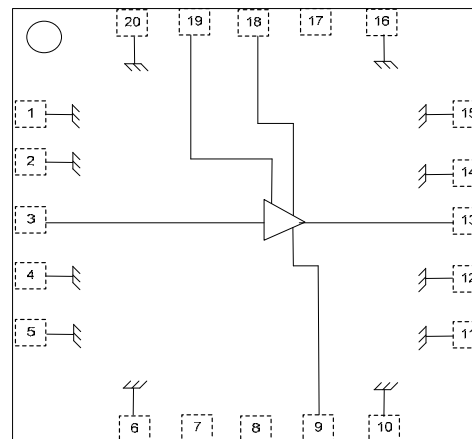

Functional block diagram

Description:

The MMA-012727-M4 is a broadband GaAs MMIC Traveling Wave Amplifier (TWA) with medium output power and high gain over 0.1 to 26.5GHz frequency range. This amplifier is optimally designed for broadband applications requiring flat gain and high power with excellent input and output matches over a 0.1 to 26.5GHz frequency range.

Absolute Maximum Ratings: $(T_a = 25\text{ }^\circ\text{C})^*$

SYMBOL	PARAMETERS	UNITS	Min.	Max.
Vds	Drain-Source Voltage	V		12.5
Vg1	First Gate-Source Voltage	V	-2	0
Ig1	First Gate Current	mA	-10	1
Vg2	Second Gate-Source Voltage	V	-3.5	6
Ig2	Second Gate-Source Current	mA	-20	
Pdiss	Maximum Power dissipation	W		4.65
Pin max	RF Input Power	dBm		23
Toper	Operating Temperature	°C		-40 to +85
Tch	Channel Temperature	°C		+150
Tstg	Storage Temperature	°C		-55 to +165
Tmax	Max. Assembly Temp (60 sec max)	°C		+300

*Operation of this device above any one of these parameters may cause permanent damage.

MMA-012727-M4

0.1-26.5GHz 0.5W Traveling Wave Amplifier

Electrical Specifications: *V_{ds}=10V, V_{g1}=-0.75V, V_{g2}=1V, I_{ds}=350mA, T_a=25 °C Z₀=50 ohm*

Parameter	Units	Min.	Typ.	Max.
Frequency Range	MHz	0.1		26,500
Gain (Typ / Min)	dB	11.5	12.5	
Gain Flatness (Typ / Max)	+/-dB		0.5	0.7
Input RL(Typ/Max)	dB	9	11	
Output RL(Typ/Max)	dB	9	11	
Output P1dB(Typ/Min)	dBm	22	26	
Output IP3 ⁽¹⁾	dBm		35	
Output P3dB(Typ/Min)	dBm	23	27	
Operating Current at P1dB (Typ/Max)	mA		350	380
Thermal Resistance	°C /W		14	

(1) Output IP3 is measured with two tones at output power of 10 dBm/tone separated by 20 MHz.

MMA-012727-M4

0.1-26.5GHz 0.5W Traveling Wave Amplifier

Typical RF Performance: $V_{ds}=10V$, $V_{g1}=-0.75V$, $V_{g2}=1V$, $I_{ds}=350mA$, $Z_0=50\text{ ohm}$, $T_a=25\text{ }^\circ\text{C}$

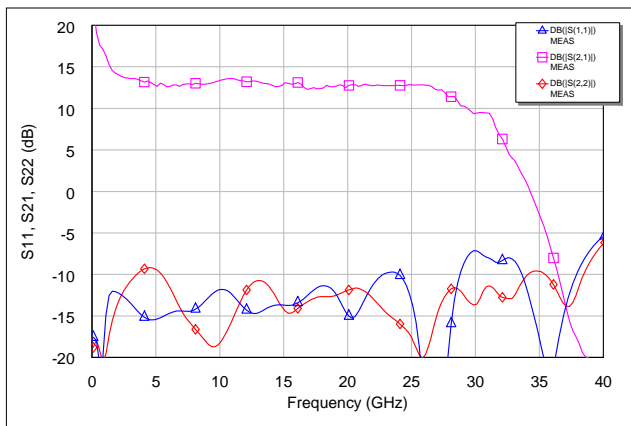

S11, S21, and S22 vs. Frequency

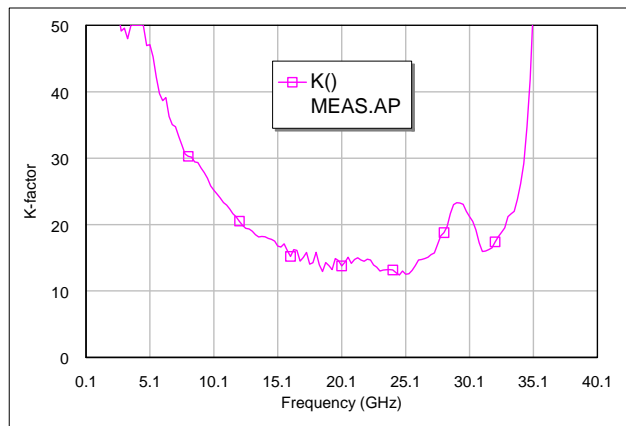

K-factor vs. Frequency

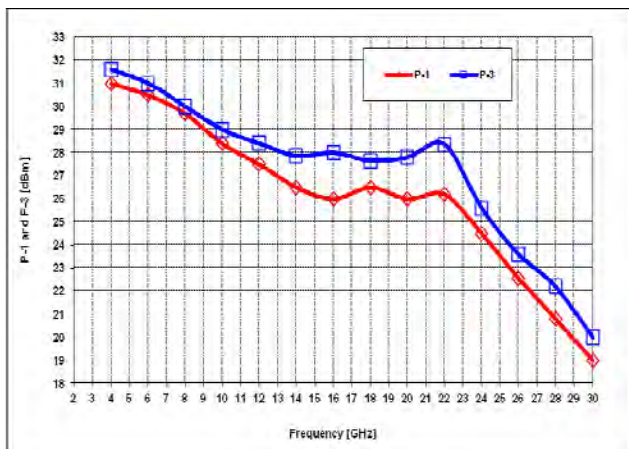

P-1 and P-3 vs. Frequency

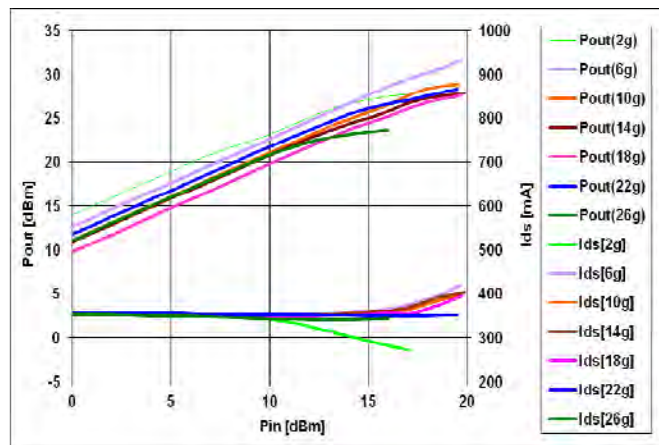

Pout and Ids vs. Pin

MMA-012727-M4

0.1-26.5GHz 0.5W Traveling Wave Amplifier

Applications

The **MMA-012727-M4** traveling wave amplifier is designed for use as a general purpose wideband power stage in microwave communication systems, and test equipments. It is ideally suited for broadband applications requiring a flat gain response and excellent port matches over a 0.1 to 26.5 GHz frequency range. Dynamic gain control and low-frequency extension capabilities are designed into these devices.

Biasing and Operation

The recommended bias conditions for best performance for the **MMA-012727-M4** are $V_{DD} = 10V$, $I_{DD} = 350mA$. To achieve these drain current levels, V_{g1} is typically $-0.75V$, and V_{g2} is typically $+1V$. No other bias supplies or connections to the device are required for 0.1 to 26.5 GHz operation. The gate voltage (V_{g1}) should be applied prior to the drain voltage (V_{d1}) during power up and removed after the drain voltage during power down. Performance improvements are possible depending on applications. The drain bias voltage range is 8 to 12V and the quiescent drain current biasing range is 250mA to 500mA. The **MMA-012727-M4** is a DC coupled amplifier. External coupling capacitors are needed on RF IN and RF OUT ports. The drain bias pad is connected to RF and must be decoupled to the lowest operating frequency. An auxiliary drain contacts is provided when performance below 2GHz is required. The second gate (V_{g2}) can be used to obtain 30 dB (typical) dynamic gain control. For maximum gain operation, typical V_{g2} is $+1V$.

Assembly Techniques

GaAs MMICs are ESD sensitive. ESD preventive measures must be employed in all aspects of storage, handling, and assembly. MMIC ESD precautions, handling considerations, die attach and bonding methods are critical factors in successful GaAs MMIC performance and reliability.

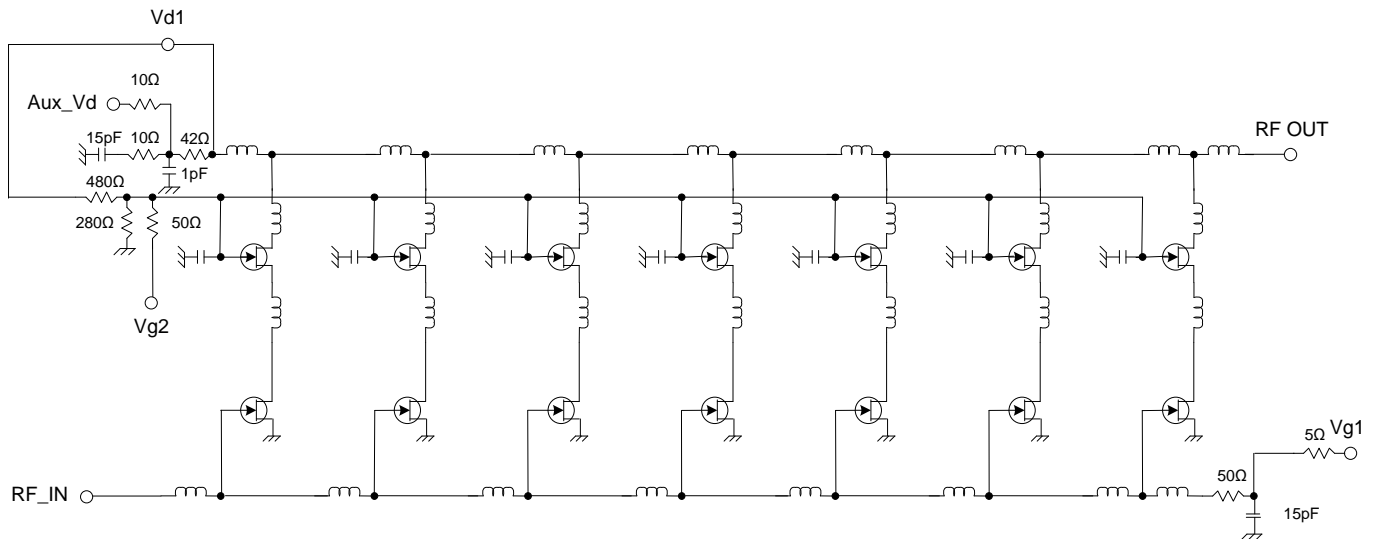

MMA-012727-M4

0.1-26.5GHz 0.5W Traveling Wave Amplifier

Outline Drawing

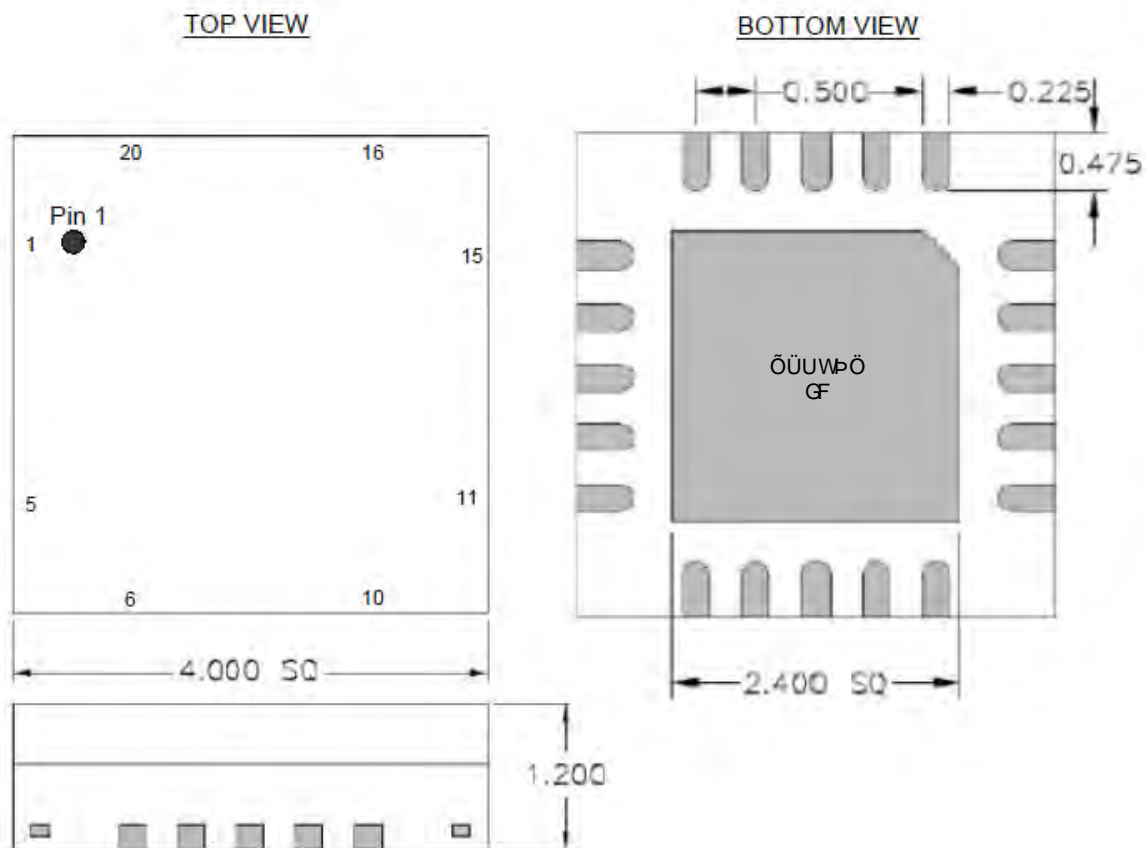

The units are in [mm].

Pin	Description
3	RF Input
13	RF Output/Vdd
9	Vg1
18	Vg2
19	Vdd_Aux
1, 2, 4, 5, 6, 10, 11, 12, 14, 15, 16, 20, 21	Ground
7, 8, 17	N/C

MMA-012727-M4

0.1-26.5GHz 0.5W Traveling Wave Amplifier

Application Circuit:

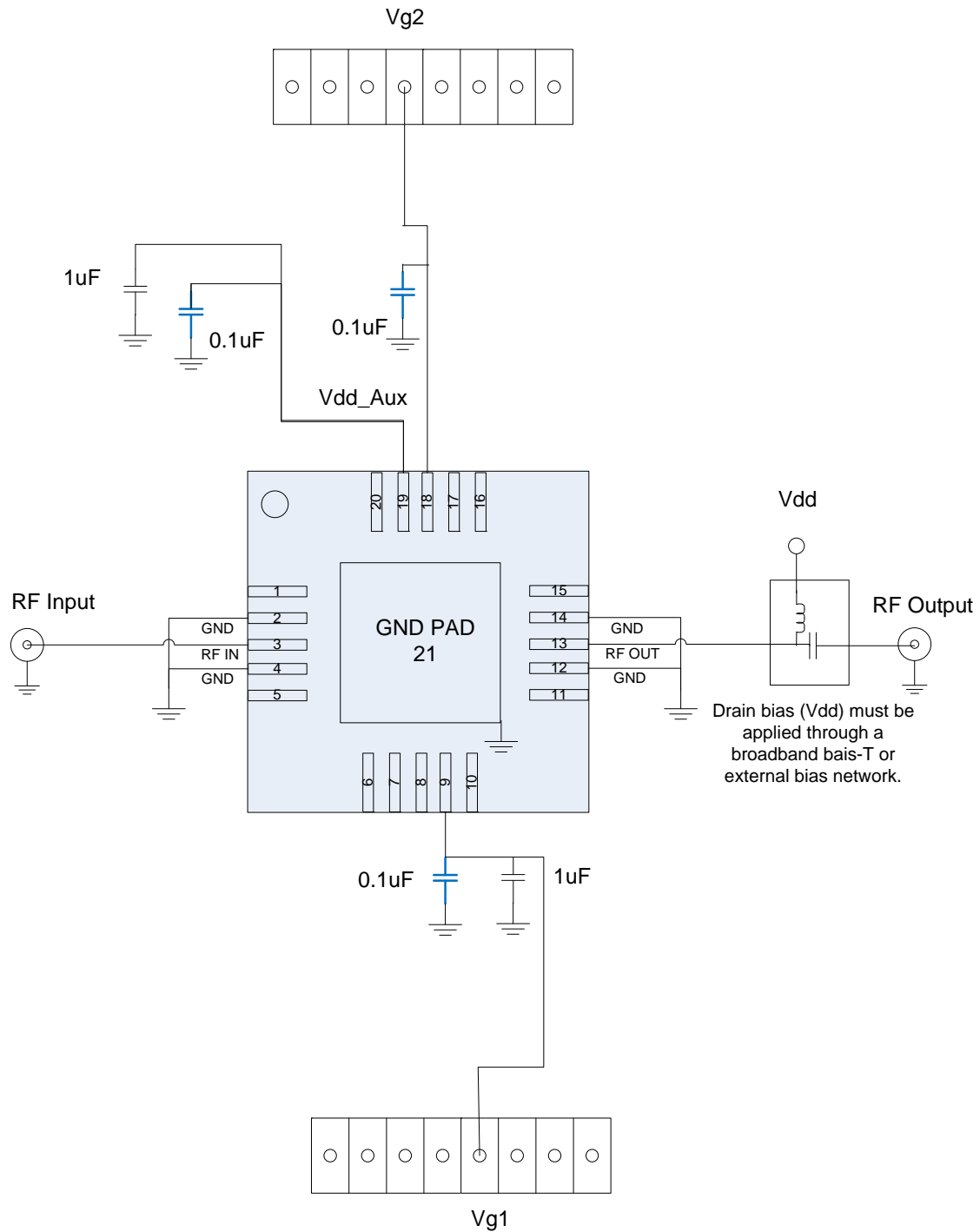

MMA-012727-M4

0.1-26.5GHz 0.5W Traveling Wave Amplifier

Recommended Application Board Design:

Board Material is 10mil (Dielectric) thickness Rogers 4350B with 0.5oz copper clads.

Board is soldered on a gold plated solid copper block and adequate heat-sinking is required for 3.4W total maximum power dissipation.

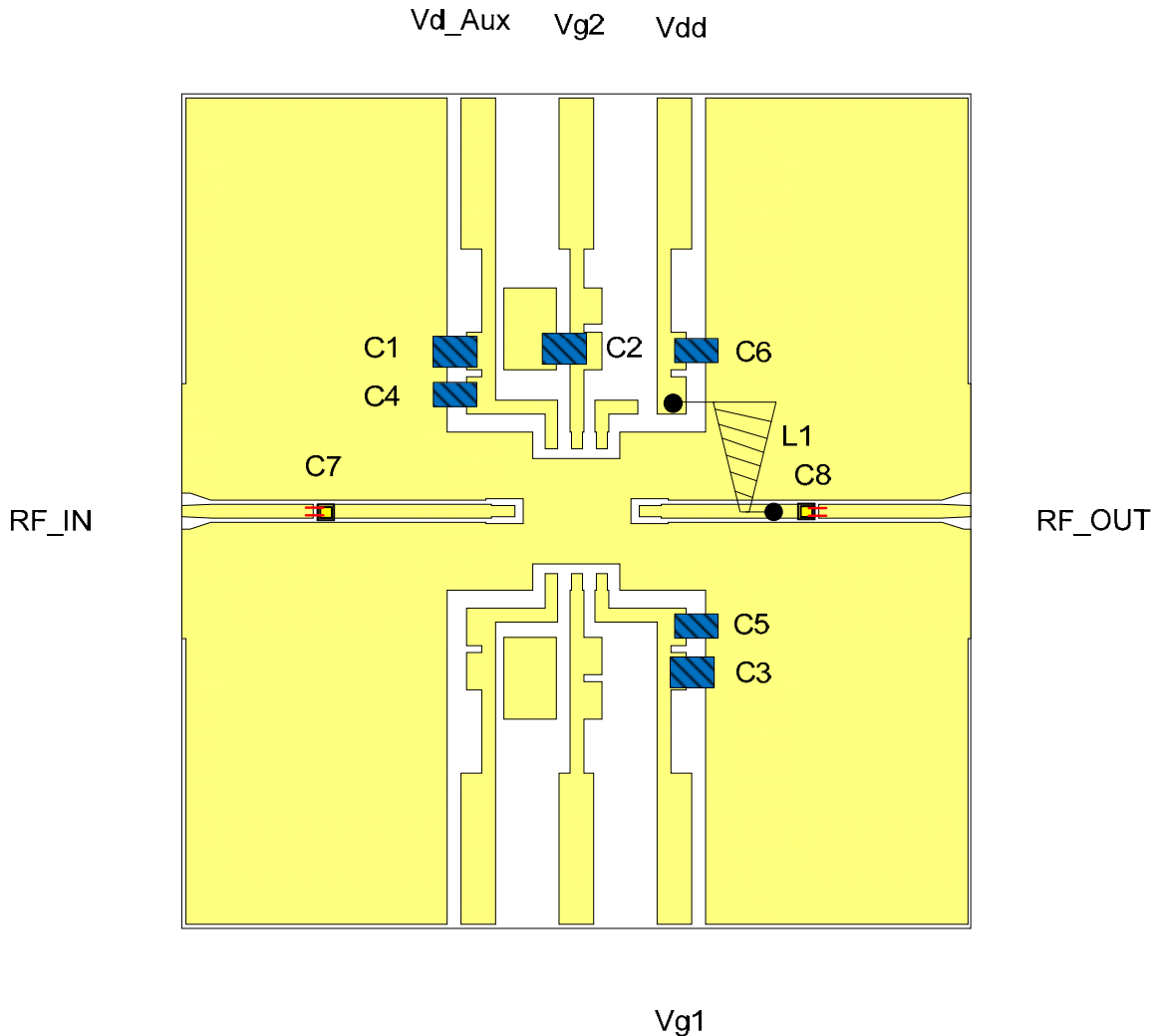

Part	Value	Description
C1, C3	1uF	0603
C2, C4, C5, C6	0.1uF	0402
C7, C8	100pF	Presidio LSB1515B101M2H5R-B
L1	0.26uH	GOWANDA C100FL1938G6

MMA-012727-M4

0.1-26.5GHz 0.5W Traveling Wave Amplifier

Recommended Application Board Design:

Board Material is 10mil (Dielectric) thickness Rogers 4350B with 0.5oz copper clads. The board material and mounting pattern, as defined in the data sheet, optimizes RF performance and is strongly recommended.

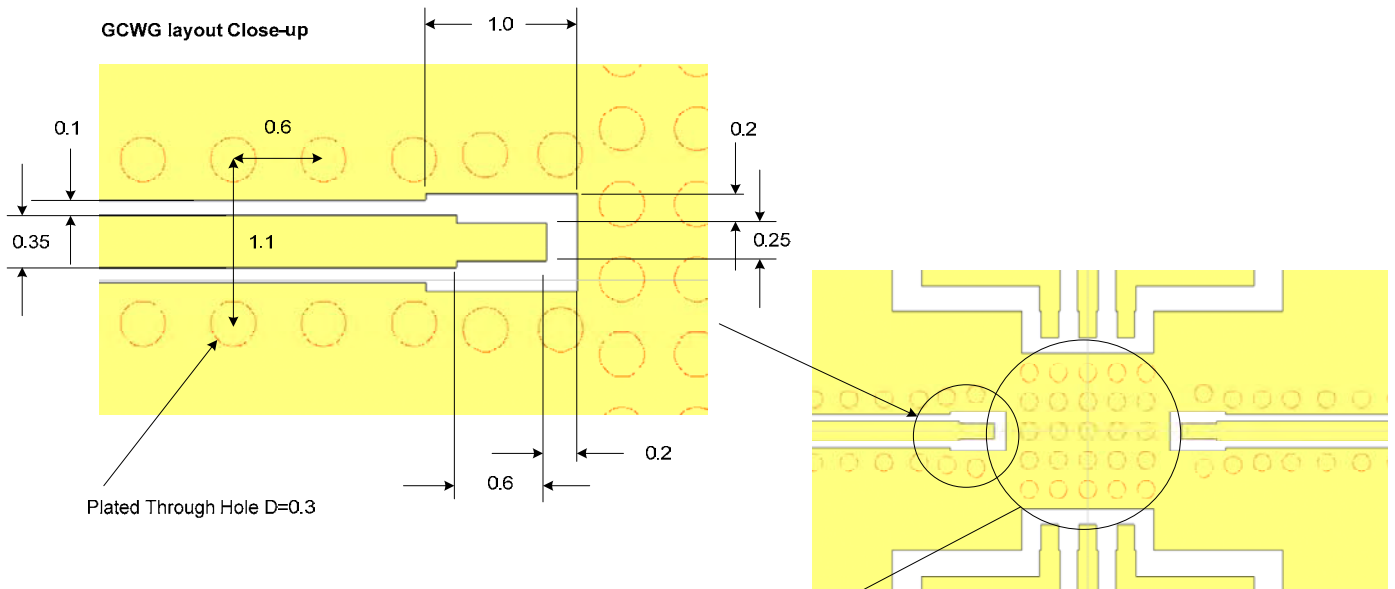

Plated Through Hole D=0.3

Underneath of the package must be
Copper filled plated through holes.
D=0.3mm and Space=0.5mm
Total Via-holes = 5 x 5

All units are in millimeters.

Copper filled thru vias
D=0.3mm, Space=0.5mm
7x7

For best thermal
dissipation, 3mm square
Copper filled PCB is
recommended.

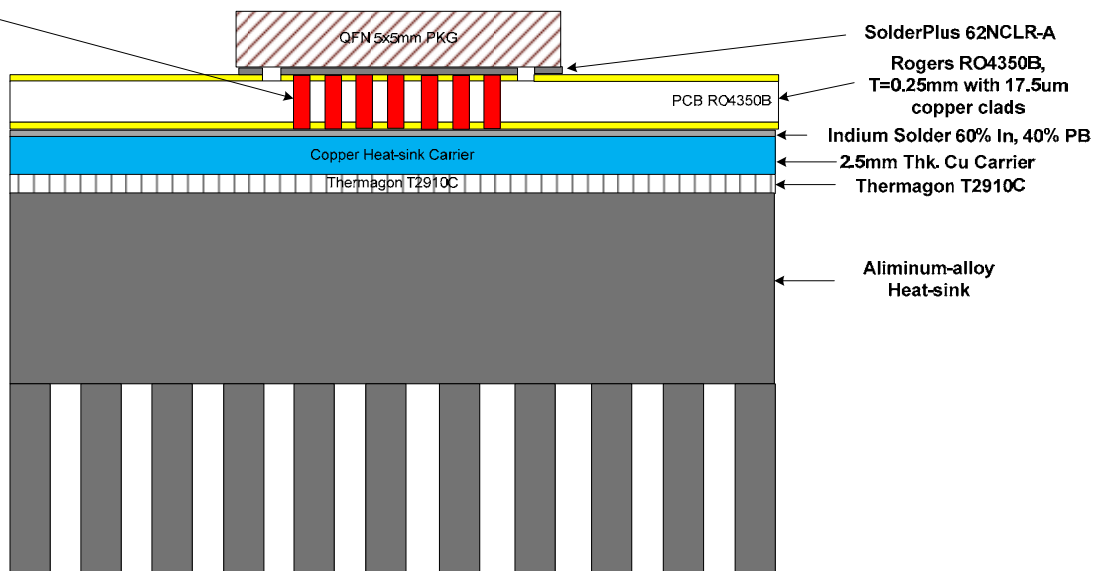

MMA-012727-M4

0.1-26.5GHz 0.5W Traveling Wave Amplifier

Contact Information

For additional information please visit www.cmlmicro.com or contact a sales office.



Europe	America	Asia
<ul style="list-style-type: none">• Maldon, UK• Tel +44 (0) 1621 875500• sales@cmlmicro.com	<ul style="list-style-type: none">• Winston-Salem, NC• Tel +1 336 744 5050• us.sales@cmlmicro.com	<ul style="list-style-type: none">• Singapore• Tel +65 6288129• sg.sales@cmlmicro.com

Although the information contained in this document is believed to be accurate, no responsibility is assumed by CML for its use. The product and product information is subject to change at any time without notice. CML has a policy of testing every product shipped using calibrated test equipment to ensure compliance with product specification.

© 2017 CML Microsystems Plc

Looking for pricing, stock, or lifecycle information?

Click below to explore more details on WIN SOURCE:

-  [View MMA-012727-M4 on WIN SOURCE](#)
-  [CML Microcircuits Information](#)

Optimize Your Supply Chain with WIN SOURCE Solutions

-  Global Sourcing Solution
-  Obsolete Management
-  Cost Control Management
-  Shortage Management
-  Alternative Solution
-  Excess Inventory Management