

MMA-011015-C3 1 - 10 GHz Fully Matched Driver Amplifier

Features:

- Frequency Range: 1 – 10 GHz
- P-1dB: 16dBm
- Gain: 15dB
- Single Positive Bias: + 6V
- Fully Matched Input/Output to 50 ohms
- Advanced 0.25 um AlGaAs / InGaAs PHEMT Technology with Excellent Reliability
- Surface Mount 3.0 X 3.0 X 0.8 mm Package

Description:

The MMA-011015-C3 is a 1-10 GHz broadband MMIC driver amplifier fabricated with advanced 0.25 um AlGaAs / InGaAs PHEMT technology with excellent reliability. The fully matched MMIC amplifier is easy to cascade with other stages and is unconditionally stable. The typical applications include test instrumentation, and commercial wireless equipment, etc.

Electrical Specifications: (V_{ds} = 6.0V, I_{ds}=75mA, Z_o=50 ohm, T_A=25 °C)

Parameter	Units	Min.	Typ.	Max.
Frequency Range (Min/Max)	GHz	1		10
Small Signal Gain	dB	10	15	
Gain Flatness	+/-dB		2.5	
Input Return Loss	dB		-10	
Output Return Loss	dB		-10	
Output P1dB	dBm		+16	
Noise Figure	dB		4.5	
Quiescent Current	mA		75	
Thermal Resistance	°C/W		120	

Typical RF Performance: ($V_{ds} = 6.0V$, $I_{ds} = 75mA$, $T_A = 25^\circ C$, 50 Ohm system unless stated otherwise)

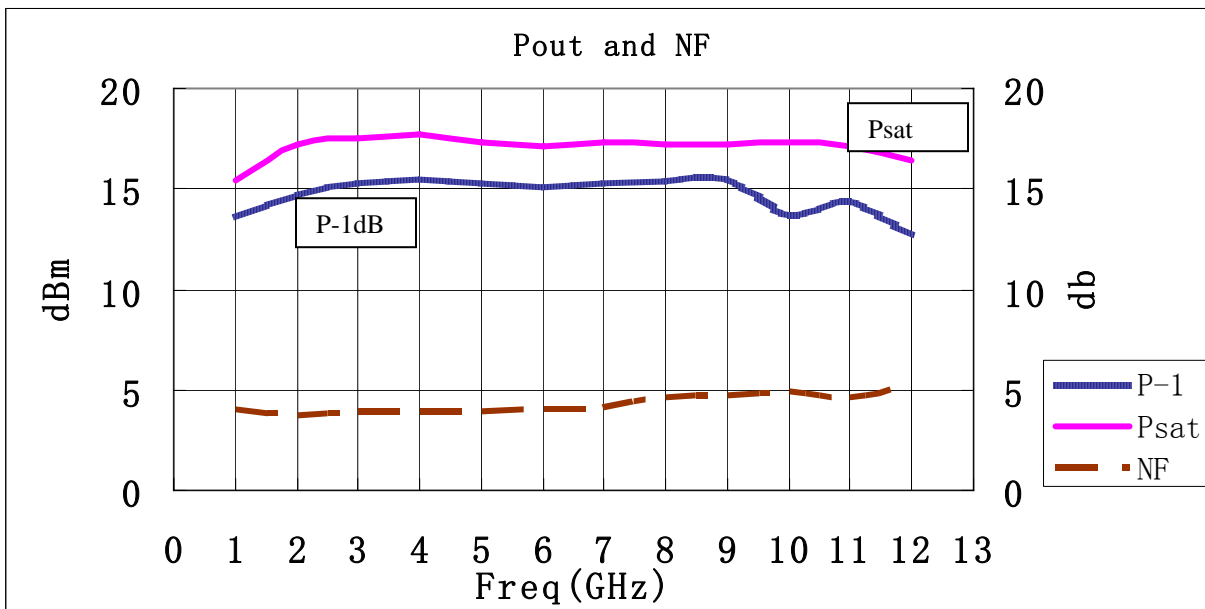
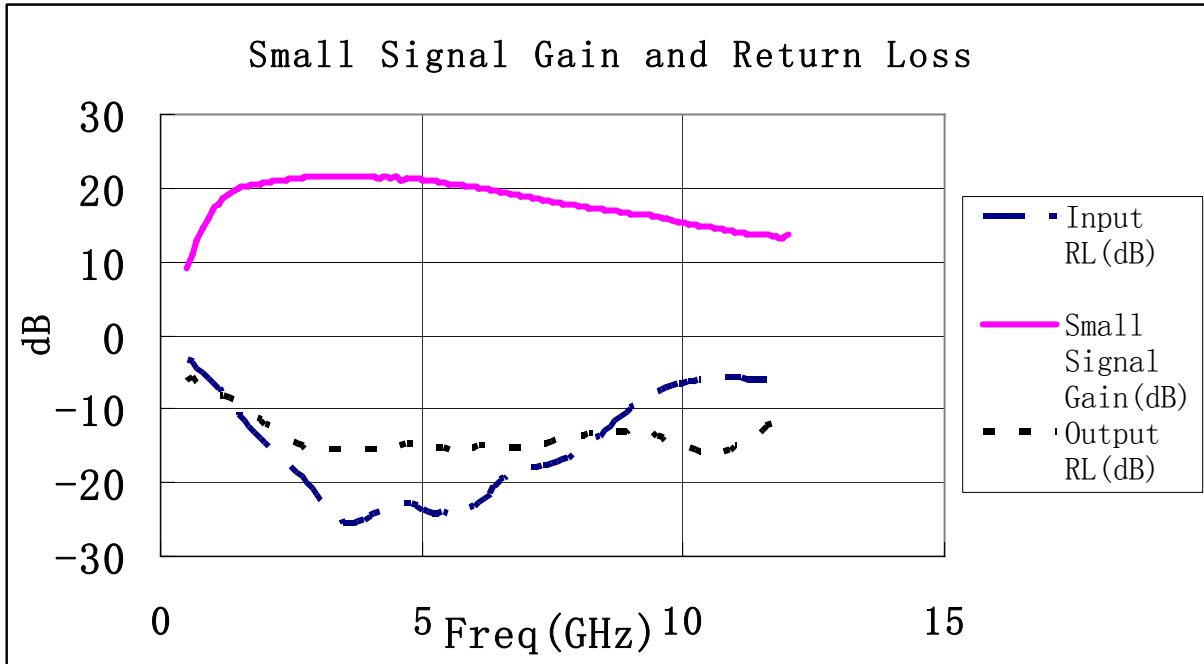

S-parameters: (V_{ds} = 6.0V, I_{ds}=75mA, T_A=25 °C, 50 Ohm system)

Freq(GHz)	magS11	angS11	magS21	angS21	magS12	angS12	magS22	angS22
1.0	0.47	-174.2	7.00	-9.38	0.006	84.91	0.42	18.93
1.5	0.29	120.5	9.87	-74.03	0.014	-18.02	0.33	-81.20
2.0	0.19	71.2	10.91	-131.30	0.018	-85.27	0.25	-156.30
2.5	0.13	25.7	11.51	178.00	0.018	-138.30	0.19	148.70
3.0	0.08	-11.0	11.88	127.60	0.017	175.00	0.17	102.60
3.5	0.05	-27.3	11.83	78.99	0.016	129.50	0.17	65.33
4.0	0.06	-41.8	11.93	31.65	0.014	84.32	0.17	29.09
4.5	0.07	-82.0	11.89	-16.77	0.013	40.10	0.18	-12.11
5.0	0.07	-145.3	11.31	-64.18	0.013	-5.37	0.18	-52.05
5.5	0.06	131.8	10.74	-111.10	0.012	-55.78	0.17	-90.80
6.0	0.07	56.8	10.14	-157.80	0.011	-104.80	0.17	-135.70
6.5	0.10	-6.0	9.38	157.10	0.010	-147.40	0.17	175.70
7.0	0.13	-61.6	8.76	113.00	0.010	166.90	0.17	127.50
7.5	0.13	-123.2	8.07	68.80	0.010	122.90	0.19	82.03
8.0	0.16	168.8	7.53	26.25	0.009	80.10	0.21	39.85
8.5	0.23	104.8	7.09	-17.00	0.009	39.33	0.21	0.17
9.0	0.32	48.0	6.61	-60.04	0.007	3.40	0.23	-35.98
9.5	0.41	-1.4	6.33	-104.30	0.008	-33.67	0.21	-84.15
10.0	0.47	-46.7	5.84	-147.80	0.007	-72.67	0.17	-139.60

Absolute Maximum Ratings (*):

SYMBOL	PARAMETER	UNITS	ABSOLUTE MAXIMUM
V _{ds}	Drain-Source Voltage	V	8.0
I _{ds}	Drain Current	mA	150
P _{in max}	RF Input Power	dBm	+12
T _{oper}	Operating Temperature	°C	-40 to +85
T _{ch}	Channel Temperature	°C	175
T _{stg}	Storage Temperature	°C	-60 to 150

(*) Operation of this device above any one of these parameters may cause permanent damage.

MMA-011015-C3

1 - 10 GHz Fully Matched Driver Amplifier

Package Pin-out:

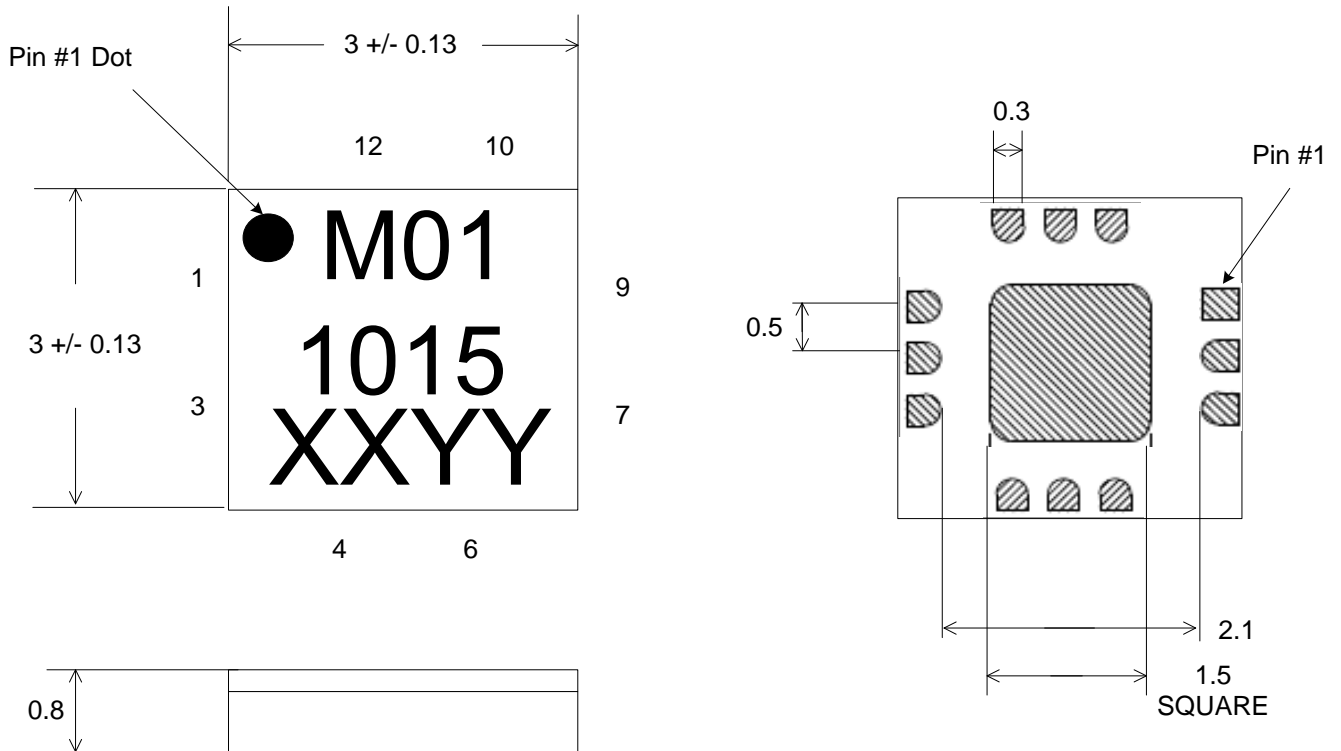

Pin	Description
2	RF Input
8	RF Output
10	Vd
1, 3, 7, 9, 13 (center pad)	Ground
4, 5, 6, 11, 12	N/C

MMA-011015-C3

1 - 10 GHz Fully Matched Driver Amplifier

Application Circuit:

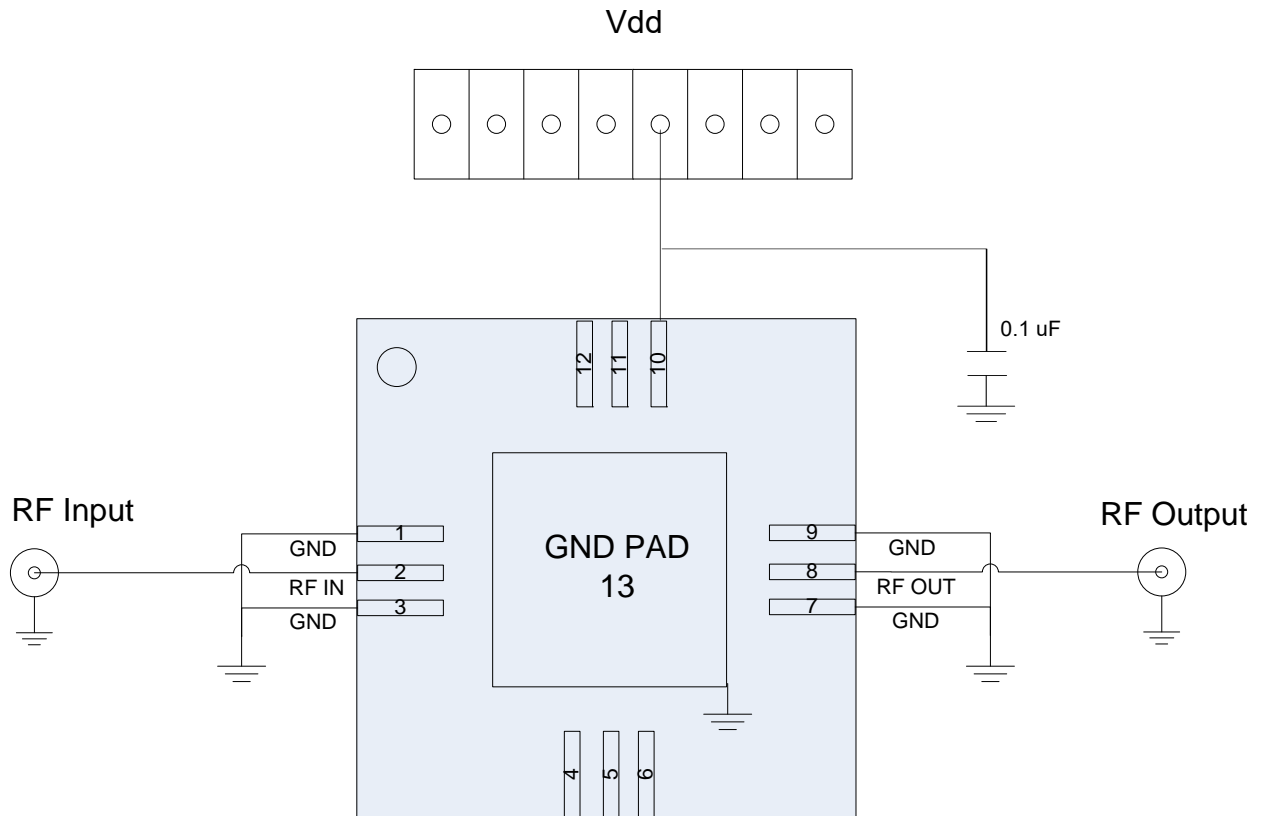

MMA-011015-C3

1 - 10 GHz Fully Matched Driver Amplifier

Contact Information

For additional information please visit www.cmlmicro.com or contact a sales office.



Europe	America	Asia
<ul style="list-style-type: none">• Maldon, UK• Tel +44 (0) 1621 875500• sales@cmlmicro.com	<ul style="list-style-type: none">• Winston-Salem, NC• Tel +1 336 744 5050• us.sales@cmlmicro.com	<ul style="list-style-type: none">• Singapore• Tel +65 6288129• sg.sales@cmlmicro.com

Although the information contained in this document is believed to be accurate, no responsibility is assumed by CML for its use. The product and product information is subject to change at any time without notice. CML has a policy of testing every product shipped using calibrated test equipment to ensure compliance with product specification.

© 2019 CML Microsystems Plc

Looking for pricing, stock, or lifecycle information?

Click below to explore more details on WIN SOURCE:

-  [View MMA-011015-C3 on WIN SOURCE](#)
-  [CML Microcircuits Information](#)

Optimize Your Supply Chain with WIN SOURCE Solutions

-  Global Sourcing Solution
-  Obsolete Management
-  Cost Control Management
-  Shortage Management
-  Alternative Solution
-  Excess Inventory Management