



**THE DATASHEET OF
ICS93V855AGLFT**





DDR Phase Lock Loop Clock Driver

Recommended Application:

DDR Clock Driver

- Low skew, low jitter PLL clock driver
- External feedback pins for input to output synchronization
- Spread Spectrum tolerant inputs
- With bypass mode mux
- Operating frequency 60 to 170 MHz
- Operating Temperature -45°C to +85°C
- CYCLE - CYCLE jitter: <75ps
- OUTPUT - OUTPUT skew: <60ps
- Output Rise and Fall Time: 650ps - 950ps

Pin Configuration

GND	1	ICS93V855I	28	DDRC4
DDRC0	2		27	DDRT4
DDRT0	3		26	VDD2.5
VDD2.5	4		25	GND
CLK_INT	5		24	FB_OUTC
CLK_INC	6		23	FB_OUTT
AVDD2.5	7		22	VDD2.5
AGND	8		21	FB_INT
GND	9		20	FB_INC
DDRC1	10		19	GND
DDRT1	11		18	VDD2.5
VDD2.5	12		17	DDRT3
DDRT2	13		16	DDRC3
DDRC2	14		15	GND

28-Pin 4.4mm TSSOP

Block Diagram

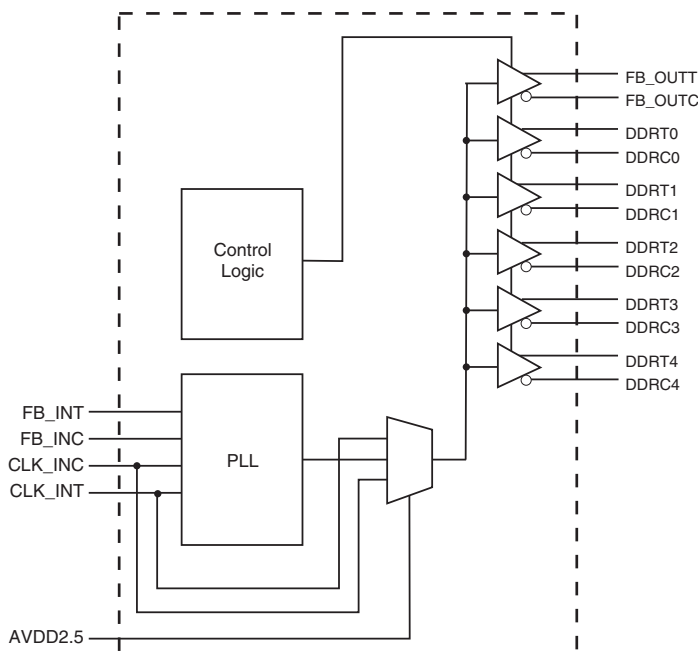

Functionality

AVDD	INPUTS		OUTPUTS				PLL State
	CLK_INT	CLK_INC	DDRT	DDRC	FB_OUTT	FB_OUTC	
GND	L	H	L	H	L	H	Bypassed/Off
GND	H	L	H	L	H	L	Bypassed/Off
2.5V (nom)	L	H	L	H	L	H	On
2.5V (nom)	H	L	H	L	H	L	On
2.5V (nom)	<20 MHz	<20 MHz	Hi-Z	Hi-Z	Hi-Z	Hi-Z	Off

ICS93V855I

Pin Descriptions

PIN #	PIN NAME	PIN TYPE	DESCRIPTION
1	GND	PWR	Ground pin.
2	DDRC0	OUT	"Complimentary" Clock of differential pair output.
3	DDRT0	OUT	"True" Clock of differential pair output.
4	VDD2.5	PWR	Power supply, nominal 2.5V
5	CLK_INT	IN	"True" reference clock input.
6	CLK_INC	IN	"Complimentary" reference clock input.
7	AVDD2.5	PWR	2.5V Analog Power pin for Core PLL
8	AGND	PWR	Analog Ground pin for Core PLL
9	GND	PWR	Ground pin.
10	DDRC1	OUT	"Complimentary" Clock of differential pair output.
11	DDRT1	OUT	"True" Clock of differential pair output.
12	VDD2.5	PWR	Power supply, nominal 2.5V
13	DDRT2	OUT	"True" Clock of differential pair output.
14	DDRC2	OUT	"Complimentary" Clock of differential pair output.
15	GND	PWR	Ground pin.
16	DDRC3	OUT	"Complimentary" Clock of differential pair output.
17	DDRT3	OUT	"True" Clock of differential pair output.
18	VDD2.5	PWR	Power supply, nominal 2.5V
19	GND	PWR	Ground pin.
20	FB_INC	IN	Complement single-ended feedback input, provides feedback signal to internal PLL for synchronization with CLK_INT to eliminate phase error.
21	FB_INT	IN	True single-ended feedback input, provides feedback signal to internal PLL for synchronization with CLK_INT to eliminate phase error.
22	VDD2.5	PWR	Power supply, nominal 2.5V
23	FB_OUTT	OUT	True single-ended feedback output, dedicated external feedback. It switches at the same frequency as other DDR outputs, This output must be connect to FB_INT.
24	FB_OUTC	OUT	Complement single-ended feedback output, dedicated external feedback. It switches at the same frequency as other DDR outputs, This output must be connect to FB_INC.
25	GND	PWR	Ground pin.
26	VDD2.5	PWR	Power supply, nominal 2.5V
27	DDRT4	OUT	"True" Clock of differential pair output.
28	DDRC4	OUT	"Complimentary" Clock of differential pair output.



Absolute Maximum Ratings

- Supply Voltage: (VDD & AVDD) -0.5V to 3.6V
- (VDDI) -0.5V to 4.6V
- Logic Inputs: VI $V_{SS} - 0.5\text{ V}$ to $V_{DD} + 0.5\text{ V}$
- Logic Outputs: VO $V_{SS} - 0.5\text{ V}$ to $V_{DD} + 0.5\text{ V}$
- Input clamp current: I_{IK} (VI < 0 or VI > VDD) +/- 50mA
- Output clamp current: I_{OK} (VO < 0 or VO > VDD) +/- 50mA
- Continuous output current: IO (VO = 0 to VDD) +/- 50mA
- Storage Temperature -65°C to +150°C

Stresses above those listed under *Absolute Maximum Ratings* may cause permanent damage to the device. These ratings are stress specifications only and functional operation of the device at these or any other conditions above those listed in the operational sections of the specifications is not implied. Exposure to absolute maximum rating conditions for extended periods may affect product reliability.

Electrical Characteristics - Input/Supply/Common Output Parameters

TA = -45°C to +85°C; Supply Voltage AVDD, VDD = 2.5 V +/- 0.2V (unless otherwise stated)

PARAMETER	SYMBOL	CONDITIONS	MIN	TYP	MAX	UNITS
Input High Current	I _{IH}	V _I = V _{DD} or GND	5			μA
Input Low Current	I _{IL}	V _I = V _{DD} or GND			5	μA
Operating Supply Current	I _{DD2.5}	C _L = 0pf, R _L = 120 ohms			250	mA
	I _{DDPD}	C _L = 0pf, R _L = 120 ohms			100	μA
Output High Current	I _{OH}	V _{DD} = 2.3V, V _{OUT} = 1V	-18			mA
Output Low Current	I _{OL}	V _{DD} = 2.3V, V _{OUT} = 1.2V	26			mA
High Impedance Output Current	I _{OZ}	V _{DD} =2.7V, V _{out} =V _{DD} or GND			±10	μA
Input Clamp Voltage	V _{IK}	I _{in} = -18mA			-1.2	V
High-level output voltage	V _{OH}	V _{DD} = min to max, I _{OH} = -1 mA	V _{DD} - 0.1			V
		V _{DD} = 2.3V, I _{OH} = -12 mA	1.7			V
Low-level output voltage	V _{OL}	V _{DD} = min to max I _{OL} =1 mA			0.1	
		V _{DD} = 2.3V I _{OH} =12 mA			0.6	V
Input Capacitance ¹	C _{IN}	V _I = V _{DD} or GND		3		pF
Output Capacitance ¹	C _{OUT}	V _I = V _{DD} or GND		3		pF

¹Guaranteed by design and characterization, not 100% tested in production.



DC Electrical Characteristics

$T_A = -45^{\circ}\text{C}$ to $+85^{\circ}\text{C}$; Supply Voltage AVDD, VDD = 2.5 V +/- 0.2V (unless otherwise stated)

PARAMETER	SYMBOL	CONDITIONS	MIN	TYP	MAX	UNITS
Supply Voltage	V_{DDQ}, A_{VDD}		2.3	2.5	2.7	V
Low level input voltage	V_{IL}	CLK_INT, CLK_INC, FB_INC, FB_INT		0.4	$V_{DD}/2 - 0.18$	V
High level input voltage	V_{IH}	CLK_INT, CLK_INC, FB_INC, FB_INT	$V_{DD}/2 + 0.18$	2.1		V
DC input signal voltage (note 2)	V_{IN}		-0.3		$V_{DD} + 0.3$	V
Differential input signal voltage (note 3)	V_{ID}	DC - CLK_INT, CLK_INC, FB_INC, FB_INT	0.36		$V_{DD} + 0.6$	V
		AC - CLK_INT, CLK_INC, FB_INC, FB_INT	0.7		$V_{DD} + 0.6$	V
Output differential cross-voltage (note 4)	V_{OX}		$V_{DD}/2 - 0.15$		$V_{DD}/2 + 0.15$	V
Input differential cross-voltage (note 4)	V_{IX}		$V_{DD}/2 - 0.2$	$V_{DD}/2$	$V_{DD}/2 + 0.2$	V
Operating free-air temperature	T_A		-45		85	$^{\circ}\text{C}$

Notes:

- 1 Unused inputs must be held high or low to prevent them from floating.
- 2 DC input signal voltage specifies the allowable DC excursion of differential input.
- 3 Differential inputs signal voltages specifies the differential voltage [VT-VCP] required for switching, where VTR is the true input level and VCP is the complementary input level.
- 4 Differential cross-point voltage is expected to track variations of VDD and is the voltage at which the differential signal must be crossing.



Switching Characteristics

T_A = -45°C to +85°C; Supply Voltage AVDD, VDD = 2.5 V +/- 0.2V (unless otherwise stated)

PARAMETER	SYMBOL	CONDITION	MIN	TYP	MAX	UNITS
Max clock frequency ³	freq _{op}		33		233	MHz
Application Frequency Range ³	freq _{App}		60		170	MHz
Input clock duty cycle	d _{in}		40		60	%
Output clock slew rate	t _{sl(o)}		1		2	v/ns
CLK stabilization	T _{STAB}				100	µs
Low-to-high level propagation delay time	t _{PLH} ¹	CLK_IN to any output		5.5		ns
High-to-low level propagation delay time	t _{PHL} ¹	CLK_IN to any output		5.5		ns
Output enable time	t _{en}	PD# to any output		5		ns
Output disable time	t _{dis}	PD# to any output		5		ns
Period jitter	t _{jit (per)}	Over the application frequency range	-75		75	ps
Half-period jitter	t _{jit(hper)}		-100		100	ps
Input clock slew rate	t _{sl(l)}		1		2	v/ns
Cycle to Cycle Jitter	t _{cyc} -t _{cyc}		-75		75	ps
Phase error ⁴	t _(phase error)		-50		50	ps
Output to Output Skew	t _{skew}			40	60	ps
Rise Time, Fall Time	t _r , t _f		Load = 120φ/16pF	650	800	950

Notes:

1. Refers to transition on noninverting output in PLL bypass mode.
2. While the pulse skew is almost constant over frequency, the duty cycle error increases at higher frequencies. This is due to the formula: duty cycle=twH/tc, were the cycle (tc) decreases as the frequency goes up.
3. Switching characteristics are guaranteed for application frequency range. The PLL Locks over the Max Clock Frequency range, but the device do not necessarily meet other timing parameters.
4. Does not include jitter.

Parameter Measurement Information

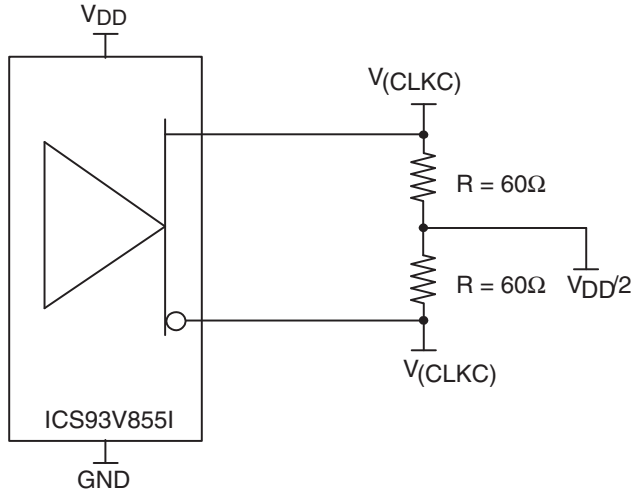
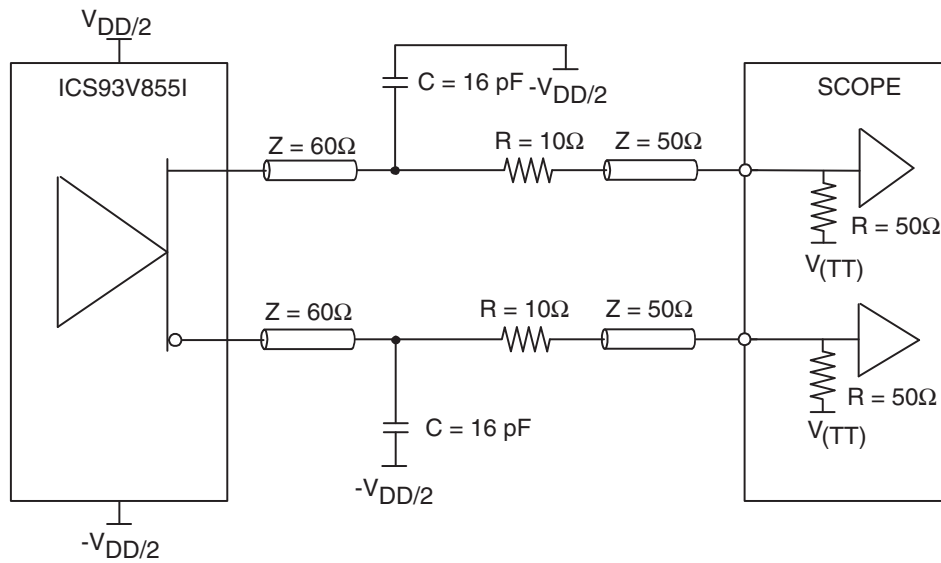

Figure 1. IBIS Model Output Load



NOTE: $V_{(TT)} = \text{GND}$

Figure 2. Output Load Test Circuit

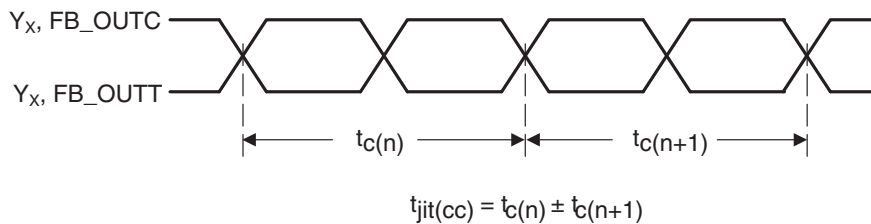

Figure 3. Cycle-to-Cycle Jitter

Parameter Measurement Information

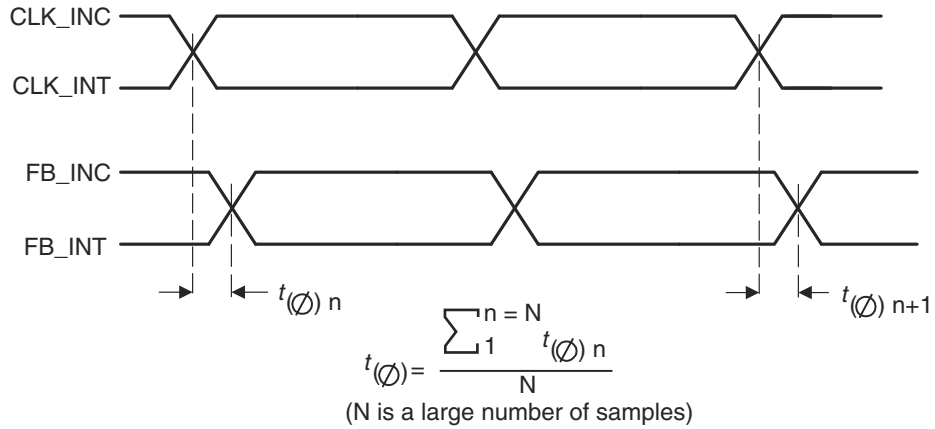

Figure 4. Static Phase Offset

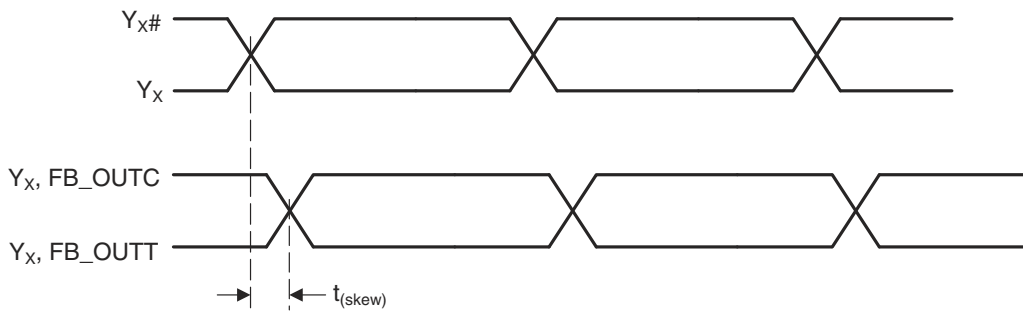

Figure 5. Output Skew

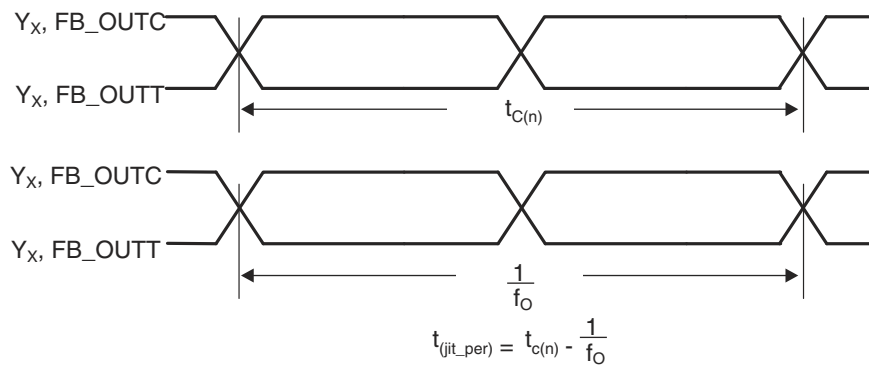

Figure 6. Period Jitter



Parameter Measurement Information

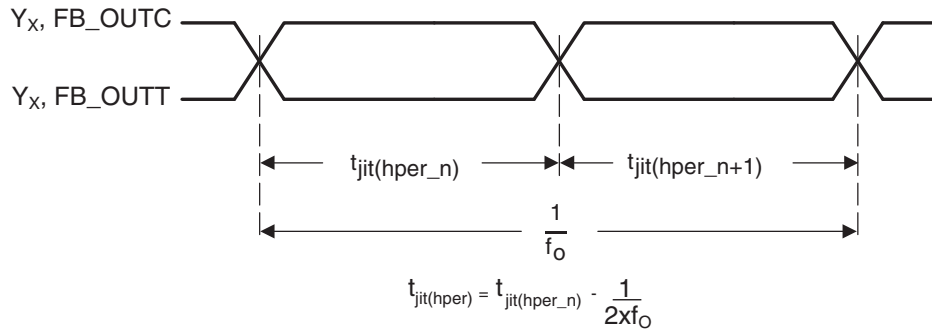

Figure 7. Half-Period Jitter

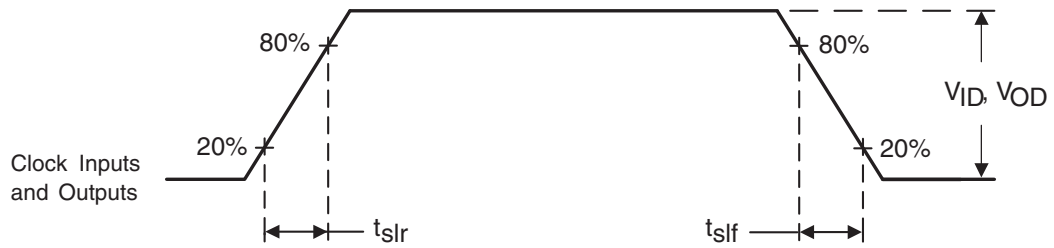
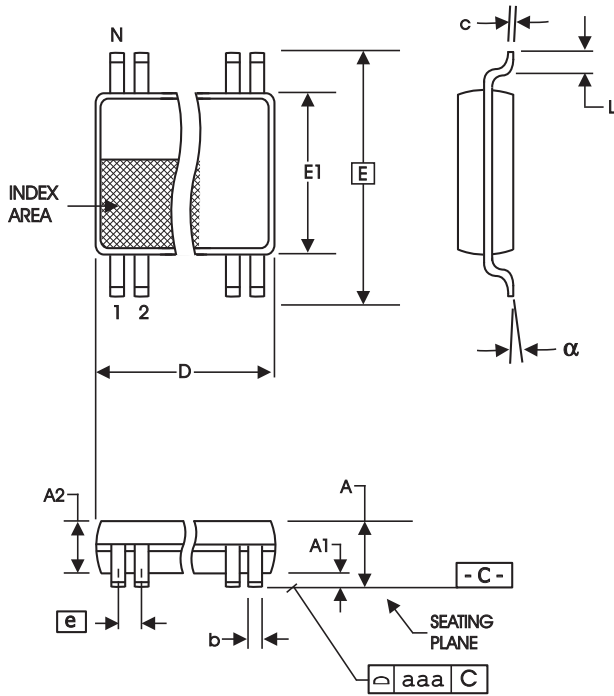

Figure 8. Input and Output Slew Rates



SYMBOL	In Millimeters		In Inches	
	COMMON DIMENSIONS	COMMON DIMENSIONS	COMMON DIMENSIONS	COMMON DIMENSIONS
	MIN	MAX	MIN	MAX
A	--	1.20	--	.047
A1	0.05	0.15	.002	.006
A2	0.80	1.05	.032	.041
b	0.19	0.30	.007	.012
c	0.09	0.20	.0035	.008
D	SEE VARIATIONS		SEE VARIATIONS	
E	6.40 BASIC		0.252 BASIC	
E1	4.30	4.50	.169	.177
e	0.65 BASIC		0.0256 BASIC	
L	0.45	0.75	.018	.030
N	SEE VARIATIONS		SEE VARIATIONS	
a	0°	8°	0°	8°
aaa	--	0.10	--	.004

VARIATIONS

N	D mm.		D (inch)	
	MIN	MAX	MIN	MAX
28	9.60	9.80	.378	.386

Reference Doc.: JEDEC Publication 95, MO-153
10-0035

4.40 mm. Body, 0.65 mm. pitch TSSOP
(173 mil) (0.0256 Inch)

Ordering Information

93V855yGILF-T

Example:

XXXX y G LF-T

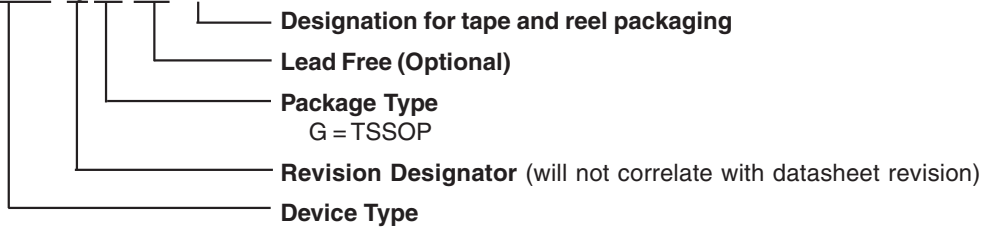

Looking for pricing, stock, or lifecycle information?

Click below to explore more details on WIN SOURCE:

- [⊖ View ICS93V855AGLFT on WIN SOURCE](#)
- [⊖ IDT, Integrated Device Technology Inc Information](#)

Optimize Your Supply Chain with WIN SOURCE Solutions

- ✓ Global Sourcing Solution
- ✓ Obsolete Management
- ✓ Cost Control Management
- ✓ Shortage Management
- ✓ Alternative Solution
- ✓ Excess Inventory Management