



COAXIAL

Low Noise Amplifier

ZX60-10223G+

Mini-Circuits

50Ω 10 to 20 GHz SMA Female

KEY FEATURES

- Wideband, 10 to 20 GHz
- High gain, 26 dB typ.
- Low noise figure, 2.3 dB typ.
- Voltage regulated internally and reverse voltage protected
- Excellent directivity, 22 dB typ.



Generic photo used for illustration purposes only

APPLICATIONS

- Microwave point to point radios
- Military EW and radar
- Satellite Systems

FUNCTIONAL DIAGRAM

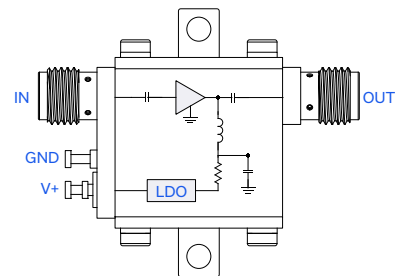

PRODUCT OVERVIEW

Mini-Circuits' ZX60-10223G+ is a wideband low noise connectorized amplifier providing a unique combination of low noise figure and high gain over a very wide frequency range, supporting a wide range of applications and many systems where high performance over wideband is needed. This design operates on a single +5V supply and comes in a rugged, compact unibody case (0.74 x 0.75 x 0.46") with SMA connectors, making it an excellent candidate for tough operating conditions and crowded system layouts.

ELECTRICAL SPECIFICATIONS AT +25°C

Parameter	Frequency (GHz)	Min.	Typ.	Max.	Units
Frequency Range		10		20	GHz
Noise Figure	10-12	—	2.2	—	dB
	12-18	—	2.3	—	
	18-20	—	2.6	—	
Gain	10-12	21	26	—	dB
	12-18	22	26	—	
	18-20	20	24	—	
Input Return Loss	10-12	—	10	—	dB
	12-18	—	8	—	
	18-20	—	10	—	
Output Return Loss	10-12	—	15	—	dB
	12-18	—	9	—	
	18-20	—	6	—	
Output Power at 1 dB Compression (P1dB) ¹	10-12	—	+9	—	dBm
	12-18	—	+10	—	
	18-20	—	+10	—	
Output Third Order Intercept Point (OIP3) ²	10-12	—	+18	—	dBm
	12-18	—	+20	—	
	18-20	—	+20	—	
Device Operating Voltage (V _{DD})	—	+4.75	+5.0	+8.0	V
Device Operating Current (I _{DD})	—	—	75	120	mA

1. Current increases at P1dB

2. OIP3 measured with 0 dBm tones and 1 MHz spacing.





COAXIAL

Low Noise Amplifier

ZX60-10223G+

Mini-Circuits

50Ω 10 to 20 GHz SMA Female

TYPICAL PERFORMANCE GRAPHS

GAIN

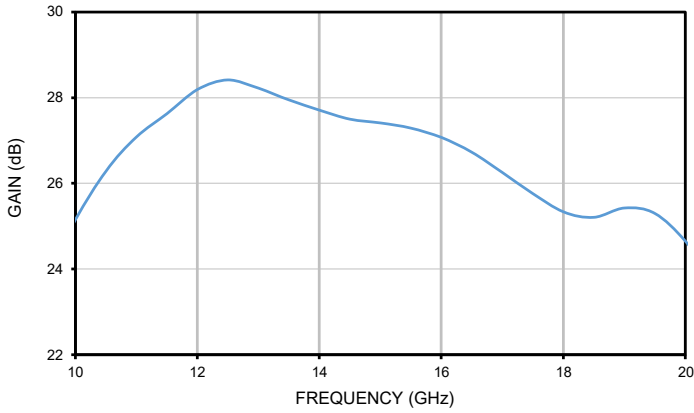

DIRECTIVITY

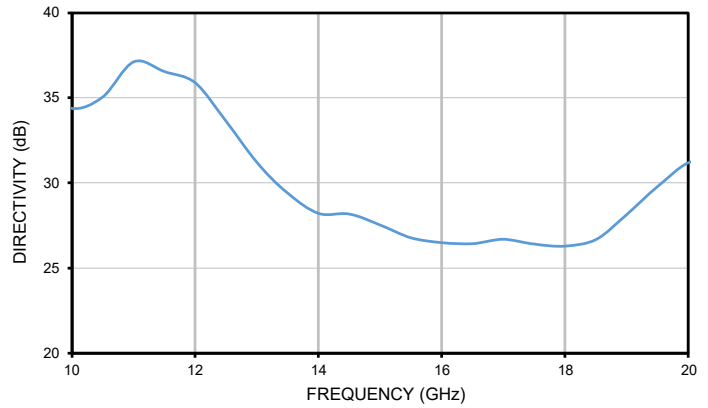

RETURN LOSS

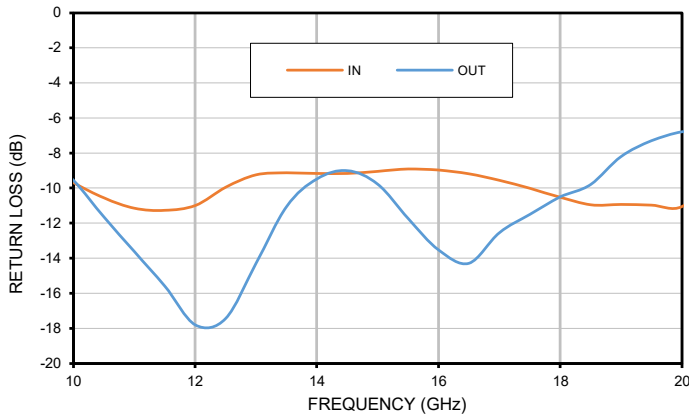

OUTPUT POWER AT 1dB COMPRESSION

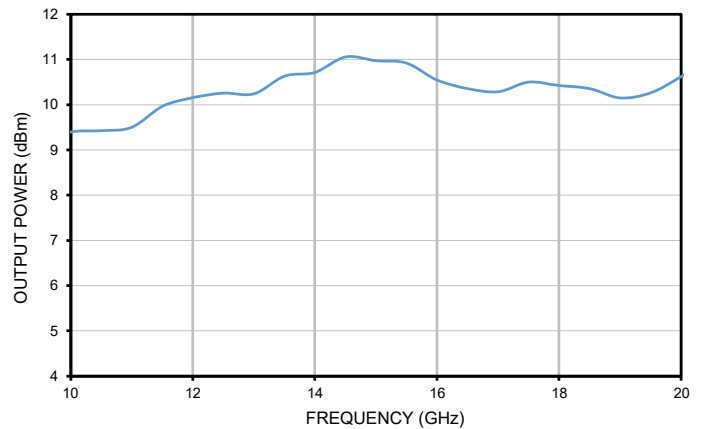

NOISE FIGURE

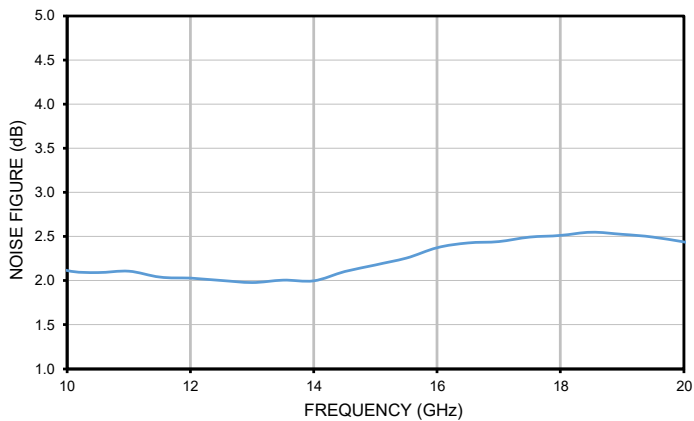

OUTPUT IP3

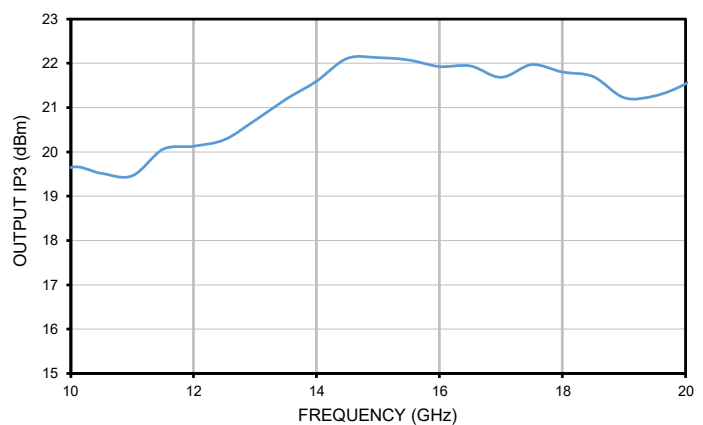



COAXIAL

Low Noise Amplifier

ZX60-10223G+

Mini-Circuits

50Ω 10 to 20 GHz SMA Female

ABSOLUTE MAXIMUM RATINGS

Parameter	Ratings
Operating Temperature (ground lead)	-40°C to +85°C
Storage Temperature	-55°C to +100°C
Total Power Dissipation	1 W
Input Power (CW), Vd=5V	+13 dBm
DC Voltage	+8.5 V

Permanent damage may occur if any of these limits are exceeded.

DETERMINING MAXIMUM THERMAL RESISTANCE OF USERS' EXTERNAL HEAT SINK

$\text{MAXIMUM THERMAL RESISTANCE} = \frac{\text{MAXIMUM OPERATING CASE TEMP} - \text{MAXIMUM USER AMBIENT TEMP}}{\text{POWER DISSIPATION}}$	
Example:	MAXIMUM OPERATING CASE TEMP = +50 °C (CHECK MAXIMUM RATINGS TABLE FOR THIS VALUE) MAXIMUM USER AMBIENT TEMP = +30 °C (USER DEFINED) POWER DISSIPATION = 10 WATTS (CHECK MAXIMUM RATINGS TABLE FOR THIS VALUE) THEN MAXIMUM ALLOWABLE THERMAL RESISTANCE = 2 °C/W



COAXIAL

Low Noise Amplifier

ZX60-10223G+

Mini-Circuits

50Ω 10 to 20 GHz SMA Female

CASE STYLE DRAWING

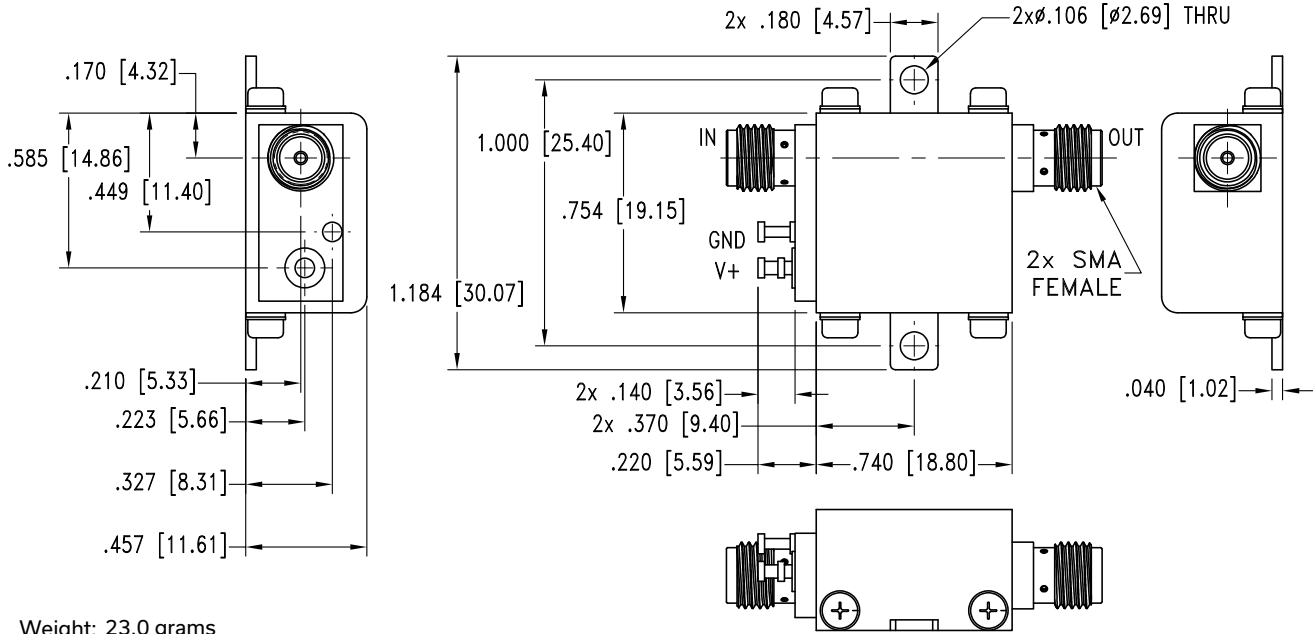

Weight: 23.0 grams

Dimensions are in inches [mm]. Tolerances: 2 Pl. ±.03; 3 Pl. ±.015 Inches

⚠ NOTE: When soldering the DC connections, caution must be used to avoid overheating the DC terminal. See Application Note [AN-40-010](#)



COAXIAL

Low Noise Amplifier

ZX60-10223G+

Mini-Circuits

50Ω 10 to 20 GHz SMA Female

ADDITIONAL INFORMATION IS AVAILABLE ON OUR DASHBOARD.

Performance Data & Graphs	Data Graphs S-Parameter (S2P Files) Data Set (.zip file)
RoHS Status	Compliant
Environmental Ratings	ENV23T10

ORDERING INFORMATION

Model No. Link	ZX60-10223G+
Case Style	GC957-2
Connector	IN SMA/Female / OUT SMA/Female







Looking for pricing, stock, or lifecycle information?

Click below to explore more details on WIN SOURCE:

 [View ZX60-10223G+ on WIN SOURCE](#)

 [Mini-Circuits Information](#)

Optimize Your Supply Chain with WIN SOURCE Solutions

-  Global Sourcing Solution
-  Obsolete Management
-  Cost Control Management
-  Shortage Management
-  Alternative Solution
-  Excess Inventory Management