

D SUBMINIATURE JK SERIES

Crimp style plug and socket

CRIMP STYLE PLUG AND SOCKET

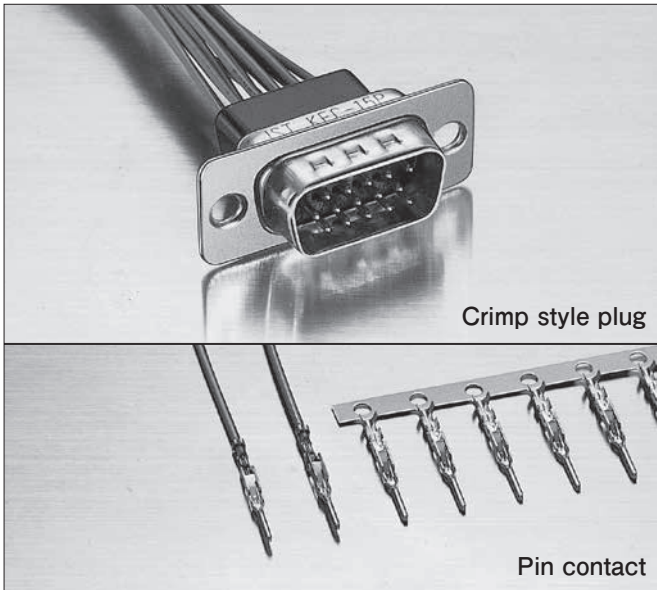

Crimp style plug

Pin contact

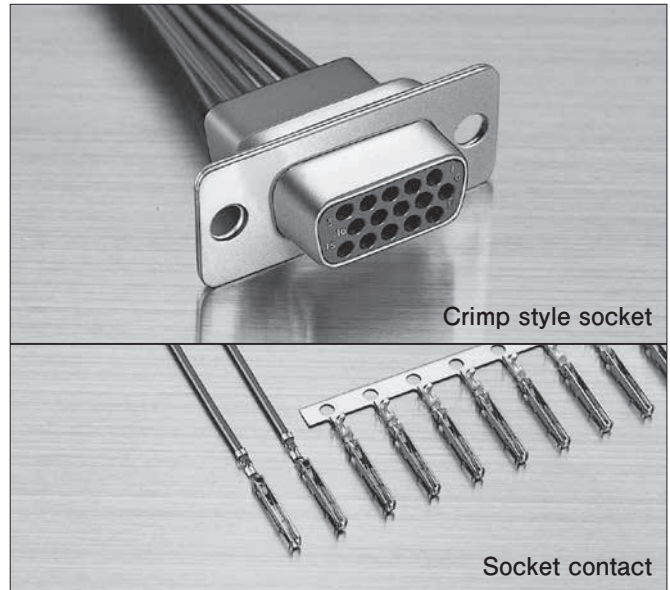

Crimp style socket

Socket contact

Features

- The dimples in the shell provide the ground connection and are an important factor in preventing electromagnetic interference.

- The contact has a retention lance that makes assembly to the housing smooth and secure.

Standards

Recognized E60389 Certified LR20812

- Please refer to the "Handling Precautions for Terminals and Connectors" on our website (listed in the "Technical Documents" column on the Product Information page) before use.

- Contact JST for details.

- RoHS2 compliance

Specifications

Materials

Connector	Part name	Material and Finish
Plug	Contact	Brass, nickel-undercoated, Mating part: gold-plated Crimping part: tin-plated (reflow treatment)
	Insulator	Glass-filled PBT, UL94V-0, black
	Shell	Steel, copper-undercoated, nickel-plated
Socket	Contact	Phosphor bronze, Nickel-undercoated, Mating part: gold-plated Crimping part: tin-plated (reflow treatment)
	Insulator	Glass-filled PBT, UL94V-0, black
	Shell	Steel, copper-undercoated, nickel-plated

Model number identification

Contact JK - S P 2 1 40

- Series name
- Product shape: S ... Chain
- Type of contact: P ... Pin contact, S ... Socket contact
- Applicable wire: 2 ... AWG #28 to #24
- Material: 1 ... Brass (Pin contact), 3 ... Phosphor bronze (Socket contact)
- Surface finish of mating part:
40 ... Gold-plated (flash) 44 ... 0.76 micron gold-plated

Note: Contact JST for special plating requirements.

Housing K - E C - 15 P - 3

- Series name
- Shell size: E
- Wire connection style: C ... crimp style
- Number of circuits: 15
- Connector style: P ... Plug, S ... Socket
- Plating specification of shell: 3 ... Copper-undercoated, nickel-plated

Characteristics

Current rating	1.0 A AC/DC (AWG #24)
Voltage rating	250 V AC/DC
Temperature range	-40°C to +85°C (including temperature rise in applying electrical current)
Contact resistance	Initial value/ 15 mΩ max. After environmental tests/ 30 mΩ max.
Insulation resistance	5,000 MΩ min.
Withstanding voltage	1,000 VAC/minute

Note: Contact JST for details.

D SUBMINIATURE CONNECTOR JK SERIES

Pin contact (for plug housing)

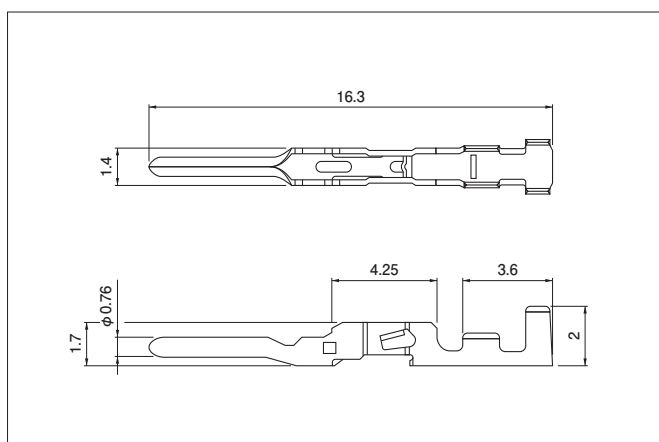

Socket contact (for socket housing)

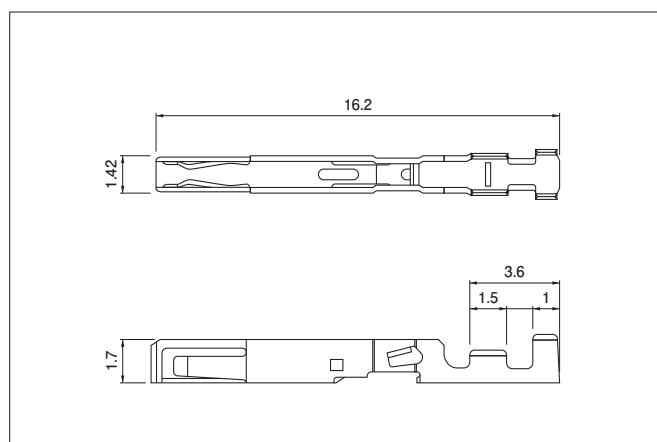

Model No.		Surface finish of mating part	Applicable wire		Q'ty/box
Pin contact	Socket contact		AWG #	Insulation O.D. (mm)	
JK-SP2140	JK-SS2340	Gold-plated (flash)	28 to 24	0.9 to 1.4	10,000
JK-SP2144	JK-SS2344	Gold-plated (0.76 micron)			

RoHS2 compliance This product displays (LF)(SN) on a label.

Plug housing

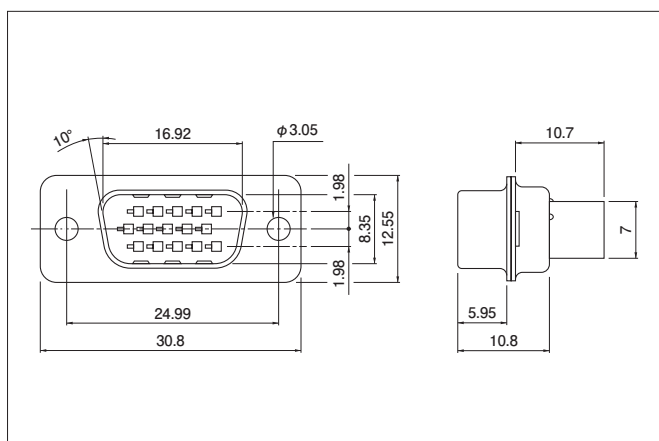

No. of circuits	Model No.	Q'ty/box
15	KEC-15P-3	100

RoHS2 compliance

Receptacle housing

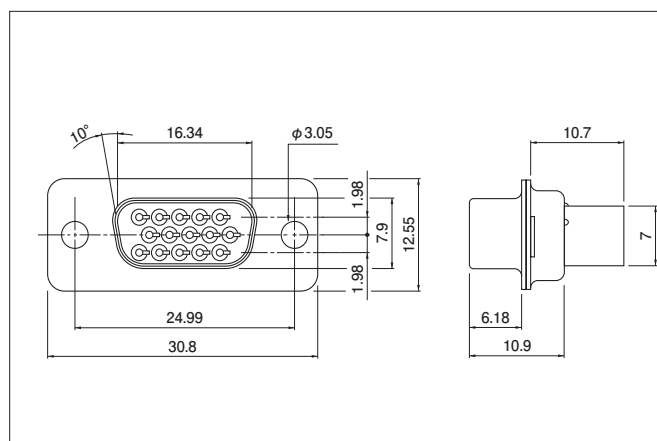

No. of circuits	Model No.	Q'ty/box
15	KEC-15S-3	100

RoHS2 compliance

Crimping machine, Applicator

Contact	Crimping machine	Applicator	Crimp applicator with dies
J-SP2***	AP-K2N	MKS-L	APLMK J-SP/SS2
J-SS2***			APLMK J-SP/SS2

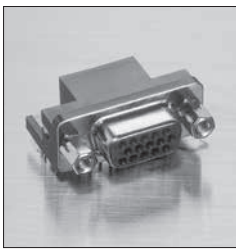

D SUBMINIATURE JK SERIES CONNECTOR

Right angle through-hole plug and socket

RIGHT ANGLE THROUGH-HOLE SOCKET

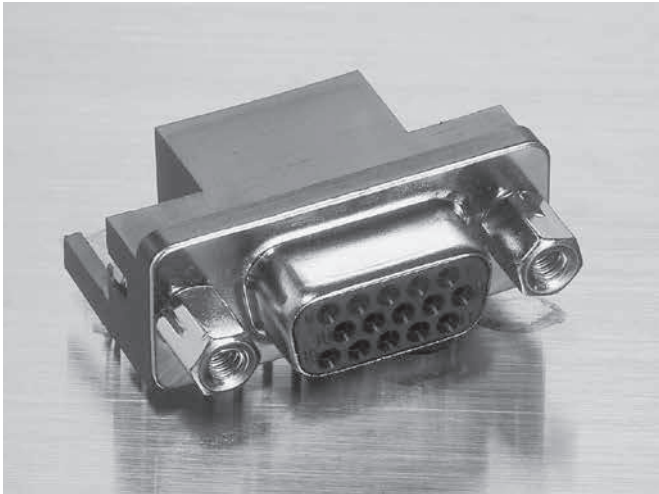

(with hexagonal lock screw blocks)

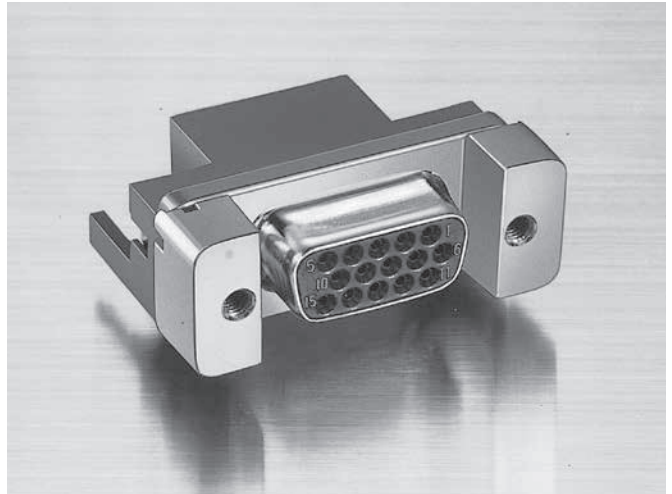

(with rectangular lock screw blocks)

Features

- The mating section of the contact has a twin-contact style construction with uniform elasticity to ensure a reliable contact even when repeatedly mated and unmated.
- A wide variety of grounding adapters are available so that the receptacle can be grounded to the circuitry of a printed circuit board to prevent electromagnetic interference.

Standards

Recognized E60389 Certified LR20812

- * Please refer to the "Handling Precautions for Terminals and Connectors" on our website (listed in the "Technical Documents" column on the Product Information page) before use.
- * Contact JST for details.
- * RoHS2 compliance

Specifications

Materials

Part name	Material and Surface finish, etc.
Contact	Phosphor bronze, nickel-undercoated, Mating part: gold-plated Solder tail: tin-plated (reflow treatment)
Insulator	Glass-filled PBT, UL94V-0, black
Shell	Steel, copper-undercoated, nickel-plated
Grounding adapter having a 3.2 mm dia. hole	Steel, copper-undercoated, nickel-plated
Grounding adapter having an M3 tapped hole	Steel, copper-undercoated, nickel-plated
Grounding adapter having a spring lock device	Brass, nickel-undercoated, tin/copper alloy-plated

Characteristics

Current rating	1.0 A AC/DC (AWG #24)
Voltage rating	250 V AC/DC
Temperature range	-40°C to +85°C (including temperature rise in applying electrical current)
Contact resistance	Initial value/ 15 mΩ max. After environmental tests/ 30 mΩ max.
Insulation resistance	5,000 MΩ min.
Withstanding voltage	1,000 VAC/minute

Note: Contact JST for details.

D SUBMINIATURE CONNECTOR JK SERIES

PC board layout (viewed from component side)

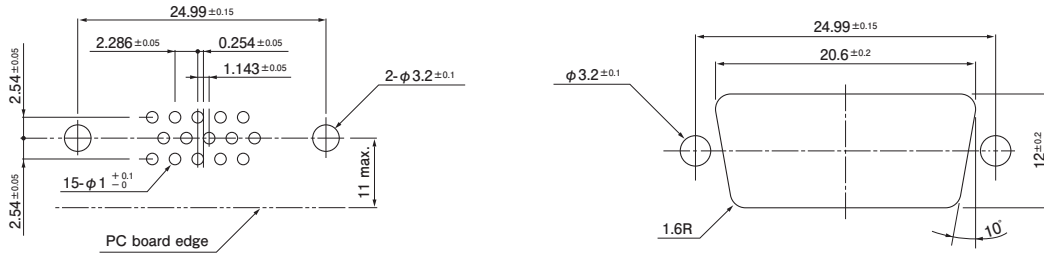

- Note: 1. Tolerances are non-cumulative: ± 0.05 mm for all centers.
 2. Hole dimensions differ according to the type of PC board and piercing method.
 The dimensions above should serve as a guideline. Contact JST for details.

Model number identification







	K	E	Y	-	15	S	-	2A	3	A	14	-	23	
• Series name														
• Shell size: E														
• Wire connection type: Y ... Right angle through-hole style														
• Number of circuits: 15														
• Connector type: S ... Socket														
• Connector construction/Dimensions: Standard of the series														
• Types of grounding adapters														
0 ... Without grounding adapters														
1 ... With grounding adapters having a 3.2 mm dia. hole														
2 ... With grounding adapters having an M3 thread														
3 ... With grounding adapters having a spring lock device (1)														
4 ... With grounding adapters having a spring lock device (2)														
• Types of lock screw blocks														
A ... With hexagonal lock screw blocks having a No. 4-40UNC inch thread														
B ... With hexagonal lock screw blocks having an M2.6 thread														
C ... With rectangular lock screw blocks having an M2.6 thread														
D ... Without lock screw blocks														
E ... Without lock screw blocks, but with grounding adapters having a 3.05 mm dia. hole														
F ... Without lock screw blocks, but with grounding adapters having a No. 4-40UNC inch thread														
G ... Without lock screw blocks, but with grounding adapters having an M2.6 thread														
H ... Without lock screw blocks, but with grounding adapters having an M3 thread														
• Surface finish of mating part														
Blank ... Gold-plated (flash)												14	... 0.76 micron gold-plated	
• Blocked hole for keying: Blank ... all holes open,												23	... #9 hole blocked	

Note: Contact JST for special plating requirements.

D SUBMINIATURE CONNECTOR JK SERIES

Right angle through-hole socket		Type A	Type B										
<p>H: Height of the lock screw block (for Types A, B & C)</p> <table border="1"> <thead> <tr> <th rowspan="2">No. of circuits</th> <th colspan="2">Model No.</th> <th rowspan="2">Q'ty/ box</th> </tr> <tr> <th>Gold-plated (flash) socket</th> <th>Gold-plated (0.76 micron) socket with No.9 hole blocked</th> </tr> </thead> <tbody> <tr> <td>15</td> <td>KEY-15S-2A**</td> <td>KEY-15S-2A**14-23</td> <td>100 (☆)</td> </tr> </tbody> </table> <p>RoHS2 compliance This product displays (LF)(SN) on a label. Note: 1. Please note that there is a discontinued product depending on the combination of accessories. 2. ** shows the location where a two-digit code (see the table below for codes) should be entered. For example, if a 15-circuit gold-plated (flash) socket with hexagonal lock screw blocks having a No. 4-40UNC inch thread and without grounding adapters is required, specify the model number as KEY-15S-2A0A. (☆) Type C...60</p>		No. of circuits	Model No.		Q'ty/ box	Gold-plated (flash) socket	Gold-plated (0.76 micron) socket with No.9 hole blocked	15	KEY-15S-2A**	KEY-15S-2A**14-23	100 (☆)	<p>With hexagonal lock screw blocks (H: 6.3 mm) having a No.4-40UNC inch thread</p>	<p>With hexagonal lock screw blocks (H: 6.3 mm) having an M2.6 thread</p>
No. of circuits	Model No.		Q'ty/ box										
	Gold-plated (flash) socket	Gold-plated (0.76 micron) socket with No.9 hole blocked											
15	KEY-15S-2A**	KEY-15S-2A**14-23	100 (☆)										
Without grounding adapters		0A	0B										
With grounding adapters with a 3.2 mm dia. hole	 	—	1B										
With grounding adapters with an M3 thread	 	2A	2B										
With grounding adapters with a spring lock lever (1)	 	3A	3B										
With grounding adapters with a spring lock device (2)	 	—	—										

D SUBMINIATURE CONNECTOR JK SERIES

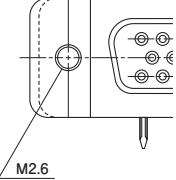
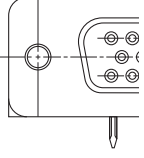
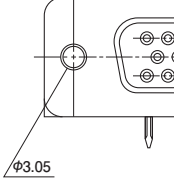
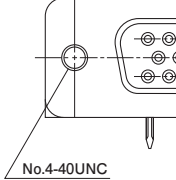
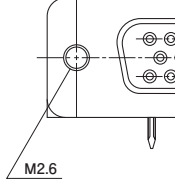
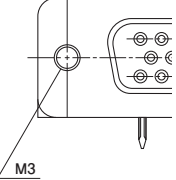
Type C	Type D	Type E	Type F	Type G	Type H
					
With rectangular lock screw blocks (H: 6.2 mm) having an M2.6 thread	Without lock screw blocks	Without lock screw blocks E: Grounding adapter has no thread. F, G, H: Grounding adapters have a thread (*1) for securing separately-purchased lock screw blocks (*2)			
		Used a lock screw block [model number KFS-()S-C1N]	*1: No.4-40UNC inch thread *2: Model number KFS-4S-()1W(M)	*1: M2.6 thread *2: Model number KFS-2.6S-()1W(M)	*1: M3 thread *2: Model number KFS-3S-()1W(M)
					
0C	0D	—	—	—	—
1C	1D	1E	1F	1G	—
2C	2D	2E	2F	—	—
3C	3D	3E	3F	3G	—
—	—	—	—	—	4H

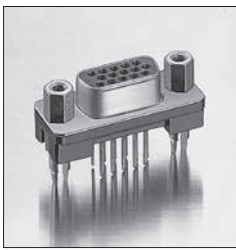

D SUBMINIATURE CONNECTOR JK SERIES

Straight through-hole socket

STRAIGHT THROUGH-HOLE SOCKET

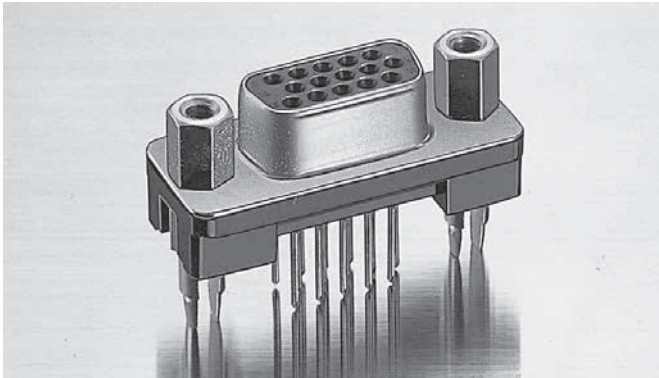

(with hexagonal lock screw blocks)

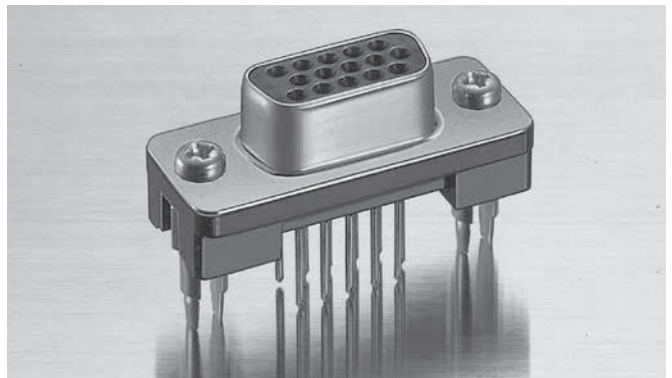

(without lock screw blocks)

Features

- The mating section of the contact has a twin-contact style construction with uniform elasticity to ensure a reliable contact even when repeatedly mated and unmated.

- A grounding adapter with a spring lock device allows the connector to be temporarily secured on the printed circuit board so that the connector can be soldered easily.

Specifications

Materials

Part name	Material and Surface finish, etc.
Contact	Phosphor bronze, nickel-undercoated, Mating part: gold-plated Solder tail: tin-plated (reflow treatment)
Insulator	Glass-filled PBT, UL94V-0, black
Shell	Steel, copper-undercoated, nickel-plated
Grounding adapter	Brass, nickel-undercoated, tin/copper alloy-plated

Characteristics

Current rating	1.0 A AC/DC
Voltage rating	250 V AC/DC
Temperature range	-40°C to +85°C (including temperature rise in applying electrical current)
Contact resistance	Initial value/ 15 mΩ max. After environmental tests/ 30 mΩ max.
Insulation resistance	5,000 MΩ min.
Withstanding voltage	1,000 VAC/minute
Applicable PC board thickness	1.6 mm

Note: Contact JST for details.

Straight through-hole socket

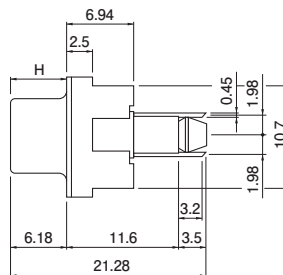
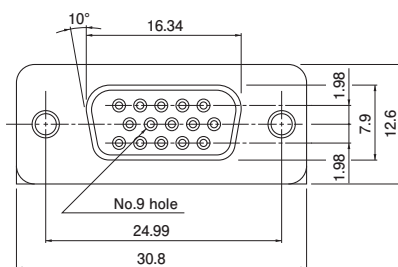

Type A

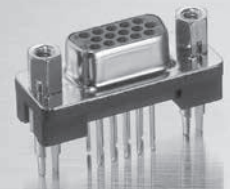

With hexagonal lock screw blocks (H: 6.3 mm) having a No.4-40UNC inch thread

H: Height of the lock screw block (for Types A & B)

No. of circuits	Model No.		Q'ty/box
	Gold-plated (flash) socket	Gold-plated (0.76 micron) socket with No.9 hole blocked	
15	KES-15S-2A**	KES-15S-2A**14-23	100

RoHS2 compliance This product displays (LF)(SN) A on a label.

Note: ** shows the location where a two-digit code (see the table below for codes) should be entered. For example, if a 15-circuits gold-plated (flash) socket with hexagonal lock screw blocks having a No. 4-40UNC inch thread and with grounding adapters having a spring lock device is required, specify the model number as KES-15S-2A3A.

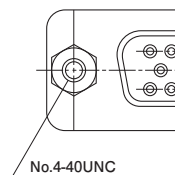

With grounding adapters with a spring lock device

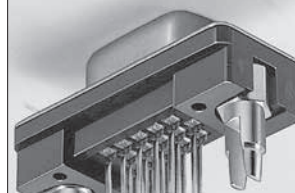

3A

D SUBMINIATURE CONNECTOR JK SERIES

Standards

Recognized E60389  Certified LR20812

- * Please refer to the "Handling Precautions for Terminals and Connectors" on our website (listed in the "Technical Documents" column on the Product Information page) before use.
- * Contact JST for details.
- * RoHS2 compliance

PC board layout (viewed from component side) and Panel layout

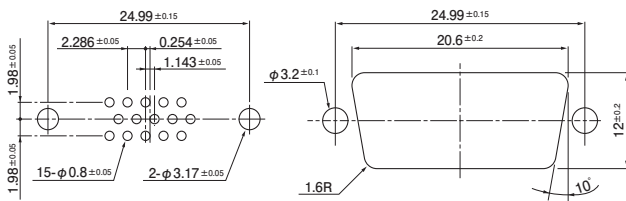

- Note: 1. Tolerances are non-cumulative: ± 0.05 mm for all centers.
 2. Hole dimensions differ according to the type of PC board and piercing method.
 The dimensions above should serve as a guideline. Contact JST for details.

Model number identification

K E S - 15 S - 2A 3 A 14 - 23

- Series name
- Shell size: E
- Wire connection type:
S ... Straight through-hole type
- Number of circuits: 15
- Connector type: S ... Socket
- Connector construction/dimensions:
Standard JK series straight through-hole type
- Type of grounding adapters
3 ... With grounding adapters having a spring lock device
- Type of lock screw blocks
A ... With hexagonal lock screw blocks having a No. 4-40UNC inch thread
B ... With hexagonal lock screw blocks having an M2.6 thread
D ... Without lock screw blocks
F ... Without lock screw blocks, but with grounding adapters having a No. 4-40UNC inch thread
H ... Without lock screw blocks, but with grounding adapters having an M3 thread
- Surface finish of mating part
Blank ... Gold-plated (flash) 14 ... 0.76 micron gold-plated
- Blocked hole for keying: Blank ... all holes open 23 ... #9 hole blocked

Note: Contact JST for special plating requirements.

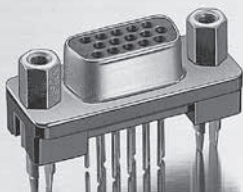
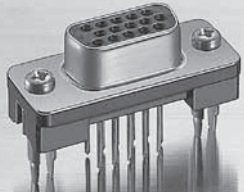
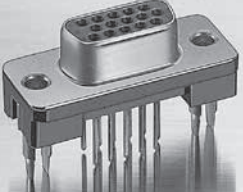
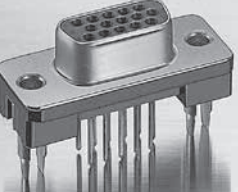
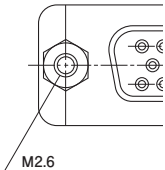
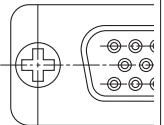
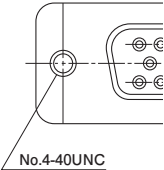
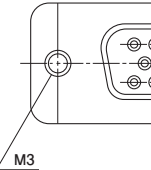
Type B	Type D	Type F	Type H
			
With hexagonal lock screw blocks (H: 6.3 mm) having an M2.6 thread	Without lock screw blocks	Without lock screw blocks F, H: Grounding adapters have a thread (*1) for securing separately-purchased lock screw blocks (*2)	
		*1: No.4-40UNC inch thread *2: Model number JFS-4S-()1W(M) 	*1: M3 thread *2: Model number JFS-3S-()1W(M) 
3B	3D	3F	3H



D SUBMINIATURE CONNECTOR J&JK SERIES

Accessories/EMI prevention shielding cover (J cover)

J COVER



J cover

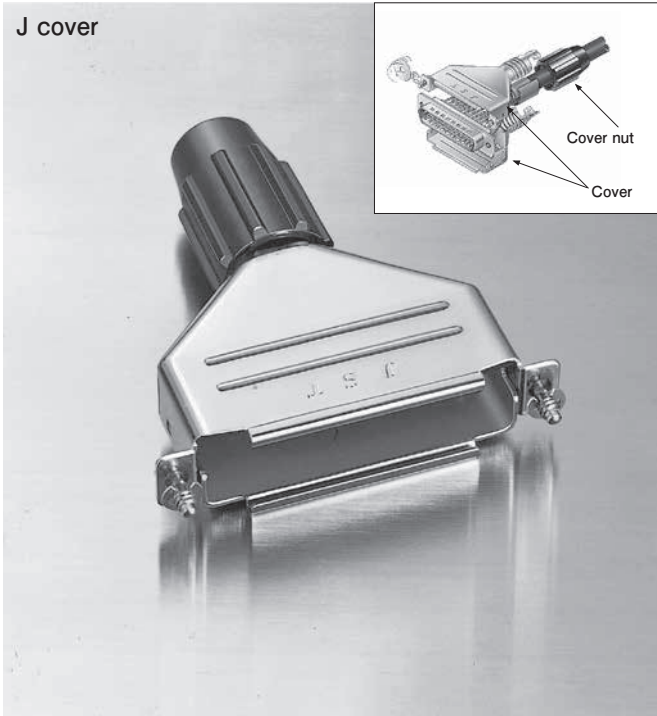

Features

- This shielding cover is made of steel, formed by our advanced stamping technology, and nickel-plated.
 - The box-shaped cover completely encloses such EMI radiating areas as the connections between the connector and wires. The result is a superior shielding effect.
 - To install the shielding cover, simply align and press the upper and lower cover elements, then tighten the nuts. It then securely grips the round cables.
 - This cover is so compact, light and sturdy, that it can be used to cover the connectors of any input/output cable. Moreover, it is attractive in appearance.
- * Please refer to the "Handling Precautions for Terminals and Connectors" on our website (listed in the "Technical Documents" column on the Product Information page) before use.
- * Contact JST for details.
- * RoHS2 compliance

Standards

Recognized E60389

Applicable cable dimensions

No. of circuits	J series	9	15	25	37
	JK series	15	—	—	—
Cable outer diameter (mm)		7.0 ± 0.2		8.0 ± 0.2	10.0 ± 0.2

Shielding cover A

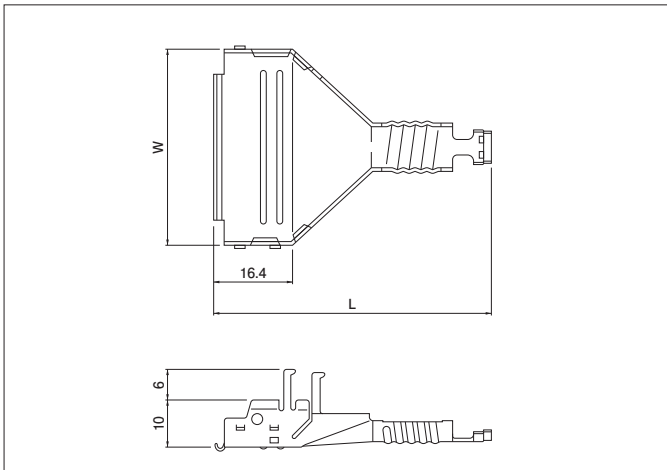

J series		JK series		Dimensions (mm)		Q'ty/box
No. of circuits	Model No.	No. of circuits	Model No.	W	L	
9	J-SC9A	15	JK-SC15A	19.4	42.0	200
15	J-SC15A	—	—	27.6	46.9	150
25	J-SC25A	—	—	41.4	57.0	100
37	J-SC37A	—	—	57.8	70.6	125

Material and Surface finish, etc.

Steel, copper-undercoated, nickel-plated

Shielding cover B

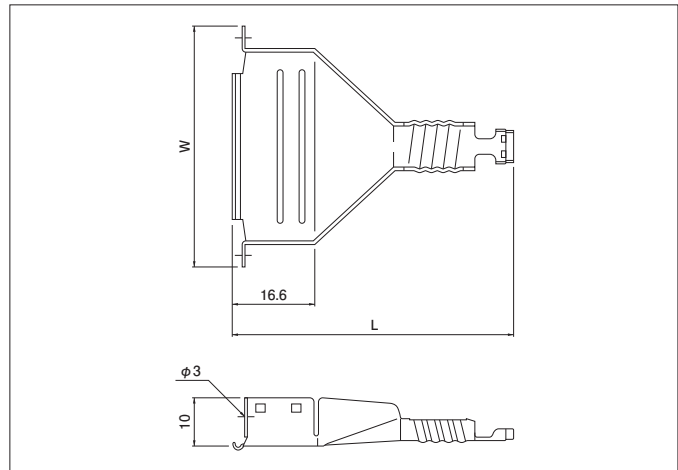

No. of circuits		Model No.	Dimensions (mm)		Q'ty/box
J series	JK series		W	L	
9	15	J-SC9B	30.0	(42.0)	200
15	—	J-SC15B	38.0	(46.9)	150
25	—	J-SC25B	52.0	(57.0)	150
37	—	J-SC37B	68.0	(70.6)	100

Material and Surface finish, etc.

Steel, copper-undercoated, nickel-plated

RoHS2 compliance

Note: The cover of the JK series 15-circuit connector is the same as that of the J series 9-circuit connector, except for the number of circuits indicated.

RoHS2 compliance

Note: The cover of the JK series 15-circuit connector is the same as that of the J series 9-circuit connector.

D SUBMINIATURE CONNECTOR J&JK SERIES

Cover nut

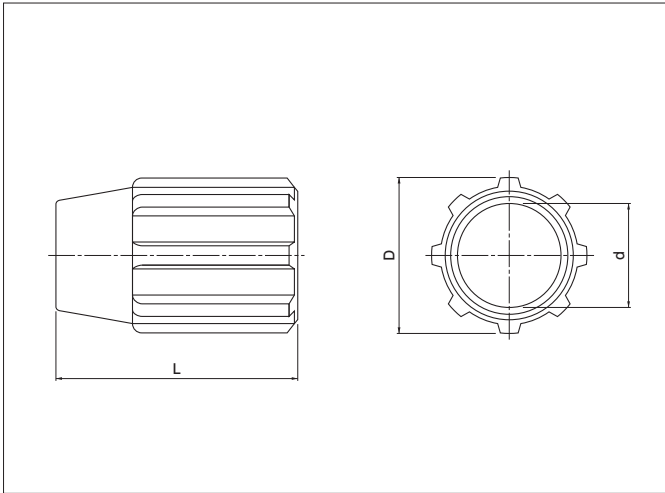

No. of circuits	Model No.	D	d	L	Q'ty/box
9	J-CN9 · 15	13.6	7.2	19.0	1,000
15					
25	J-CN25	16.4	8.4	25.0	1,000
37	J-CN37	18.8	10.4	28.0	1,500

Material and Surface finish, etc.

Glass-filled, PBT, UL94V-0, black

RoHS2 compliance

E-ring

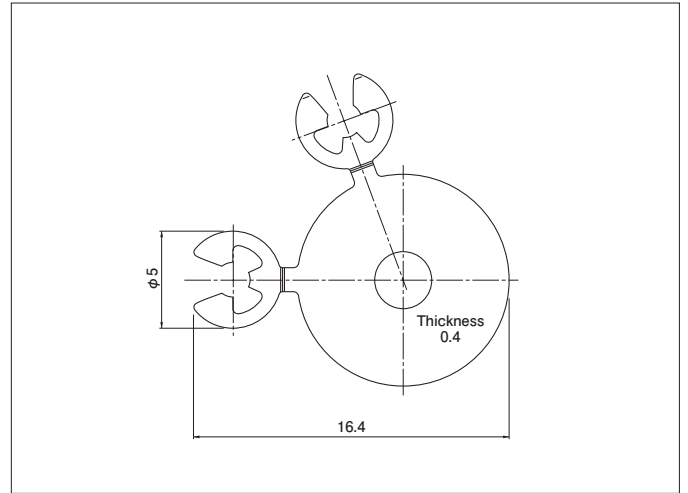

Model No.	Q'ty/box
J-ER	5,000

Material and Surface finish, etc.

Stainless steel

RoHS2 compliance

Note: The cover nuts, lock screws and E-rings are used with both the J and JK series connectors.

Lock screw

No.4-40UNC (Inch thread)

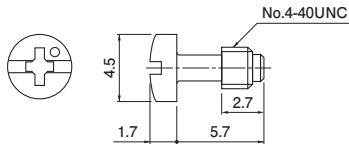

M2.6 (Metric thread)

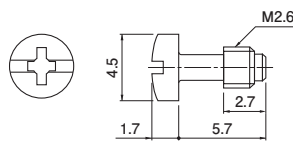

M3 (Metric thread)

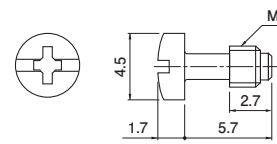

Type of screw	Model No.	Q'ty/box
No.4-40UNC (Inch thread)	J-SL-1C	5,000
M2.6 (Metric thread)	J-SL-2C	5,000
M3 (Metric thread)	J-SL-3C	5,000

Material and Surface finish, etc.

Steel, copper-undercoated, nickel-plated

RoHS2 compliance

Use the following Model Nos. when ordering J-covers as a set.

J series		JK series		Parts in one set	Q'ty/box
No. of circuits	Model No.	No. of circuits	Model No.		
9	J-C9-()C	15	JK-C15-()C	Shielding cover A 1 pc.	25
15	J-C15-()C	—	—	Shielding cover B 1 pc.	25
25	J-C25-()C	—	—	Cover nut 1 pc.	20
37	J-C37-()C	—	—	Lock screw 2 pcs.	10
				E-ring 1 set	

RoHS2 compliance

Note: In the above lock screw model numbers, the number in parentheses indicates the type of screw-1: Inch thread (No.4-40UNC), 2: Metric thread (M2.6), 3: Metric thread (M3).

D SUBMINIATURE CONNECTOR J&JK SERIES

J-cover assembly procedure

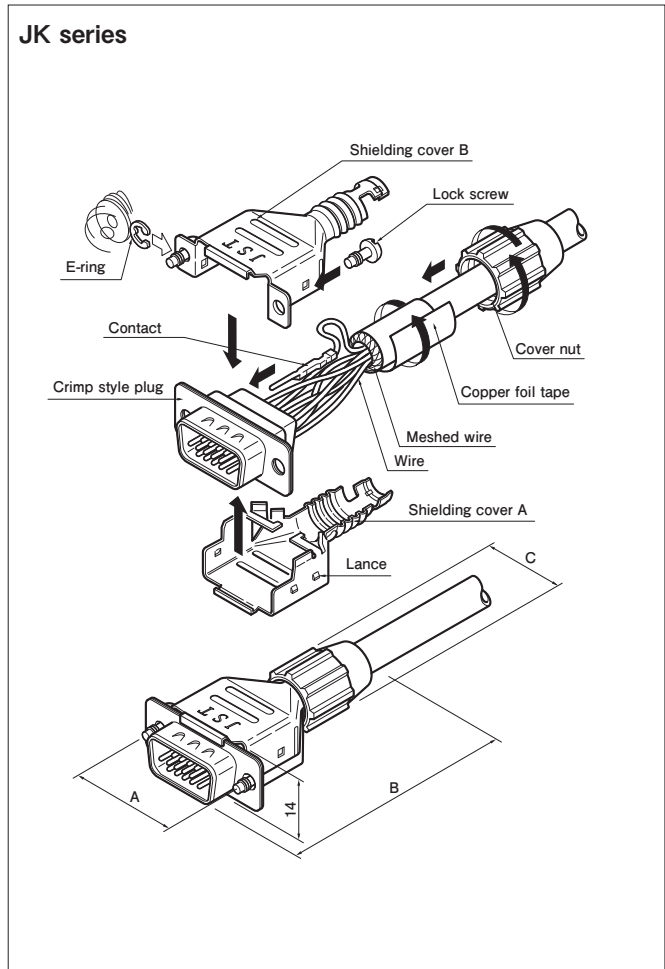
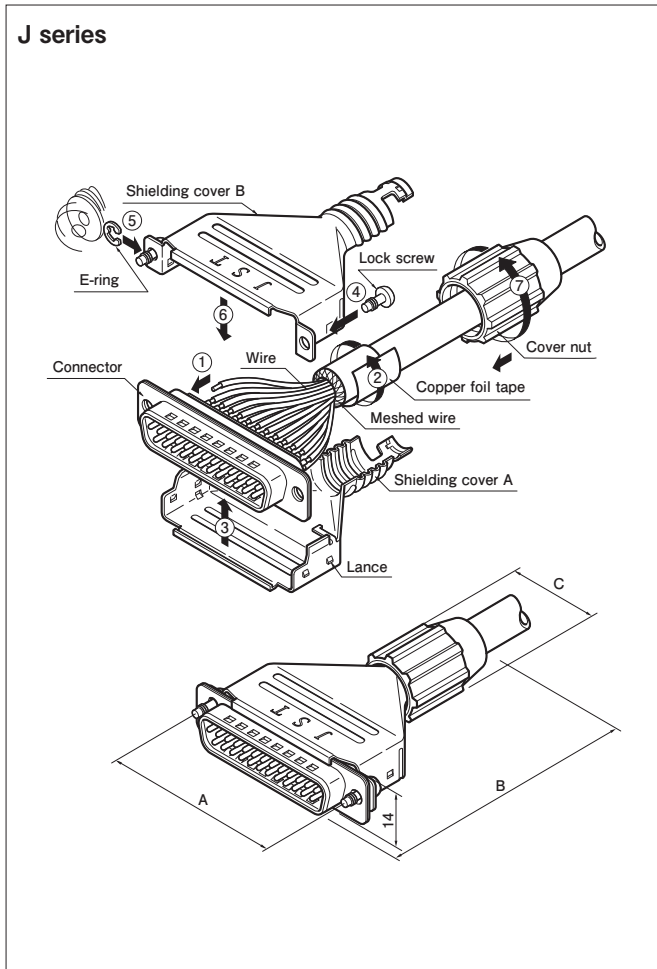

Assembly procedure

1. Connect wires to the connector by soldering or crimping.
2. Fold back the braided shielding wire along the outside insulation and wind the copper foil tape around the shielding wire.
3. Install the connector into shielding cover A.
4. Screw the lock screws onto shielding cover B.
5. Install the E-rings.
6. Align shielding cover B with shielding cover A and press shielding cover B until it engages the lances of shielding cover A.
7. Tighten the cover nut until the predetermined position is reached.

Note: For details of the J-cover assembly procedure, please refer to the processing specifications separately available. The shielding effect of the J-cover is critically dependent on proper assembly.

Dimensions after assembly

No. of circuits		Dimensions (mm)		
J series	JK series	A	B	C
9	15	24.99	(49.0)	13.6
15	—	33.32	(53.0)	13.6
25	—	47.04	(64.5)	16.4
37	—	63.50	(78.5)	18.9



D SUBMINIATURE J&JK SERIES

Accessories/EMI prevention overmolding cover

MOLD COVER



Features

- This cover completely encloses all wire connections to the connector, and its braided wire crimp section ensures a reliable ground connection. The result is excellent shielding.
- This cover is sturdy enough to withstand the high pressure necessary during overmolding. It can thus be finish-molded directly.
- * Please refer to the "Handling Precautions for Terminals and Connectors" on our website (listed in the "Technical Documents" column on the Product Information page) before use.
- * Contact JST for details.
- * RoHS2 compliance

Applicable cable diameter

No. of circuits		Cable O.D. (mm)
J series	JK series	
9	15	8.6 \pm 0.2
15	—	7.6 \pm 0.2
25	—	8.6 \pm 0.2

Note: Contact JST for cables other than those listed above.

Ferrule

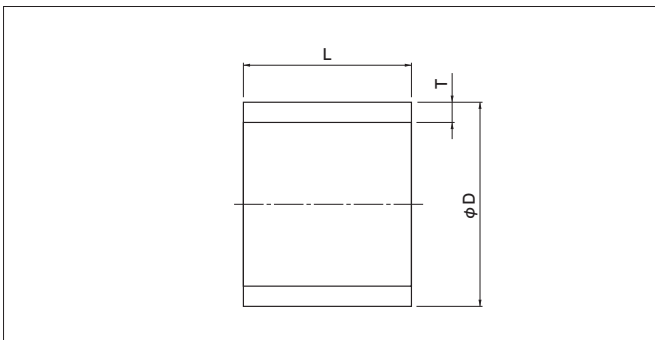

No. of circuits		Ferrule	Dimensions (mm)		
J series	JK series		φD	T	L
9 · 25	15	A	8.0	0.5	4.0
		B	11.3	0.6	8.0
15	—	A	7.0	0.5	4.0
		B	10.5	0.6	8.0

RoHS2 compliance

Mold cover A

JK-MC15A-3
J-MC15A

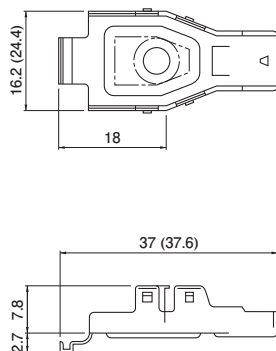

*Dimensions in () are those for the J-MC15A.

Mold cover B

JK-MC15B-3
J-MC15B

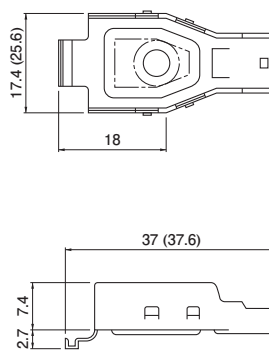

*Dimensions in () are those for the J-MC15B.

RoHS2 compliance

D SUBMINIATURE CONNECTOR J&JK SERIES

Mold cover assembly procedure

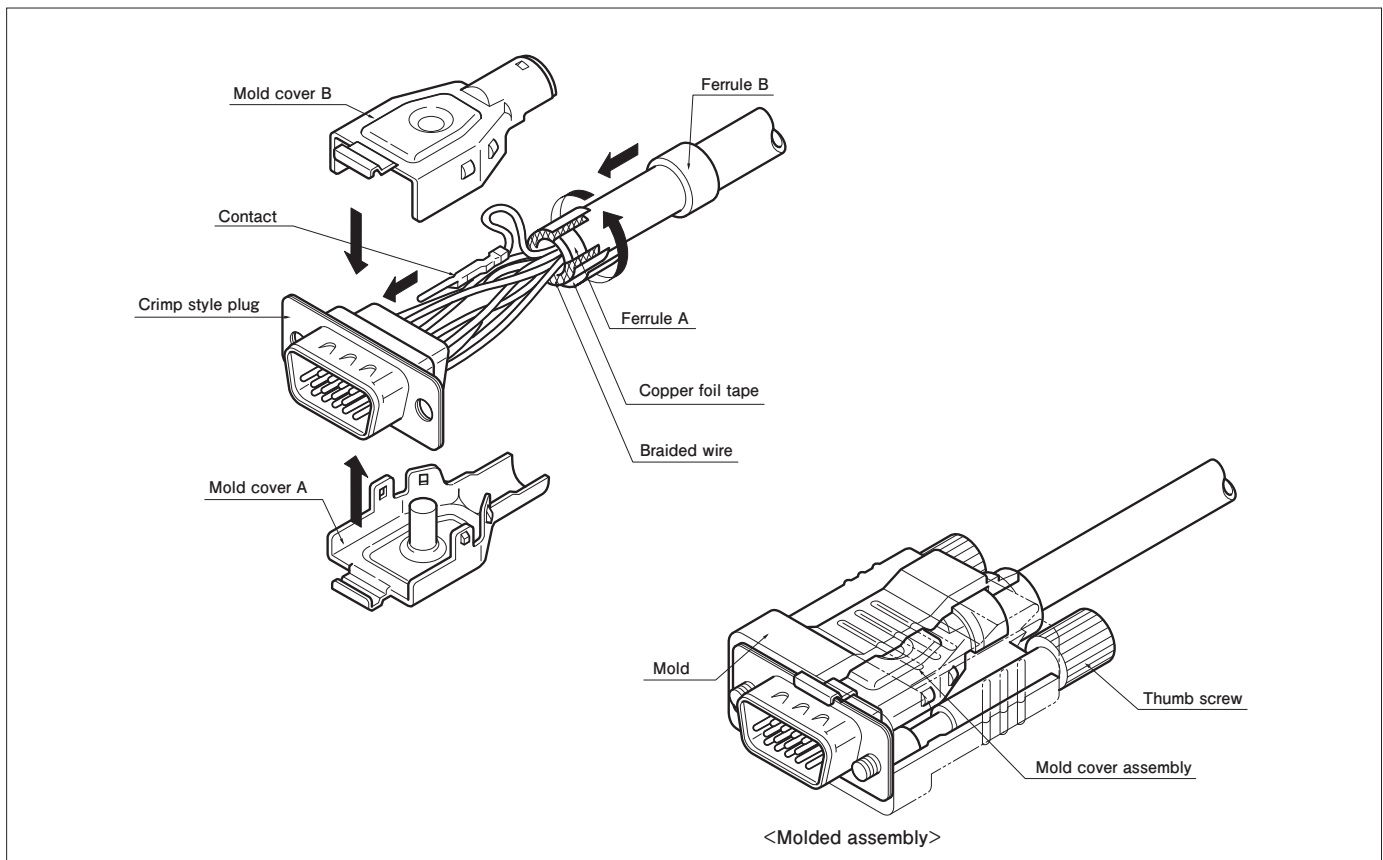

Note: Customers please prepare mold and thumb screws on your own.

Assembly procedure

1. Processing braided shielding wire

Pass the cable through ferrule B and remove the insulation at the end of the cable. Install ferrule A and fold back the braided shielding wire along the outside insulation. Then wind the copper foil tape around the shielding wire.

3. Assembling the mold covers

Align mold cover B with mold cover A and press mold cover B until it engages the lances of mold cover A. Install ferrule B over the cable holding section of the cover assembly and crimp ferrule B. This completes the assembly.

2. Connecting the wires to the contacts

Connect the wires to the contacts by crimping and insert the contacts into the housing.

No. of circuits		Parts name	Model No.	Material and Surface finish, etc.	Q'ty/bag
J series	JK series				
9	15	Mold cover A	JK-MC15A-3	Steel, copper-undercoated, nickel-plated	500
		Mold cover B	JK-MC15B-3		
		Ferrule A	JK-FL15A-8.0C	Copper, tin-plated	1,000
		Ferrule B	JK-FL15B-11.3		500
15	-	Mold cover A	J-MC15A	Steel, copper-undercoated, nickel-plated	200
		Mold cover B	J-MC15B		
		Ferrule B	J-FL15B-10.5	Copper, tin-plated	500

RoHS2 compliance

Crimping machine, Applicator

Contact	Crimping machine	Applicator	Crimp applicator with dies
JK-FL15B-11.3	AP-K2N	MKS-L-RG	APLMK JK-MC15
J-FL15B-10.5			APLSC JK-MC15



D SUBMINIATURE CONNECTOR J·JH·JK&KH SERIES

Accessories/Lock screw block

A variety of accessories are available for the D subminiature connectors.

LOCK SCREW BLOCK



**Hexagonal lock screw block
(inch thread: No.4-40UNC)**

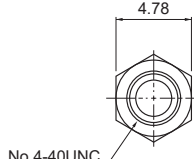

No.4-40UNC

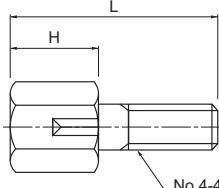

No.4-40UNC

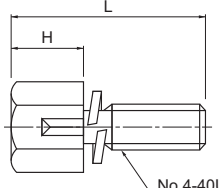

No.4-40UNC

Type A

Type B
Hexagonal lock screw &
spring washer are integrated

Dimension / Model No.	Applicable series	J series right angle through-hole type	JK series right angle through-hole type	J series straight through-hole type	JH series right angle through-hole type KH series right angle through-hole type	Dimensions H (mm)	Type	Attachment	Q'ty/box
	JK series straight through-hole type	JK series right angle through-hole type	J series straight through-hole type	JH series right angle through-hole type KH series right angle through-hole type					
Dimension L (mm)		13.1	15.0	10.0	11.8				
Model No.	JFS-4S-C1N	KFS-4S-C1N	—	—	—	5.5	A	Spring washer .. 1 pc. Nut 1 pc.	2,000
	JFS-4S-B1W	KFS-4S-B1W	SFS-4S-B1W	HFS-4S-B1W	4.8	Spring washer .. 1 pc.			
	JFS-4S-C1W	KFS-4S-C1W	—	—	5.5	B	—		
	JFS-4S-B1WM	KFS-4S-B1WM	SFS-4S-B1WM	HFS-4S-B1WM	4.8				
	JFS-4S-C1WM	KFS-4S-C1WM	—	HFS-4S-C1WM	5.5				

RoHS2 compliance



**Hexagonal lock screw block
(metric thread: M3)**

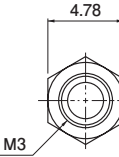

M3

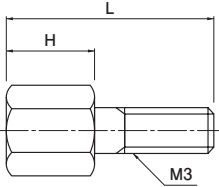

M3

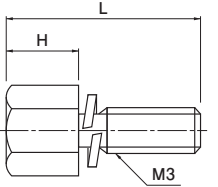

M3

Type A

Type B
Hexagonal lock screw &
spring washer are integrated

Dimension/ Model No.	Applicable series	JK series right angle through-hole type	J series straight through-hole type	JH series right angle through-hole type KH series right angle through-hole type	Dimensions H (mm)	Type	Attachment	Q'ty/box
	JK series right angle through-hole type	J series straight through-hole type	JH series right angle through-hole type KH series right angle through-hole type					
Dimension L (mm)		15.0	10.0	11.8				
Model No.	—	—	SFS-3S-B1W	—	4.8	A	Spring washer .. 1 pc.	2,000
	—	—	SFS-3S-C1W	HFS-3S-C1W	5.5			
	—	—	—	—	4.8	B	—	
	KFS-3S-C1WM	—	—	—	5.5			

RoHS2 compliance

D SUBMINIATURE CONNECTOR J·JH·JK&KH SERIES



**Hexagonal lock screw block
(metric thread: M2.6)**

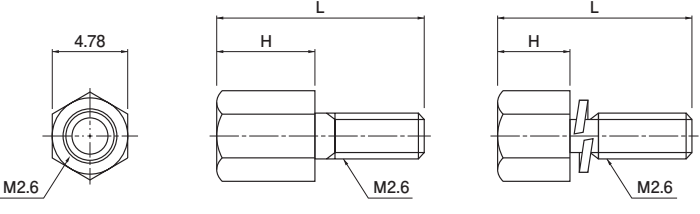

Type A **Type B**
Hexagonal lock screw & spring washer are integrated

Applicable series	J series right angle through-hole type JK series straight through-hole type	JK series right angle through-hole type	J series straight through-hole type	Dimensions H (mm)	Type	Attachment	Q'ty/box
Dimension/Model No.	Dimension L (mm)	13.1	15.0				
Model No.	JFS-2.6S-C1N	—	—	5.5	A	Spring washer .. 1 pc. Nut 1 pc.	2,000
	JFS-2.6S-B1W	KFS-2.6S-B1W	SFS-2.6S-B1W	4.8		Spring washer .. 1 pc.	
	JFS-2.6S-B1WM	—	SFS-2.6S-B1WM	4.8	B	—	
	JFS-2.6S-C1WM	—	SFS-2.6S-C1WM	5.5			

RoHS2 compliance



**Rectangular lock screw block
(metric thread: M2.6)**

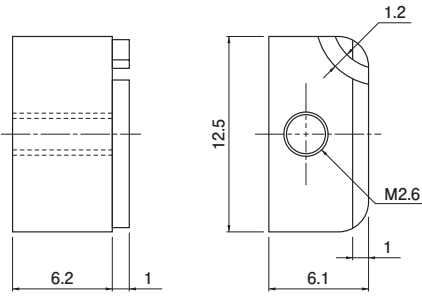

Model No.	Attachment	Q'ty/box
JFS-2.6R-N	Spring washer 1 pc. Set screw 1 pc.	1,000

RoHS2 compliance

D SUBMINIATURE CONNECTOR J·JH·JK&KH SERIES

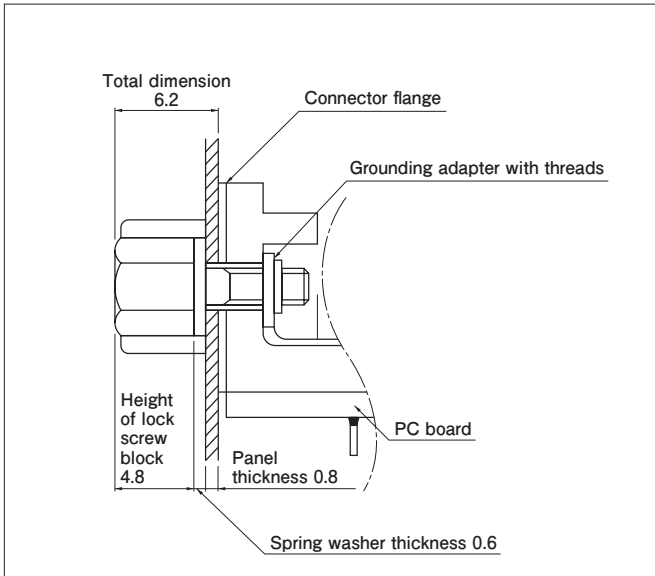

Application examples of hexagonal lock screw blocks

- The resulting total dimension from the connector flange to the top of the hexagonal lock screw block must be 6.2 mm after assembly.
- The D subminiature connector can be installed on the Panel by simply tightening the hexagonal lock screw block together with grounding adapter, which has an identical thread to that of the F, G, and H types.

DUST COVER (for receptacles)

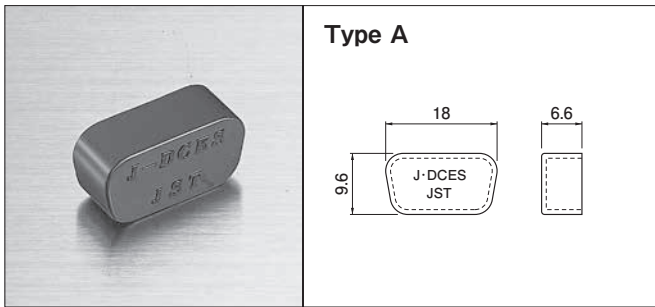

Type A

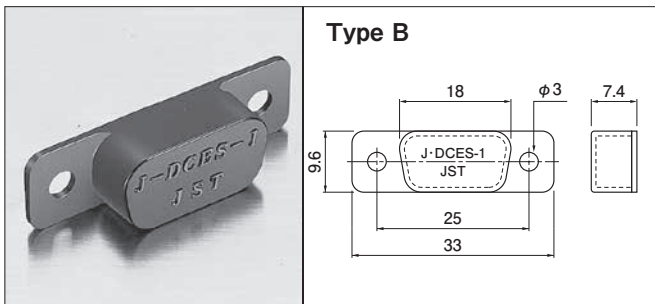

Type B

Type	No. of circuits		Model No.	Q'ty/box
	J series	JK series		
A	9	15	J-DCES	1,000
B			J-DCES-1	

Material and Surface finish, etc.

PA, UL94V-0, black

RoHS2 compliance

EXTRACTION TOOL



With this tool, contacts (connected to wires by crimping) can be easily removed if they are improperly inserted into plug and receptacle housings.

Applicable Connector		Model No.
J series		DEJ-0.3
JK series	Plug	KEJ-0.7
	Receptacle	KEJ-0.4

Looking for pricing, stock, or lifecycle information?

Click below to explore more details on WIN SOURCE:

- [⊖ View JK-SP2140\(LF\)\(SN\) on WIN SOURCE](#)
- [⊖ JST Sales America Inc. Information](#)

Optimize Your Supply Chain with WIN SOURCE Solutions

- ✓ Global Sourcing Solution
- ✓ Obsolete Management
- ✓ Cost Control Management
- ✓ Shortage Management
- ✓ Alternative Solution
- ✓ Excess Inventory Management