

GRF7001

High-Linearity Single-Ended Mixer with Integrated LO Buffer

FEATURES

- RF/IF Range: 0.01 to 4 GHz
- LO Range: 0.1 to 4 GHz
- Integrated LO Buffer
- Flexible Bias Voltage
- Compact 1.5 x 1.5 mm DFN-6 Package
- Process: GaAs pHEMT

Reference: 3 V / 10 mA

- RF: 808 MHz
- LO: 965 MHz, 0 dBm
- IF: 157 MHz
- Conversion Loss: 6 dB
- IIP3: 25 dBm
- IP1dB: 19 dBm

APPLICATIONS

- Bi-directional Mixer for High-Linearity Transmit/Receive Chains
- Low-Power Applications

DESCRIPTION

The GRF7001 is a broadband (0.01 to 4 GHz) high-linearity mixer with an integrated LO buffer that can be used as either an up or down converter. The device inputs and outputs are single-ended and easily matched to 50 Ω . Implementation requires an external image-reject filter on the RF port and a bandpass filter on the IF port. Pins 4 and 6 can be used for either RF or IF with appropriate filtering in place.

The integrated LO buffer operates from a single positive supply of 1.8 to 5 volts for both the V_{DD} and V_{ENABLE} inputs.

Please consult with the GRF applications engineering team for custom tuning/evaluation board data.

BLOCK DIAGRAM

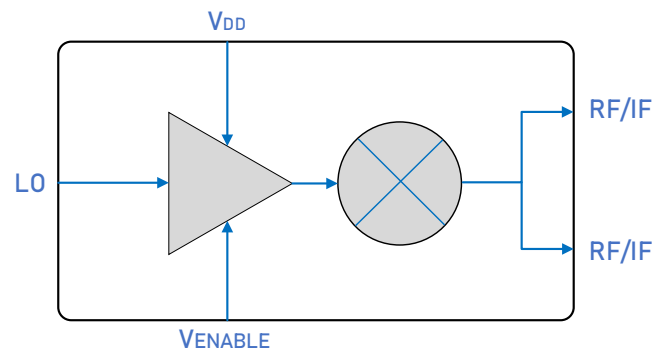

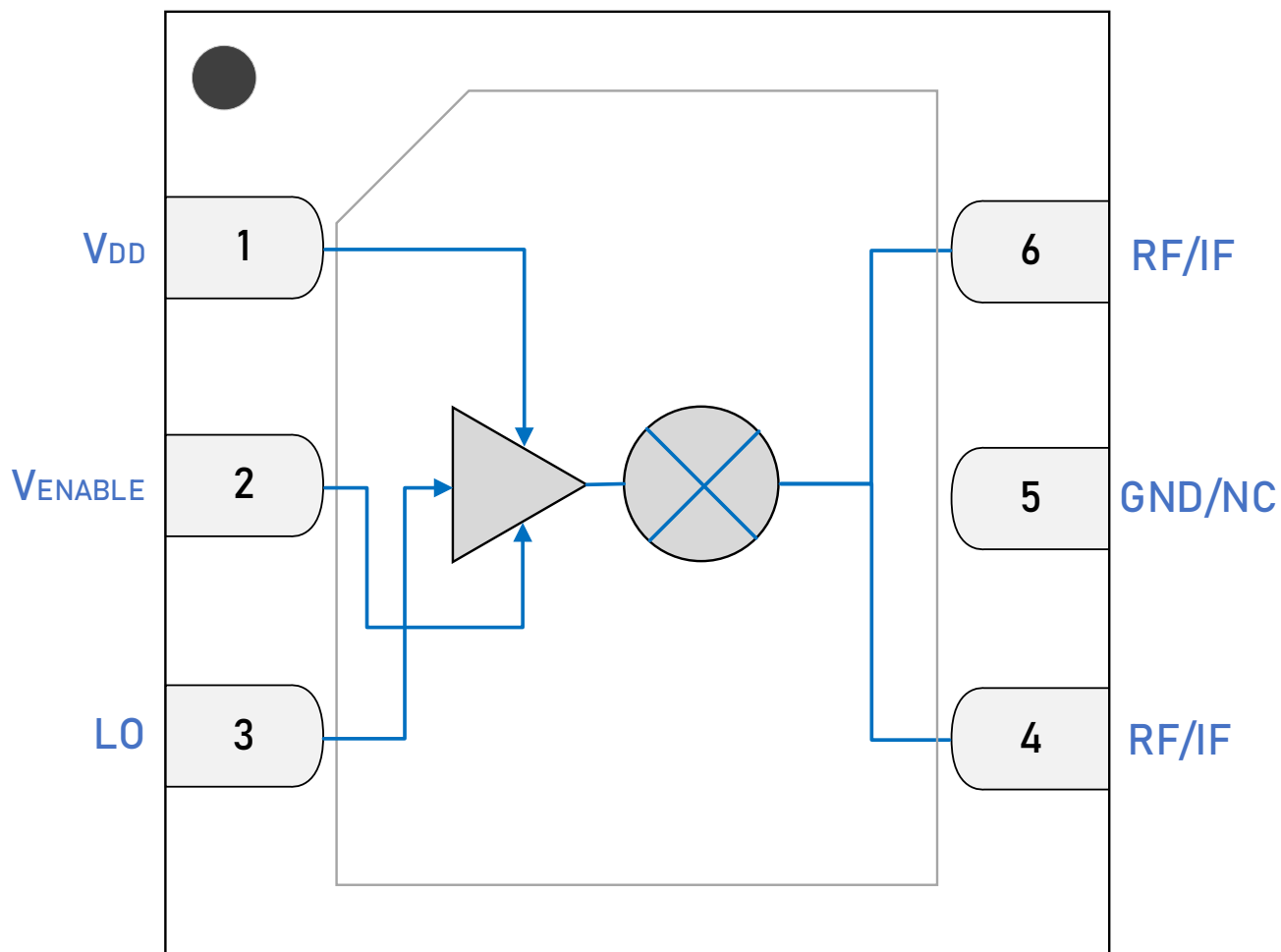

1.5 x 1.5 mm DFN-6 Pin Out (Top View)

Pin Assignments

Pin	Name	Description	Note
1	V _{DD}	LO Buffer Voltage	V _{DD} : 3 to 5 Volts.
2	V _{ENABLE}	LO Buffer Control Voltage	LO Buffer Enabled: 3 to 5 volts, V _{ENABLE} ≤ 0.2 volts disables the LO buffer. V _{ENABLE} ≤ V _{DD} .
3	LO	LO Buffer Input Signal	Optimal LO input power: 0 dBm +/- 3 dB.
4, 6	RF/IF	RF/IF Input or Output Signal	External filter required.
5	GND/NC	Ground or No Connect	No internal connection to die. We recommend connecting this pin to ground.
PKG BASE	GND	Ground	Provides DC and RF ground for the Mixer, as well as thermal heat sink. Recommend multiple 8 mil vias beneath the package for optimal RF and thermal performance. Refer to evaluation board top layer graphic on schematic page.

Absolute Ratings

Parameter	Symbol	Min.	Max.	Unit
LO Buffer Supply Voltage	V_{DD}	0	6	V
LO Buffer Control Voltage	V_{ENABLE}	0	V_{DD}	V
RF/IF/LO Input Power: Load VSWR < 2:1, $V_{DD} = 5$ V	$P_{IN\ MAX}$		20	dBm
Operating Temperature (package base)	$T_{PKG\ BASE}$	-40	105	°C
Maximum Channel Temperature (MTTF > 10 ⁶ Hours)	T_{MAX}		170	°C
Maximum Dissipated Power	$P_{DISS\ MAX}$		200	mW

Electrostatic Discharge

Charged Device Model	CDM	1500		V
Human Body Model	HBM	250		V

Storage

Storage Temperature	T_{STG}	-65	150	°C
Moisture Sensitivity Level	MSL		1	--



Caution! ESD Sensitive Device.

Exceeding Absolute Maximum Rating conditions may cause permanent damage.

Note: For additional information, please refer to *Manufacturing Note MN-001 — Package and Manufacturing Information*.



All Guerrilla RF products are provided in RoHS compliant lead (Pb)-free packaging requiring no exemptions. Additional information for this topic can be found at this link - [Environmental and Restricted Substance Statement Library](#)

Recommended Operating Conditions

Parameter	Symbol	Specification			Unit	Condition
		Min.	Typ.	Max.		
LO Buffer Supply Voltage	V_{DD}	1.8	3	5	V	
LO Buffer Control Voltage	V_{ENABLE}		V_{DD}		V	Set equal to V_{DD} .
Operating Temperature (package base)	$T_{PKG\ BASE}$	-40		105	°C	
RF Frequency Range	F_{RF}	10	808	4000	MHz	
LO Frequency Range	F_{LO}	100	965	4000	MHz	
IF Frequency	F_{IF}	10	157	4000	MHz	
LO Buffer Input Power			0		dBm	

Nominal Operating Parameters – General

The following conditions apply unless noted otherwise: typical application schematic, $V_{DD} = 3\text{ V}$, $V_{ENABLE} = 3\text{ V}$, $I_{DD} = 12.5\text{ mA}$, $F_{RF} = 808\text{ MHz}$, $F_{LO} = 965\text{ MHz}$, $F_{IF} = 157\text{ MHz}$, $LO = 0\text{ dBm}$, $T_{PKG\text{ BASE}} = 25\text{ }^\circ\text{C}$. Evaluation board losses are included within the specifications.

Parameter	Symbol	Specification			Unit	Condition
		Min.	Typ.	Max.		
Supply Voltage	V_{DD}	1.8	3	5	V	
Supply Current	I_{DD}		12.5		mA	

Thermal Data

Thermal Resistance: (Infrared Scan)	Θ_{JC}		91		$^\circ\text{C}/\text{W}$	On standard evaluation board (note 2).
Channel Temperature at 85 $^\circ\text{C}$. Reference Package Base	T_j		90		$^\circ\text{C}$	$V_{DD} = 3\text{ V}$, $V_{ENABLE} = 3\text{ V}$, $I_{BUFFER} = 13\text{ mA}$, RF OFF. $P_{DISS} = \sim 40\text{ mW}$.

Note 2: MTTF > 10^6 hours for $T_{CHANNEL} \leq 170\text{ }^\circ\text{C}$.

Nominal Operating Parameters – RF

The following conditions apply unless noted otherwise: typical application schematic, $V_{DD} = 3\text{ V}$, $V_{ENABLE} = 3\text{ V}$, $I_{DD} = 12.5\text{ mA}$, $F_{RF} = 808\text{ MHz}$, $F_{LO} = 965\text{ MHz}$, $F_{IF} = 157\text{ MHz}$, $LO = 0\text{ dBm}$, $T_{PKG\text{ BASE}} = 25\text{ }^{\circ}\text{C}$. Evaluation board losses are included within the specifications.

Parameter	Symbol	Specification			Unit	Condition
		Min.	Typ.	Max.		
Conversion Gain	S21		-5.5		dB	
Input 3rd Order Intercept Point	IIP3		25		dBm	
Input P1dB Compression Power	IP1dB		19		dBm	
LO to IF Rejection	LO_IF		20		dB	Measured with LO = 0 dBm with band-specific matching.
LO to RF Rejection	LO_RF		10.5		dB	Measured with LO = 0 dBm with band-specific matching.
LO Buffer Current	I _{BUFFER}		10		mA	Measured with LO = 0 dBm with band-specific matching.
LO Buffer Enable Current	I _{ENABLE}		0.5		mA	

GRF7001 Typical Operating Curves:

GRF7001 ConversionGain vs Frequency

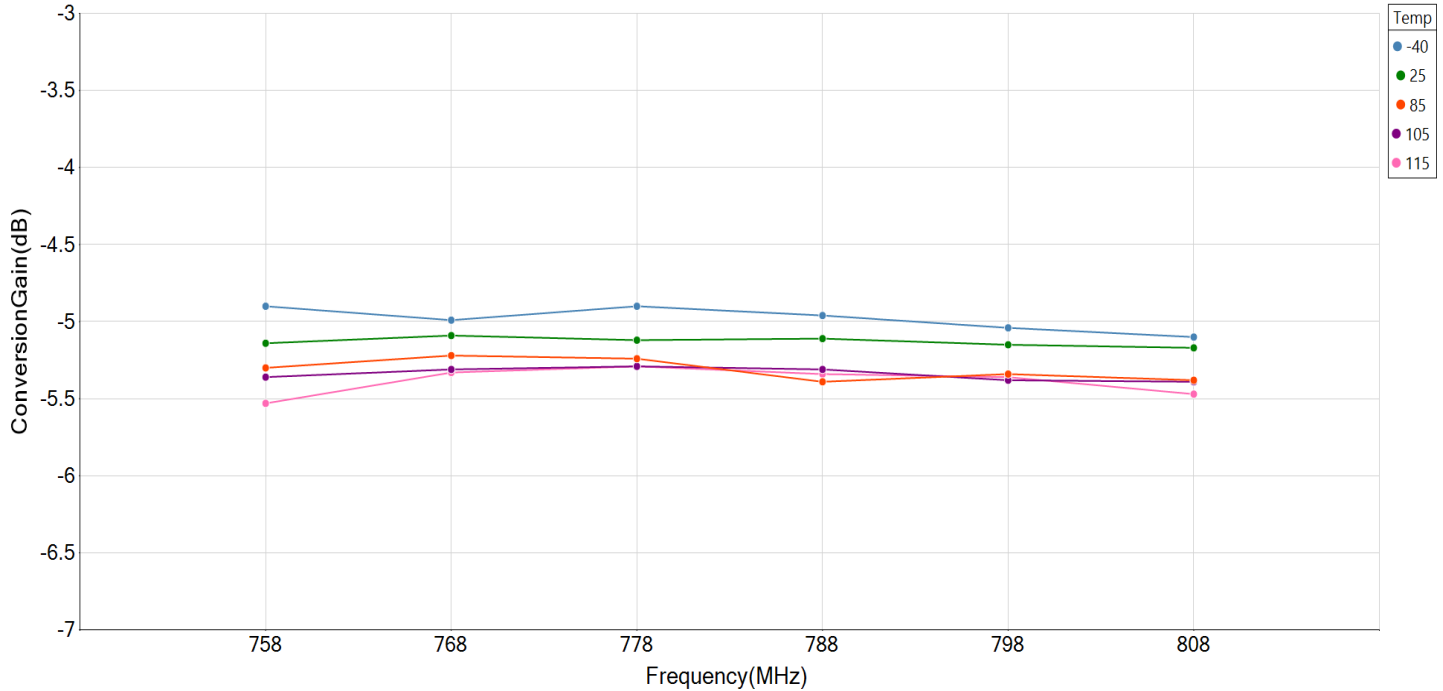

GRF7001 Idd vs Frequency

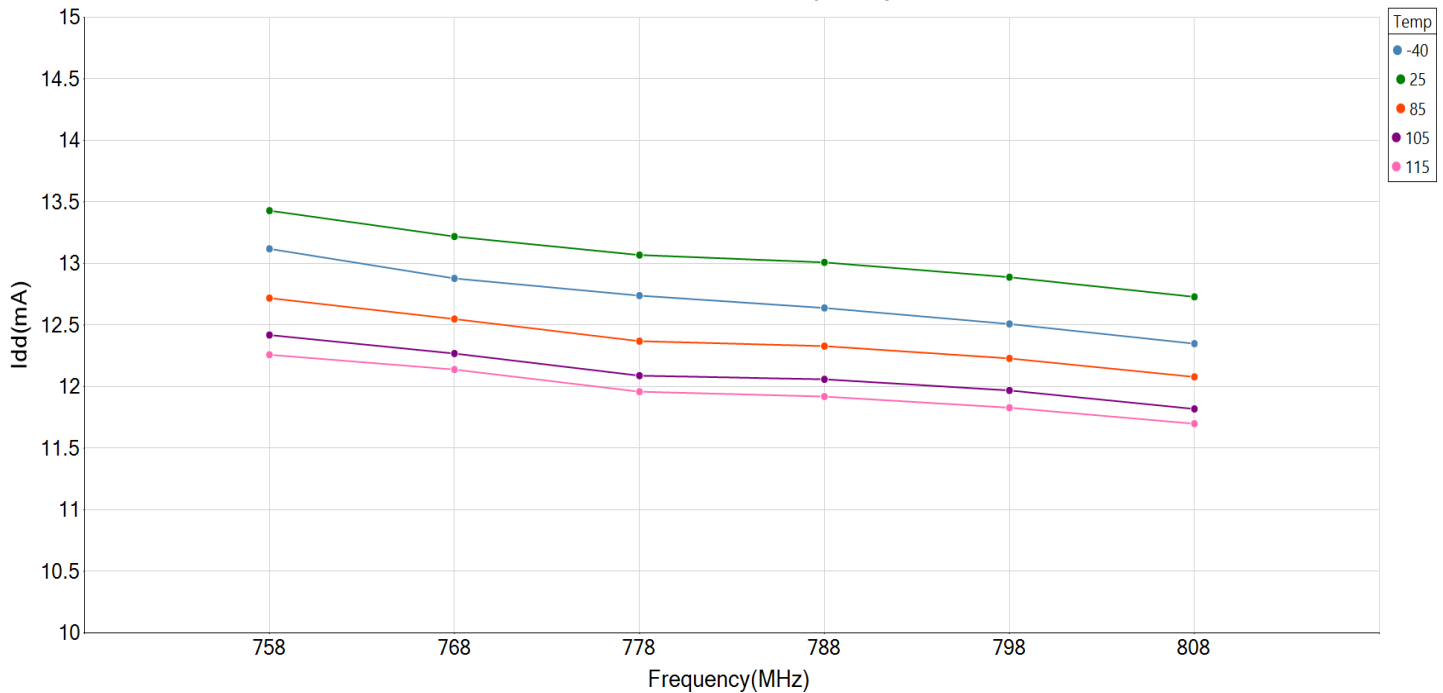

GRF7001 Typical Operating Curves:

GRF7001 IP1dB vs Frequency

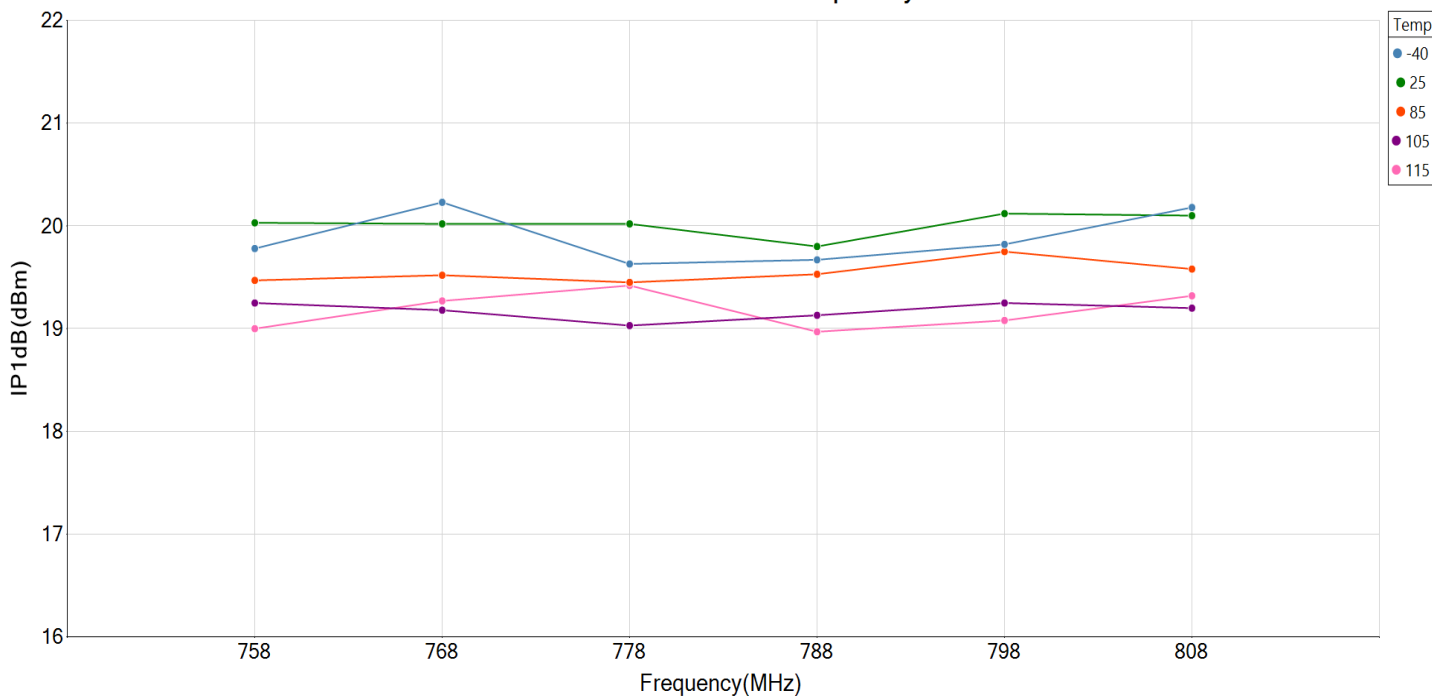

GRF7001 IIP3 vs Frequency: LO Pin=0dBm; RF Pin=-10dBm

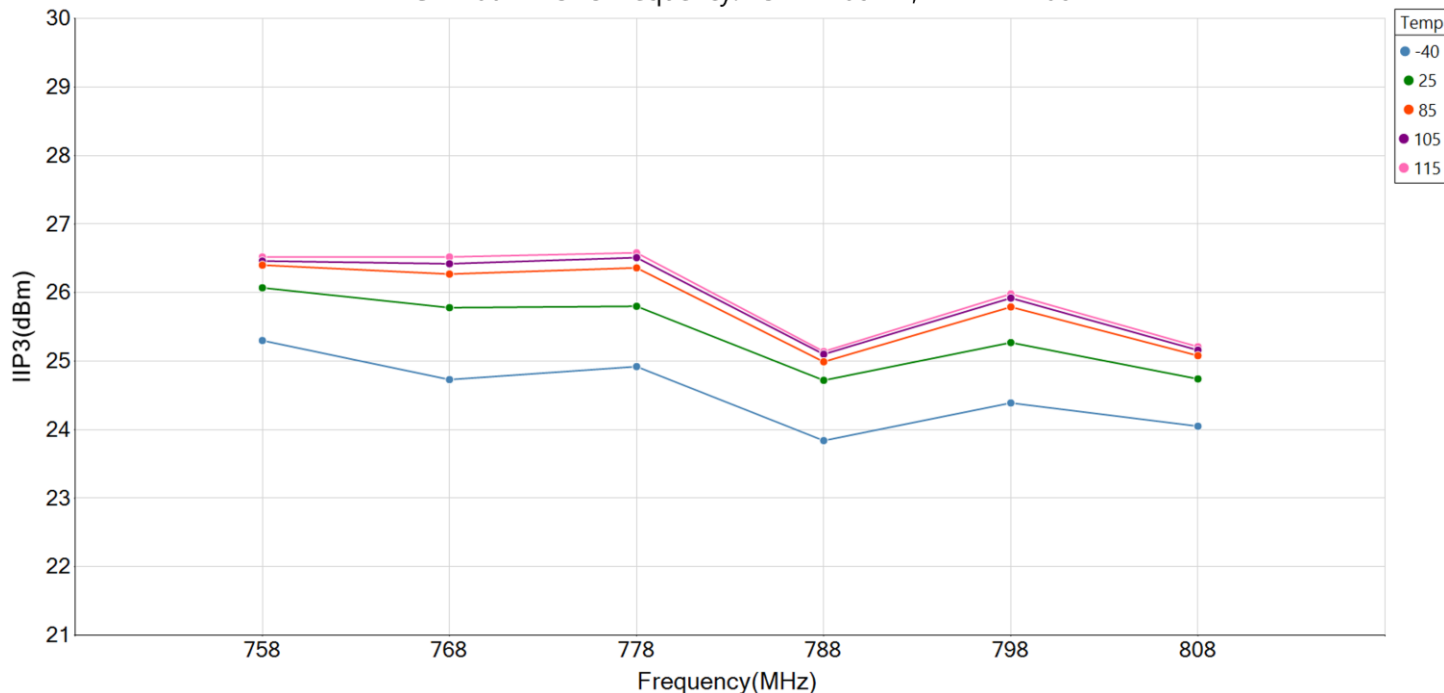

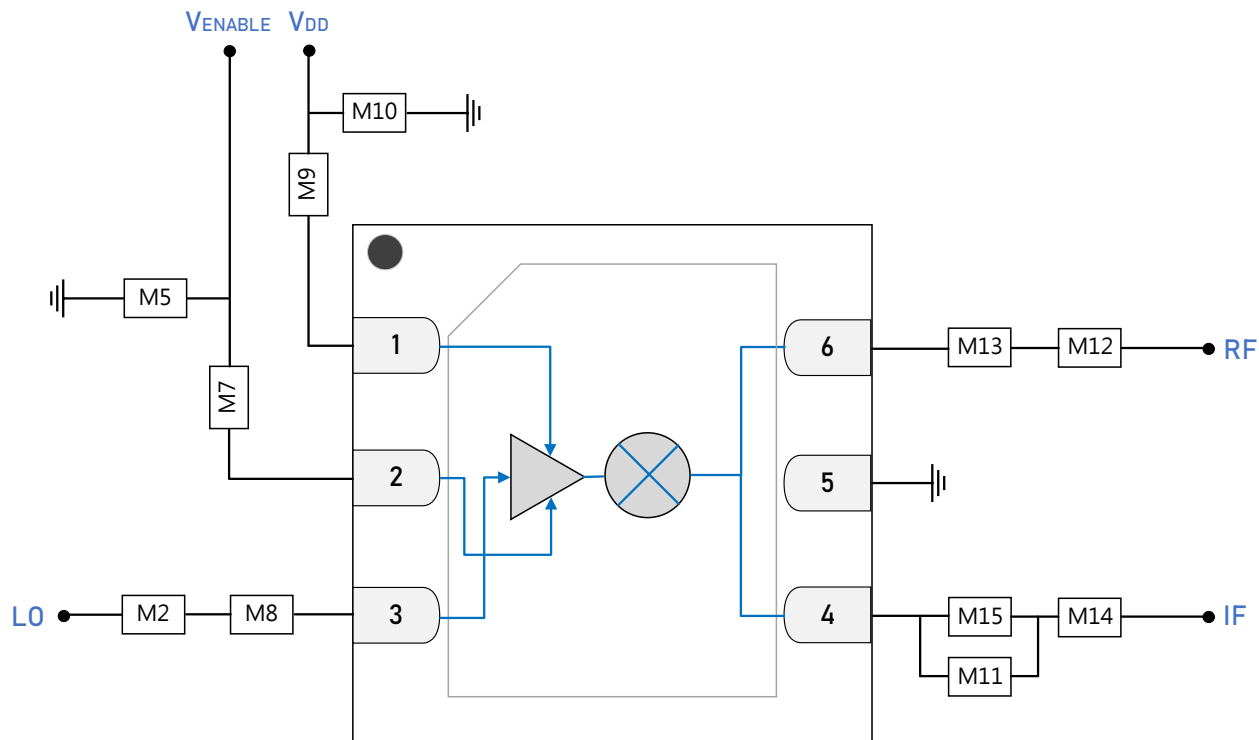

GRF7001 Standard Evaluation Board Schematic

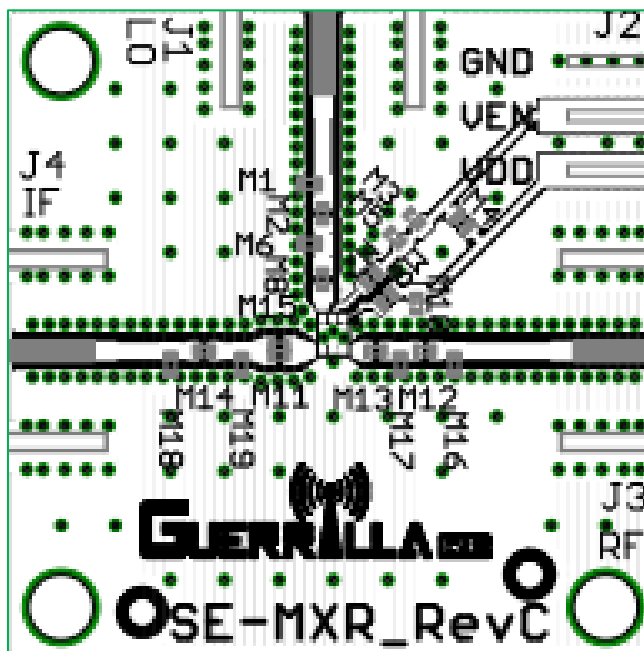

GRF7001 Evaluation Board Assembly Diagram

GRF7001 Evaluation Board Assembly Diagram Reference:

RF frequency: 758 to 808 MHz, LO frequency: 915 to 1015 MHz, IF frequency: 157 MHz

Component	Type	Manufacturer	Family	Value	Package Size	Substitution
M2	Capacitor	Murata	GJM	33 pF	0402	ok
M5	Capacitor	Murata	GRM	0.1 μ F	0402	ok
M7	Resistor	Various	5%	See table	0402	ok
M8	Inductor	Murata	LQG	5.6 nH	0402	ok
M9	Inductor	Murata	LQG	18 nH	0402	ok
M10	Capacitor	Murata	GRM	1000 pF	0402	ok
M11	Capacitor	Murata	GJM	3.9 pF	0402	ok
M12	Inductor	Murata	LQG	8.2 nH	0402	ok
M13	Capacitor	Murata	GRM	3.9 pF	0402	ok
M14	Capacitor	Murata	GRM	330 pF	0402	ok
M15	Inductor	Murata	LQG	8.2 nH	0402	ok
Evaluation Board	SE-MXR_RevC					

LO Buffer I_{DD} vs. V_{DD} vs. V_{ENABLE} Bias Resistor

$V_{DD} = V_{ENABLE}$ (V)	M7 (Ω)	I_{DD} (mA)
3	0	10
3.3	20 k	10
4	60 k	10
4.5	80 k	10
5	100 k	10

Note regarding evaluation board matching: The evaluation board accommodates simple LC matching/filtering to implement a chosen frequency scheme. It should be noted that the RF and IF ports of the mixer are connected to the same node on the mixer die. This means that the IF port must reject the RF signals and vice-versa.

For this reason, GRF applications engineering cannot effectively support tuned evaluation board requests in which the lowest RF frequency is not at least 3X the highest IF frequency. Applications such as these can be viable if high-performance SAW-type filters are used to achieve the necessary RF/IF frequency separation. The tables on the following page show suggested RF, LO and IF LC matching/filter values for a range of common frequency schemes.

GRF7001 Port Matching vs. Frequency:

RF					IF	
RF (MHz)	RF Port		IF Port		IF (MHz)	IF Port
	M12 (nH)	M13 (pF)	M11 (pF)	M15 (nH)		M14 (pF)
450	12	12	12	12	10	100,000
520	10	8.2	6.8	12	50	1000
750	8.2	6.8	6.8	8.2	100	470
850	8.2	3.9	3.9	8.2	150	330
950	8.2	3.6	3.6	8.2	200	220
1300	4.3	3.3	3.3	4.7	250	100
1500	3.9	3.3	3.3	3.0	300	100
1900	2.4	2.4	2.4	2.4	400	100
Note: The DC blocking capacitor value used for M14 is somewhat flexible. The capacitor should be a reasonably good short for the frequency of interest.					500	100
					700	100
					900	100

LO			
LO (MHz)	LO Port		Choke
	M8 (nH)	M2 (pF)	M9 (nH)
400	22	100	68
500	9.1	68	68
650	7.5	56	33
750	6.8	47	33
800	6.8	47	33
950	5.6	33	18
1100	5.6	30	15
1600	5.6	15	6.2
1700	5.6	15	5.1

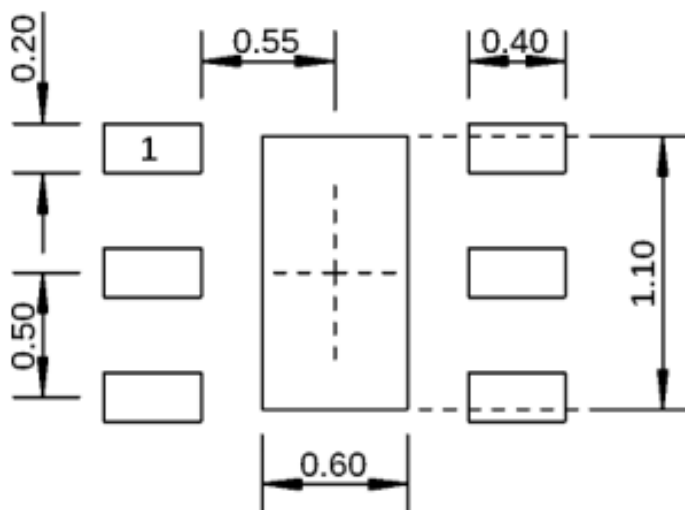

1.5 x 1.5 mm DFN-6 Suggested PCB Footprint (Top View)

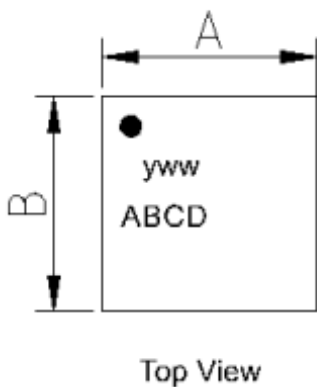

Top View

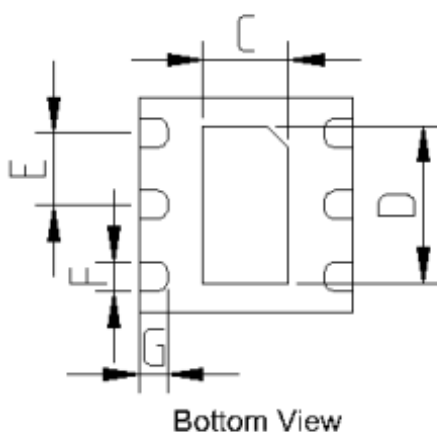

Bottom View

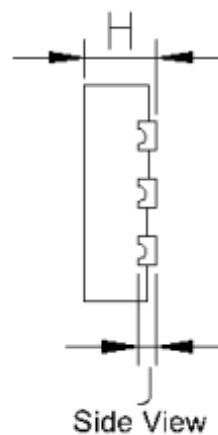

Side View

Dimensions (mm)	
A	1.5 +/- 0.05
B	1.5 +/- 0.05
C	0.6 +/- 0.05
D	1.1 +/- 0.05
E	0.5 BSC
F	0.2 +/- 0.05
G	0.2 +/- 0.05
H	0.45 +/- 0.05
J	0.12 Ref.

Dimensions in millimeters

1.5 x 1.5 mm DFN-6 Package Dimensions

Package Marking Diagram



- Line 1: "Y" = YEAR (single digit). "WW" = WORK WEEK the device was assembled.
- Line 2: "XXXX" = Device PART NUMBER.

Tape and Reel Information

Guerrilla RF's tape and reel specification complies with Electronic Industries Alliance (EIA) standards for "Embossed Carrier Tape of Surface Mount Components for Automatic Handling" (reference EIA-481). See the following page for the Tape and Reel Specification and Device Package Information table, which includes units per reel.

Devices are loaded with pins down into the carrier pocket with protective cover tape and reeled onto a plastic reel. Each reel is packaged in a cardboard box. There are product labels on the reel, the protective ESD bag and the outside surface of the box.

For the Tape and Reel Reference Table, please refer to: [Package Manufacturing Information | Guerrilla RF \(guerrilla-rf.com\)](#)

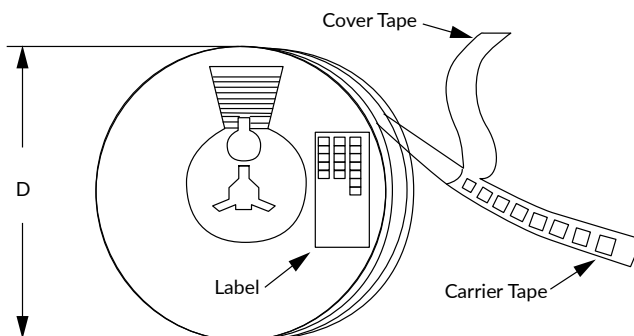

Tape and Reel Packaging with Reel Diameter Noted (D)

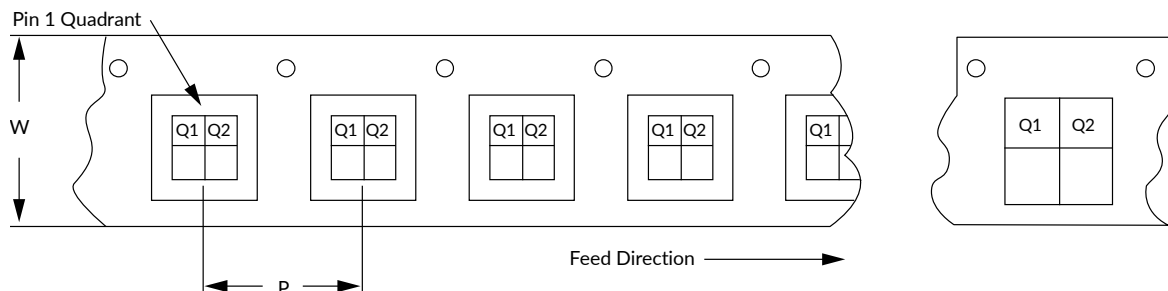

Carrier Tape Width (W), Pitch (P), Feed Direction and Pin 1 Quadrant Information



Revision History

Revision Date	Description of Change
May 9, 2019	Preliminary Data Sheet.
December 20, 2024	Release Ø Data Sheet. Updated specifications and plots.



Data Sheet Classifications

Data Sheet Status	Notes
Advance	S-Parameter and NF data based on EM simulations for the fully packaged device using foundry-supplied transistor S-Parameters. Linearity estimates based on device size, bias condition and experience with related devices.
Preliminary	All data based on limited evaluation board measurements taken within the Guerrilla RF Applications Lab. All parametric values are subject to change pending the collection of additional data.
Release Ø	All data based on measurements taken with <i>production-released</i> material. TYP values are based on a combination of ATE and bench-level measurements, with MIN/MAX limits defined using <i>modelled estimates</i> that account for part-to-part variations and expected process spreads. Although unlikely, future refinements to the TYP/MIN/MAX values may be in order as multiple lots are processed through the factory.
Release A-Z	All data based on measurements taken with production-released material <i>derived from multiple lots which have been fabricated over an extended period of time</i> . MIN/MAX limits may be refined over previous releases as more statistically significant data is collected to account for process spreads.

Information in this data sheet is specific to the Guerrilla RF, Inc. ("Guerrilla RF") product identified.

This data sheet, including the information contained in it, is provided by Guerrilla RF as a service to its customers and may be used for informational purposes only by the customer. Guerrilla RF assumes no responsibility for errors or omissions on this data sheet or the information contained herein. Information provided is believed to be accurate and reliable, however, no responsibility is assumed by Guerrilla RF for its use, nor for any infringement of patents, or other rights of third parties, resulting from its use. Guerrilla RF assumes no liability for any data sheet, data sheet information, materials, products, product information, or other information provided hereunder, including the sale, distribution, reproduction or use of Guerrilla RF products, information or materials.

No license, whether express, implied, by estoppel, by implication or otherwise is granted by this data sheet for any intellectual property of Guerrilla RF, or any third party, including without limitation, patents, patent rights, copyrights, trademarks and trade secrets. All rights are reserved by Guerrilla RF.



All information herein, products, product information, data sheets, and data sheet information are subject to change and availability without notice. Guerrilla RF reserves the right to change component circuitry, recommended application circuitry and specifications at any time without prior notice. Guerrilla RF may further change its data sheet, product information, documentation, products, services, specifications or product descriptions at any time, without notice. Guerrilla RF makes no commitment to update any materials or information and shall have no responsibility whatsoever for conflicts, incompatibilities, or other difficulties arising from any future changes.

GUERRILLA RF INFORMATION, PRODUCTS, PRODUCT INFORMATION, DATA SHEETS AND DATA SHEET INFORMATION ARE PROVIDED "AS IS" AND WITHOUT WARRANTY OF ANY KIND, WHETHER EXPRESS, IMPLIED, STATUTORY, OR OTHERWISE, INCLUDING FITNESS FOR A PARTICULAR PURPOSE OR USE, MERCHANTABILITY, PERFORMANCE, QUALITY OR NON-INFRINGEMENT OF ANY INTELLECTUAL PROPERTY RIGHT; ALL SUCH WARRANTIES ARE HEREBY EXPRESSLY DISCLAIMED. GUERRILLA RF DOES NOT WARRANT THE ACCURACY OR COMPLETENESS OF THE INFORMATION, TEXT, GRAPHICS OR OTHER ITEMS CONTAINED WITHIN THESE MATERIALS. GUERRILLA RF SHALL NOT BE LIABLE FOR ANY DAMAGES, INCLUDING BUT NOT LIMITED TO ANY SPECIAL, INDIRECT, INCIDENTAL, STATUTORY, OR CONSEQUENTIAL DAMAGES, INCLUDING WITHOUT LIMITATION, LOST REVENUES OR LOST PROFITS THAT MAY RESULT FROM THE USE OF THE MATERIALS OR INFORMATION, WHETHER OR NOT THE RECIPIENT OF MATERIALS HAS BEEN ADVISED OF THE POSSIBILITY OF SUCH DAMAGE.

Customers are solely responsible for their use of Guerrilla RF products in the Customer's products and applications or in ways which deviate from Guerrilla RF's published specifications, either intentionally or as a result of design defects, errors, or operation of products outside of published parameters or design specifications. Customers should include design and operating safeguards to minimize these and other risks. Guerrilla RF assumes no liability or responsibility for applications assistance, customer product design, or damage to any equipment resulting from the use of Guerrilla RF products outside of stated published specifications or parameters.

Looking for pricing, stock, or lifecycle information?

Click below to explore more details on WIN SOURCE:

-  [View GRF7001 on WIN SOURCE](#)
-  [Guerrilla RF, Inc. Information](#)

Optimize Your Supply Chain with WIN SOURCE Solutions

-  Global Sourcing Solution
-  Obsolete Management
-  Cost Control Management
-  Shortage Management
-  Alternative Solution
-  Excess Inventory Management