



GaAs PHEMT MMIC DRIVER AMPLIFIER, 5.5 - 17 GHz

Typical Applications

The HMC633LC4 is ideal for:

- Point-to-Point Radios
- Point-to-Multi-Point Radios & VSAT
- LO Driver for Mixers
- Military & Space

Features

- Gain: 30 dB
- P1dB: +23 dBm
- Saturated Power: +23.8 dBm @ 24% PAE
- Supply Voltage: +5V @180 mA
- 50 Ohm Matched Input/Output
- 24 Lead Ceramic 4x4mm SMT Package: 16mm²

Functional Diagram

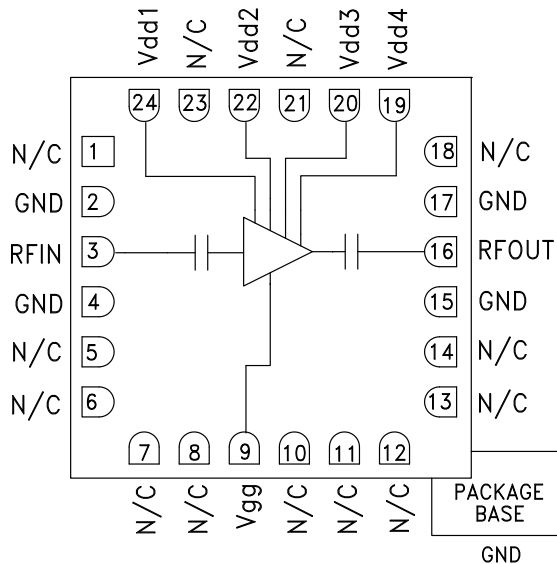

General Description

The HMC633LC4 is a GaAs PHEMT MMIC Driver Amplifier in a leadless 4x4 mm ceramic surface mount package which operates between 5.5 and 17 GHz. The amplifier provides up to 30 dB of gain, +30 dBm Output IP3, and +23 dBm of output power at 1 dB gain compression, while requiring 180 mA from a +5V supply. The HMC633LC4 is an ideal driver amplifier for microwave radio applications from 5.5 to 17 GHz and may be biased at +5V, 130 mA to provide 2 dB lower gain with improved PAE. The amplifier's I/Os are DC blocked and matched to 50 Ohms with no external matching required.

Electrical Specifications, $T_A = +25^\circ\text{C}$, $V_{dd_{1-4}} = 5\text{V}$, $I_{dd} = 180\text{mA}$ [1]

Parameter	Min.	Typ.	Max.	Min.	Typ.	Max.	Units	
Frequency Range	5.5 - 9		9 - 17					GHz
Gain	26	30		25	28		dB	
Gain Variation Over Temperature		0.030	0.040		0.030	0.040	dB/ °C	
Input Return Loss		22			17		dB	
Output Return Loss		22			15		dB	
Output Power for 1 dB Compression (P1dB)	20	23		18	21		dBm	
Saturated Output Power (P _{sat})		23.8			22		dBm	
Output Third Order Intercept (IP3)		30			29		dBm	
Noise Figure		10			7		dB	
Supply Current (I _{dd}) (I _{dd} = I _{dd1} + I _{dd2} + I _{dd3} + I _{dd4})		180			180		mA	

[1] Adjust V_{gg} between -2 to 0V to achieve I_{dd} = 180 mA typical.



GaAs PHEMT MMIC DRIVER AMPLIFIER, 5.5 - 17 GHz

Broadband Gain & Return Loss

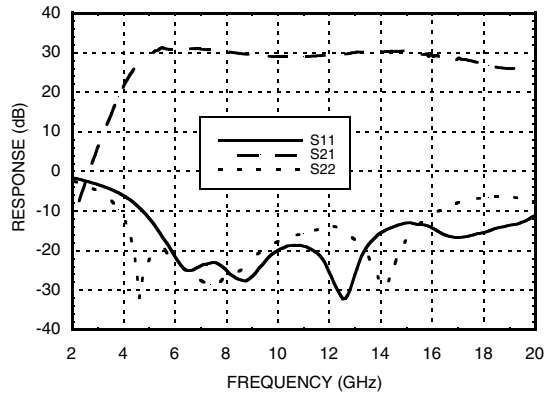

Gain vs. Temperature

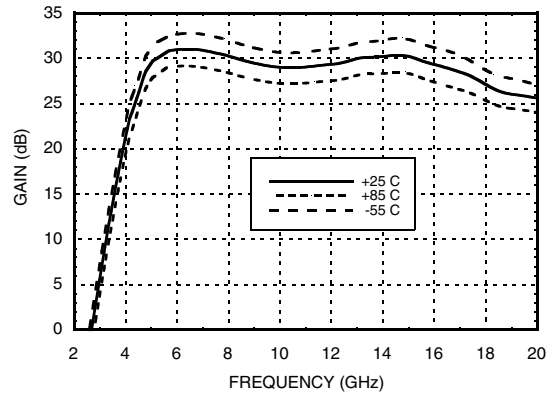

Input Return Loss vs. Temperature

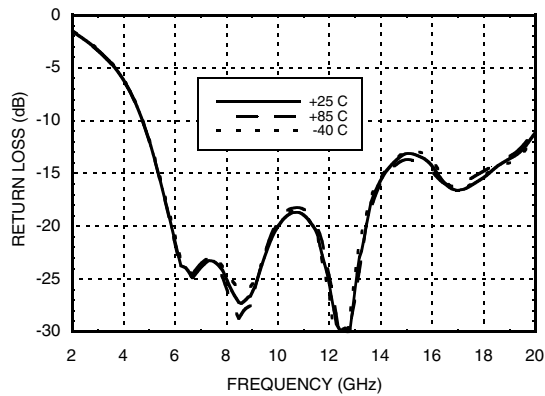

Output Return Loss vs. Temperature

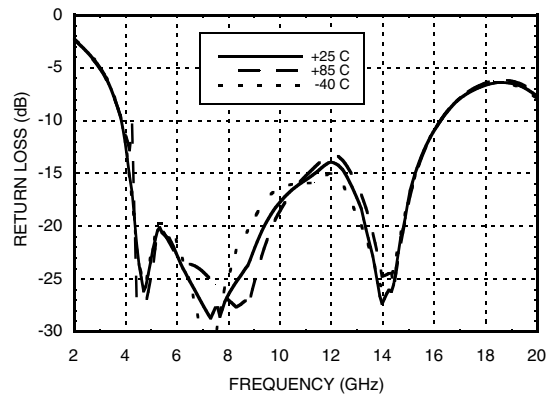

P1dB vs. Temperature

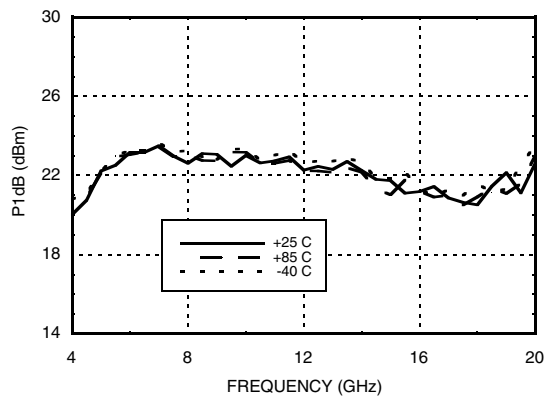

Psat vs. Temperature

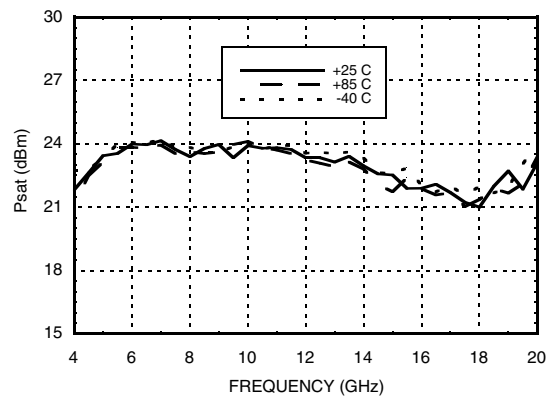

Information furnished by Analog Devices is believed to be accurate and reliable. However, no responsibility is assumed by Analog Devices for its use, nor for any infringements of patents or other rights of third parties that may result from its use. Specifications subject to change without notice. No license is granted by implication or otherwise under any patent or patent rights of Analog Devices. Trademarks and registered trademarks are the property of their respective owners.

For price, delivery, and to place orders: Analog Devices, Inc., One Technology Way, P.O. Box 9106, Norwood, MA 02062-9106 Phone: 781-329-4700 • Order online at www.analog.com Application Support: Phone: 1-800-ANALOG-D



GaAs PHEMT MMIC DRIVER AMPLIFIER, 5.5 - 17 GHz

DRIVER & GAIN BLOCK AMPLIFIERS - SMT

Power Compression @ 11 GHz

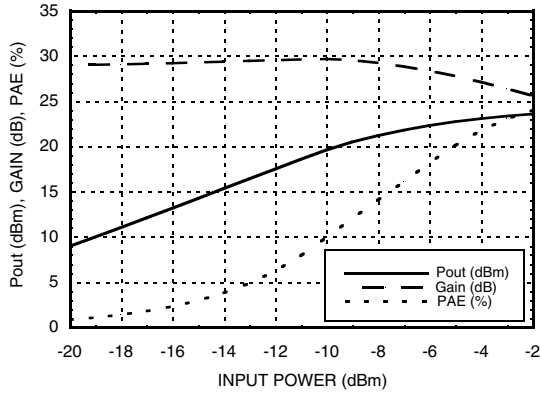

Power Compression @ 17 GHz

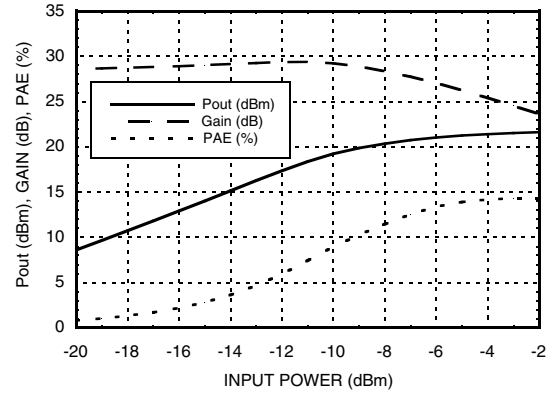

Output IP3 vs. Temperature

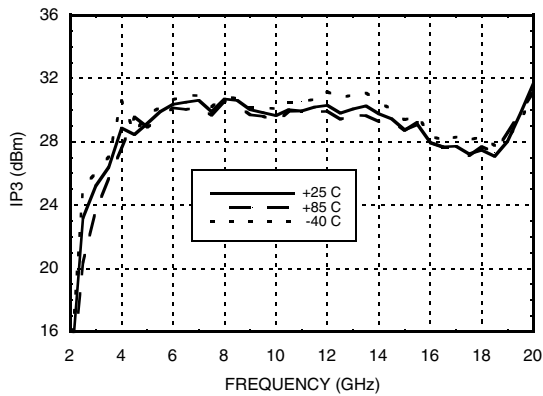

Noise Figure vs. Temperature

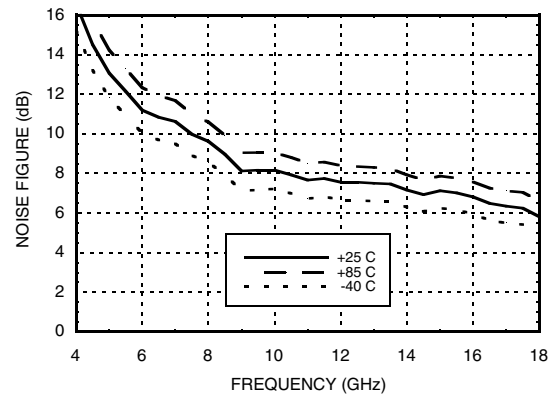

Gain & Power vs. Supply Voltage @ 11 GHz

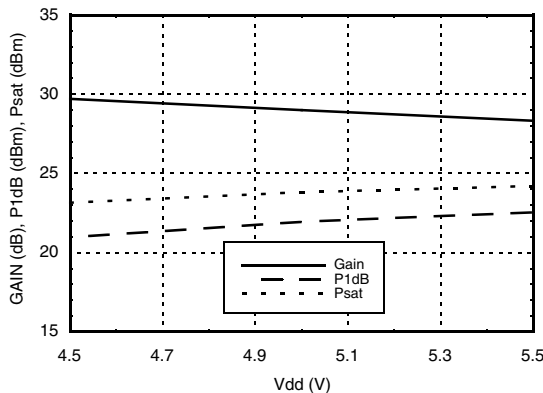

Reverse Isolation vs. Temperature

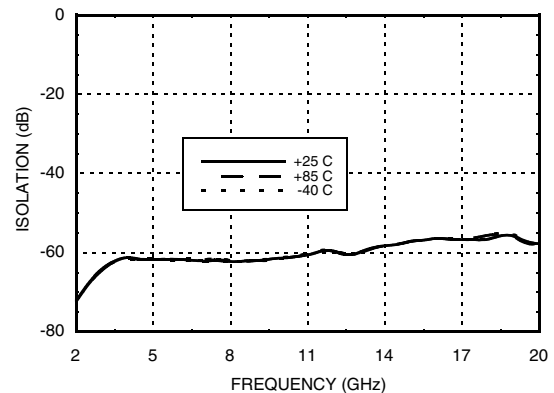

Information furnished by Analog Devices is believed to be accurate and reliable. However, no responsibility is assumed by Analog Devices for its use, nor for any infringements of patents or other rights of third parties that may result from its use. Specifications subject to change without notice. No license is granted by implication or otherwise under any patent or patent rights of Analog Devices. Trademarks and registered trademarks are the property of their respective owners.

For price, delivery, and to place orders: Analog Devices, Inc., One Technology Way, P.O. Box 9106, Norwood, MA 02062-9106 Phone: 781-329-4700 • Order online at www.analog.com Application Support: Phone: 1-800-ANALOG-D



**GaAs PHEMT MMIC DRIVER
AMPLIFIER, 5.5 - 17 GHz**

**Gain, Power & Output IP3
vs. Gate Voltage @ 11 GHz**

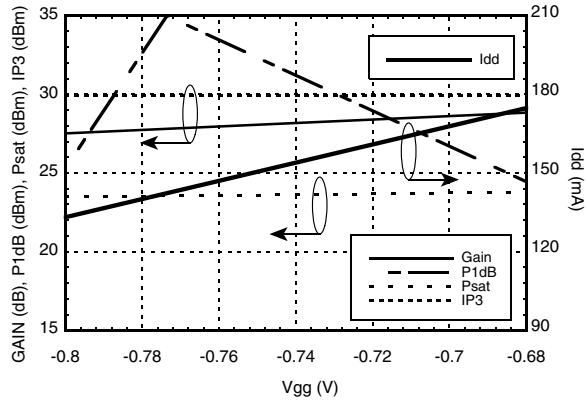

Absolute Maximum Ratings

Drain Bias Voltage (Vdd1, Vdd2, Vdd3, Vdd4)	+5.5V
Gate Bias Voltage (Vgg)	-3 to 0V
RF Input Power (RFIN)(Vdd = +5 Vdc)	+5 dBm
Channel Temperature	175 °C
Continuous P _{diss} (T= 85 °C) (derate 11.08 mW/°C above 85 °C)	0.99 W
Thermal Resistance (channel to package bottom)	90.23 °C/W
Storage Temperature	-65 to +150 °C
Operating Temperature	-40 to +85 °C



**ELECTROSTATIC SENSITIVE DEVICE
OBSERVE HANDLING PRECAUTIONS**

Typical Supply Current vs. Vdd

Vdd (V)	I _{dd} (mA)
4.5	177
5.0	180
5.5	182

Note: Amplifier will operate over full voltage ranges shown above



**GaAs PHEMT MMIC DRIVER
AMPLIFIER, 5.5 - 17 GHz**

Outline Drawing

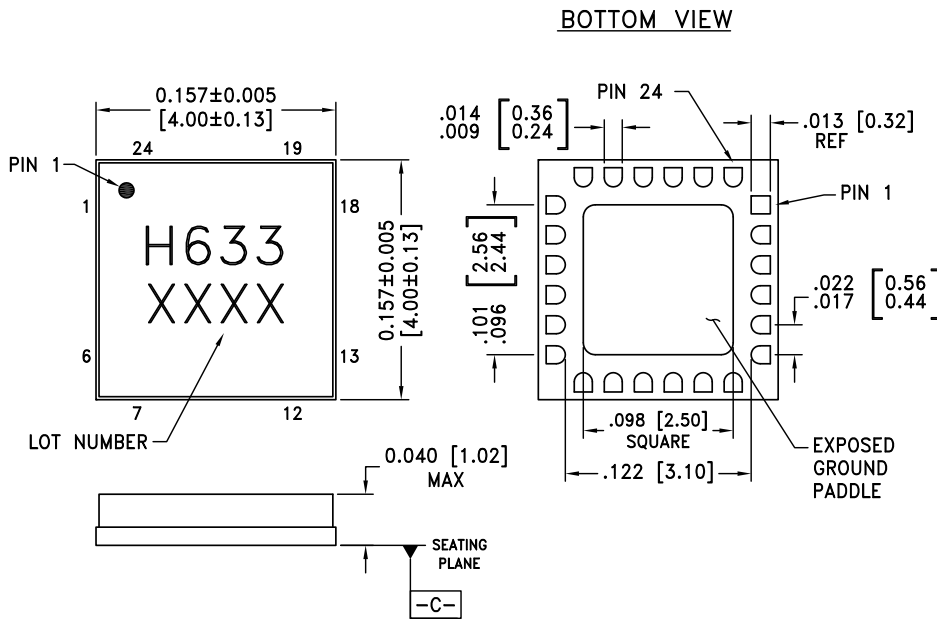

NOTES:

1. PACKAGE BODY MATERIAL: ALUMINA
2. LEAD AND GROUND PADDLE PLATING: 30-80 MICROINCHES GOLD OVER 50 MICROINCHES MINIMUM NICKEL.
3. DIMENSIONS ARE IN INCHES [MILLIMETERS].
4. LEAD SPACING TOLERANCE IS NON-CUMULATIVE.
5. PACKAGE WARP SHALL NOT EXCEED 0.05mm DATUM -C-
6. ALL GROUND LEADS AND GROUND PADDLE MUST BE SOLDERED TO PCB RF GROUND.

Package Information

Part Number	Package Body Material	Lead Finish	MSL Rating	Package Marking ^[2]
HMC633LC4	Alumina, White	Gold over Nickel	MSL3 ^[1]	H633 XXXX

[1] Max peak reflow temperature of 260 °C

[2] 4-Digit lot number XXXX

GaAs PHEMT MMIC DRIVER AMPLIFIER, 5.5 - 17 GHz



Pin Descriptions

Pin Number	Function	Description	Interface Schematic
1, 5 - 8, 11 - 14, 18, 21, 23	N/C	No connection. These pins may be connected to DC/RF ground. Performance will not be affected.	
2, 4, 15, 17	GND	Package Bottom must be connected to RF/DC ground.	
3	RFIN	This pin is AC coupled and matched to 50 Ohms.	
9	Vgg	Gate control for amplifier, please follow "MMIC Amplifier Biasing Procedure" Application Note: See application circuit for required external components.	
16	RFOUT	This pin is AC coupled and matched to 50 Ohms.	
24, 22, 20, 19	Vdd1, Vdd2, Vdd3, Vdd4	Power Supply Voltage for the amplifier. See application circuit for required external components.	

Application Circuit

Component	Value
C1 - C5	100 pF
C6 - C10	1000 pF
C11 - C15	2.2 μF

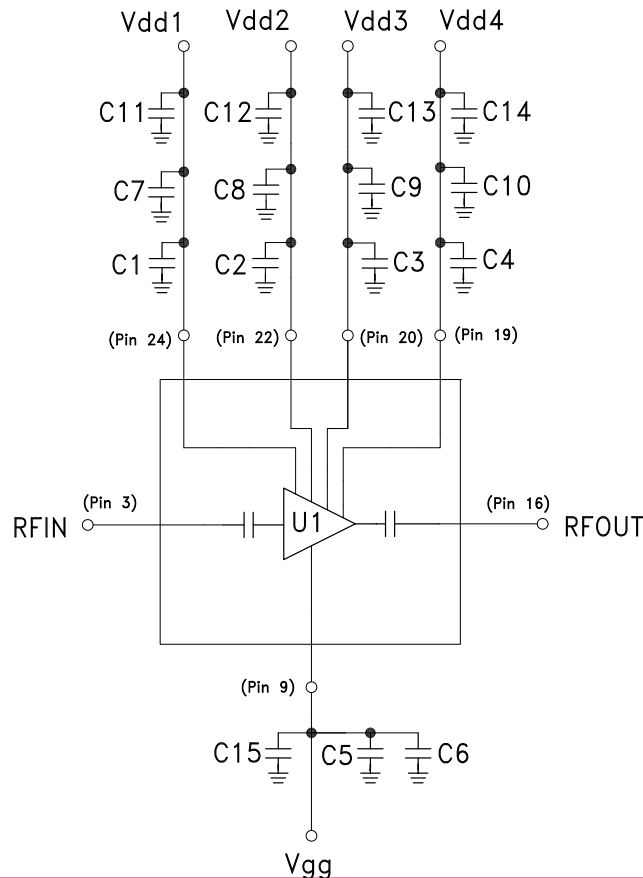

Information furnished by Analog Devices is believed to be accurate and reliable. However, no responsibility is assumed by Analog Devices for its use, nor for any infringements of patents or other rights of third parties that may result from its use. Specifications subject to change without notice. No license is granted by implication or otherwise under any patent or patent rights of Analog Devices. Trademarks and registered trademarks are the property of their respective owners.

For price, delivery, and to place orders: Analog Devices, Inc., One Technology Way, P.O. Box 9106, Norwood, MA 02062-9106 Phone: 781-329-4700 • Order online at www.analog.com Application Support: Phone: 1-800-ANALOG-D



GaAs PHEMT MMIC DRIVER AMPLIFIER, 5.5 - 17 GHz

Evaluation PCB

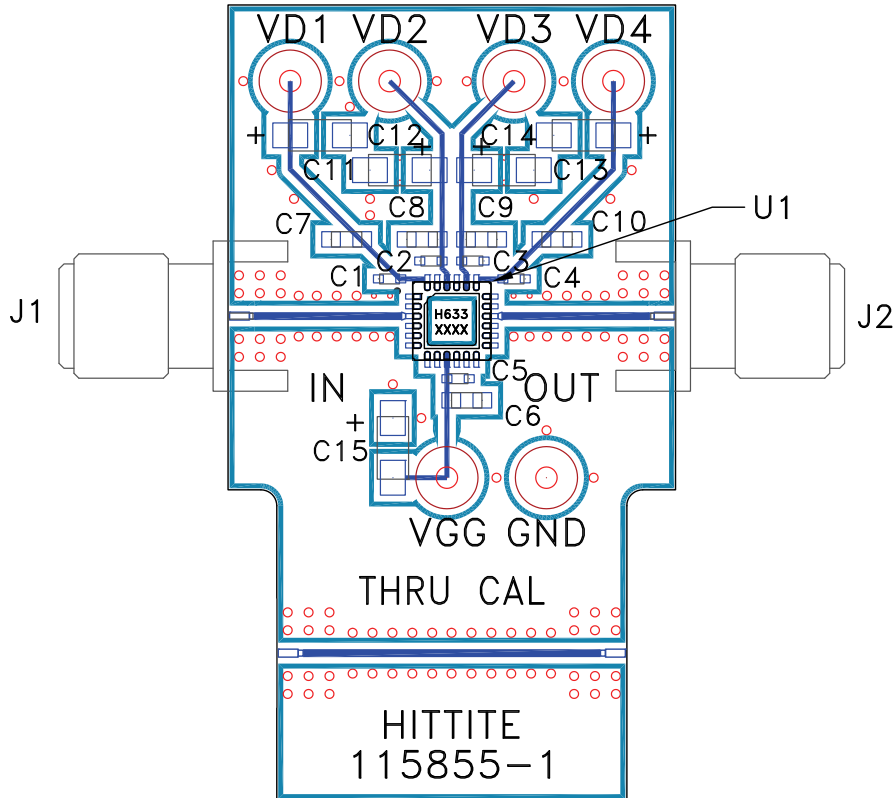

List of Materials for Evaluation PCB 115857 [1]

Item	Description
J1 - J2	2.92 mm PC Mount K-Connector
VD1 - VD4	DC Pin
C1 - C5	100 pF Capacitor, 0402 Pkg.
C6 - C10	1000 pF Capacitor, 0603 Pkg.
C11 - C15	2.2 μF Capacitor, Tantalum
U1	HMC633LC4 Driver Amplifier
PCB [2]	115855 Evaluation PCB



[1] Reference this number when ordering complete evaluation PCB
 [2] Circuit Board Material: Rogers 4350

The circuit board used in the application should use RF circuit design techniques. Signal lines should have 50 Ohm impedance while the package ground leads and exposed paddle should be connected directly to the ground plane similar to that shown. A sufficient number of via holes should be used to connect the top and bottom ground planes. The evaluation board should be mounted to an appropriate heat sink. The evaluation circuit board shown is available from Hittite upon request.

**GaAs PHEMT MMIC DRIVER
AMPLIFIER, 5.5 - 17 GHz**

Looking for pricing, stock, or lifecycle information?

Click below to explore more details on WIN SOURCE:

-  [View HMC633-SX on WIN SOURCE](#)
-  [Analog Devices Inc. Information](#)

Optimize Your Supply Chain with WIN SOURCE Solutions

-  Global Sourcing Solution
-  Obsolete Management
-  Cost Control Management
-  Shortage Management
-  Alternative Solution
-  Excess Inventory Management