

FEATURES

P1dB: 25 dBm (typical) at dc to 30 GHz frequency range
P_{SAT}: 26 dBm (typical) at dc to 30 GHz frequency range
Gain: 11.5 dB (typical)
Output IP3: 33 dBm (typical) at dc to 30 GHz frequency range
Supply voltage: 10 V at 150 mA
50 Ω matched I/O
Die size: 2.89 mm × 1.48 mm × 0.1 mm

APPLICATIONS

Military and space
Test instrumentation

FUNCTIONAL BLOCK DIAGRAM

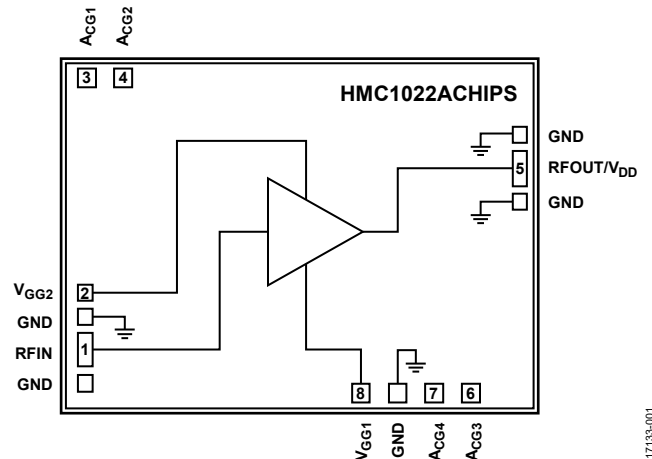

Figure 1.

17133-001

GENERAL DESCRIPTION

The HMC1022ACHIPS is a gallium arsenide (GaAs), pseudomorphic high electron mobility transistor (pHEMT), monolithic microwave integrated circuit (MMIC), distributed power amplifier that operates from dc to 48 GHz. The amplifier provides 11.5 dB of small signal gain, 0.25 W (25 dBm) output power at 1 dB gain compression (P1dB), and a typical output third-order intercept (IP3) of 33 dBm, while requiring 150 mA from a 10 V supply on the V_{DD} pin. Gain flatness is excellent from dc to 48 GHz at ±0.5 dB typical, making the

HMC1022ACHIPS ideal for military, space, and test equipment applications. The HMC1022ACHIPS also features inputs/outputs (I/Os) that are internally matched to 50 Ω, facilitating integration into multichip modules (MCMs). All data is taken with the chip connected via 0.075 mm × 0.025 mm (3 mil × 1 mil) ribbon bonds with a minimal length of 0.31 mm (12 mils).

Rev. 0

[Document Feedback](#)

Information furnished by Analog Devices is believed to be accurate and reliable. However, no responsibility is assumed by Analog Devices for its use, nor for any infringements of patents or other rights of third parties that may result from its use. Specifications subject to change without notice. No license is granted by implication or otherwise under any patent or patent rights of Analog Devices. Trademarks and registered trademarks are the property of their respective owners.

TABLE OF CONTENTS

Features	1	Pin Configuration and Function Descriptions.....	6
Applications.....	1	Interface Schematics	6
Functional Block Diagram	1	Typical Performance Characteristics	7
General Description	1	Theory of Operation	13
Revision History	2	Applications Information	14
Electrical Specifications	3	Biasing Procedures	14
DC to 30 GHz Frequency Range	3	Mounting and Bonding Techniques for Millimeterwave GaAs MMICs.....	15
30 GHz to 40 GHz Frequency Range.....	3	Outline Dimensions	17
40 GHz to 48 GHz Frequency Range.....	4	Ordering Guide	17
Absolute Maximum Ratings.....	5		
Thermal Resistance	5		
ESD Caution.....	5		

REVISION HISTORY

1/2019—Revision 0: Initial Version

ELECTRICAL SPECIFICATIONS

DC TO 30 GHz FREQUENCY RANGE

$T_A = 25^\circ\text{C}$, supply voltage (V_{DD}) = 10 V, gate bias voltage (V_{GG2}) = 4.0 V, and quiescent drain supply current (I_{DQ}) = 150 mA for nominal operation, unless otherwise noted.

Table 1.

Parameter	Symbol	Min	Typ	Max	Unit	Test Conditions/Comments
FREQUENCY RANGE		DC		30	GHz	
GAIN			11.5		dB	
Gain Flatness			± 0.5		dB	
Gain Variation over Temperature			0.015		dB/ $^\circ\text{C}$	
NOISE FIGURE				4.5	dB	
RETURN LOSS						
Input			16		dB	
Output			20		dB	
OUTPUT						
Output Power for 1 dB Compression	P1dB	23	25		dBm	Measurement taken at output power (P_{OUT}) per tone = 16 dBm
Saturated Output Power	P_{SAT}		26		dBm	
Output Third-Order Intercept	IP3		33		dBm	
SUPPLY						
Current	I_{DQ}	125	150		mA	Adjust the gate bias voltage (V_{GG1}) between -2 V up to 0 V to achieve the I_{DQ}
Voltage	V_{DD}	9	10		V	

30 GHz TO 40 GHz FREQUENCY RANGE

$T_A = 25^\circ\text{C}$, $V_{DD} = 10\text{ V}$, $V_{GG2} = 4.0\text{ V}$, and $I_{DQ} = 150\text{ mA}$ for nominal operation, unless otherwise noted.

Table 2.

Parameter	Symbol	Min	Typ	Max	Unit	Test Conditions/Comments
FREQUENCY RANGE		30		40	GHz	
GAIN			11.5		dB	
Gain Flatness			± 0.5		dB	
Gain Variation over Temperature			0.019		dB/ $^\circ\text{C}$	
NOISE FIGURE				5.5	dB	
RETURN LOSS						
Input			22		dB	
Output			12		dB	
OUTPUT						
Output Power for 1 dB Compression	P1dB	19	21		dBm	Measurement taken at P_{OUT} per tone = 16 dBm
Saturated Output Power	P_{SAT}		24.5		dBm	
Output Third-Order Intercept	IP3		29		dBm	
SUPPLY						
Current	I_{DQ}	125	150		mA	Adjust the V_{GG1} between -2 V up to 0 V to achieve the I_{DQ}
Voltage	V_{DD}	9	10		V	

40 GHz TO 48 GHz FREQUENCY RANGE

$T_A = 25^\circ\text{C}$, $V_{DD} = 10\text{ V}$, $V_{GG2} = 4.0\text{ V}$, and $I_{DQ} = 150\text{ mA}$ for nominal operation, unless otherwise noted.

Table 3.

Parameter	Symbol	Min	Typ	Max	Unit	Test Conditions/Comments
FREQUENCY RANGE		40		48	GHz	
GAIN			11.5		dB	
Gain Flatness			± 0.5		dB	
Gain Variation Over Temperature			0.036		dB/ $^\circ\text{C}$	
NOISE FIGURE				7	dB	
RETURN LOSS						
Input			17		dB	
Output			15		dB	
OUTPUT						
Output Power for 1 dB Compression	P1dB	15	17		dBm	
Saturated Output Power	P_{SAT}		21		dBm	
Output Third-Order Intercept	IP3		25		dBm	Measurement taken at P_{OUT} per tone = 16 dBm
SUPPLY						
Current	I_{DQ}	125	150		mA	Adjust the V_{GG1} between -2 V up to 0 V to achieve the I_{DQ}
Voltage	V_{DD}	9	10		V	

ABSOLUTE MAXIMUM RATINGS

Table 4.

Parameter	Rating
V _{DD}	11.0V
Gate Bias	
V _{GG1}	–3.0V to 0V
V _{GG2}	2.5V to (V _{DD} – 5.5V)
Radio Frequency Input Power (RFIN)	22 dBm
Continuous Power Dissipation (P _{DISS}), T = 85°C (Derate 29.9 mW/°C Above 85°C)	2.69 W
Storage Temperature Range	–65°C to +150°C
Operating Temperature Range	–55°C to +85°C
Electrostatic Discharge (ESD) Sensitivity Human Body Model (HBM)	Class 1A (passed 250 V)

Stresses at or above those listed under Absolute Maximum Ratings may cause permanent damage to the product. This is a stress rating only; functional operation of the product at these or any other conditions above those indicated in the operational section of this specification is not implied. Operation beyond the maximum operating conditions for extended periods may affect product reliability.

THERMAL RESISTANCE

Thermal performance is directly linked to system design and operating environment. Careful attention to printed circuit board (PCB) thermal design is required.

θ_{JC} is the channel to case thermal resistance, channel to bottom of die.

Table 5. Thermal Resistance

Package Type	θ_{JC}	Unit
C-8-19	33.5	°C/W

Table 6. Reliability Information

Parameter	Temperature (°C)
Junction Temperature to Maintain 1,000,000 Hour Mean Time to Failure (MTTF)	175
Nominal Junction Temperature (T = 85°C, V _{DD} = 10 V, I _{BQ} = 150 mA)	135.25

ESD CAUTION



ESD (electrostatic discharge) sensitive device. Charged devices and circuit boards can discharge without detection. Although this product features patented or proprietary protection circuitry, damage may occur on devices subjected to high energy ESD. Therefore, proper ESD precautions should be taken to avoid performance degradation or loss of functionality.

PIN CONFIGURATION AND FUNCTION DESCRIPTIONS

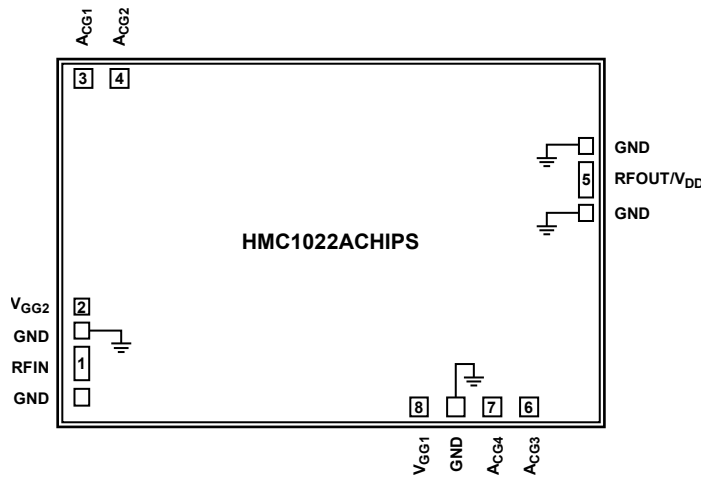

Figure 2. Pad Configuration

17133-002

Table 7. Pad Function Descriptions

Pad No.	Mnemonic	Description
1	RFIN	RF Input Power. This pad is dc-coupled and matched to 50 Ω. Blocking capacitor is required. See Figure 3 for the interface schematic.
2	V _{GG2}	Gate Control 2 for the Amplifier. Attach a bypass capacitor as shown in the typical application circuit (see Figure 47). For nominal operation, it is recommended to apply 4.0 V to V _{GG2} . See Figure 4 for the interface schematic.
3, 4, 6, 7	A _{CG1} , A _{CG2} , A _{CG3} , A _{CG4}	Low Frequency Termination. Attach a bypass capacitor as shown in the typical application circuit (see Figure 47). See Figure 5 and Figure 6 for the interface schematics.
5	RFOUT/V _{DD}	RF Signal Output. Connect the V _{DD} network to provide drain supply current (I _{DD}). See Figure 47 for the typical application circuit. See Figure 5 for the interface schematic.
8	V _{GG1}	Gate Control 1 for the Amplifier. Attach a bypass capacitor as shown in the typical application circuit (see Figure 47). Follow the MMIC Amplifier Biasing Procedure application note. See Figure 7 for the interface schematic.
Die Bottom	GND	Ground. Die bottom must be connected to RF and dc ground. See Figure 8 for the interface schematic.

INTERFACE SCHEMATICS

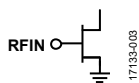

Figure 3. RFIN Interface Schematic

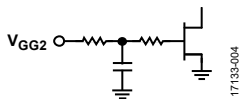

Figure 4. V_{GG2} Interface Schematic

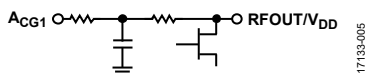

Figure 5. A_{CG1} and RFOUT/V_{DD} Interface Schematic

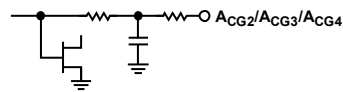

Figure 6. A_{CG2}, A_{CG3}, and A_{CG4} Interface Schematic

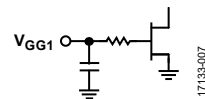

Figure 7. V_{GG1} Interface Schematic



Figure 8. GND Interface Schematic

TYPICAL PERFORMANCE CHARACTERISTICS

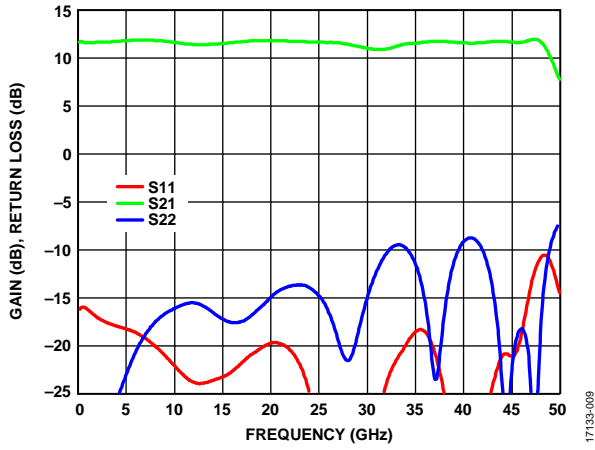

Figure 9. Gain and Return Loss vs. Frequency

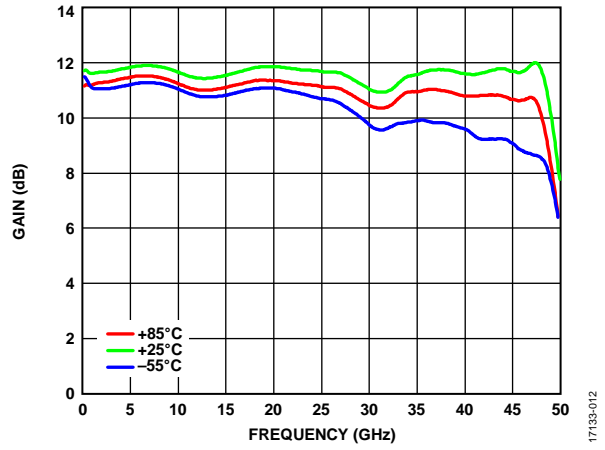

Figure 12. Gain vs. Frequency for Various Temperatures

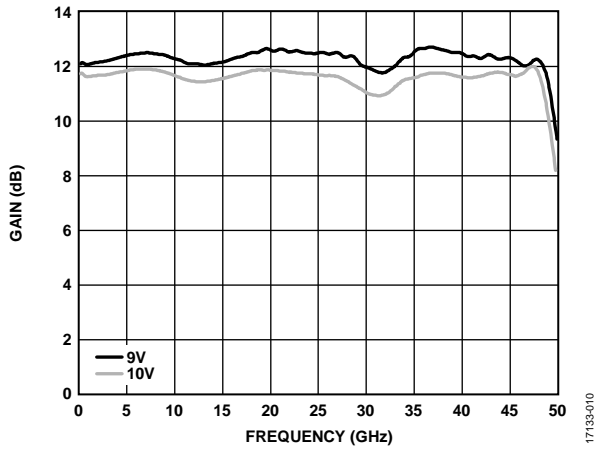

Figure 10. Gain vs. Frequency for Various V_{DD} , for $V_{DD} = 10\text{ V}$, $V_{GG2} = 4.0\text{ V}$ and $I_{DD} = 150\text{ mA}$, and for $V_{DD} = 9\text{ V}$, $V_{GG2} = 3.0\text{ V}$ and $I_{DD} = 150\text{ mA}$

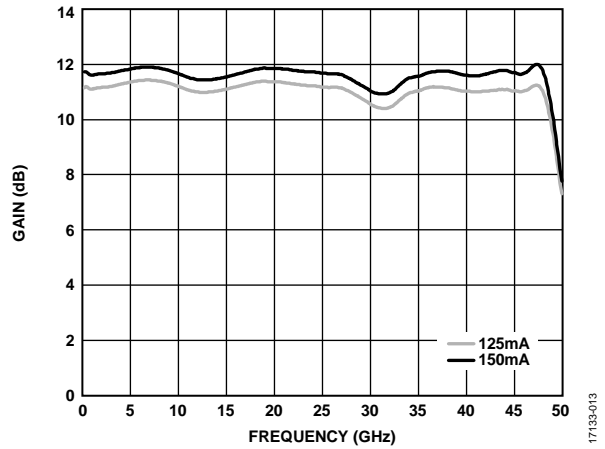

Figure 13. Gain vs. Frequency for Various I_{DD}

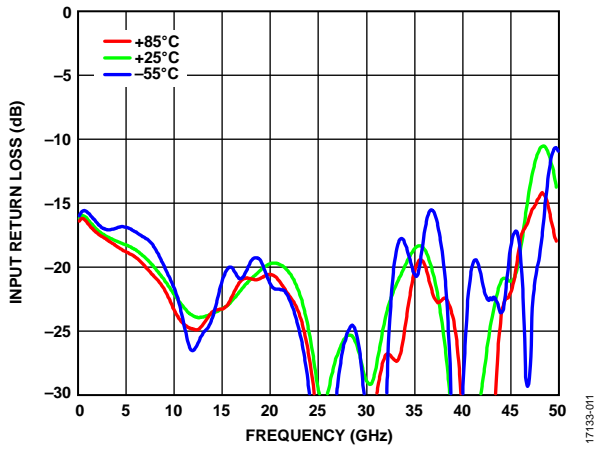

Figure 11. Input Return Loss vs. Frequency for Various Temperatures

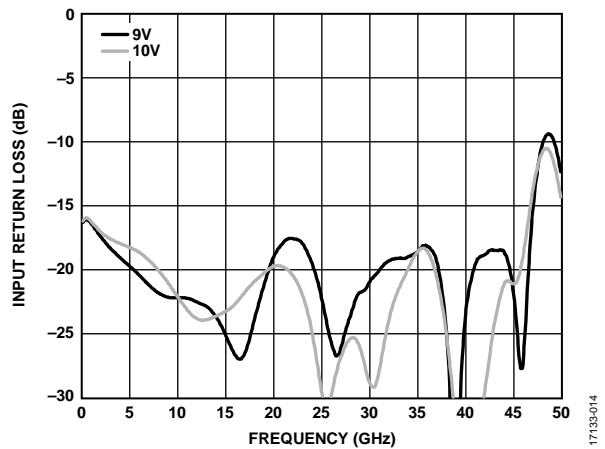

Figure 14. Input Return Loss vs. Frequency for Various V_{DD} , for $V_{DD} = 10\text{ V}$, $V_{GG2} = 4.0\text{ V}$ and $I_{DD} = 150\text{ mA}$, and for $V_{DD} = 9\text{ V}$, $V_{GG2} = 3.0\text{ V}$ and $I_{DD} = 150\text{ mA}$

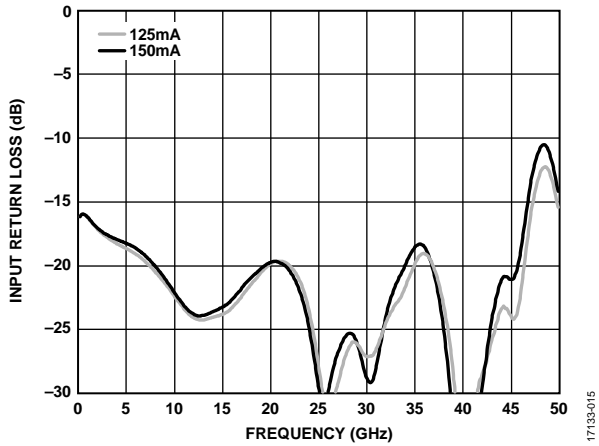

Figure 15. Input Return Loss vs. Frequency for Various I_{DD}

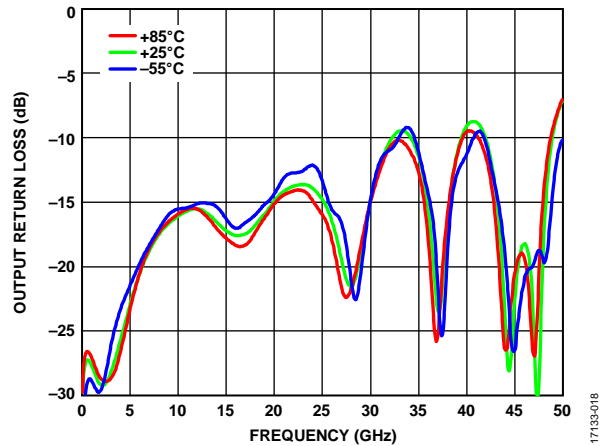

Figure 18. Output Return Loss vs. Frequency for Various Temperatures

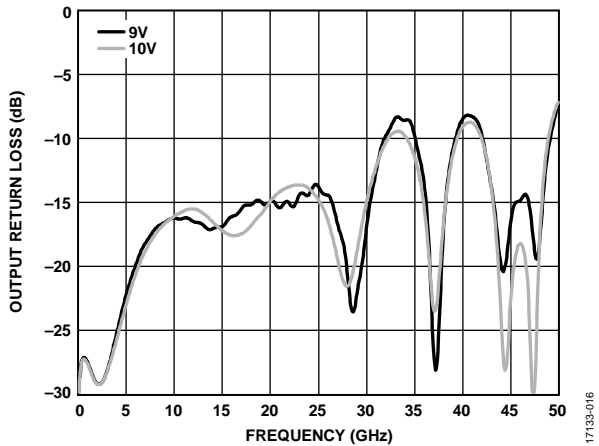

Figure 16. Output Return Loss vs. Frequency for Various V_{DD}

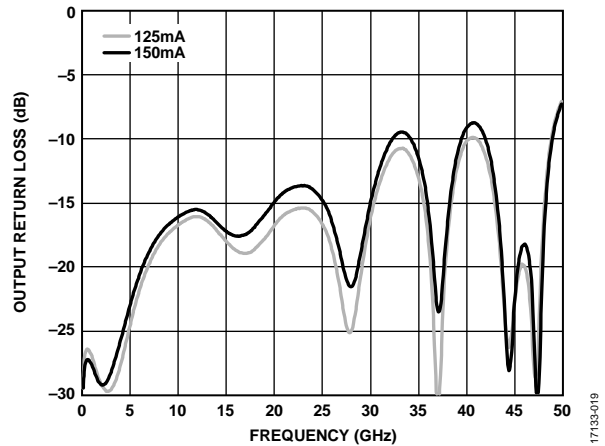

Figure 19. Output Return Loss vs. Frequency for Various I_{DD}

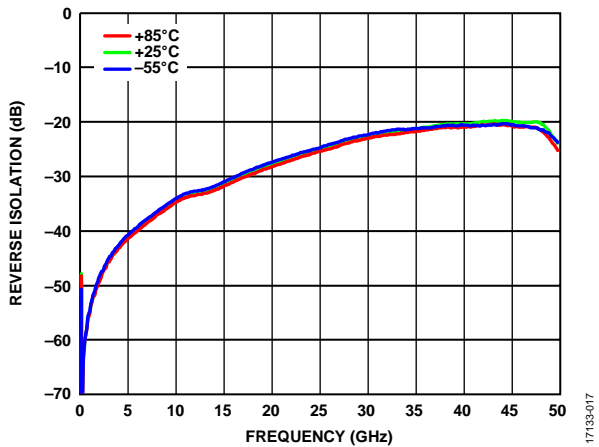

Figure 17. Reverse Isolation vs. Frequency for Various Temperatures

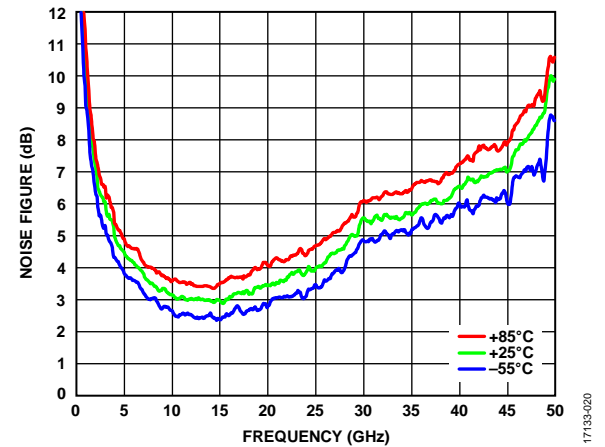

Figure 20. Noise Figure vs. Frequency for Various Temperatures

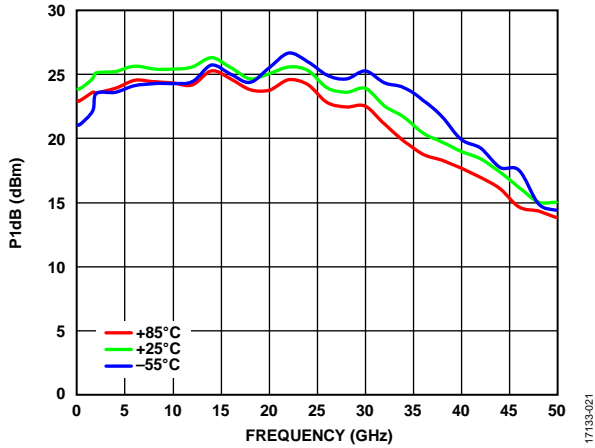

Figure 21. P1dB vs. Frequency for Various Temperatures

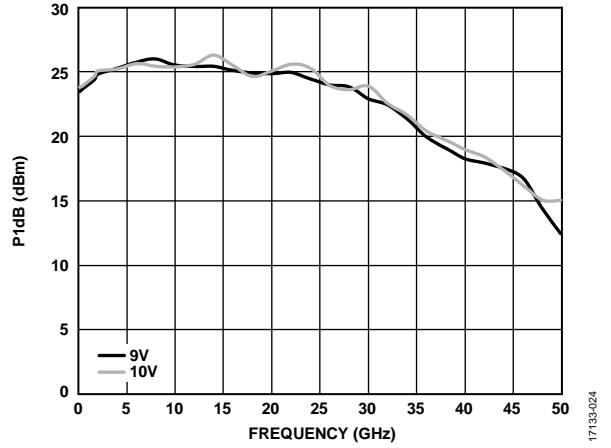

Figure 24. P1dB vs. Frequency for Various V_{DD} , for $V_{DD} = 10\text{ V}$, $V_{GG2} = 4.0\text{ V}$ and $I_{DD} = 150\text{ mA}$, and for $V_{DD} = 9\text{ V}$, $V_{GG2} = 3.0\text{ V}$ and $I_{DD} = 150\text{ mA}$

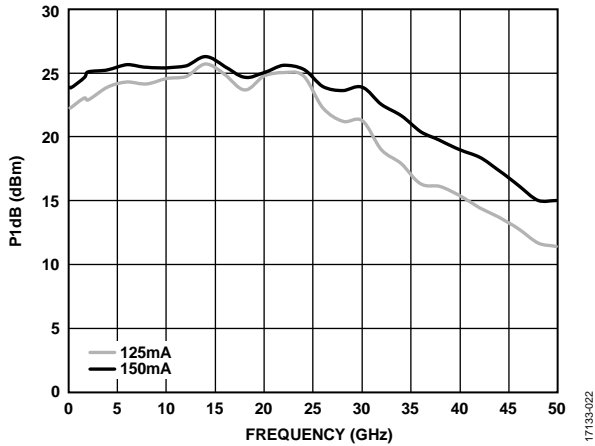

Figure 22. P1dB vs. Frequency for Various I_{DD}

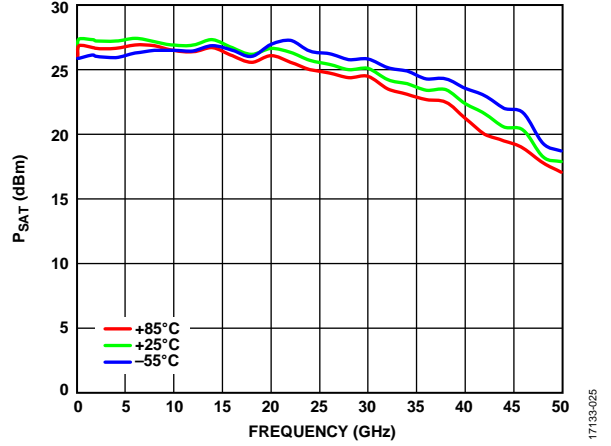

Figure 25. P_{SAT} vs. Frequency for Various Temperatures

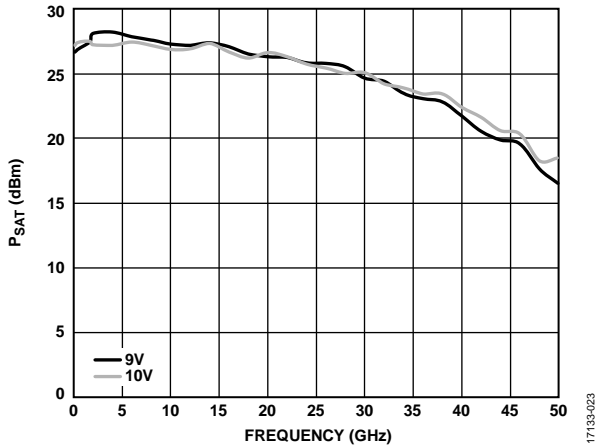

Figure 23. P_{SAT} vs. Frequency for Various V_{DD} , for $V_{DD} = 10\text{ V}$, $V_{GG2} = 4.0\text{ V}$ and $I_{DD} = 150\text{ mA}$, and for $V_{DD} = 9\text{ V}$, $V_{GG2} = 3.0\text{ V}$ and $I_{DD} = 150\text{ mA}$

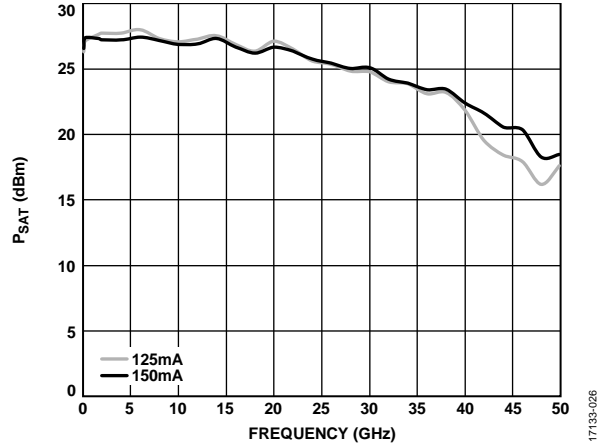

Figure 26. P_{SAT} vs. Frequency for Various I_{DD}

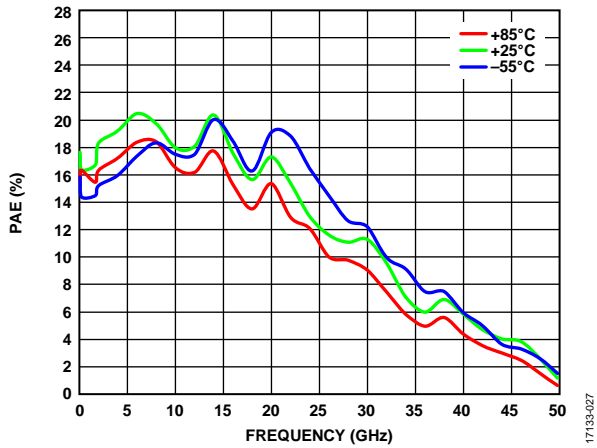

Figure 27. Power Added Efficiency (PAE) vs. Frequency for Various Temperatures, PAE Measured at P_{SAT}

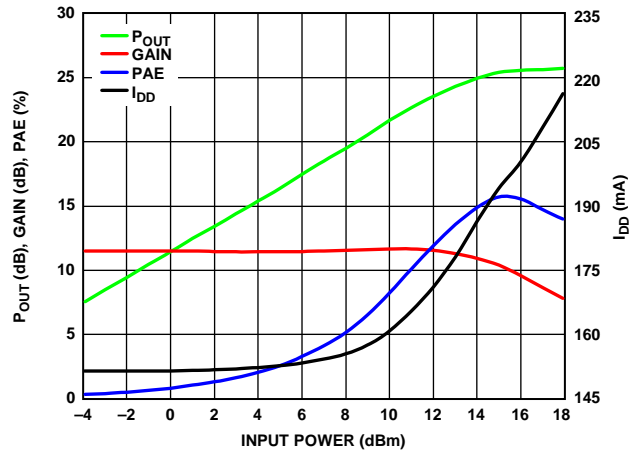

Figure 30. P_{OUT} , Gain, PAE, and I_{DD} vs. Input Power, Frequency = 24 GHz

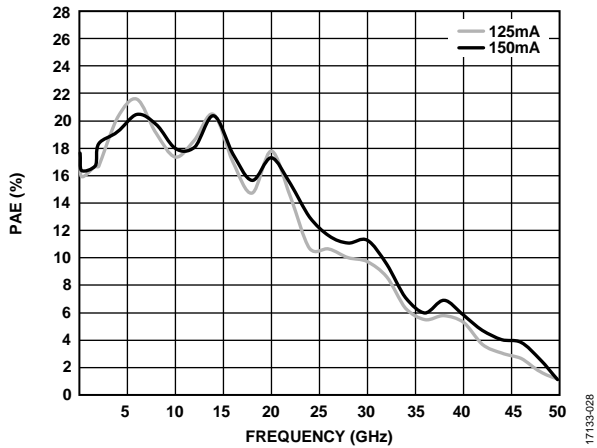

Figure 28. PAE vs. Frequency for Various I_{DD}

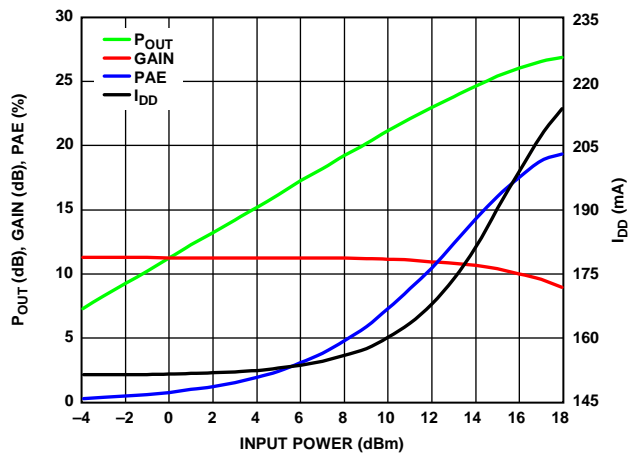

Figure 31. P_{OUT} , Gain, PAE, and I_{DD} vs. Input Power, Frequency = 12 GHz

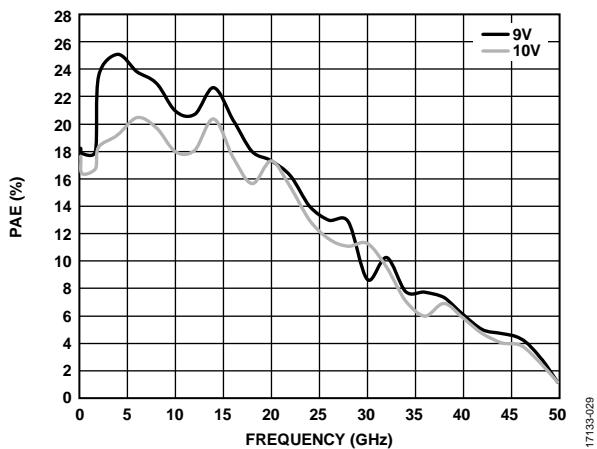

Figure 29. PAE vs. Frequency for Various V_{DD} , PAE Measured at P_{SAT} , for $V_{DD} = 10V$, $V_{GG2} = 4.0V$ and $I_{DD} = 150mA$, and for $V_{DD} = 9V$, $V_{GG2} = 3.0V$ and $I_{DD} = 150mA$

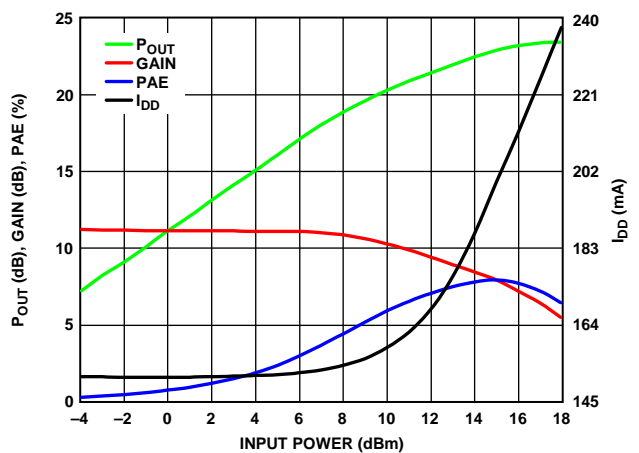

Figure 32. P_{OUT} , Gain, PAE, and I_{DD} vs. Input Power, Frequency = 36 GHz

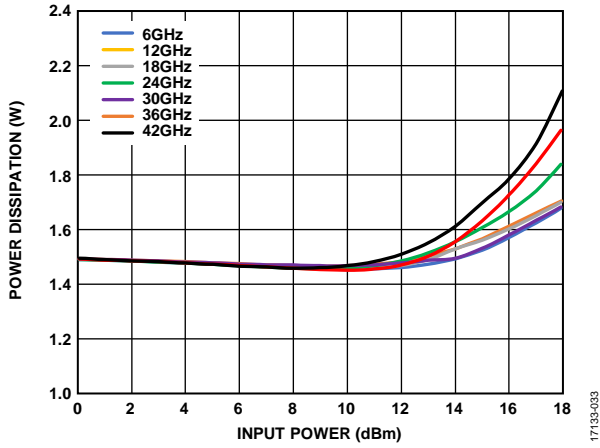

Figure 33. Power Dissipation vs. Input Power, $T_A = 85^\circ\text{C}$

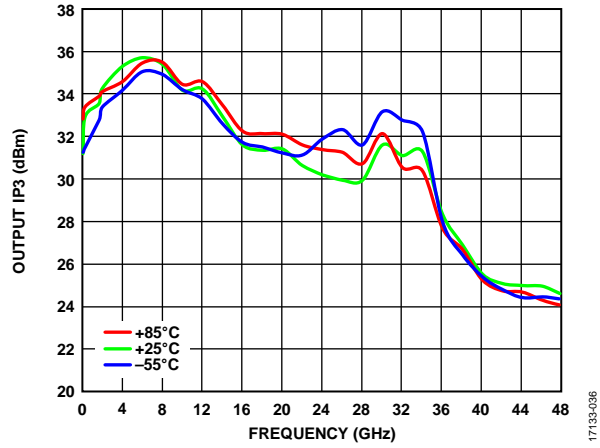

Figure 36. Output IP3 vs. Frequency for Various Temperatures

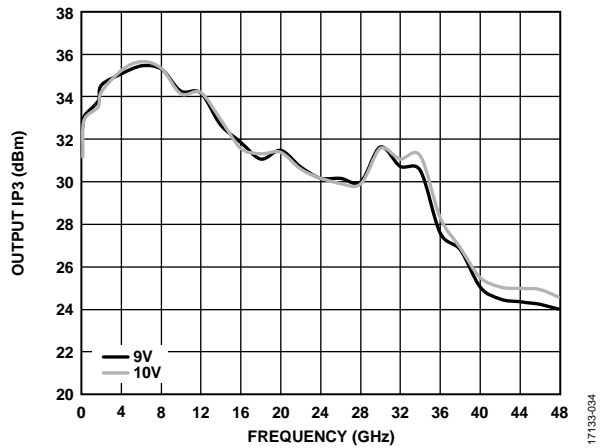

Figure 34. Output IP3 vs. Frequency for Various V_{DD} , P_{OUT} per Tone = 16 dBm, for $V_{DD} = 10\text{ V}$, $V_{GG2} = 4.0\text{ V}$ and $I_{DD} = 150\text{ mA}$, and for $V_{DD} = 9\text{ V}$, $V_{GG2} = 3.0\text{ V}$ and $I_{DD} = 150\text{ mA}$

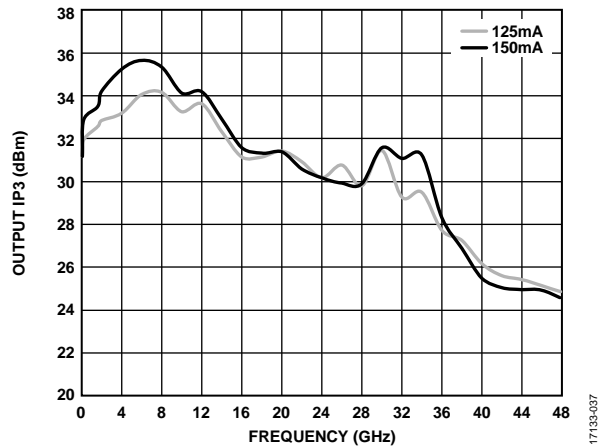

Figure 37. Output IP3 vs. Frequency for Various I_{DD} , P_{OUT} per Tone = 16 dBm

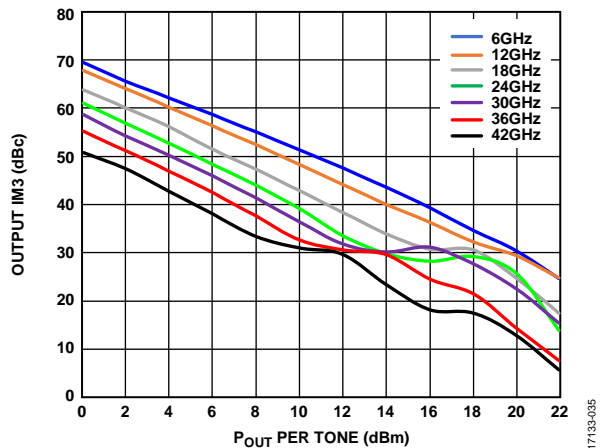

Figure 35. Output Third-Order Intermodulation (IM3) vs. P_{OUT} per Tone for Various Frequencies, $V_{DD} = 10.0\text{ V}$

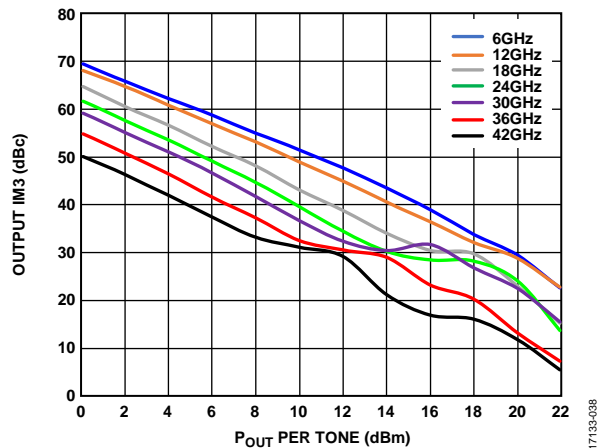

Figure 38. Output IM3 vs. P_{OUT} per Tone for Various Frequencies, $V_{DD} = 9.0\text{ V}$

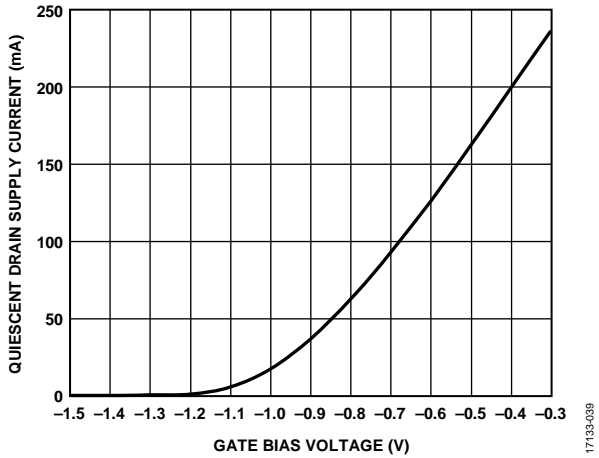

Figure 39. Quiescent Drain Supply Current vs. Gate Bias Voltage

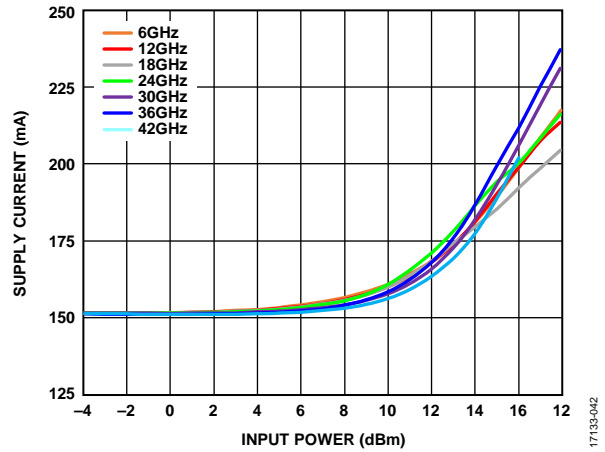

Figure 42. Supply Current vs. Input Power over Frequencies

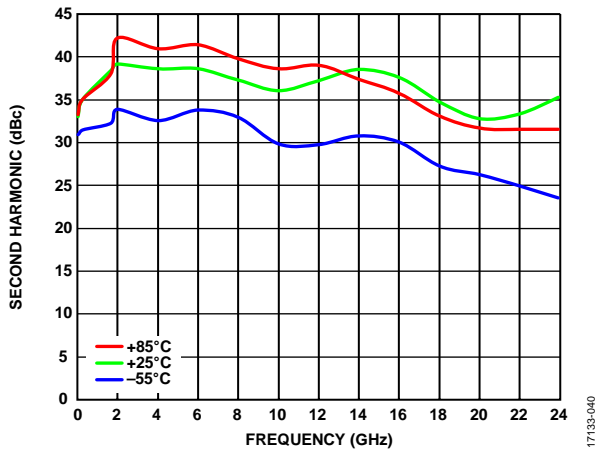

Figure 40. Second Harmonic vs. Frequency over Temperatures

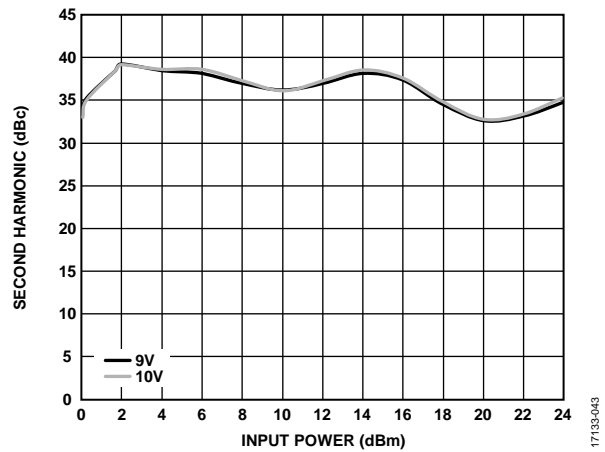

Figure 43. Second Harmonic vs. Input Power over V_{DD}

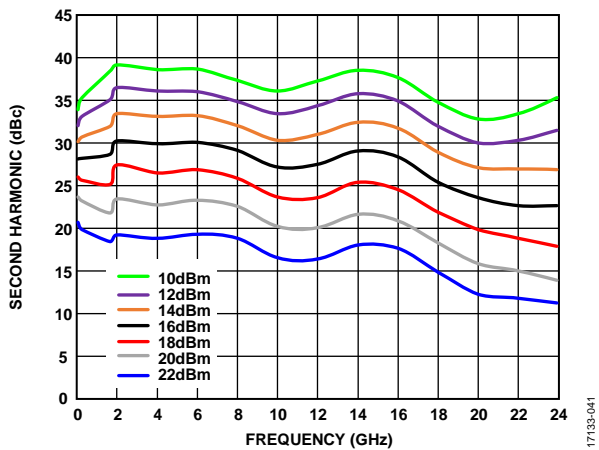

Figure 41. Second Harmonic vs. Frequency over Output Power

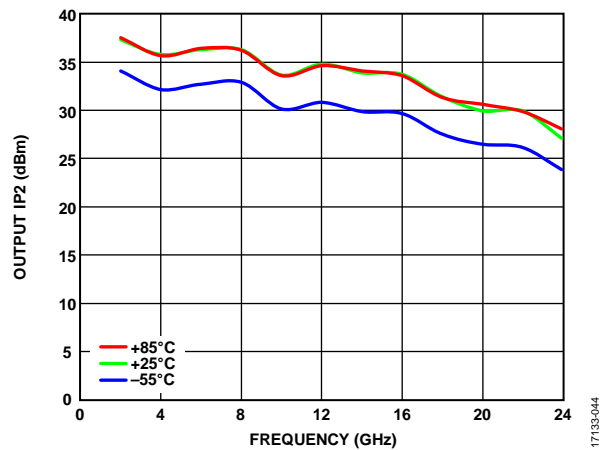

Figure 44. Output Second-Order Intercept (IP₂) vs. Frequency, P_{OUT} = 16 dBm

THEORY OF OPERATION

The HMC1022ACHIPS is a GaAs, pHEMT, MMIC, cascaded, distributed power amplifier. The cascaded distributed architecture uses a fundamental cell consisting of a stack of two field effect transistors (FETs) connected from source to drain. The basic schematic for a fundamental cell is shown in Figure 45. The fundamental cell is duplicated several times, with transmission lines connecting the drains of the top devices and the gates of the bottom devices, respectively. Additional circuit design techniques around each cell optimize the overall response. The major benefit of this architecture is that acceptable gain is maintained across a bandwidth that is far greater than what is typically provided by a single instance of the fundamental cell.

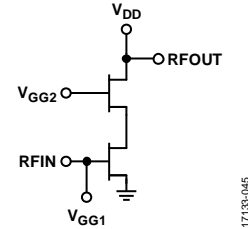

Figure 45. Fundamental Cell Schematic

To obtain the best performance from the HMC1022ACHIPS and to avoid damaging the device, follow the recommended biasing sequences described in the Biasing Procedures section.

APPLICATIONS INFORMATION

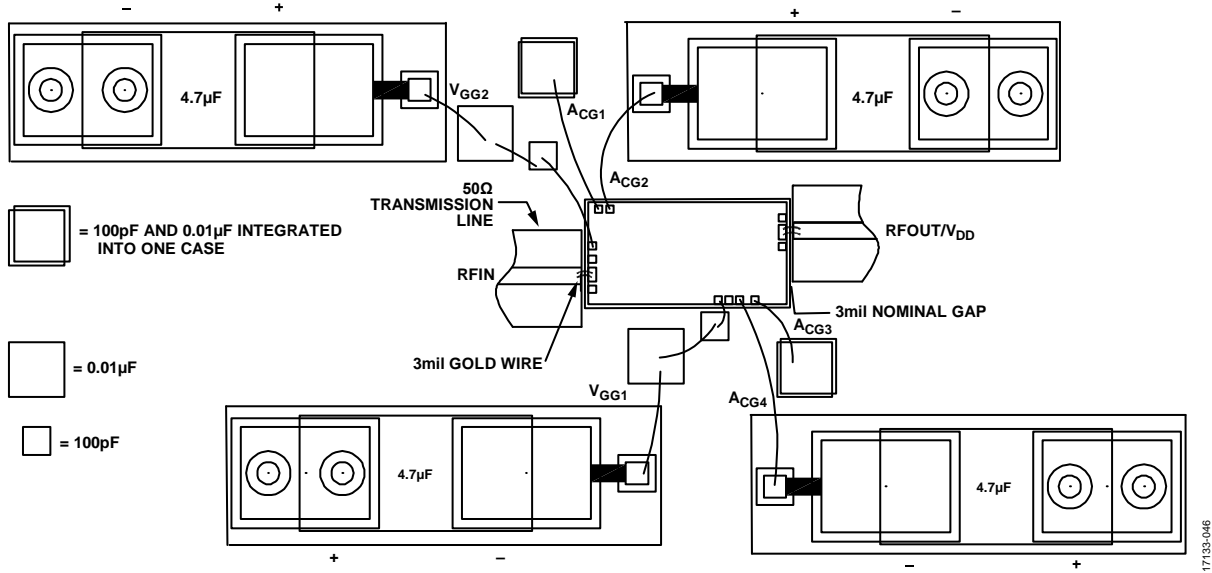
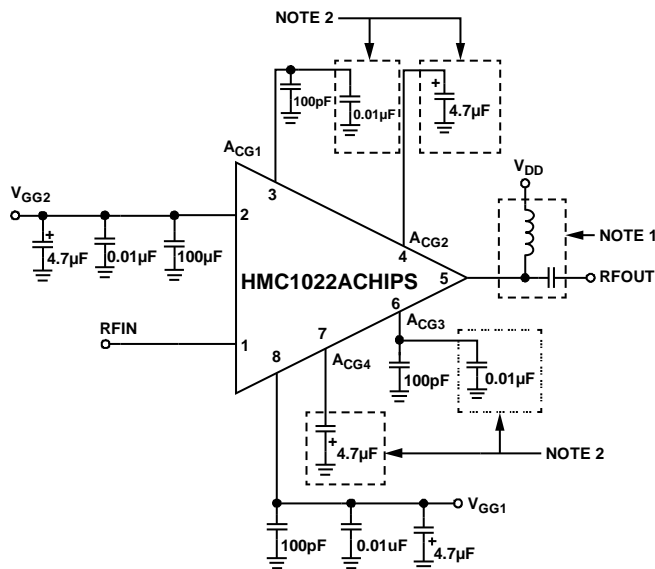

Figure 46. Assembly Diagram



- NOTES
1. SUPPLY VOLTAGE (V_{DD}) MUST BE APPLIED THROUGH A BROADBAND BIAS TEE WITH LOW SERIES RESISTANCE AND IS CAPABLE OF PROVIDING 500mA.
 2. OPTIONAL CAPACITORS TO BE USED IF DEVICE IS TO BE OPERATED BELOW 200MHz.

Figure 47. Typical Application Circuit

BIASING PROCEDURES

Capacitive bypassing is required for both V_{GG1} and V_{GG2} , as shown in Figure 47. The capacitors to ground required for the $ACG1$ through $ACG4$ pads act as low frequency terminations. This bypassing scheme helps flatten the overall frequency response by diminishing the gain at low frequencies.

The recommended biasing sequence during power-up is as follows:

1. Connect to ground.
2. Set V_{GG1} to -2 V to pinch off the drain current.
3. Set V_{DD} to 10 V (the drain current is pinched off).
4. Set V_{GG2} to 4 V (the drain current is pinched off).
5. Adjust V_{GG1} in a positive direction until an I_{DQ} of 150 mA is obtained.
6. Apply the RF signal.

The recommended biasing sequence during power-down is as follows:

1. Turn off the RF signal.
2. Set V_{GG1} to -2 V to pinch off the drain current.
3. Set V_{GG2} to 0 V.
4. Set V_{DD} to 0 V.
5. Set V_{GG1} to 0 V.

All measurements for the HMC1022ACHIPS are taken using the typical application circuit (see Figure 47) configured as shown in Figure 46. The bias conditions shown in the Electrical Specifications section are the operating points recommended to optimize the overall performance. Unless otherwise noted, the data shown is taken using the recommended bias conditions. Operation of the HMC1022ACHIPS at different bias conditions may provide performance that differs from what is shown in the Typical Performance Characteristics section.

MOUNTING AND BONDING TECHNIQUES FOR MILLIMETERWAVE GaAs MMICs

Attach the die directly to the ground plane eutectically or with conductive epoxy (see the Handling Precautions section, the Mounting section, and the Wire Bonding section).

Microstrip, 50Ω , transmission lines on 0.127 mm (0.005 ") thick alumina thin film substrates are recommended for bringing the radio frequency to and from the chip (see Figure 48). When using 0.254 mm (0.010 ") thick alumina thin film substrates, raise the die 0.150 mm (0.005 ") to ensure that the surface of the die is coplanar with the surface of the substrate. One way to accomplish this is to attach the 0.102 mm (0.004 ") thick die to a 0.150 mm (0.005 ") thick molybdenum (Mo) heat spreader (moly tab), which is then attached to the ground plane (see Figure 49).

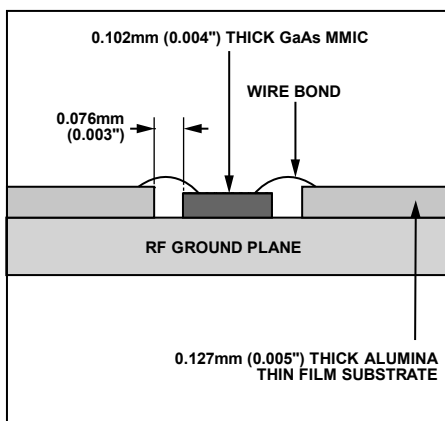

Figure 48. Die Without the Moly Tab

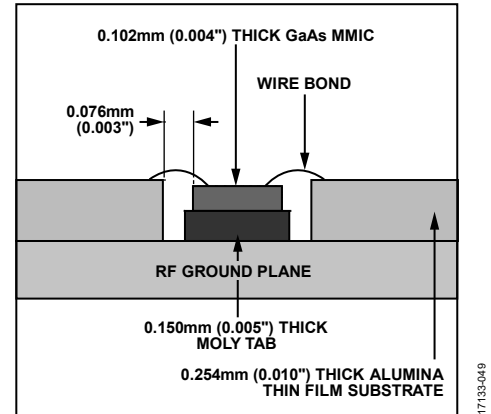

Figure 49. Die With the Moly Tab

Place the microstrip substrates as close to the die as possible to minimize bond wire length. Typical die to substrate spacing is 0.076 mm to 0.152 mm (0.003 " to 0.006 ").

Handling Precautions

To avoid permanent damage, follow these storage, cleanliness, static sensitivity, transient, and general handling precautions:

- Place all bare die in either waffle or gel-based ESD protective containers and then seal the die in an ESD protective bag for shipment. Once the sealed ESD protective bag is opened, store all die in a dry nitrogen environment.
- Handle the chips in a clean environment. Do not attempt to clean the chip using liquid cleaning systems.
- Follow ESD precautions to protect against ESD strikes.
- While bias is applied, suppress instrument and bias supply transients. Use shielded signal and bias cables to minimize inductive pick up.
- Handle the chip along the edges with a vacuum collet or with a sharp pair of bent tweezers. The surface of the chip may have fragile air bridges and must not be touched with vacuum collet, tweezers, or fingers.

Mounting

The chip is back metallized and can be die mounted with gold (Au)/tin (Sn) eutectic preforms or with electrically conductive epoxy. Ensure that the mounting surface is clean and flat.

When attaching eutectic die, an 80 Au/20 Sn preform is recommended with a work surface temperature of 255°C and a tool temperature of 265°C . When hot 90 nitrogen (N)/10 hydrogen (H) gas is applied, ensure that the tool tip temperature is 290°C . Do not expose the chip to a temperature greater than 320°C for more than 20 seconds. For attachment, no more than three seconds of scrubbing is required.

When attaching epoxy die, apply a minimum amount of epoxy to the mounting surface so that a thin epoxy fillet is observed around the perimeter of the chip once it is placed into position. Cure epoxy per the schedule of the manufacturer.

Wire Bonding

RF bonds made with two 1 mil wires are recommended. Ensure that these bonds are thermosonically bonded with a force of 40 grams to 60 grams. DC bonds of a 0.001" (0.025 mm) diameter, thermosonically bonded, are recommended. Make

ball bonds with a force of 40 grams to 50 grams and wedge bonds with a force of 18 grams to 22 grams. Make all bonds with a nominal stage temperature of 150°C. Apply a minimum amount of ultrasonic energy to achieve reliable bonds. Make all bonds as short as possible, less than 12 mils (0.31 mm).

OUTLINE DIMENSIONS

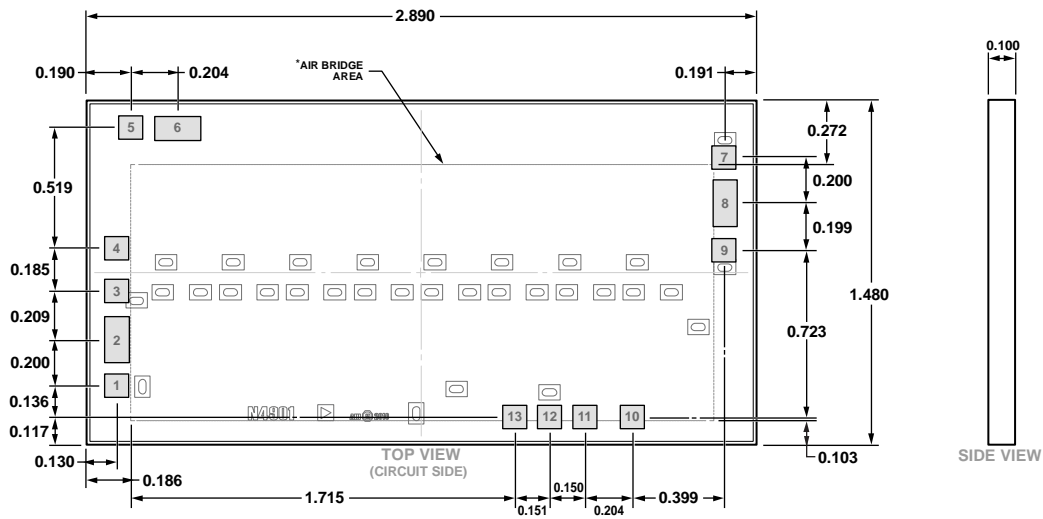

*This die utilizes fragile air bridges. Any pickup tools used must not contact this area.

Figure 50. 8-Pad Bare Die [CHIP]
(C-8-19)
Dimensions shown in millimeters

12-07-2018-A

ORDERING GUIDE

Model ¹	Temperature Range	Package Description	Package Option
HMC1022ACHIPS	-55°C to +85°C	8-Pad Bare Die [CHIP]	C-8-19
HMC1022A-SX	-55°C to +85°C	8-Pad Bare Die [CHIP]	C-8-19

¹ The HMC1022ACHIPS model is RoHS compliant.

Looking for pricing, stock, or lifecycle information?

Click below to explore more details on WIN SOURCE:

 [View HMC1022A-SX on WIN SOURCE](#)

 [Analog Devices Inc. Information](#)

Optimize Your Supply Chain with WIN SOURCE Solutions

-  Global Sourcing Solution
-  Obsolete Management
-  Cost Control Management
-  Shortage Management
-  Alternative Solution
-  Excess Inventory Management