

Product Overview

The QPA9510 is a high-power, high-gain, high-efficiency power amplifier. The device is manufactured with Qorvo's advanced GaAs process. The amplifier provides 34dB of max gain and able to achieve +35dBm of P1dB along with flexibility in bias settings.

QPA9510 is designed for use as the final RF amplifier in GSM hand-held equipment in 900 MHz band and other applications in the UHF bands. An analog on-board power controller provides over 70 dB range of gain adjustment. This control also allows for power down with a voltage equal to the logic "Low" to set the device in standby mode.

The QPA9510 is tunable over any sub-bands in the operating range to optimize performance. The amplifiers sit in a 3mmx3mm compact QFN package.

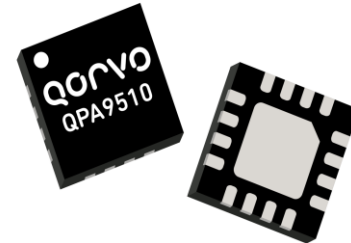

16 Pad 3 x 3 mm QFN Package

Key Features

GSM:

- 100 – 1000 MHz Operating Frequency Range
- +2.8 to +3.6V Single Supply
- 34 dB Max Gain with Analog Gain Control
- 55% Efficiency
- Achieves +35 dBm P1dB
- Supports GSM and E-GSM
- 3 x 3 mm QFN Package

Functional Block Diagram

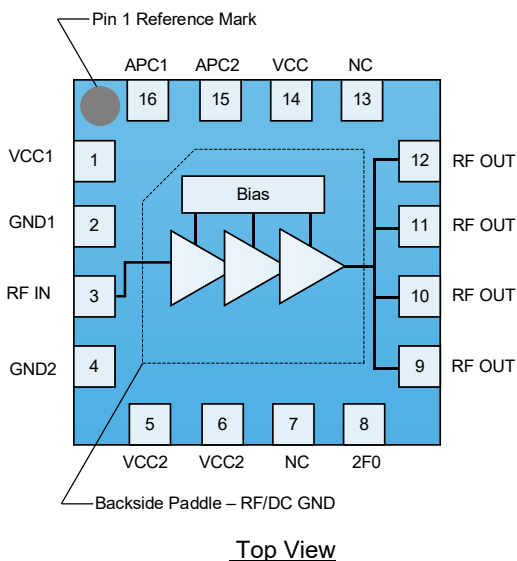

Applications

- FM Radio Applications: 865 MHz to 928 MHz
- 3V GSM Cellular Handsets
- GPRS Compatible
- UHF Applications

Ordering Information

Part No.	Description
QPA9510TR7	2,500 pieces on a 7" reel (standard)
QPA9510EVB01	GSM900 Fully Tested Evaluation Board

Absolute Maximum Ratings

Parameter	Rating
Storage Temperature	-55 °C to 150 °C
Device Voltage (VCC, VCC1, VCC2)	-0.5V to +6.0V
Control Voltage (V _{APC1} , V _{APC2})	-0.5V to +3.0V
Device Current (I _{CC1} , I _{CC2} , I _{CC3})	2400 mA
RF Input Power, 50Ω, DC 50%	+13 dBm

Exceeding any one or a combination of the Absolute Maximum Rating conditions may cause permanent damage to the device. Extended application of Absolute Maximum Rating conditions to the device may reduce device reliability.

Recommended Operating Conditions

Parameter	Min	Typ	Max	Units
Device Voltage (VCC, VCC1, VCC2)		+3.5		
	+2.7		+4.8 ⁽¹⁾⁽²⁾	V
			+5.0 ⁽¹⁾⁽²⁾	V
T _{CASE}	-40		+85	°C
T _j for 10 ⁶ hours MTTF			+175	°C

Notes:

1. P_{out} < TBD dBm
2. With maximum output load VSWR TBD

Electrical specifications are measured at specified test conditions. Specifications are not guaranteed over all recommended operating conditions.

Switch Control Logic–Truth Table

Parameter	APC1	APC2
Standby	0 V	0 V
Operating Mode	2.8 V	2.8 V

Electrical Specifications

Parameter	Conditions ⁽¹⁾	Min	Typ	Max	Units
Operational Frequency Range	Tune for 900MHz EVB	880		915	MHz
Gain	$P_{IN} = -20$ dBm, Small Signal at 900MHz		33.8		dB
Maximum Output Power			35.4		dBm
Efficiency	At Maximum Output Power		55.2		%
Forward Isolation	Standby Mode V_{APC1} and $V_{APC2} = 0.3$ V, $P_{IN} = +9.5$ dBm		-43.6		dBm
Second Harmonic	$P_{IN} = +9.5$ dBm		-28.5		dBm
Third Harmonic	$P_{IN} = +9.5$ dBm		-26.6		dBm
Non-Harmonic Spurious				-36	dBm
Input VSWR	$(P_{OUT,MAX} - 5$ dB) < P_{OUT} < $P_{OUT,MAX}$		1.72:1		
	$P_{OUT} < (P_{OUT,MAX} - 5$ dB)		2.48:1		
Output Load VSWR, Stability	Spurious < -36 dBm, RBW = 100 kHz V_{APC1} and V_{APC2} from 0.3 V to 2.6 V	8:1			
Output Load VSWR, Ruggedness, 3.6V	No damage, $V_{CC}=3.6$ V, $P_{in}=4.5$ dBm, - 40<= T_a <=85	10:1			
Power Control "ON" Voltage	V_{APC1} and V_{APC2} ; Maximum P_{OUT}		2.8		V
Power Control "OFF" Voltage	V_{APC1} and V_{APC2} ; Minimum P_{OUT}	0.2	0.5		V
Gain Control Range	V_{APC1} and V_{APC2} from 0.2 V to 2.6 V	76			dB
Gain Control Slope	P_{OUT} from -10 dBm to +35 dBm		35.7		dB/V
APC Input Capacitance	DC to 2 MHz			0.2	pF
APC Input Current	V_{APC1} and $V_{APC2} = 2.8$ V		4.6		mA
	V_{APC1} and $V_{APC2} = 0$ V			25	μ A
Turn ON/OFF Time	V_{APC1} and V_{APC2} from 0 V to 2.8 V		175		ns
Device Current (I_{CC1} , I_{CC2} and I_{CC3})	At Maximum Output Power		1.7		A
	Quiescent, $P_{IN} < -30$ dBm		208		mA
	Standby Mode, $P_{IN} < -30$ dBm		58		μ A
	Standby Mode, $P_{IN} < -30$ dBm, Temp = +85 °C			10	μ A
Thermal Resistance, θ_{jc}	CW Mode, Junction to case		12.5		°C/W

Notes:

- Test conditions unless otherwise noted: $V_{CC} = V_{CC1} = V_{CC2} = +3.6$ V; V_{APC1} and $V_{APC2} = 2.8$ V; $P_{in}=+4.5$ dBm; Duty Cycle = 37.5%; Temp = +25 °C; 50 Ω system.

Performance Plots – 900MHz GSM

Test conditions unless otherwise noted: $V_{CC} = V_{CC1} = V_{CC2} = +3.6V$, $V_{APC1} = V_{APC2} = +2.8V$, $I_{CQ} = 215\text{ mA}$, $\text{Temp} = +25^\circ\text{C}$, 50Ω system.

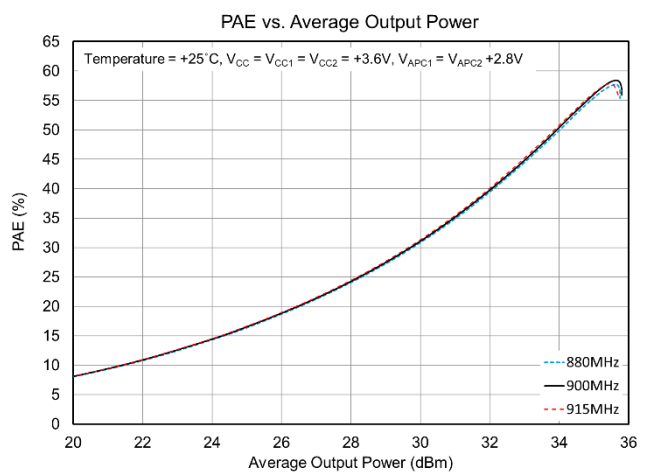
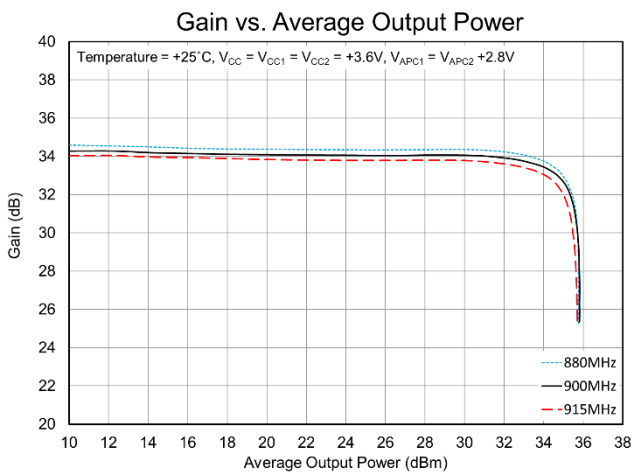
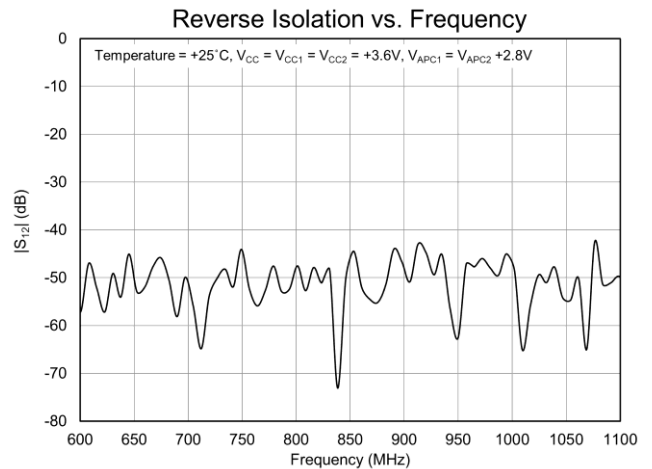
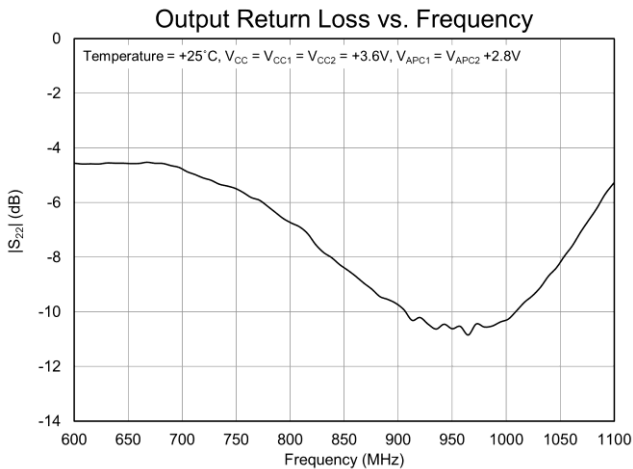
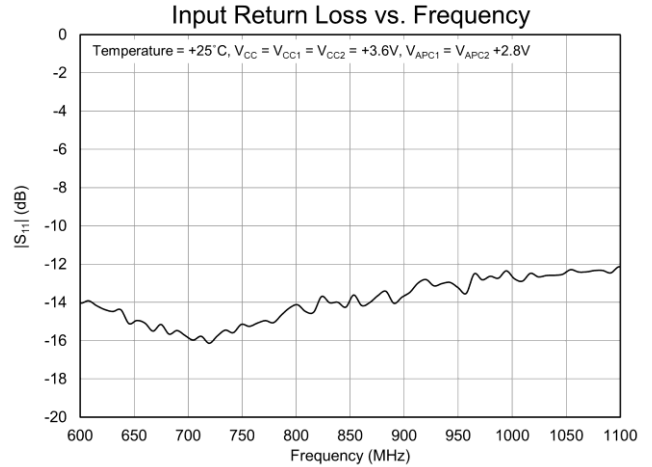
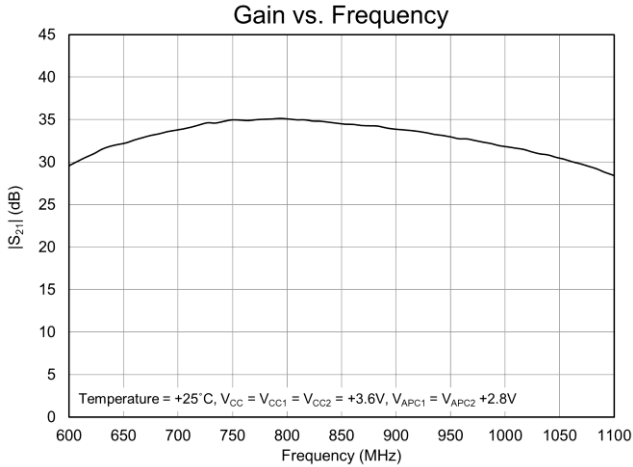

Performance Plots – 900MHz GSM (Continued)

Test conditions unless otherwise noted: $V_{CC} = V_{CC1} = V_{CC2} = +3.6V$, $V_{APC1} = V_{APC2} = +2.8V$, $I_{CQ} = 215\text{ mA}$, $\text{Temp} = +25^\circ\text{C}$, 50Ω system.

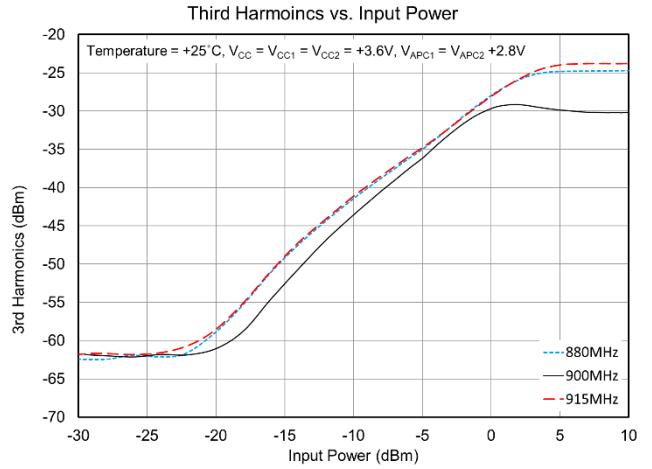
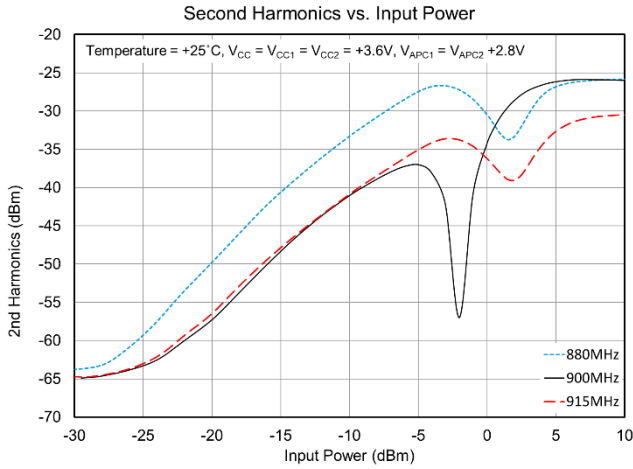

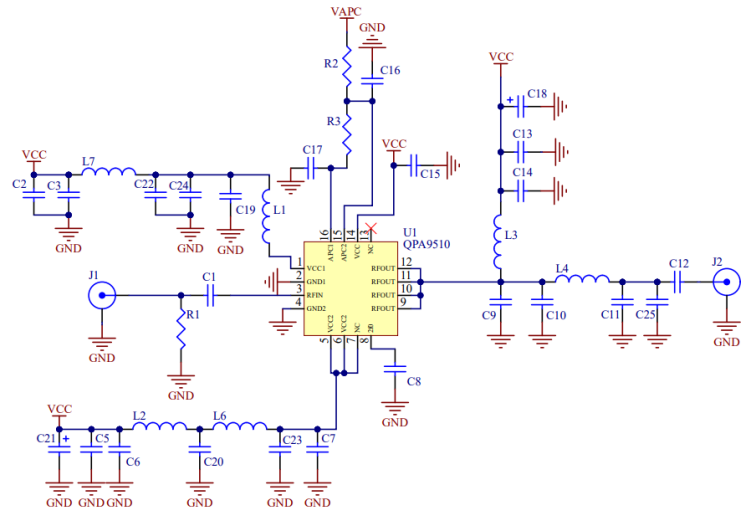
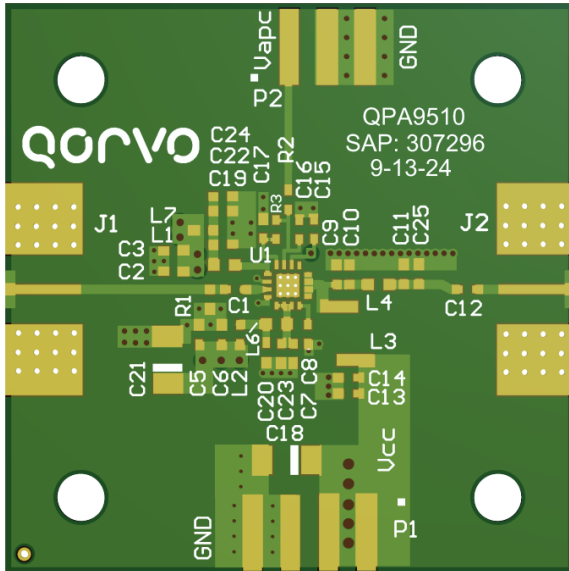
Evaluation Board – 900MHz GSM

Notes:

1. Components shown on PCB layout but not on the schematic are not used.

Bill of Materials

Reference Des.	Value	Description	Manuf.	Part Number
n/a	n/a	Printed Circuit Board	Qorvo	
U1	n/a	QPA9510 Amplifier, QFN pkg.	Qorvo	QPA9510
C14, C15	47pF	CAP, 47pF, 0402, 1%, 50V, C0G	Murata	GRM1555C1H470JA01D
C1, C12	56pF	CAP, 56pF, 0402, 5%, 50V, C0G	Murata	GRM1555C1H560JA01D
C11	5.6pF	CAP, 5.6pF, 0402, ± 0.25 pF, 50V, HI-Q	Johanson	500R07S5R6CV4TD
C9	15pF	CAP, 15pF, 0402, 5%, 50V, HI-Q	Johanson	500R07S150JV4TD
C10	11pF	CAP, 11pF, 0402, 5%, 50V, HI-Q	Johanson	500R07S110JV4TD
C18, C21	3.3uF	CAP, 3.3uF, TANT-A, 20%, 25V	Kyocera	TAJA335M025RNJ
C3, C6, C13	1000pF	CAP, 1000pF, 0402, 5%, 50V, C0G	Murata	GRM155R71H102KA01D
C2, C5, C16, C17	10000pF	CAP, 10000pF, 0402, 10%, 50V, X7R	Murata	GRM155R71E103KA01D
C8	1.5pF	CAP, 1.5pF, 0402, ± 0.1 pF, 100V, HI-Q	Johanson	500R07S1R5BV4TD
C7, C19, C23	27pF	CAP, 27pF, 0402, 5%, NP0, 50V, NISN	Murata	GRM1555C1H270JA01D
C20	15pF	CAP, 15pF, 0402, 5%, NP0, 50V, NISN	Murata	GRM1555C1H150JA01D
R1	180 Ω	RES, 180 OHM, 0402, 5%, 1/16W	Panasonic	ERJ-2GEJ181X
R2, R3	0 Ω	RES, 0 OHM, 0402, 1/10W	Kamaya	RMC1/16SJPTH
L6	1.6nH	IND, 1.6nH, 0603, 5%, W/W	Coilcraft	0603CS-1N6XJLW
L4	3.6nH	IND, 3.6nH, 0603, 5%, W/W	Coilcraft	0603CS-3N6XJLW
L1	11nH	IND, 11nH, 0603, 5%, W/W	Coilcraft	0603CS-11NXJLW
L3	8.8nH	IND, 8.8nH, 1606, 5%, W/W	Coilcraft	1606-8JLC
L2, L7	10 Ω	RES, 10 OHM, 0402, Ferrite Bead, 500mA	Murata	BLM15AG100SN1D
C22, C24, C25	DNP	n/a	n/a	

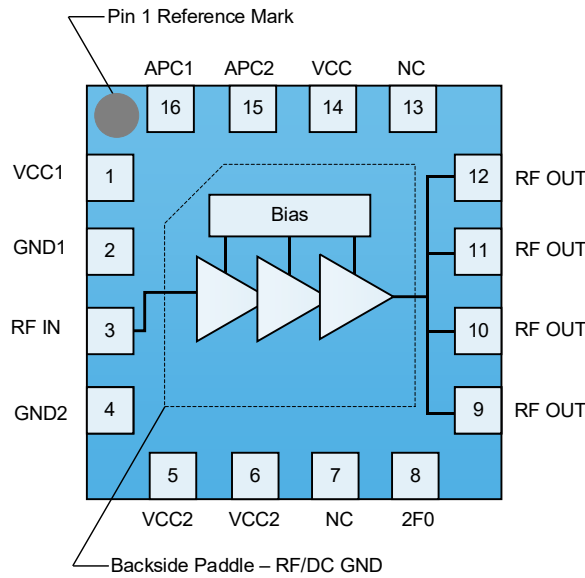
Pad Configuration and Description



Top View

Pad No.	Label	Description
1	VCC1	Power supply for the pre-amplifier stage and interstage matching. This pin forms the shunt inductance needed for proper tuning of the interstage match. Refer to the application circuit for proper configuration. Note that position and value of the components are important.
2	GND1	Ground connection for the pre-amplifier stage. Keep traces physically short and connect immediately to the ground plane for best performance. For stability concert, this pin requires dedicated ground via holes to the ground plane to minimize any common inductance.
3	RF IN	RF Input. This is a 50Ω input, but the actual impedance could be affected by the interstage matching network connected on pin 1. An external DC blocking capacitor is required.
4	GND2	Ground connection for the driver stage. To minimize the noise power at the output, it is recommended to connect this pin with a trace of about 40mil long to the ground plane. This will slightly reduce the small signal gain. For stability concert, this pin requires dedicated ground via holes to the ground plane to minimize any common inductance.
5, 6	VCC2	Power supply for the driver stage and interstage matching. This pin requires a shunt inductance for proper interstage matching. Please refer to the application schematic for proper configuration.
7, 13	NC	Not connected.
8	2F0	Connection for the second harmonic trap. This pin is internally connected to the RF OUT pins. With the bonding wire together with an external capacitor form a series resonator. It should provide a second harmonic short termination to improve amplifier efficiency and reduce spurious outputs.
9, 10, 11,12	RF OUT	RF Output and power supply for the output stage. Bias voltage for the final stage is provided through this wide output pins. An external matching network is required to provide the optimum performance.
14	VCC	Power supply for the bias circuits.
15	APC2	Power control for the output stage. See pin 16 for more details.
16	APC1	Power control for the driver and pre-amplifier stages. When this pin is “low”, all circuits shut off. A “low” is typically 0.5V or less at room temperature. A shunt bypass capacitor is required. For a typical power control operation, the V_{APC1} is about 1.0V for -10dBm to 2.6V for +35dBm RF output power. The maximum power that can be achieved depends on the actual output matching; see the application circuit for more details.
Backside Paddle	GND	Ground connection. The back side of the package should be connected to the ground plan though as short of a connection as possible. PCB vias under the device are recommended.

Tape and Reel Information – Carrier and Cover Tape Dimensions

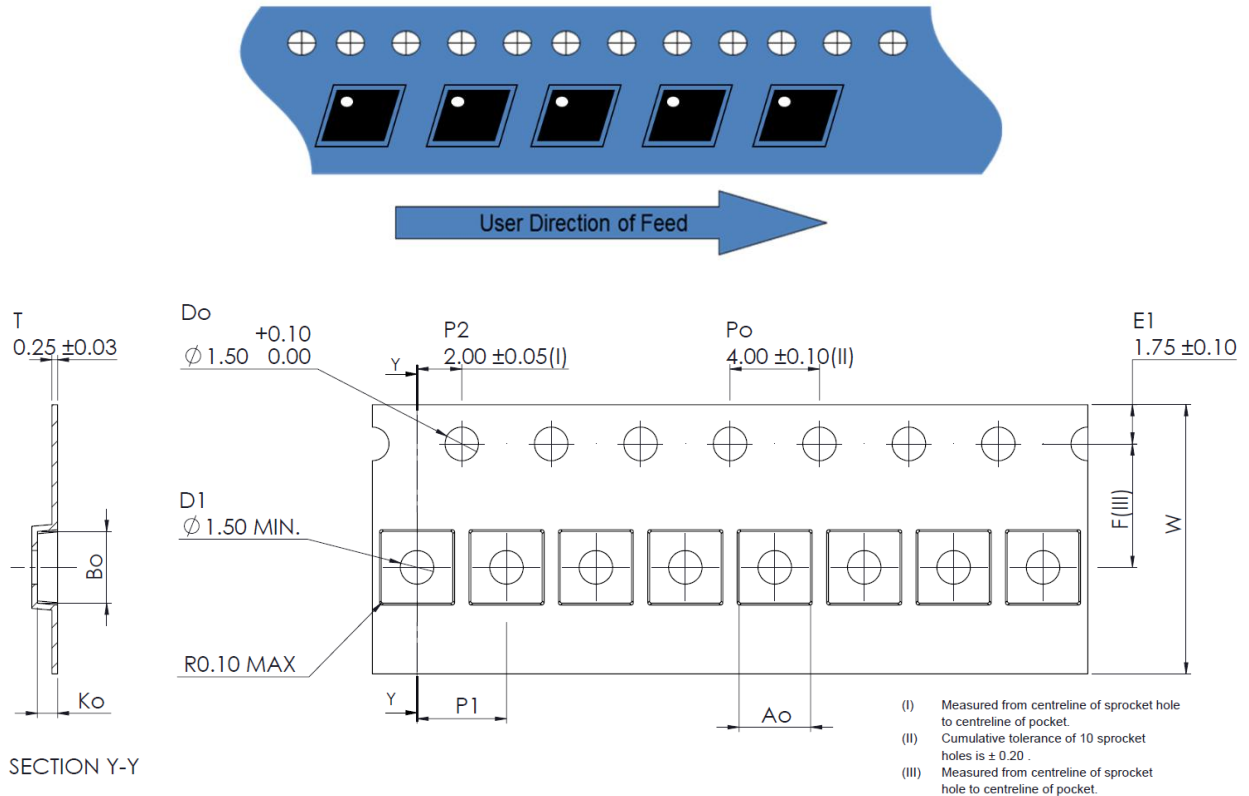

Feature	Measure	Symbol	Size (in)	Size (mm)
Cavity	Length	A0	0.125	3.20
	Width	B0	0.125	3.20
	Depth	K0	0.040	1.00
	Pitch	P1	0.157	4.00
Centerline Distance	Cavity to Perforation - Length Direction	P2	0.079	2.00
	Cavity to Perforation - Width Direction	F	0.217	5.50
Cover Tape	Width	C	0.362	9.20
Carrier Tape	Width	W	0.472	12.0

Tape and Reel Information – Reel Dimensions

Standard T/R size = 2,500 pieces on a 13" reel.

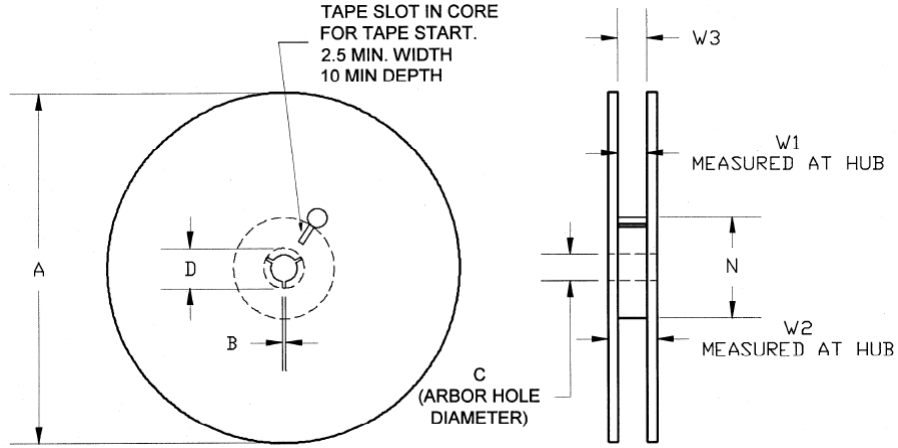

Feature	Measure	Symbol	Size (in)	Size (mm)
Flange	Diameter	A	12.992	330.00
	Thickness	W2	0.717	18.20
	Space Between Flange	W1	0.504	12.80
Hub	Outer Diameter	N	4.016	102.00
	Arbor Hole Diameter	C	0.512	13.00
	Key Slit Width	B	0.079	2.00
	Key Slit Diameter	D	0.787	20.00

Tape and Reel Information – Tape Length and Label Placement

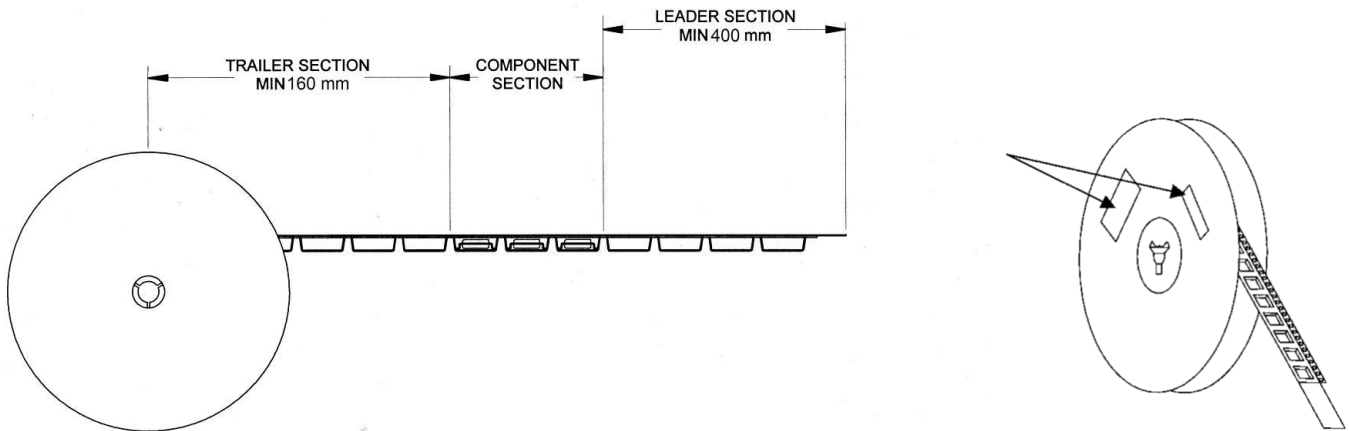

- Notes:
1. Empty part cavities at the trailing and leading ends are sealed with cover tape. See EIA 481-1-A.
 2. Labels are placed on the flange opposite the sprockets in the carrier tape.

Handling Precautions

Parameter	Rating	Standard
ESD – Human Body Model (HBM)	1B	ESDA / JEDEC JS-001-2012
ESD – Charged Device Model (CDM)	C3	JEDEC JESD22-C101F
MSL – Moisture Sensitivity Level	MSL3	IPC/JEDEC J-STD-020



Caution!
ESD-Sensitive Device

RoHS Compliance

This part is compliant with 2011/65/EU RoHS directive (Restrictions on the Use of Certain Hazardous Substances in Electrical and Electronic Equipment) as amended by Directive 2015/863/EU.

This product also has the following attributes:

- Lead Free
- Halogen Free (Chlorine, Bromine)
- Antimony Free
- TBBP-A (C₁₅H₁₂Br₄O₂) Free
- PFOS Free
- SVHC Free

Contact Information

For the latest specifications, additional product information, worldwide sales and distribution locations:

Web: www.qorvo.com

Tel: 1-844-890-8163

Email: customer.support@qorvo.com

Important Notice

The information contained in this Data Sheet and any associated documents (“Data Sheet Information”) is believed to be reliable; however, Qorvo makes no warranties regarding the Data Sheet Information and assumes no responsibility or liability whatsoever for the use of said information. All Data Sheet Information is subject to change without notice. Customers should obtain and verify the latest relevant Data Sheet Information before placing orders for Qorvo® products. Data Sheet Information or the use thereof does not grant, explicitly, implicitly or otherwise any rights or licenses to any third party with respect to patents or any other intellectual property whether with regard to such Data Sheet Information itself or anything described by such information.

DATA SHEET INFORMATION DOES NOT CONSTITUTE A WARRANTY WITH RESPECT TO THE PRODUCTS DESCRIBED HEREIN, AND QORVO HEREBY DISCLAIMS ANY AND ALL WARRANTIES WITH RESPECT TO SUCH PRODUCTS WHETHER EXPRESS OR IMPLIED BY LAW, COURSE OF DEALING, COURSE OF PERFORMANCE, USAGE OF TRADE OR OTHERWISE, INCLUDING THE IMPLIED WARRANTIES OF MERCHANTABILITY AND FITNESS FOR A PARTICULAR PURPOSE. Without limiting the generality of the foregoing, Qorvo® products are not warranted or authorized for use as critical components in medical, life-saving, or life-sustaining applications, or other applications where a failure would reasonably be expected to cause severe personal injury or death. Applications described in the Data Sheet Information are for illustrative purposes only. Customers are responsible for validating that a particular product described in the Data Sheet Information is suitable for use in a particular application.

© 2025 Qorvo US, Inc. All rights reserved. This document is subject to copyright laws in various jurisdictions worldwide and may not be reproduced or distributed, in whole or in part, without the express written consent of Qorvo US, Inc. | QORVO® is a registered trademark of Qorvo US, Inc.

Looking for pricing, stock, or lifecycle information?

Click below to explore more details on WIN SOURCE:

 [View QPA9510TR7 on WIN SOURCE](#)

 [Qorvo US Inc. Information](#)

Optimize Your Supply Chain with WIN SOURCE Solutions

-  Global Sourcing Solution
-  Obsolete Management
-  Cost Control Management
-  Shortage Management
-  Alternative Solution
-  Excess Inventory Management