

FEATURES

- 3 dB bandwidth: 10.0 GHz
- Preset 10 dB gain, can be reduced by adding external resistors
- Differential or single-ended input to differential output
- Internally dc-coupled inputs and outputs
- Input voltage noise (NSD, RTI): 2.25 nV/ $\sqrt{\text{Hz}}$ at 100 MHz
- Low noise input stage: 11.3 dB noise figure at 1 GHz
- Low distortion with +5.0 V and –1.8 V supplies and 1.4 V p-p output differential with a 50 Ω || 1 pF load differential
- 2 GHz: –59.4 dBc (HD2), –54.3 dBc (HD3), –68.2 dBc (IMD3)
- 6 GHz: –66 dBc (HD2), –88.1 dBc (HD3), –48.3 dBc (IMD3)
- 276 mA positive supply current at 5.0 V typical
- 224 mA negative supply current at –1.8 V typical
- Power disable

APPLICATIONS

Instrumentation and defense applications

GENERAL DESCRIPTION

The ADL5580 is a high performance, single-ended or differential amplifier with 10 dB of voltage gain, optimized for applications spanning from dc to 10.0 GHz. The amplifier offers a low referred to input (RTI) noise spectral density (NSD) of 2.24 nV/ $\sqrt{\text{Hz}}$ (at 1000 MHz) and is optimized for distortion performance over a wide frequency range, making the device an ideal driver for high speed 12-bit to 16-bit analog-to-digital converters (ADCs). The ADL5580 is suited for use in high performance, zero intermediate frequency (IF), and complex IF receiver designs. In addition, this device has low distortion for single-ended input driver applications.

By using two external series resistors, the gain selection from 10 dB for a differential input can be modified to a lower gain. The device maintains low distortion through its output common-mode voltage (V_{CM}) of 0.5 V, providing a flexible capability for driving ADCs with full-scale levels up to 1.4 V p-p.

FUNCTIONAL BLOCK DIAGRAM

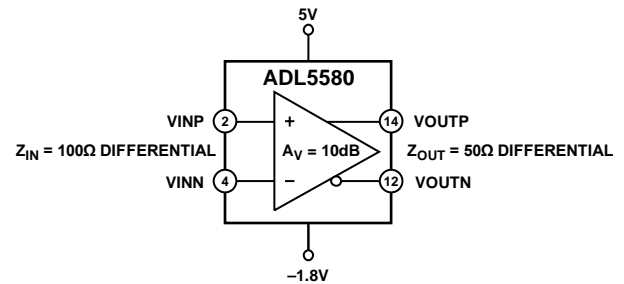

Figure 1.

17004-001

Operating from a +5 V and –1.8 V supply, the positive and negative supply current of the ADL5580 is typically +276 mA and –224 mA, respectively. The device has a power disable feature, and when disabled, the amplifier consumes 2 mA.

The ADL5580 is optimized for wideband, low distortion, and low noise operation at the dc to 10.0 GHz frequency range. These attributes, together with its adjustable gain capability, make this device an optimal choice for driving a wide variety of ADCs, mixers, pin diode attenuators, surface acoustic wave (SAW) filters, and a multiplicity of discrete RF devices.

Fabricated on an Analog Devices, Inc., high speed silicon germanium (SiGe) process, the ADL5580 is supplied in a compact 4 mm × 4 mm, 20-terminal land grid array (LGA) package and operates over the –40°C to +85°C temperature range.

TABLE OF CONTENTS

Features	1	RF Input and Output with Common-Mode Network.....	15
Applications	1	RF Signal Chain	15
Functional Block Diagram	1	Programmability Guide.....	15
General Description	1	SPI	15
Revision History	2	Applications Information	16
Specifications	3	Basic Connections.....	16
Digital Logic Timing.....	6	Input and Output Interfacing.....	17
Absolute Maximum Ratings	8	Layout	17
Thermal Resistance	8	Register Summary	18
ESD Caution.....	8	Register Details	19
Pin Configuration and Function Descriptions	9	Outline Dimensions.....	22
Typical Performance Characteristics.....	10	Ordering Guide	22
Theory of Operation	15		

REVISION HISTORY

12/2020—Revision 0: Initial Version

SPECIFICATIONS

Positive supply voltage (V_S) = +5.0 V, negative V_S = -1.8 V, input V_{CM} = 1.7 V, output V_{CM} = 0.5 V, source impedance (R_S) = 100 Ω differential, load impedance (R_L) = 50 Ω differential, output voltage (V_{OUT}) = 1.4 V p-p composite, peak capacitance (C_{PEAK}) = 3, T_A = 25°C, and signal spacing = 2 MHz for two-tone measurements, unless otherwise noted.

Table 1.

Parameter	Test Conditions/Comments	Min	Typ	Max	Unit
DYNAMIC PERFORMANCE					
-3 dB Bandwidth ¹	$V_{OUT} \leq 1.4$ V p-p		10.0		GHz
Bandwidth, 1.0 dB Flatness	$V_{OUT} \leq 1.4$ V p-p		6		GHz
Voltage Gain (A_V)					
Differential Input	$R_L = 50 \Omega 1$ pF differential		10		dB
Single-Ended Input	$R_L = 50 \Omega 1$ pF differential		10		dB
Gain Supply Sensitivity	Positive $V_S \pm 5\%$ and negative $V_S \pm 5\%$		128		mdB/V
Gain Temperature Sensitivity	$T_A = -40^\circ\text{C}$ to $+85^\circ\text{C}$		10.7		mdB/ $^\circ\text{C}$
Slew Rate	Rising, $V_{OUT} = 1.4$ V p-p step		24		V/ns
	Falling, $V_{OUT} = 1.4$ V p-p step		24		V/ns
Settling Time	1.4 V step to 1%		2.4		ns
Overdrive Settling Time	Differential output voltage 2.8 V p-p		640		ps
EN Response Time	From shutdown mode		20		ns
	To shutdown mode		6		ns
Reverse Isolation (SDD12)	Frequency = 1000 MHz		-70		dB
Input to Output Isolation when Disabled	Frequency = 1000 MHz, EN pin set to low		-87		dBc
INPUT AND OUTPUT CHARACTERISTICS					
Input V_{CM}	VCMI		1.7		V
Input Resistance					
Differential			100		Ω
Single-Ended			100		Ω
Common-Mode Rejection Ratio (CMRR)	Frequency = 1000 MHz		32.9		dB
Output V_{CM}	VCMO		0.5		V
Output Resistance (Differential)			50		Ω
VCMI and VCMO Input Impedance			10		k Ω
Input Common-Mode					
Offset			97.7		mV
Drift	$T_A = 25^\circ\text{C}$ to 85°C		0.188		mV/ $^\circ\text{C}$
Input Differential Offset					
Voltage			0.4		mV
Drift	$T_A = -40^\circ\text{C}$ to $+25^\circ\text{C}$		3.076		$\mu\text{V}/^\circ\text{C}$
Output Common-Mode					
Offset			6.6		mV
Drift	$T_A = -40^\circ\text{C}$ to $+25^\circ\text{C}$		0.119		mV/ $^\circ\text{C}$
Output Differential Offset					
Voltage			0.4		mV
Drift	$T_A = 25^\circ\text{C}$ to 85°C		6.666		$\mu\text{V}/^\circ\text{C}$
Maximum Output Voltage Swing	Frequency = 1000 MHz, 1 dB compression point		5		V p-p

Parameter	Test Conditions/Comments	Min	Typ	Max	Unit
NOISE AND HARMONIC PERFORMANCE					
Input Signal Frequency, 100 MHz					
Second Harmonic Distortion (HD2)			-77.2		dBc
Third Harmonic Distortion (HD3)			-74.2		dBc
Output Third-Order Intercept (OIP3)			43.6		dBm
Third-Order Intermodulation Distortion (IMD3)			-84.7		dBc
Output Second-Order Intercept (OIP2)			77.7		dBm
Second-Order Intermodulation Distortion (IMD2)			-76.4		dBc
Output 1 dB Compression Point (OP1dB)			17.5		dBm
Noise Figure			11.3		dB
NSD, RTI ²			2.25		nV/√Hz
Input Signal Frequency, 500 MHz					
HD2			-66.4		dBc
HD3			-66.1		dBc
OIP3			40.3		dBm
IMD3			-78.2		dBc
OIP2			66.8		dBm
IMD2			-65.6		dBc
OP1dB			17.5		dBm
Noise Figure			11.2		dB
NSD, RTI ²			2.23		nV/√Hz
Input Signal Frequency, 1000 MHz					
HD2			-66.3		dBc
HD3			-61.1		dBc
OIP3			38.1		dBm
IMD3			-73.5		dBc
OIP2			65.9		dBm
IMD2			-64.7		dBc
OP1dB			17.5		dBm
Noise Figure			11.3		dB
NSD, RTI ²			2.24		nV/√Hz
Input Signal Frequency, 2000 MHz					
HD2			-59.4		dBc
HD3			-54.3		dBc
OIP3			35.3		dBm
IMD3			-68.2		dBc
OIP2			60.2		dBm
IMD2			-59.1		dBc
OP1dB			17.5		dBm
Noise Figure			11.4		dB
NSD, RTI ²			2.26		nV/√Hz

Parameter	Test Conditions/Comments	Min	Typ	Max	Unit
Input Signal Frequency, 3000 MHz					
HD2			-60.6		dBc
HD3			-47.1		dBc
OIP3			32.8		dBm
IMD3			-63.2		dBc
OIP2			69.8		dBm
IMD2			-68.6		dBc
OP1dB			17.5		dBm
Noise Figure			10.9		dB
NSD, RTI ²			2.13		nV/ $\sqrt{\text{Hz}}$
Input Signal Frequency, 4000 MHz					
HD2			-58		dBc
HD3			-54.8		dBc
OIP3			30.7		dBm
IMD3			-53.9		dBc
OIP2			58.6		dBm
IMD2			-57.3		dBc
OP1dB			18.0		dBm
Noise Figure			10.3		dB
NSD, RTI ²			1.96		nV/ $\sqrt{\text{Hz}}$
Input Signal Frequency, 5000 MHz					
HD2			-60		dBc
HD3			-72.1		dBc
OIP3			28.1		dBm
IMD3			-53.9		dBc
OIP2			60.9		dBm
IMD2			-59.7		dBc
OP1dB			17.5		dBm
Noise Figure			10.0		dB
NSD, RTI ²			1.90		nV/ $\sqrt{\text{Hz}}$
Input Signal Frequency, 6000 MHz					
HD2			-66		dBc
HD3			-88.1		dBc
OIP3			25.4		dBm
IMD3			-48.3		dBc
OIP2			67.3		dBm
IMD2			-66.1		dBc
OP1dB			17.0		dBm
NF			9.5		dB
NSD, RTI ²			1.78		nV/ $\sqrt{\text{Hz}}$
DIGITAL LOGIC					
Input Voltage	SCLK, SDIO, $\overline{\text{CS}}$, and EN		1.07		V
High (V _{IH})					V
Low (V _{IL})				0.68	V
Input Current					μA
High (I _{IH})				-100	μA
Low (I _{IL})				100	μA

Parameter	Test Conditions/Comments	Min	Typ	Max	Unit
Output Voltage	SDIO				
At 1.8 V	Register 0x200, Bit 0 = 0x0				
High (V _{OH})	Output high current (I _{OH}) = -100 μA or -1 mA static load	1.5			V
Low (V _{OL})	Output low current (I _{OL}) = 100 μA or 1 mA static load			0.2	V
At 3.3 V	Register 0x200, Bit 0 = 0x1				
V _{OH}	I _{OH} = -100 μA or -1 mA static load	2.7			V
V _{OL}	I _{OL} = 100 μA or 1 mA static load			0.2	V
SUPPLY AND POWER SPECIFICATIONS					
Power			1.76		W
Shutdown Power	At room temperature		11		mW
Shutdown Current	At room temperature		2		mA
Positive Supply					
Voltage (V _{PAVCC})	5%	4.75	5.0	5.25	V
Current (I _{PAVCC})			276		mA
Negative Supply					
Voltage (V _{MAVEE})	5%	-1.7	-1.8	-1.89	V
Current (I _{MAVEE})			-224		mA

¹ S parameters are taken with the device under test (DUT) itself. The printed circuit board (PCB) is not used in the measurement.

² NSD RTI is calculated from noise figure as follows, assuming that R_s = R_i:

$$NSD(RTI) = \frac{1}{2} \times \sqrt{4kT \times (10^{NF/10} - 1) \times R_{IN}}$$

where:

k is Boltzmann's constant, which equals 1.381 × 10⁻²³J/K.

T is the standard absolute temperature for evaluating noise figure, which equals 290 K.

R_{IN} is the differential input impedance of the amplifier, which equals 100 Ω.

DIGITAL LOGIC TIMING

Table 2.

Parameter	Description	Min	Typ	Max	Unit
f _{SCLK}	Maximum serial clock rate, 1/t _{SCLK} (t _{SCLK} is the SCLK time)		25		MHz
t _{PWH}	Minimum period that SCLK is in logic high state		10		ns
t _{PWL}	Minimum period that SCLK is in logic low state		10		ns
t _{DS}	Setup time between data and rising edge of SCLK		5		ns
t _{DH}	Hold time between data and rising edge of SCLK		5		ns
t _{DCS}	Setup time between falling edge of \overline{CS} and rising edge of SCLK		10		ns
t _H	Hold time between rising edge of \overline{CS} and the last falling edge of SCLK		10		ns
t _{DV}	Maximum time delay between falling edge of SCLK and output data valid for a read operation		5	14	ns
t _Z	Maximum time delay between \overline{CS} deactivation and SDIO bus return to high impedance			12	ns

Timing Diagrams

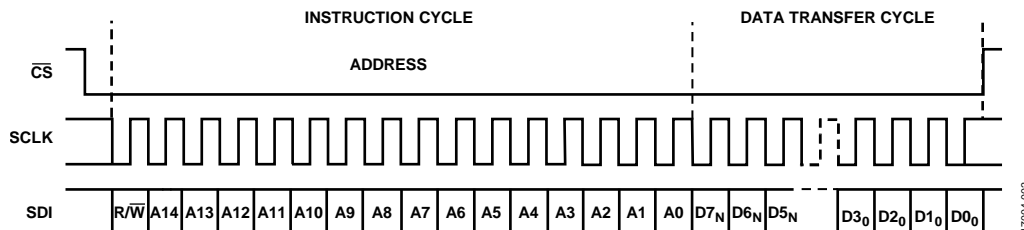

Figure 2. Serial Port Interface Register Timing, MSB First

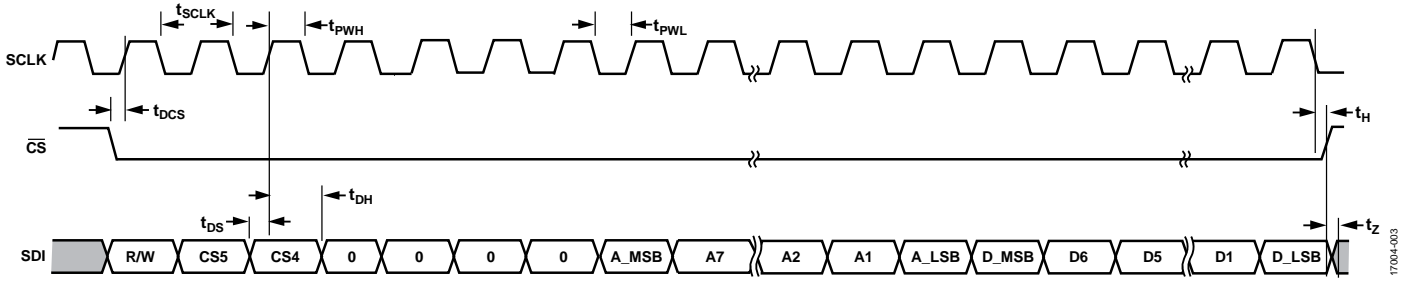

Figure 3. Timing Diagram for the Serial Port Interface Register Write

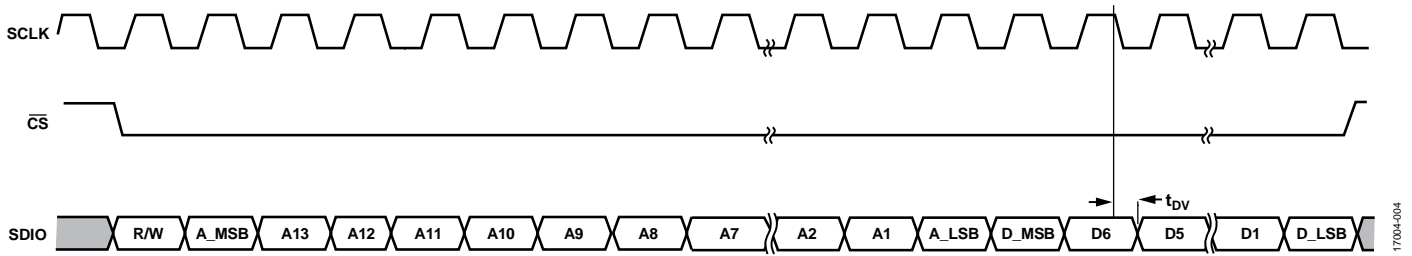

Figure 4. Timing Diagram for Serial Port Interface Register Read

ABSOLUTE MAXIMUM RATINGS

Table 3.

Parameter	Rating
Supply Voltage	
At PAVCC	5.5 V
At MAVEE	-1.98 V
RF Input Power (VINP and VINN) at 100 Ω	± 350 mV
\overline{CS} , SCLK, SDIO, and EN	-0.3 V to +3.6 V
Temperature	
Operating Range	-40°C to +85°C
Maximum Junction	125°C
Storage	150°C

Stresses at or above those listed under Absolute Maximum Ratings may cause permanent damage to the product. This is a stress rating only; functional operation of the product at these or any other conditions above those indicated in the operational section of this specification is not implied. Operation beyond the maximum operating conditions for extended periods may affect product reliability.

THERMAL RESISTANCE

Thermal performance is directly linked to PCB design and operating environment. Careful attention to PCB thermal design is required.

Table 4. Thermal Resistance

Package Type ¹	θ_{JA}	θ_{JTOP}	$\theta_{JBOTTOM}$	θ_{JB}	ψ_{JT}	ψ_{JB}	Unit
CC-20-7	53.5	24.3	20.9	24.2	6.0	25.5	°C/W

¹ Thermal resistance values specified are simulated based on JEDEC specifications in compliance with JESD-51.

ESD CAUTION



ESD (electrostatic discharge) sensitive device. Charged devices and circuit boards can discharge without detection. Although this product features patented or proprietary protection circuitry, damage may occur on devices subjected to high energy ESD. Therefore, proper ESD precautions should be taken to avoid performance degradation or loss of functionality.

PIN CONFIGURATION AND FUNCTION DESCRIPTIONS

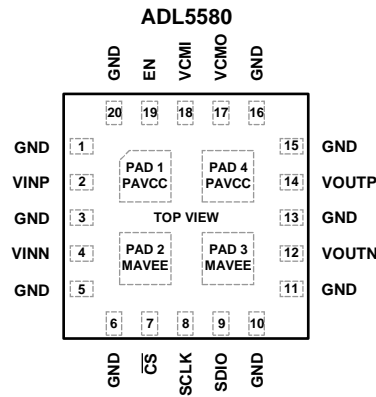

NOTES
 1. PAD 1 AND PAD 4 ARE THE POSITIVE VOLTAGE SUPPLY, 5.0V.
 2. PAD 2 AND PAD 3 ARE THE NEGATIVE VOLTAGE SUPPLY, -1.8V.

17004-005

Figure 5. Pin Configuration

Table 5. Pin Function Descriptions

Pin No	Mnemonic	Description
1, 3, 5, 6, 10, 11, 13, 15, 16, 20	GND	Ground. Connect the GND pins to ground.
2	VINP	Positive RF Input (RFIN) Signal. VINP is the positive side of the amplifier balanced differential inputs.
4	VINN	Negative RFIN Signal. VINN is the negative side of the amplifier balanced differential inputs.
7	\overline{CS}	Serial Peripheral Interface (SPI) Chip Select. \overline{CS} is a digital input.
8	SCLK	SPI Serial Clock. SCLK is a digital input.
9	SDIO	SPI Serial Data Input and Output. SDIO is a digital input and output.
12	VOUTN	Negative RF Output (RFOUT) Signal. VOUTN is the negative side of the amplifier balanced differential outputs.
14	VOUTP	Positive RFOUT Signal. VOUTP is the positive side of the amplifier balanced differential outputs.
17	VCMO	V_{CM} for the RF Output Signal.
18	VCM	V_{CM} for the RF Input Signal.
19	EN	Digital Input Power Enable.
PAD1, PAD4	PAVCC	Positive Voltage Supply, 5.0 V.
PAD2, PAD3	MAVEE	Negative Voltage Supply, -1.8 V.

TYPICAL PERFORMANCE CHARACTERISTICS

$V_S = 5.0\text{ V}$, negative $V_S = -1.8\text{ V}$, input $V_{CM} = 1.7\text{ V}$, output $V_{CM} = 0.5\text{ V}$, $R_S = 100\ \Omega$ differential, $R_L = 50\ \Omega$ differential $V_{OUT} = 1.4\text{ V p-p}$ composite, $C_{PEAK} = 3$, $T_A = 25^\circ\text{C}$, and signal spacing = 2 MHz for two-tone measurements, unless otherwise noted.

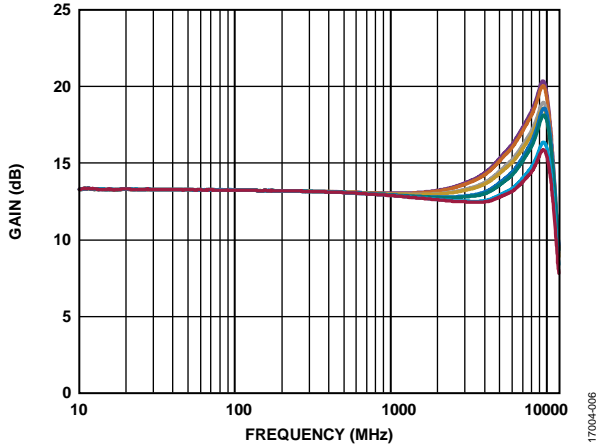

Figure 6. Gain vs. Frequency for $C_{PEAK} = 0$ Through $C_{PEAK} = 7$, Supply = Nominal, Temperature = 25°C

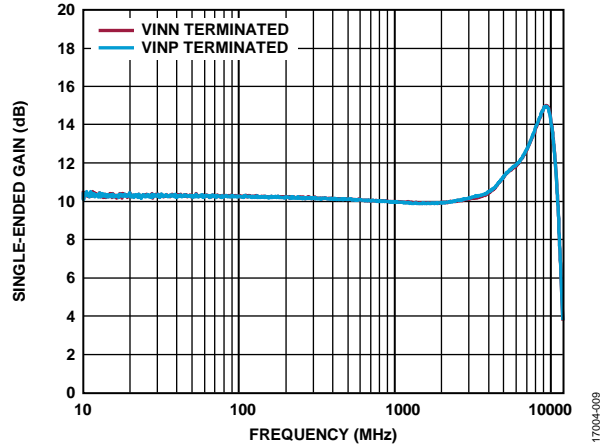

Figure 9. Single-Ended Gain vs. Frequency, Temperature = 25°C , $C_{PEAK} = 3$, Supply = Nominal

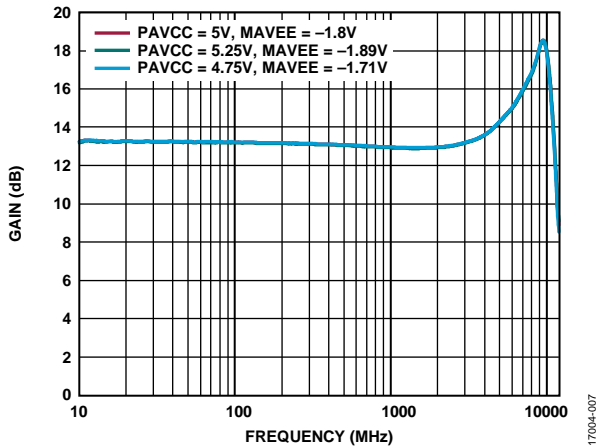

Figure 7. Gain vs. Frequency over Supply, $C_{PEAK} = 3$, Temperature = 25°C

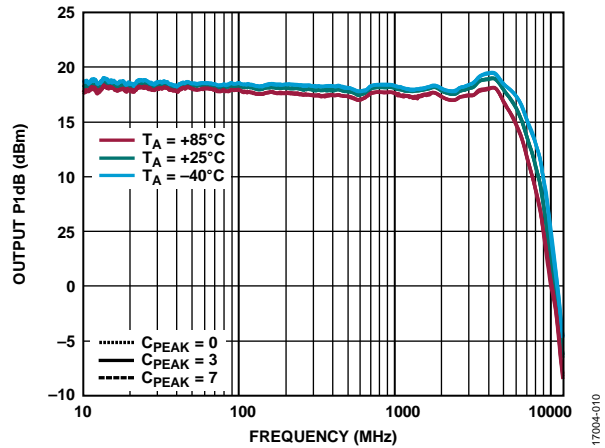

Figure 10. Output P1dB vs. Frequency over Temperature, Supply = Nominal, $C_{PEAK} = 0$, $C_{PEAK} = 3$, and $C_{PEAK} = 7$

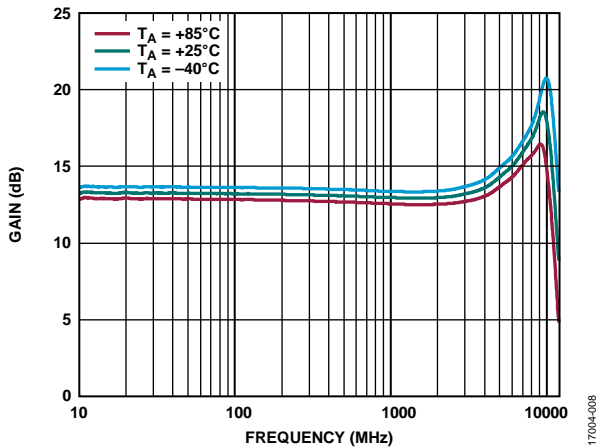

Figure 8. Gain vs. Frequency over Temperature, $C_{PEAK} = 3$, Supply = Nominal

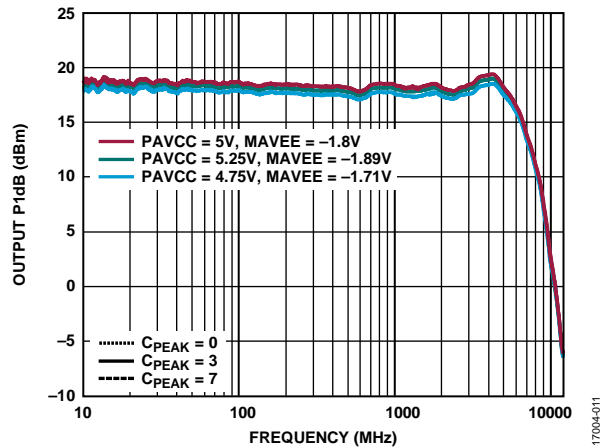

Figure 11. Output P1dB vs. Frequency over Supply, Temperature = 25°C , $C_{PEAK} = 0$, $C_{PEAK} = 3$, and $C_{PEAK} = 7$

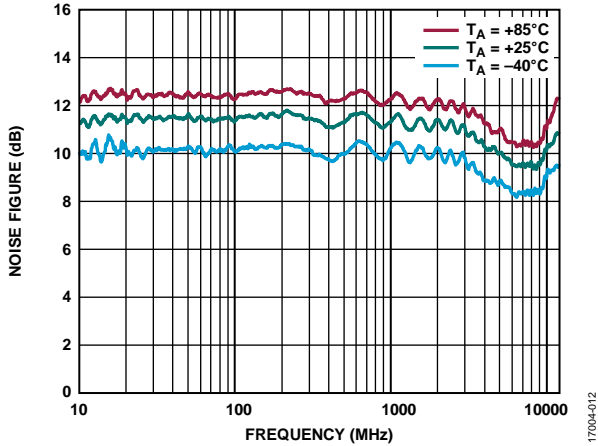

Figure 12. Noise Figure vs. Frequency over Temperature, $C_{PEAK} = 3$, Supply = Nominal

17004-012

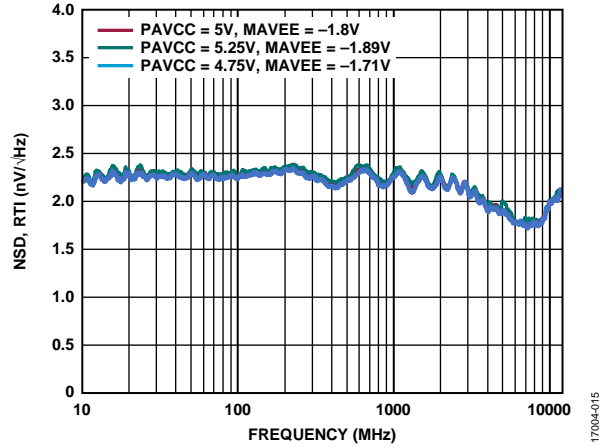

Figure 15. NSD, RTI vs. Frequency over Supply, Temperature = 25°C, $C_{PEAK} = 3$

17004-015

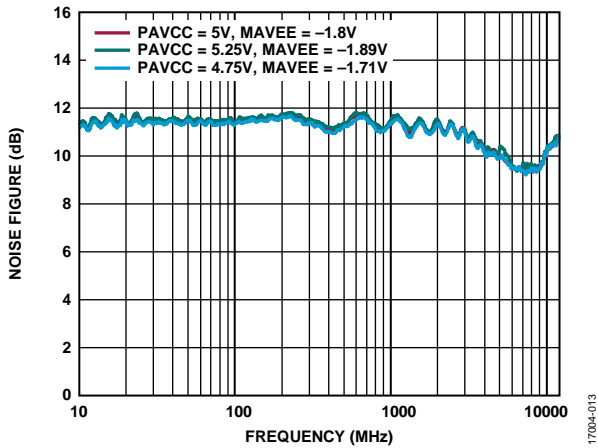

Figure 13. Noise Figure vs. Frequency over Supply, $C_{PEAK} = 3$, Temperature = 25°C

17004-013

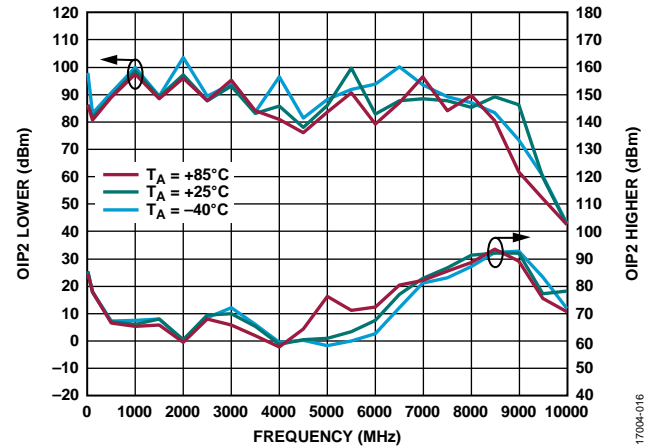

Figure 16. OIP2 Lower and OIP2 Higher vs. Frequency over Temperature, Supply = Nominal, $C_{PEAK} = 7$

17004-016

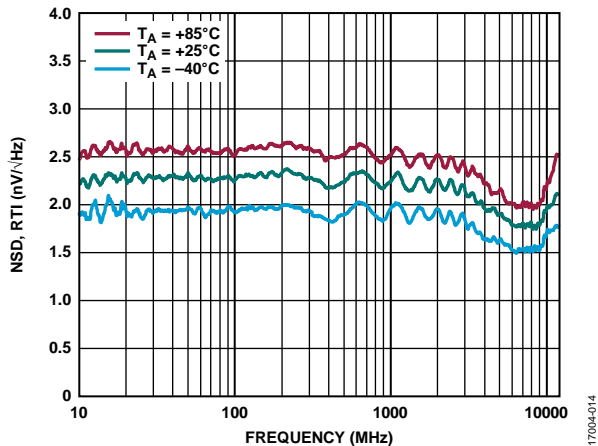

Figure 14. NSD, RTI vs. Frequency over Temperature, Supply = Nominal, $C_{PEAK} = 3$

17004-014

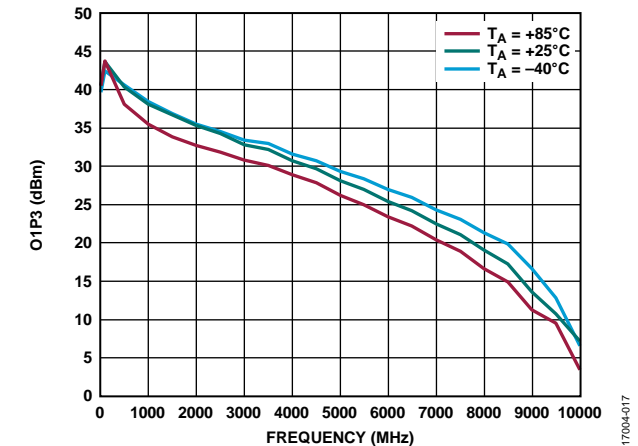

Figure 17. OIP3 vs. Frequency over Temperature, Supply = Nominal, $C_{PEAK} = 7$

17004-017

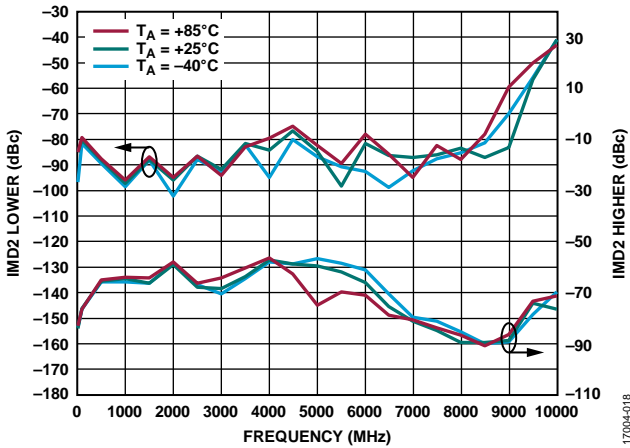

Figure 18. IMD2 Lower and IMD2 Higher vs. Frequency over Temperature, Supply = Nominal, $C_{PEAK} = 7$

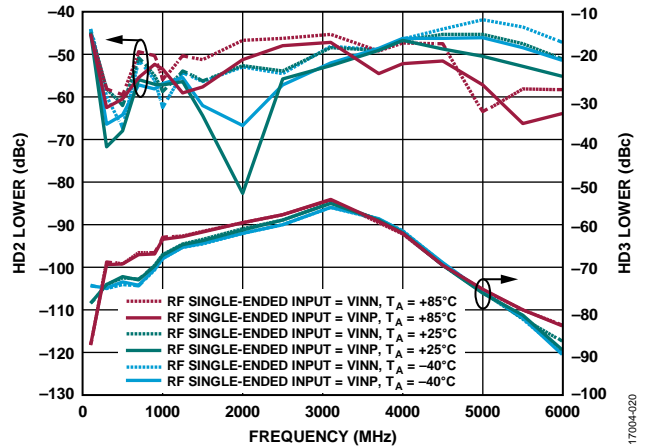

Figure 21. HD2 Lower and HD3 Lower vs. Frequency over Temperature, $C_{PEAK} = 7$

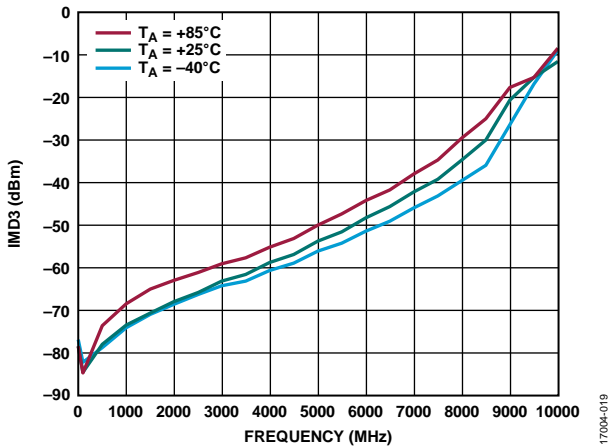

Figure 19. IMD3 vs. Frequency over Temperature, Supply = Nominal and $C_{PEAK} = 7$

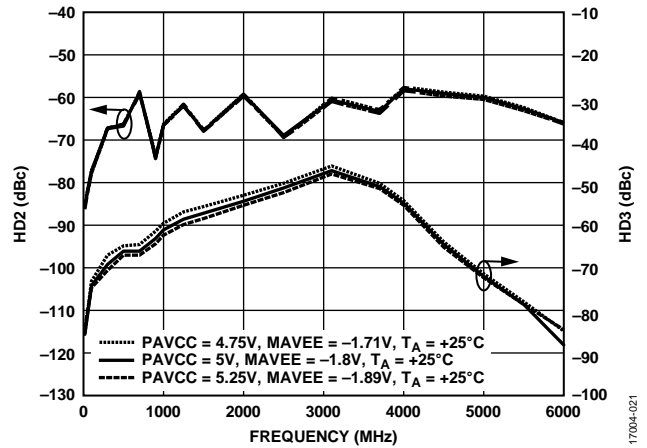

Figure 22. HD2 and HD3 vs. Frequency, Temperature = Nominal, Supply = Nominal, and $C_{PEAK} = 7$

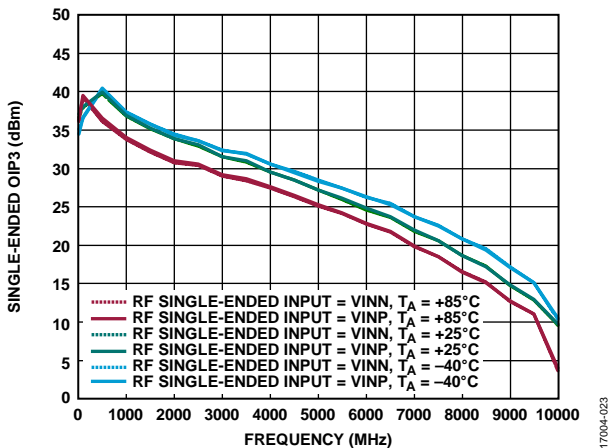

Figure 20. Single-Ended OIP3 vs. Frequency over Temperature

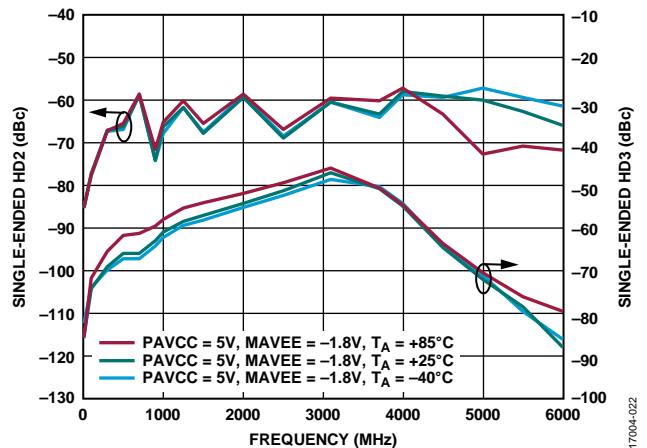

Figure 23. Single-Ended HD2 and HD3 vs. Frequency over Temperature

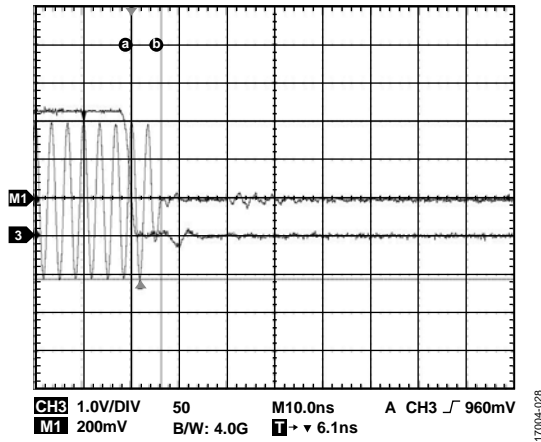

Figure 24. Enable Time Domain Response (Channel 3 (3) Is the Enable Voltage, and Marker 1 (M1) Is the Output Voltage)

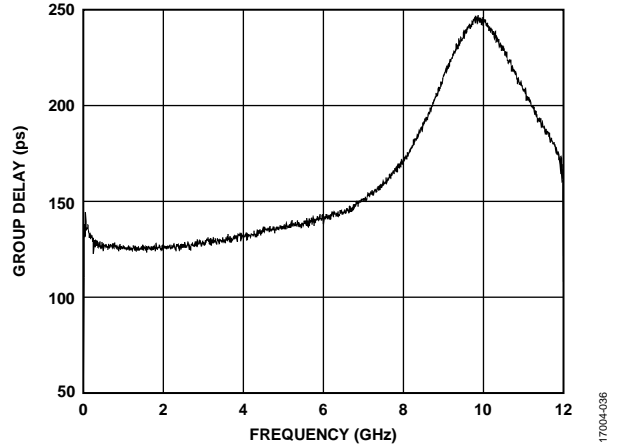

Figure 27. Group Delay vs. Frequency

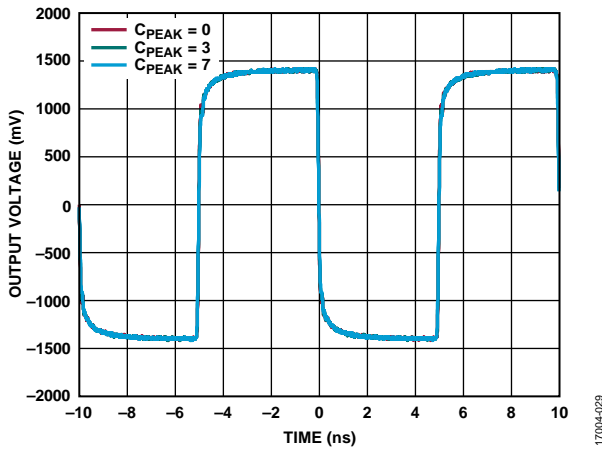

Figure 25. Large Signal Pulse Response

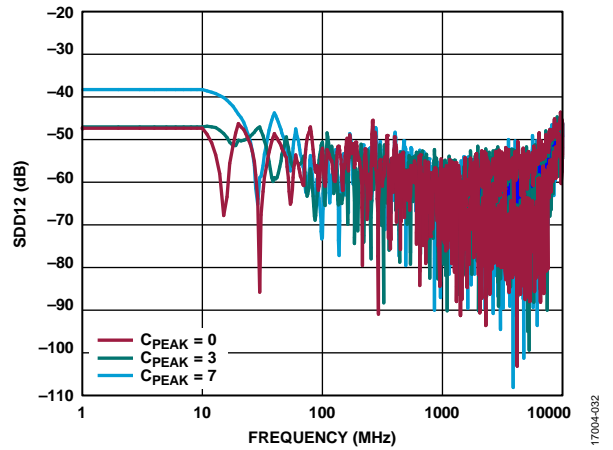

Figure 28. SDD12 vs. Frequency (Red: $C_{PEAK} = 0$, Green: $C_{PEAK} = 3$, and Blue: $C_{PEAK} = 7$)

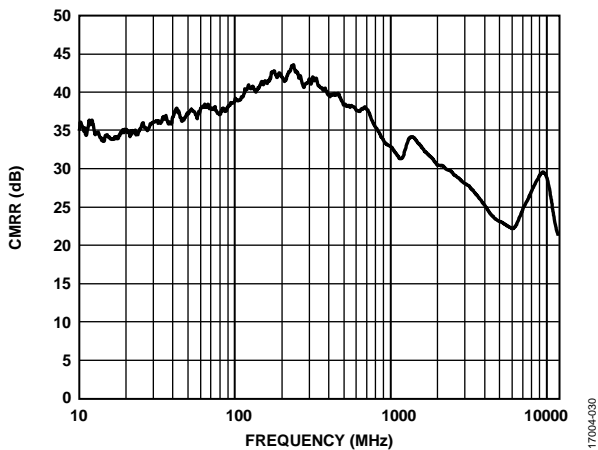

Figure 26. CMRR vs. Frequency

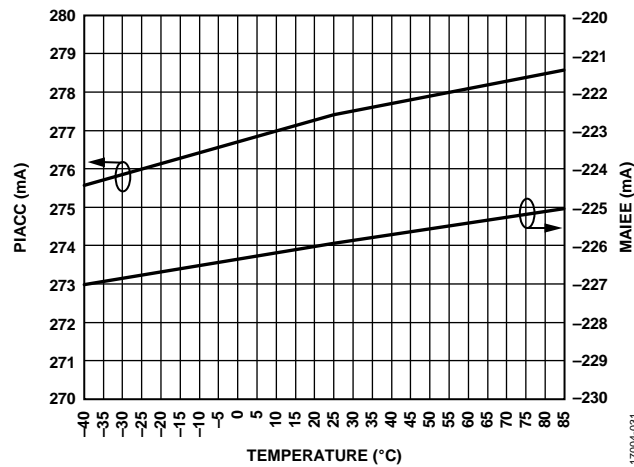

Figure 29. PAVCC Current (PIACC) and MAVEE Current (MAIEE) vs. Temperature

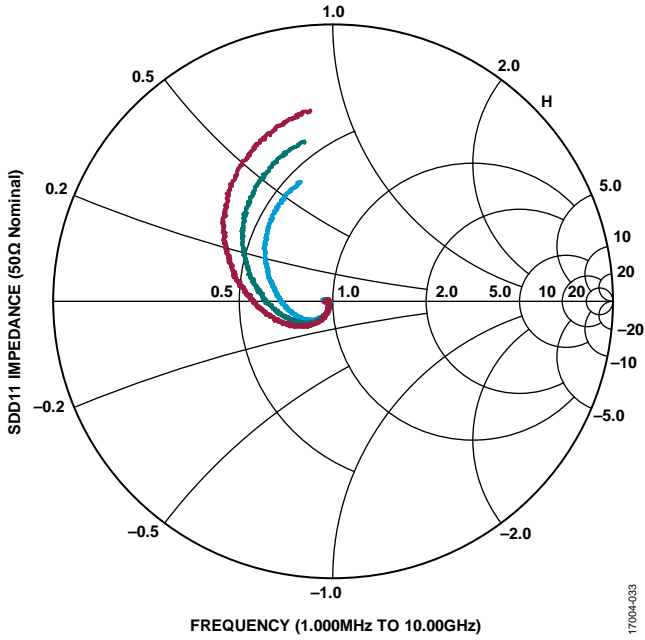

Figure 30. SDD11 Impedance vs. Frequency (Red: $C_{PEAK} = 0$, Green: $C_{PEAK} = 3$, and Blue: $C_{PEAK} = 7$) (SDD11 Is the Differential S11)

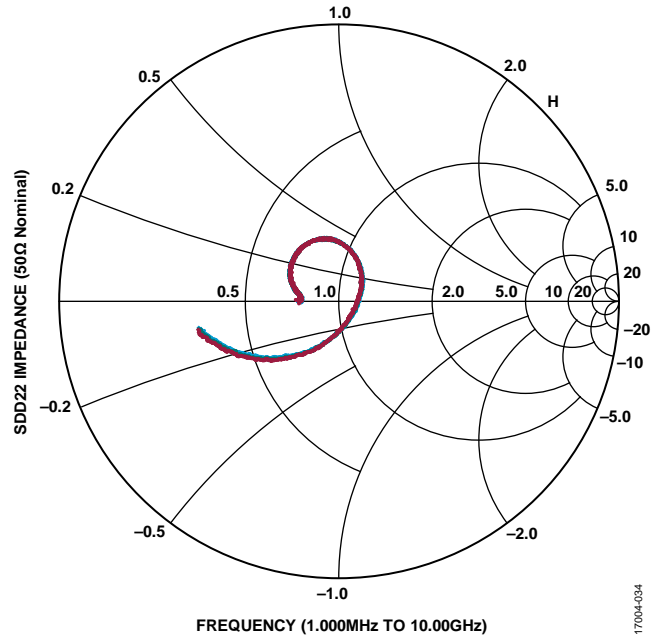

Figure 31. SDD22 Impedance vs. Frequency (Red: $C_{PEAK} = 0$, Green: $C_{PEAK} = 3$, and Blue: $C_{PEAK} = 7$)

THEORY OF OPERATION

The ADL5580 is a fixed voltage gain (10 dB), fully differential, high linearity amplifier, and ADC driver that operates on a dual power supply voltage, +5 V and -1.8 V.

The small signal -3 dB bandwidth is 10.0 GHz, and all of the integrated building blocks of the ADL5580 are programmable via the SPI.

RF INPUT AND OUTPUT WITH COMMON-MODE NETWORK

The input impedance is 100 Ω differential, and the output impedance is 50 Ω differential, which allows users to drive ADCs like the [AD9213](#) directly without any matching networks, that is at a 50 Ω differential input. For load conditions other than 50 Ω differential, external termination networks are required.

The input and output termination blocks have four operation modes that allow users to set the input and output common-mode operation through Register 0x100, Bits[7:0], see Table 7.

In Mode 00, the V_{CM} terminal must be provided externally on the input termination and the output termination blocks.

For Mode 01, the internal voltage generator (the voltage controlled by two bits) is activated, and the V_{CM} terminal input and output termination blocks are driven to the internal reference voltage. If the internal reference voltage and the connecting termination blocks have a different V_{CM} , the behavior of the system is undefined and must be avoided.

Mode 10 is identical to Mode 01 except that the VCMI and VCMO pins are driven to the internal reference voltage to convey the internal V_{CM} to the connecting termination blocks.

Use Mode 11 to set the internal V_{CM} termination to externally provide the voltage for the VCMx pins.

RF SIGNAL CHAIN

The ADL5580 provides another level of control to optimize flatness or wider bandwidth. In applications where flatness is critical, the ADL5580 offers flatness optimization at the expense of the operating bandwidth. However, if the operating

bandwidth is critical, the ADL5580 offers tuning options through the peaking control bits, PRG_CPEAK_1P8V (Register 0x101, Bits[6:4]).

Enable

The enable bits (EN_AMP_1P8V and EN_REF_1P8V) are located in Register 0x101, Bit 1 and Bit 0, respectively. These particular enable bits control enabling the amplifier (EN_AMP_1P8V) and the reference (EN_REF_1P8V). The ADL5580 can be enabled or disabled by using the EN pin (Pin 19), a real-time external pin with no SPI latency

PROGRAMMABILITY GUIDE

Viewing the register map at the highest level, the registers are subdivided into three memory map functional blocks (see Table 6). See Table 9 for a complete list of all the registers on the ADL5580.

Table 6. Memory Map Functional Blocks

Register Address	Functional Blocks
0x000 to 0x011	Analog Devices SPI configuration
0x100 to 0x101, 0x200	Signal path configuration, enable
0x300	Optional linearity optimization

SPI

The SPI of the ADL5580 allows the user to configure the device for specific functions or operations via a 3-wire SPI port. It includes enable blocks, the bias current level, transfer function peaking, change input and output termination block operation modes, and change input and output V_{CM} termination for certain operation modes. This SPI provides users with added flexibility and customization and consists of three control lines: SCLK, SDIO, and CS. The timing requirements for the SPI port are shown in Table 2.

The ADL5580 input logic level for the write cycle is with a 1.8 V logic level.

On a read cycle, the SDIO is configurable for 1.8 V (default) or 3.3 V output levels by setting the SPI_1P8_3P3_CTRL bit (Register 0x200, Bit 0).

Table 7. Common-Mode Setup Modes

Mode	Register 0x100, Bits[7:6]	Register 0x100, Bits[5:4]		Register 0x100, Bits[3:2]	Register 0x100, Bits[1:0]	
	Output V_{CM} (V)	Output Internal V_{CM}	VCMI Pin	Input V_{CM} (V)	Input Internal V_{CM}	VCMI Pin
00	0.41	Disabled	Disconnect	1.39	Disabled	Disconnect
01	0.51	Enabled	Disconnect	1.53	Enabled	Disconnect
10	0.60	Enabled	Export	1.67	Enabled	Export
11	0.70	Disabled	Import	1.80	Disabled	Import

APPLICATIONS INFORMATION

Figure 32 shows the basic connection diagram, and Table 8 describes the operation of the ADL5580.

The ADL5580 is sensitive to power supplies. Power rail voltages must be brought up and applied in a monotonically increasing

manner without any glitches to avoid issues with the internal digital logic.

The ADL5580 can be ac-coupled, as shown in Figure 32, or the device can be dc-coupled if within the specified input and output V_{CM} ranges.

BASIC CONNECTIONS

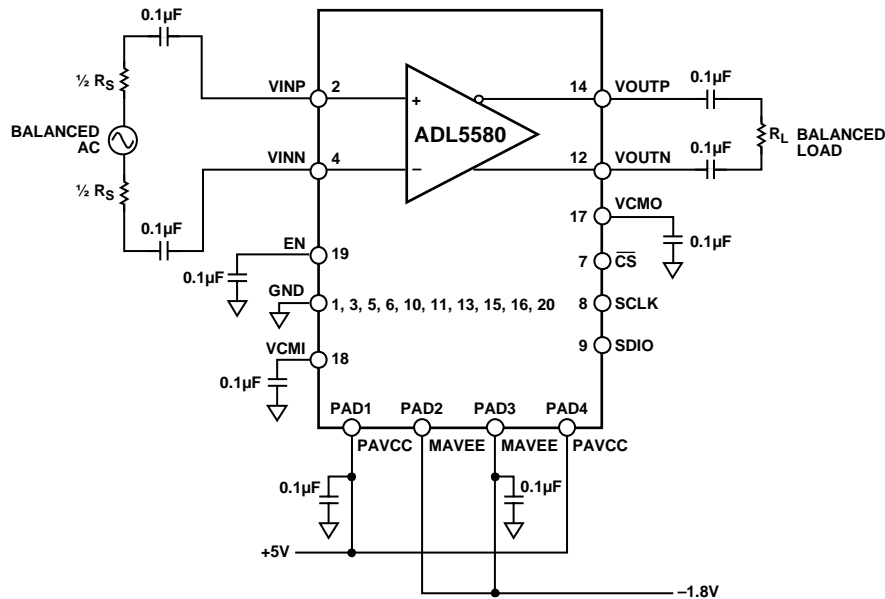

Figure 32. Basic Connection Diagram

Table 8. Basic Connections of the ADL5580

Functional Blocks	Pin No.	Mnemonic	Description	Basic Connection
5 V	PAD1, PAD4	PAVCC	Amplifier analog supply voltage, 5 V	Decouple each PAVCC pad via 100 pF, 1 µF capacitors to ground. Ensure that the decoupling capacitors are located close to the pads.
-1.8 V	PAD2, PAD3	MAVEE	Amplifier analog supply voltage, -1.8 V	Decouple each MAVEE pad via 100 pF, 1 µF capacitors to ground. Ensure that the decoupling capacitors are located close to the pads.
RF Input	2 4 18	VINP VINN VCM1	Differential RF inputs Positive RF Input Negative RF Input V_{CM} for the RF input signal	Connect these pins to a differential configuration.
RF Output	12 14 17	VOUTN VOUTP VCMO	Differential RF outputs Negative RF output Positive RF output V_{CM} for the RF output signal	Connect the RF outputs to a power meter, network analyzer, noise figure meter, or spectrum analyzer.
Serial Port	7 8 9	CS SCLK SDIO	Chip select active low SPI clock SPI data input output	1.8 V to 3.3 V tolerant logic levels. 1.8 V to 3.3 V tolerant logic levels. 1.8 V to 3.3 V tolerant logic levels.
AMP Control	19	EN	Amplifier enable	1.8 V to 3.3 V tolerant logic levels.
Ground	1, 3, 5, 6, 10, 11, 13, 15, 16, 20	GND	Ground	Connect the GND pins to the ground of the PCB.

INPUT AND OUTPUT INTERFACING

Differential Input to Differential Output

The ADL5580 can be configured as a differential input to differential output driver (see Figure 33). The 50 Ω resistors, R1 and R2, combined with the 100 Ω input impedance provide a 50 Ω input match with the 1:1 balun. The input and output 0.1 μF capacitors isolate the common-mode bias voltage (V_{BIAS}) on input and output pins from the source and balanced load. The load is 50 Ω to provide the expected ac performance.

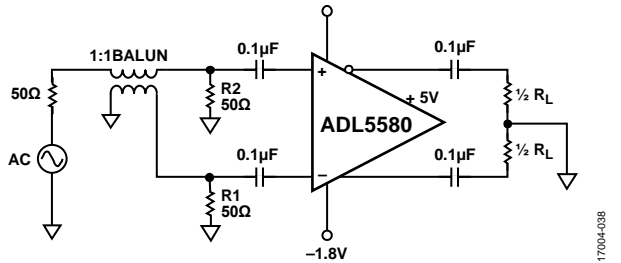

Figure 33. Differential Input to Differential Output Configuration

The differential gain of the ADL5580 is dependent on the source impedance and load, as shown in Figure 34.

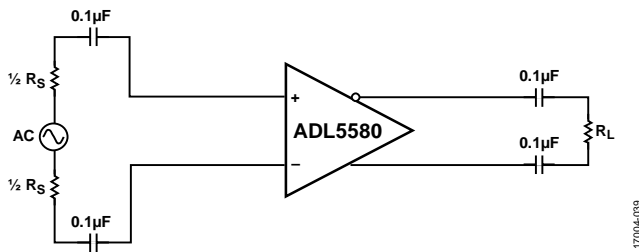

Figure 34. Differential Input Loading Circuit

Single-Ended Input to Differential Output

The ADL5580 can also be configured in a single-ended input to differential output configuration. In this configuration, the gain of the device is reduced due to the application of the signal to only one side of the amplifier. The input and output 0.1 μF capacitors isolate the V_{CM} on input and output pins from the source and balanced load.

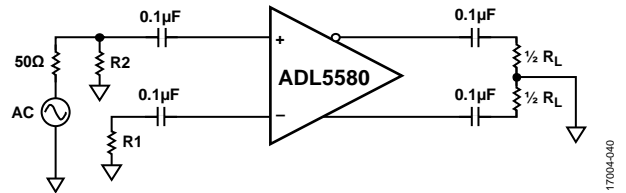

Figure 35. Single-Ended Input to Differential Output Configuration

The ADL5580 is a high output linearity, fixed gain dc-coupled amplifier for multigigasample ADC interfacing. The open-loop architecture anticipates a 50 Ω differential dc output load. The maximum linear output swing is optimized for 1.4 V p-p differential.

LAYOUT

Solder the four exposed power supply pads on the underside of the ADL5580 to a low thermal and electrical impedance power plane. These pads are typically soldered to exposed opens in the solder mask on the evaluation board. Notice the use of 4 via holes on each exposed power pad of the ADL5580-EVALZ. Connect these power vias to power layers on the evaluation board to maximize heat dissipation from the device package. For more information on the evaluation board, see the ADL5580-EVALZ product page.

Ensure that the decoupling capacitors are located close to the supply voltage pins.

REGISTER SUMMARY

Table 9.

Reg	Name	Bits	Bit 7	Bit 6	Bit 5	Bit 4	Bit 3	Bit 2	Bit 1	Bit 0	Reset	R/W	
0x000	ADI_SPI_CONFIG	[7:0]	SOFTRESET_	LSB_FIRST_	ENDIAN_	SDOACTIVE_	SDOACTIVE	ENDIAN	LSB_FIRST	SOFTRESET	0x00	R/W	
0x001	REG_0X0001	[7:0]	SINGLE_ INTSTRUCTION	CSB_STALL	MASTER_ SLAVE_ RB	RESERVED		SOFT_RESET		MASTER_ SLAVE_ TRANSFER	0x00	R/W	
0x003	CHIPTYPE	[7:0]	CHIPTYPE									0x01	R
0x004	PRODUCT_ID_L	[7:0]	PRODUCT_ID_L									0x03	R
0x005	PRODUCT_ID_H	[7:0]	PRODUCT_ID_H									0x00	R
0x00A	SCRATCHPAD	[7:0]	SCRATCHPAD									0x00	R/W
0x00B	SPI_REV	[7:0]	SPI_REV									0x00	R
0x010	VARIANT_FEOL	[7:0]	FEOL				VARIANT				0x00	R	
0x011	BEOL_SIF	[7:0]	SIF				BEOL				0x00	R	
0x100	GEN_CTL0	[7:0]	PRG_OTRM_1P8V		MS_OTRM_1P8V		PRG_ITRM_1P8V		MS_ITRM_1P8V		0x78	R/W	
0x101	GEN_CTL1	[7:0]	RESERVED	PRG_CPEAK_1P8V			RESERVED		EN_AMP_1P8V	EN_REF_1P8V	0x33	R/W	
0x200	SPI_CTL	[7:0]	RESERVED							SPI_1P8_3P3_CTRL		0x01	R/W

REGISTER DETAILS

Address: 0x000, Reset: 0x00, Name: ADI_SPI_CONFIG

Table 10. Bit Descriptions for ADI_SPI_CONFIG

Bit(s)	Bit Name	Description	Reset	Access
7	SOFTRESET_	Soft Reset 0: reset asserted 1: reset not asserted	0x00	R/W
6	LSB_FIRST_	LSB First 0: LSB first 1: MSB first	0x00	R/W
5	ENDIAN_	Endian 0: little endian 1: big endian	0x00	R/W
4	SDOACTIVE_	SDO Active 0: SDO inactive 1: SDO active	0x00	R/W
3	SDOACTIVE	SDO Active 0: SDO inactive 1: SDO active	0x00	R/W
2	ENDIAN	Endian 0: little endian 1: big endian	0x00	R/W
1	LSB_FIRST	LSB First 0: LSB first 1: MSB first	0x00	R/W
0	SOFTRESET	Soft Reset 0: reset asserted 1: reset not asserted	0x00	R/W

Address: 0x001, Reset: 0x00, Name: REG_0X0001

Table 11. Bit Descriptions for REG_0X0001

Bit(s)	Bit Name	Description	Reset	Access
7	SINGLE_INTSTRUCTION	Single Instruction	0x00	R/W
6	CSB_STALL	Chip Select (\overline{CS}) Stall	0x00	R/W
5	MASTER_SLAVE_RB	Master Slave Read Back (RB)	0x00	R/W
[4:3]	RESERVED	Reserved	0x00	R
[2:1]	SOFT_RESET	Soft Reset	0x00	R/W
0	MASTER_SLAVE_TRANSFER	Master Slave Transfer	0x00	R/W

Address: 0x003, Reset: 0x01, Name: CHIPTYPE

Table 12. Bit Descriptions for CHIPTYPE

Bit(s)	Bit Name	Description	Reset	Access
[7:0]	CHIPTYPE	Chip Type, Read Only	0x01	R

Address: 0x004, Reset: 0x03, Name: PRODUCT_ID_L

Table 13. Bit Descriptions for PRODUCT_ID_L

Bit(s)	Bit Name	Description	Reset	Access
[7:0]	PRODUCT_ID_L	Product_ID_L, Lower 8 Bits	0x03	R

Address: 0x005, Reset: 0x00, Name: PRODUCT_ID_H

Table 14. Bit Descriptions for PRODUCT_ID_H

Bit(s)	Bit Name	Description	Reset	Access
[7:0]	PRODUCT_ID_H	Product_ID_H, Higher 8 Bits	0x00	R

Address: 0x00A, Reset: 0x00, Name: SCRATCHPAD

Table 15. Bit Descriptions for SCRATCHPAD

Bit(s)	Bit Name	Description	Reset	Access
[7:0]	SCRATCHPAD	Scratch Pad	0x00	R/W

Address: 0x00B, Reset: 0x00, Name: SPI_REV

Table 16. Bit Descriptions for SPI_REV

Bit(s)	Bit Name	Description	Reset	Access
[7:0]	SPI_REV	SPI Register Map Revision	0x00	R

Address: 0x010, Reset: 0x00, Name: VARIANT_FEOL

Table 17. Bit Descriptions for VARIANT_FEOL

Bit(s)	Bit Name	Description	Reset	Access
[7:4]	FEOL	Front End of Line (FEOL)	0x00	R
[3:0]	VARIANT	Variant	0x00	R

Address: 0x011, Reset: 0x00, Name: BEOL_SIF

Table 18. Bit Descriptions for BEOL_SIF

Bit(s)	Bit Name	Description	Reset	Access
[7:4]	SIF	Stress Intensity Factor (SIF) Version	0x00	R
[3:0]	BEOL	Back End of Line (BEOL) Version	0x00	R

Address: 0x100, Reset: 0x78, Name: GEN_CTL0

Table 19. Bit Descriptions for GEN_CTL0

Bit(s)	Bit Name	Description	Reset	Access
[7:6]	PRG_OTRM_1P8V	These bits set up the output V_{CM} .	0x1	R/W
[5:4]	MS_OTRM_1P8V	These bits set V_{CM} to internal or external and set the VC _{MO} pin definition.	0x3	R/W
[3:2]	PRG_ITRM_1P8V	These bits set up the input V_{CM} .	0x2	R/W
[1:0]	MS_ITRM_1P8V	These bits set V_{CM} to internal or external and set the VC _{MI} pin definition.	0x0	R/W

Address: 0x101, Reset: 0x33, Name: GEN_CTL1

Table 20. Bit Descriptions for GEN_CTL1

Bit(s)	Bit Name	Description	Reset	Access
7	RESERVED	Reserved.	0x0	R
[6:4]	PRG_CPEAK_1P8V	These bits set up C_{PEAK} .	0x3	R/W
[3:2]	RESERVED	Reserved.	0x0	R
1	EN_AMP_1P8V	Enable Amplifier Block.	0x1	R/W
0	EN_REF_1P8V	Enable Reference Block.	0x1	R/W

Address: 0x200, Reset: 0x01, Name: SPI_CTL

Table 21. Bit Descriptions for SPI_CTL

Bit(s)	Bit Name	Description	Reset	Access
[7:1]	RESERVED	Reserved	0x0	R
0	SPI_1P8_3P3_CTRL	SPI Supply Control 0: 1.8 V readback 1: 3.3 V readback	0x1	R/W

OUTLINE DIMENSIONS

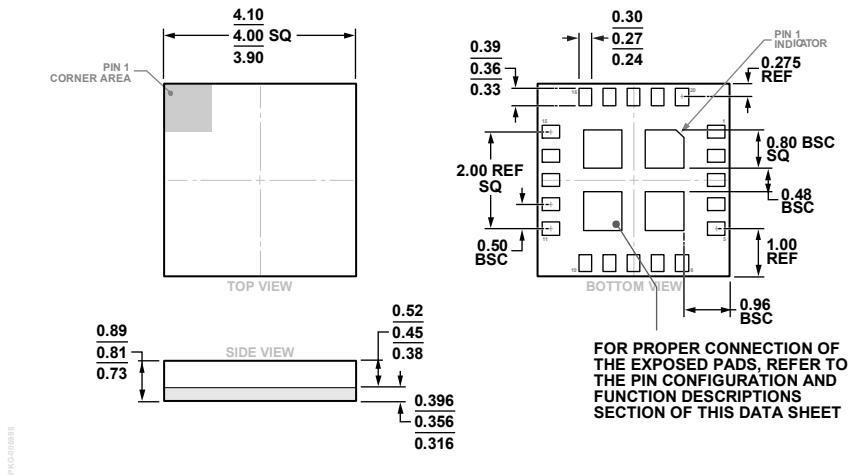

Figure 36. 20-Terminal Land Grid Array [LGA]
(CC-20-7)
Dimensions shown in millimeters

ORDERING GUIDE

Model ¹	Temperature Range	Package Description	Package Option
ADL5580BCCZ	-40°C to +85°C	20-Terminal Land Grid Array [LGA]	CC-20-7
ADL5580BCCZ-R7	-40°C to +85°C	20-Terminal Land Grid Array [LGA]	CC-20-7
ADL5580-EVALZ		Evaluation Board	
AD-FMCADC20-DC-EBZ		DC-Coupled Combination AD9213 and ADL5580 Reference Design	
AD-FMCADC20-EBZ		AC-Coupled Combination AD9213 and ADL5580 Reference Design	

¹ Z = RoHS-Compliant Part.

Looking for pricing, stock, or lifecycle information?

Click below to explore more details on WIN SOURCE:

 [View ADL5580BCCZ-R7 on WIN SOURCE](#)

 [Analog Devices Inc. Information](#)

Optimize Your Supply Chain with WIN SOURCE Solutions

-  Global Sourcing Solution
-  Obsolete Management
-  Cost Control Management
-  Shortage Management
-  Alternative Solution
-  Excess Inventory Management