

W-LAN + Bluetooth Module Data Sheet

Qualcomm Chipset
for 802.11a/b/g/n/ac + Bluetooth 5.0 (Dual)

Tentative Part Number: **LBEE5ZZ1PJ-TEMP**

The revision history of the product specification

Revised Date	Revision Code	Revised Page	Revised Item	Change Reason
July 25, 2018	-	-	-	First release
Aug 16, 2018	A	10 12 16~17	-Revised spec of t_{a2} -Revised spec of VOL -Added UHS SDIO timing requirement	Revised/Added
Sep 13, 2018	B	8 12	-Revise Operating condition -Revise Digital I/O Requirement	Revised
Sep 29, 2018	C	7	-Revised Marking	Revised
Nov 3, 2018	D	4 7 37~44 3 25~26	-Added Radio certification info -Added the module picture -Added Appendix -Updated BT version -Revised DC/RF Characteristics for Bluetooth/BLE	Added
Dec 29, 2018	E	- 38/41	-Removed 2.4GHz 11ac description -Amended typo in Appendix	Revised
Jan 21, 2019	F	24/25 28	-Updated the table for Bluetooth/BLE -Amend Dimension of Reel	Revised
Mar 6, 2019	G	4 17	-Add BT SIG QDID -Amend typo in table of Output timing (SDR104)	Add/Revised

TABLE OF CONTENTS

1.	SCOPE.....	3
2.	KEY FEATURE	3
3.	Manufacturing site	3
4.	Part Number	3
5.	RoHS Compliance	3
6.	Block Diagram	3
7.	Certification Information	4
7.1.	Radio Certification	4
8.	DIMENSIONS, MARKING AND TERMINAL CONFIGURATIONS	4
8.1.	Dimensions	4
8.2.	Pin Layout and PIN Descriptions	5
8.3.	Marking.....	7
9.	ABSOLUTE MAXIMUM RATINGS ^{*1)}	8
10.	OPERATING CONDITION ^{*2)}	8
11.	External low-power 32.768 kHz clock.....	9
12.	POWER SEQUENCE Timing	10
12.1.	Case 1: 3.3 V power down after 1.8 V.....	10
12.2.	Case 2: 1.8 V power down after 3.3 V.....	11
12.3.	Case 3: All power rails supplied with 3.3 V	12
13.	Digital I/O Requirements	12
14.	INTERFACE TIMING	13
14.1.	Bluetooth UART Timing	13
14.1.1.	UART transmit Timing.....	13
14.1.2.	UART Receiver Timing	13
14.2.	I ² S Timing	13
14.2.1.	I ² S Transmitter Timing.....	14
14.2.2.	I ² S Receiver Timing.....	14
14.3.	SDIO Timing.....	15
14.3.1.	SDIO Default Mode Timing.....	15
14.3.2.	SDIO High-Speed Mode Timing.....	16
14.3.1.	SDIO UHS mode Timing	16
15.	DC / RF Characteristics.....	18
15.1.	DC/RF Characteristics for IEEE802.11b - 2.4GHz	18
15.2.	DC/RF Characteristics for IEEE802.11g - 2.4GHz	19
15.3.	DC/RF Characteristics for IEEE802.11n - 2.4GHz	20
15.4.	DC/RF Characteristics for IEEE802.11a - 5GHz	21
15.5.	DC/RF Characteristics for IEEE802.11n - 5GHz	22
15.6.	DC/RF Characteristics for IEEE802.11ac - 5GHz.....	23
15.7.	DC/RF Characteristics for Bluetooth	24
15.8.	DC/RF Characteristics for Bluetooth (LE).....	25
16.	LAND PATTERN (TOP VIEW)	26
17.	REFERENCE CIRCUIT.....	27
18.	TAPE AND REEL PACKING.....	28
19.	NOTICE.....	32
19.1.	Storage Conditions:	32
19.2.	Handling Conditions:	32
19.3.	Standard PCB Design (Land Pattern and Dimensions):.....	32
19.4.	Notice for Chip Placer:	32
19.5.	Soldering Conditions:	33
19.6.	Cleaning:	33
19.7.	Operational Environment Conditions:.....	33
19.8.	Input Power Capacity:.....	34
20.	PRECONDITION TO USE OUR PRODUCTS	35

Please be aware that an important notice concerning availability, standard warranty and use in critical applications of Murata products and disclaimers thereto appears at the end of this specification sheet.

1. SCOPE

This specification is applied to the IEEE802.11a/b/g/n/ac W-LAN + Bluetooth 5.0 combo module.

2. KEY FEATURE

- Chipset: QCA9377-3
- Size: 7.2 x 7.4 x 1.25 (max) mm
- Weight: 0.15g/pc
- PCB w/ shielded resin mold module
- IEEE802.11a/b/g/n/ac dual band 2.4G/5G
- Supports BT5.0 (Except Options)
- SDIO 3.0 supporting SDR104 (WLAN), UART/PCM (Bluetooth)
- Lead Free Module

3. Manufacturing site

Company name:
Shenzhen Murata Technology Co., Ltd.

Address:
15 Cuijing Road, Longtian Street, Shenzhen Grand Industrial Zone, PingShan District, Shenzhen, Guangdong, 518118 China

4. Part Number

Ordering Part Number	Description
LBEE5ZZ1PJ-TEMP	In case of sample order

5. RoHS Compliance

This module is compliant with the RoHS directive.

6. Block Diagram

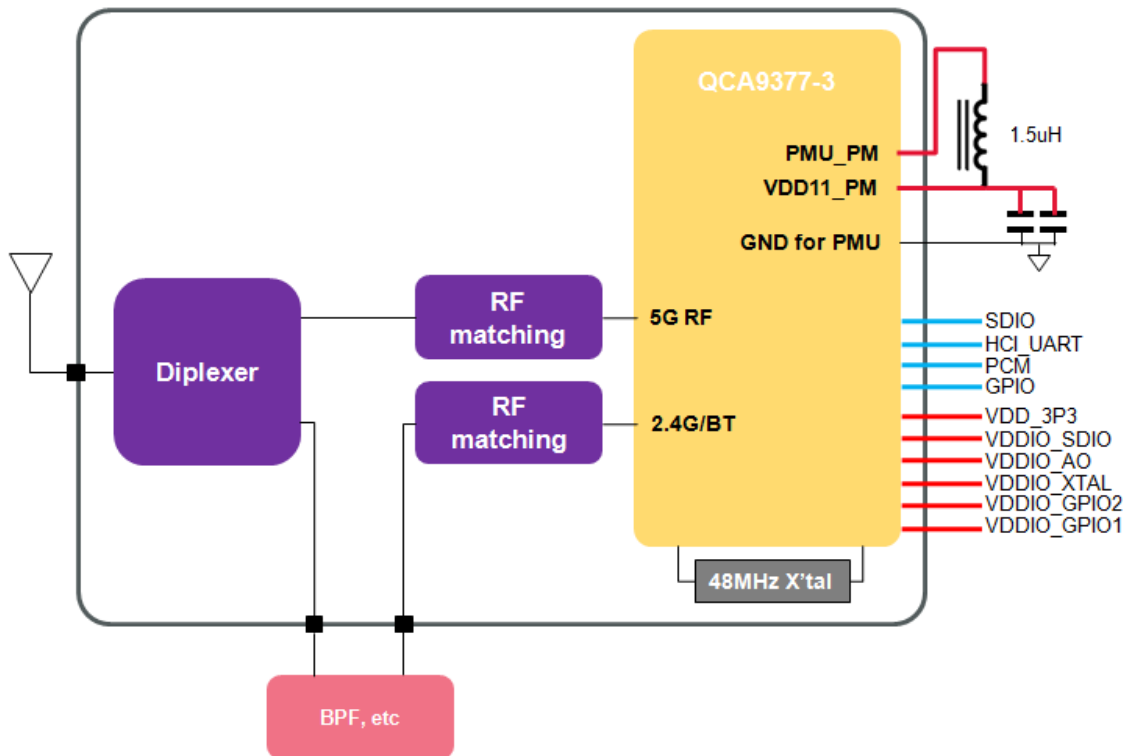

7. Certification Information

7.1. Radio Certification

USA/Canada

FCC ID	VPYLBEE5ZZ1PJ
IC	772C-LBEE5ZZ1PJ

*Please follow installation manual in Appendix

Europe

EN300 328 v2.1.1, Draft EN 300 328 v2.2.0, EN301 893 v2.1.1 and Final draft EN300 440 v2.2.1 are prepared.

Japan

Certification number: 001-P01296

7.2. BT SIG QDID

QDID: 127073 (Controller Subsystem)

Notes:

Above QDID can be referred in case that LE packet length is less than TX: 123Bytes / RX: 37Bytes.

8. DIMENSIONS, MARKING AND TERMINAL CONFIGURATIONS

8.1. Dimensions

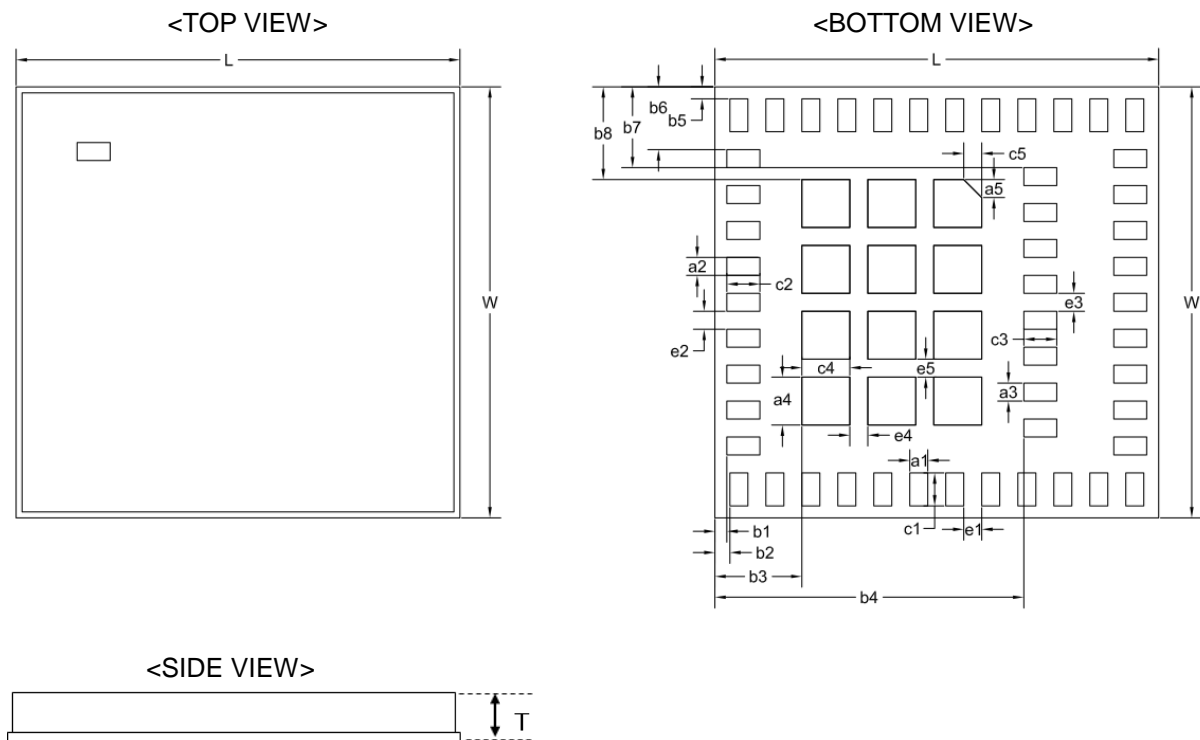

Table 1 Dimension (Unit: mm)

Mark	Dimension	Mark	Dimension	Mark	Dimension
L	7.40±0.20	W	7.20±0.20	T	1.25 max
a1	0.30±0.10	a2	0.30±0.10	a3	0.30±0.10
a4	0.80±0.10	a5	0.30±0.10	b1	0.20±0.15
b2	0.25±0.15	b3	1.45±0.15	b4	5.15±0.15
b5	0.20±0.15	b6	1.05±0.15	b7	1.35±0.15
b8	1.55±0.15	c1	0.55±0.10	c2	0.55±0.10
c3	0.55±0.10	c4	0.80±0.10	c5	0.30±0.10

e1	0.30±0.10	e2	0.30±0.10	e3	0.30±0.10
e4	0.30±0.10	e5	0.30±0.10		

(unit : mm)

Co-planarity: 100um Max.

8.2. Pin Layout and PIN Descriptions

Top View

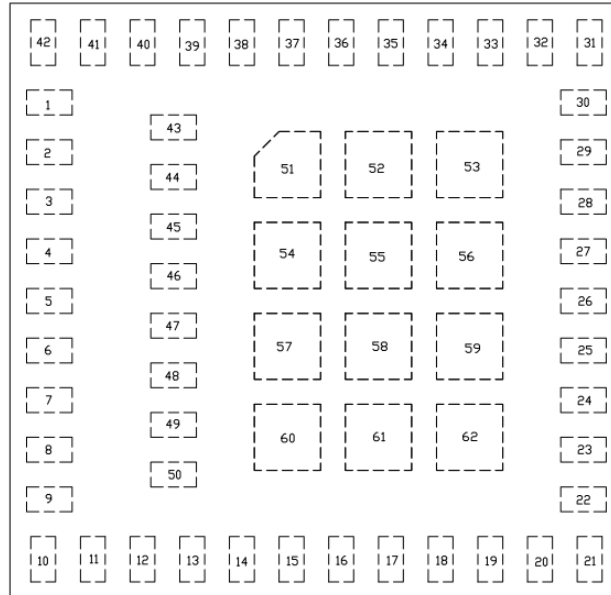
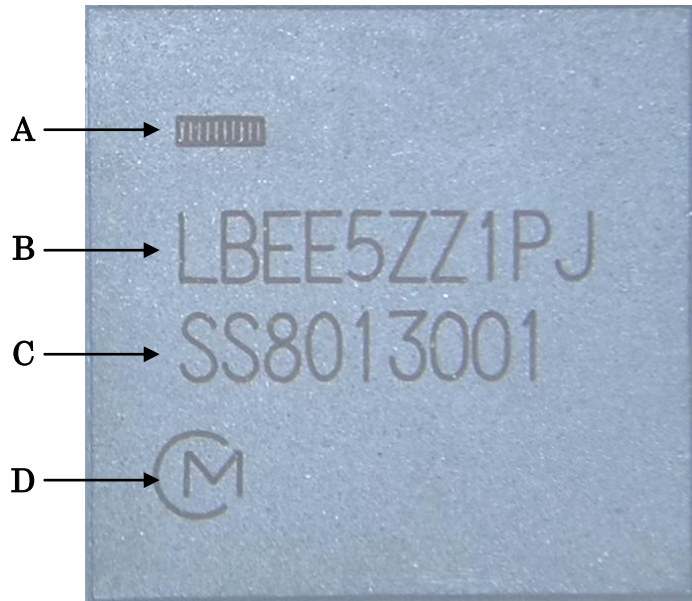

Table 2 Terminal Configurations

Pin NO.	Terminal Name	Type	VDDIO or pad voltage	Connection to IC terminal	Description
1	GND	Ground	-	-	Ground
2	VBUCK_GND_PM	Ground	-	VBUCK_GND_PM	Ground for internal 1.1 V regulator
3	PWM_PM	O	1.1V	PWM_PM	SWREG PMU 1.1V output.
4	VDD11_PM	I	1.1V	VDD11_PM	1.1 V voltage feedback to SWREG PMU.
5	GND	Ground	-	-	Ground
6	SDIO_DATA3	I/O	VDDIO_SDIO	SDIO_D3	SDIO data bus D3
7	SDIO_DATA2	I/O	VDDIO_SDIO	SDIO_D2	SDIO data bus D2
8	SDIO_DATA1	I/O	VDDIO_SDIO	SDIO_D1	SDIO data bus D1
9	SDIO_DATA0	I/O	VDDIO_SDIO	SDIO_D0	SDIO data bus D0
10	SDIO_CMD	I	VDDIO_SDIO	SDIO_CMD	SDIO CMD line signal
11	SDIO_CLK	OD ⁽¹⁾	VDDIO_SDIO	SDIO_CLK	SDIO clock signal
12	VDDIO_SDIO	Power	1.8V or 3.3V	VDDIO_SDIO	Voltage supply for SDIO
13	SDIO_INTERRUPT_L	O	VDDIO_SDIO	SDIO_INTERRUPT_L	SDIO interrupt signal
14	GND	Ground	-	-	Ground
15	32KHz_CLK_IN	I	VDDIO_GPIO2	LF_CLK_IN	External low-power 32.768 kHz clock input
16	VDDIO_GPIO2	Power	1.8V or 3.3V	VDDIO_GPIO2	Voltage supply
17	HCI_UART_WAKEHOST	OD ⁽¹⁾	VDDIO_GPIO2	HCI_UART_WAKEHOST	Bluetooth wakeup host. Active high
18	WLAN_RF_KILL_L	I	VDDIO_GPIO2	WLAN_RFKILL_L	Turn off WLAN RF analog and front-end. Active low.
19	GND	Ground	-	-	Ground
20	2G_WIFI/BT_RF_OUT	A,O	-	-	2G WIFI and BT output
21	GND	Ground	-	-	Ground
22	2G_WIFI/BT_RF_IN	A, I	-	-	2G WIFI and BT input

23	GND	Ground	-	-	Ground
24	ANT	A, I/O	-	-	RF Transmit / Receive Antenna
25	GND	Ground	-	-	Ground
26	3D_FRAME_SYNC	I	VDDIO_GPIO1	3D_FRAME_SYNC	Frame sync signal from TV to sync with 3D glass via Bluetooth.
27	HCI_UART_RXD	I	VDDIO_GPIO1	HCI_UART_RXD	UART RXD signal
28	HCI_UART_TXD	O	VDDIO_GPIO1	HCI_UART_TXD	UART TXD signal
29	HCI_UART_RTS	O	VDDIO_GPIO1	HCI_UART_RTS	UART RTS signal
30	HCI_UART_CTS	I	VDDIO_GPIO1	HCI_UART_CTS	UART CTS signal
31	PCM_CLK	I	VDDIO_GPIO1	BT_I2S_SCK	Bluetooth PCM_CLK signal
32	PCM_SYNC	I/O	VDDIO_GPIO1	BT_I2S_WS	Bluetooth PCM_SYNC signal
33	PCM_IN	OD ⁽¹⁾	VDDIO_GPIO1	BT_I2S_SDI	Bluetooth PCM_IN signal
34	PCM_OUT	O	VDDIO_GPIO1	BT_I2S_SDO	Bluetooth PCM_OUT signal
35	GND	Ground	-	-	Ground
36	VDDIO_XTAL	Power	1.8V or 3.3V	VDDIO_XTAL	Voltage supply for XTAL
37	VDDIO_GPIO1	Power	1.8V or 3.3V	VDDIO_GPIO1	Voltage supply
38	GND	Ground	-	-	Ground
39	WLAN_EN	I	VDDIO_AO	WL_EN	WLAN enable. Active high
40	BT_EN	I	VDDIO_AO	BT_EN	Bluetooth enable. Active high
41	VDD_3P3	Power	3.3V	VDD33_PM	3.3 V input voltage
42	VDDIO_AO	Power	1.8V or 3.3V	VDDIO_AO_PM	Always-on I/O supply for power management and real-time clock. This supply must be present if any other supply is present.
43	GND	Ground	-	-	Ground
44	LTE_UART_RXD	I	VDDIO_GPIO1	LTE_UART_RXD	LTE coexistence signal. LTE_UART_RXD or LTE_FS.
45	LTE_UART_TXD	O	VDDIO_GPIO1	LTE_UART_TXD	LTE co- existence signal. LTE_UART_TXD or LTE_PRI.
46	CLK_REQ	O	VDDIO_GPIO1	CLK_REQ	Clock request output
47	DBG_UART_TXD	OD ⁽¹⁾	VDDIO_AO	GPIO[19]	DBG_UART_TXD
48	DBG_UART_RXD	OD ⁽¹⁾	VDDIO_GPIO2	GPIO[18]	DBG_UART_RXD
49	QOW	OD ⁽¹⁾	VDDIO_GPIO2	QOW	This signal can be used to enable for external Wireless charging UART circuit.
50~ 62	GND	Ground	-	-	Ground

(1) OD means this PIN is a digital output signal with open drain, an external pull-up or pull-down resistor is needed when this PIN is used.

8.3. **Marking**



Marking	Meaning
A	Pin 1 Marking
B	Module P/N
C	Inspection Number
D	Murata Logo

9. ABSOLUTE MAXIMUM RATINGS^{*1)}

Parameter		min.	max.	Unit
Storage Temperature		-40	85	deg.C
Supply Voltage	VDD_3P3	-0.3	3.65	V
	VDDIO_SDIO	-0.3	3.6	V
	VDDIO_GPIO1			
	VDDIO_GPIO2			
	VDDIO_XTAL			
VDDIO_AO				

^{*1)} Stresses in excess of the absolute ratings may cause permanent damage. Functional operation is not implied under these conditions. Exposure to absolute ratings for extended periods of time may adversely affect reliability. No damage assuming only one parameter is set at limit at a time with all other parameters are set within operating condition.

10. OPERATING CONDITION^{*2)}

Parameter		min.	typ.	max.	unit
Operating Temperature		-20	-	70	deg.C
Specification Temperature range		-20	25	60	deg.C
Supply Voltage	VDD_3P3	3.135	3.3	3.465	V
	VDDIO_SDIO	1.71	1.8 or 3.3	3.46	V
	VDDIO_GPIO1				
	VDDIO_GPIO2				
	VDDIO_XTAL				
VDDIO_AO					

^{*2)} Functionality is guaranteed but the specifications require the derating at over-temperatures, over-voltage condition.

11. External low-power 32.768 kHz clock

The 32 kHz clock is used in low-power modes such as IEEE power-save and sleep. It serves as a timer to determine when to wake up to receive beacons in various power-save schemes and to maintain basic logic operations when in sleep.

Type1PJ module does not require an external 32 kHz clock. By default, Type1PJ module utilizes its internal 200 kHz clock shared with the WLAN and BT subsystem.

If the end application has a more accurate 32 kHz clock, then it can be supplied externally via the LF_CLK_IN pin. The LF_CLK_IN pin must be grounded when using the default internal clock mode. If an external 32 kHz clock is used, the requirements are:

Symbol	Description	Min	Typ	Max	Unit
CK1	Clock rate	-	32.768	-	kHz
CK2	Fall time	1	-	100	ns
CK3	Rise time	1	-	100	ns
CK4	Duty cycle (high-to-low ratio)	15	-	85	%
CK5	Frequency stability	-200	-	200	ppm
CK6	Input high voltage	$0.8 \times VDDIO_GPIO2$	-	$VDDIO_GPIO2 + 0.2$	V
CK7	Input low voltage	-0.3	-	$0.2 \times VDDIO_GPIO2$	V

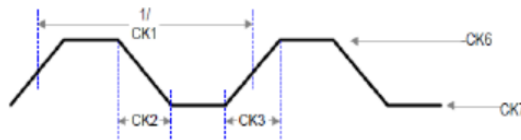

12. POWER SEQUENCE Timing

12.1. Case 1: 3.3 V power down after 1.8 V

If the battery source can be removed from the end user device (battery removed, AC/DC plugged in), this is the recommended power sequence. It will avoid violating the power off sequence by allowing the 3.3 V rail to shut down after the 1.8 V rail.

Notes:

1. VDDIO_GPIO voltage should match VIO voltage from the host. In some applications, VDDIO_GPIO may connected to 3.3 V upon Host VIO voltage.
2. In this case, both WLAN_EN and BT_EN on the 1PJ are at 3.3 V due to using the VDD_AO power rail. If the host VIO voltage is 1.8 V, it must have level shifters to interface with host.
3. All host interface signals must stay floating or low before valid power on sequence (WLAN_EN and BT-EN goes high).

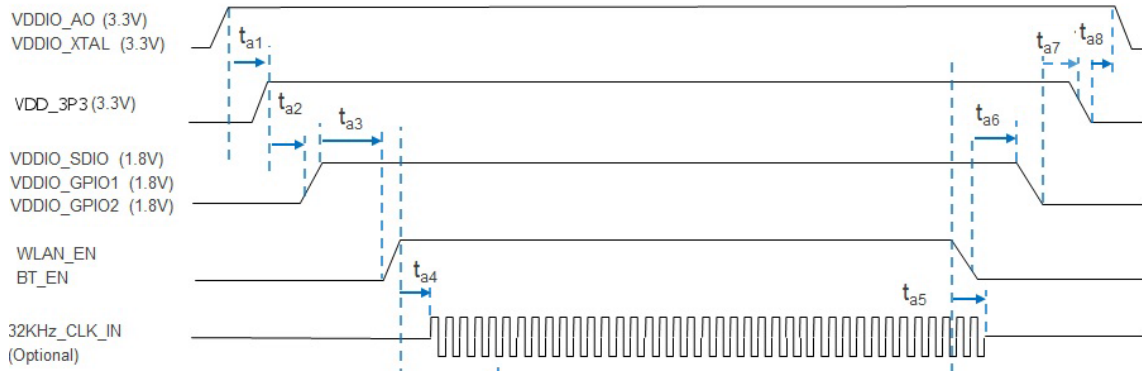

Symbol	Parameter	Min	Max	Units
t_{a1}	No requirement if VDDIO_AO connected to 3.3 V	0	-	μ s
t_{a2}	90% of 3.3 V to 10% of 1.8 V	0	-	μ s
t_{a3}	90% of VDDIO_GPIO to 0.7 V of both WLAN_EN and BT_EN	10	-	μ s
t_{a4}	WLAN_EN valid to LF_CLK_IN input	0	-	μ s
t_{a5}	WLAN_EN de-assert ("low") to LF_CLK_IN de-assert (tristate or low)	0	-	μ s
t_{a6}	Both WLAN_EN = low and BT_EN = low to 90% of 1.8 V	10	-	μ s
t_{a7}	3.3 V always higher than 1.8 V during operation, with power off by removing battery or unplugging AC/DC	0	-	μ s
t_{a8}	VDDIO_AO and VDDIO_XTAL should be connected to 3.3 V power rail	0	-	μ s

12.2. Case 2: 1.8 V power down after 3.3 V

If the battery source cannot be removed from the end user device, this is the recommended power sequence for this application. This sequence allows the software to control the power on/off sequence.

Notes:

1. VDDIO_GPIO voltage should match VIO voltage from the host. In some applications, VDDIO_GPIO may be connected to 3.3 V upon host VIO voltage.
2. Both WLAN_EN and BT_EN of 1PJ are 1.8 V. If host VIO voltage is 1.8 V, it does not need level shifter to interface with host.
3. All host interface signals must stay floating or low before WLAN_EN/BT_EN = "high", and after WLAN_EN/BT_EN = Low.

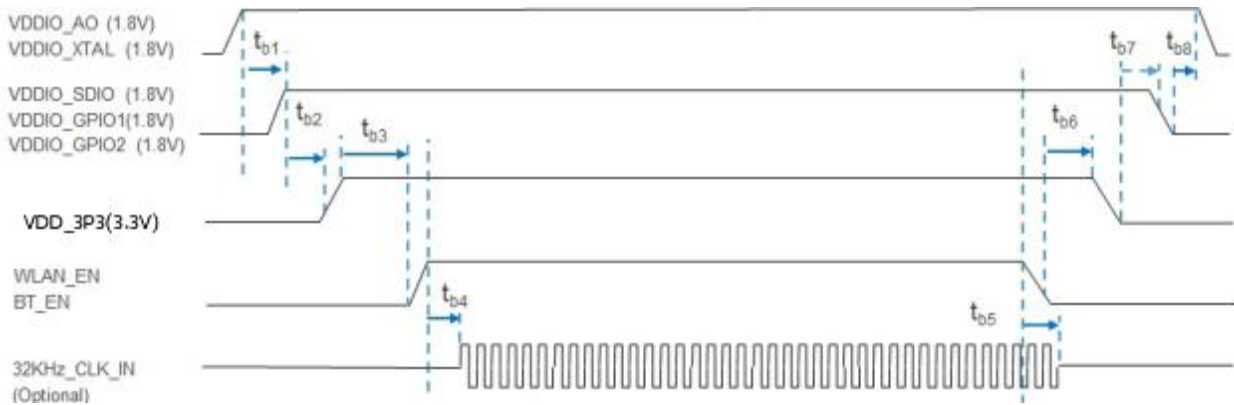

Symbol	Parameter	Min	Max	Units
t _{b1}	No requirement if VDDIO_AO connected to 1.8 V	0	-	μs
t _{b2}	90% of 1.8 V to 10% of 3.3 V	0	-	μs
t _{b3}	90% of 3.3 V to 0.7 V of both WLAN_EN and BT_EN	10	-	μs
t _{b4}	WLAN_EN valid to LF_CLK_IN input	0	-	μs
t _{b5}	WLAN_EN de-assert ("low") to LF_CLK_IN de-assert (tristate or low)	0	-	μs
t _{b6}	Both WLAN_EN = low and BT_EN = low to 90% of 3.3 V	10	-	μs
t _{b7}	10% of 3.3 V to 90% of 1.8 V	0	-	μs
t _{b8}	VDDIO_AO and VDDIO_XTAL should be connected to 1.8 V power rail	0	-	μs

12.3. Case 3: All power rails supplied with 3.3 V

All power pins are connected to 3.3 V only include VDDIO_AO, VDDIO_XTAL, VDDIO_GPIOx.

Notes:

All host signals are either GND or floating before WLAN_EN/BT_EN = "high", and after WLAN_EN/BT_EN = Low.

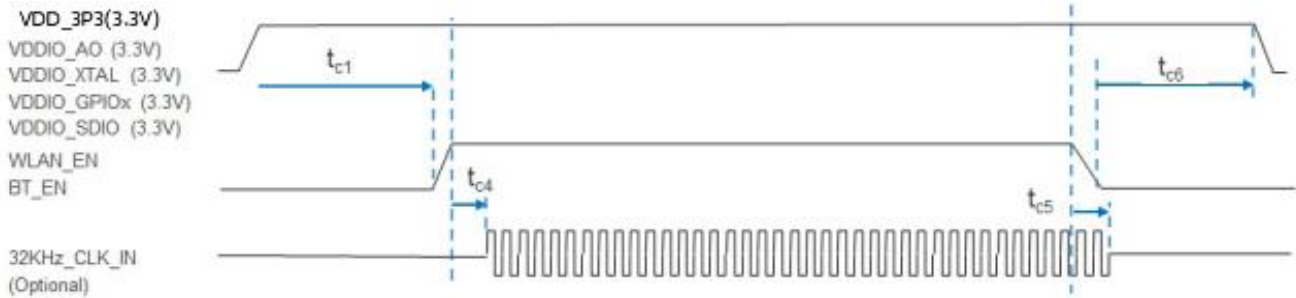

Symbol	Parameter	Min	Max	Units
t _{c1}	90% of 3.3 V to 0.7 V of both WLAN_EN and BT_EN	0	-	µs
t _{c4}	WLAN_EN valid to LF_CLK_IN input	0	-	µs
t _{c5}	WLAN_EN de-assert ("low") to LF_CLK_IN de-assert (tristate or low)	0	-	µs
t _{c6}	Both WLAN_EN = low and BT_EN = low to 90% of 3.3 V	10	-	µs

13. Digital I/O Requirements

Symbol	Parameter	Comments	Minimum	Type	Maximum	Unit
VIH	High-level input voltage		0.7 x VDDIO	-	VDDIO + 0.3	V
VIL	Low-level input voltage		-0.3	-	0.3 x VDDIO	V
VSHYS	Schmitt hysteresis		-	1.8 V IO: 375 3.3 V IO: 645	-	mV
IIL	Input low leakage current	VIN = 0 V Supply = VIO max	-5	-	5	µA
RPULL	Input pull resistor	Up or down	-	1.8 V IO: 120 3.3 V IO: 70	-	kohm
VOH	High-level output voltage		0.9 x VDDIO	-	VDDIO	V
VOL	Low-level output voltage		0	-	0.1 x VDDIO	V
IOH	High-level output current		3	-	-	mA
IOL	Low-level output current		-	-	-11	mA
CIN	Input capacitance		-	-	3	pF

14. INTERFACE TIMING

14.1. Bluetooth UART Timing

14.1.1. UART transmit Timing

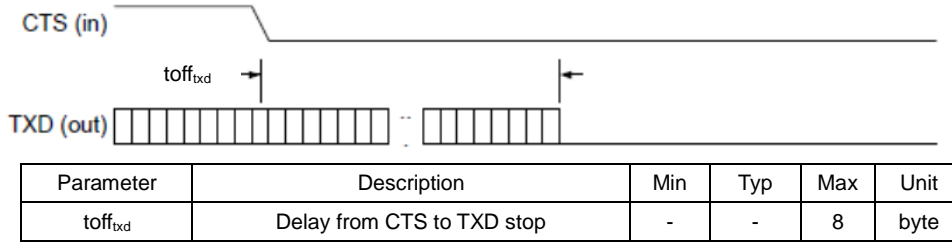

14.1.2. UART Receiver Timing

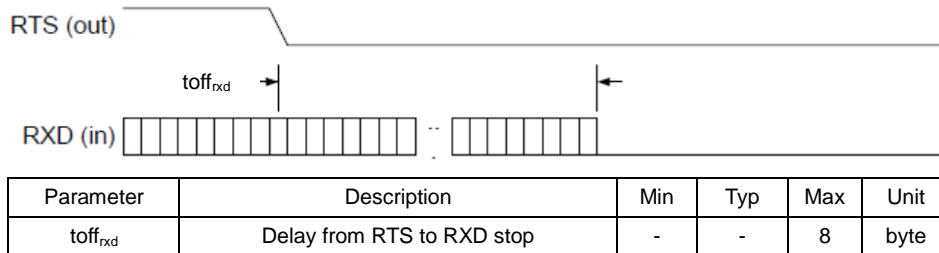

14.2. I²S Timing

	Transmitter				Receiver				Notes
	Lower Limit		Upper Limit		Lower Limit		Upper Limit		
	Min	Max	Min	Max	Min	Max	Min	Max	
Clock Period T	T_{tr}	-	-	-	T_r	-	-	-	a
Master Mode: Clock generated by transmitter or receiver									
HIGH t_{HC}	$0.35T_{tr}$	-	-	-	$0.35T_{tr}$	-	-	-	b
LOW t_{LC}	$0.35T_{tr}$	-	-	-	$0.35T_{tr}$	-	-	-	b
Slave Mode: Clock accepted by transmitter or receiver									
HIGH t_{RC}	-	$0.35T_{tr}$	-	-	-	$0.35T_{tr}$	-	-	c
LOW t_{LC}	-	$0.35T_{tr}$	-	-	-	$0.35T_{tr}$	-	-	c
Rise time t_{RC}	-	-	$0.15T_{tr}$	-	-	-	-	-	d
Transmitter									
Delay t_{dtr}	-	-	-	$0.8T$	-	-	-	-	e
Hold time t_{htr}	0	-	-	-	-	-	-	-	d
Receiver									
Setup time t_{sr}	-	-	-	-	-	$0.2T_r$	-	-	f
Hold time t_{hr}	-	-	-	-	-	0	-	-	f

Notes:

- The system clock period T must be greater than T_{tr} and T_r because both the transmitter and receiver have to be able to handle the data transfer rate.
- At all data rates in master mode, the transmitter or receiver generates a clock signal with a fixed mark/space ratio. For this reason, t_{HC} and t_{LC} are specified with respect to T.
- In slave mode, the transmitter and receiver need a clock signal with minimum HIGH and LOW periods so that they can detect the signal. So long as the minimum periods are greater than $0.35T_r$, any clock that meets the requirements can be used.
- Because the delay (t_{dtr}) and the maximum transmitter speed (defined by T_{tr}) are related, a fast transmitter driven by a slow clock edge can result in t_{dtr} not exceeding t_{RC} which means t_{htr} becomes zero or negative. Therefore, the transmitter has to guarantee that t_{htr} is greater than or equal to zero, so long as the clock rise-time t_{RC} is not more than t_{RCmax} , where t_{RCmax} is not less than $0.15T_{tr}$.
- To allow data to be clocked out on a falling edge, the delay is specified with respect to the rising edge of the clock signal and T, always giving the receiver sufficient setup time.
- The data setup and hold time must not be less than the specified receiver setup and hold time.

14.2.1. I²S Transmitter Timing

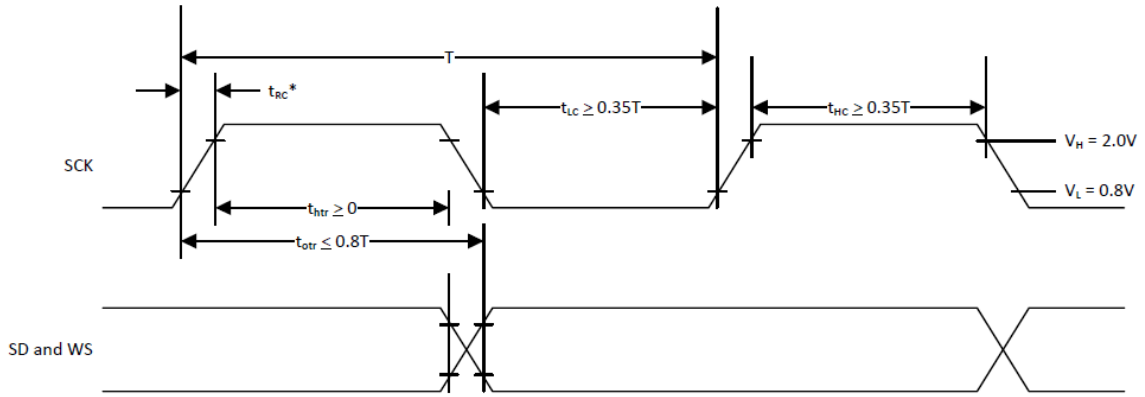

T = Clock period
 T_r = Minimum allowed clock period for transmitter
 $T > T_r$
 * t_{rc} is only relevant for transmitters in slave mode.

14.2.2. I²S Receiver Timing

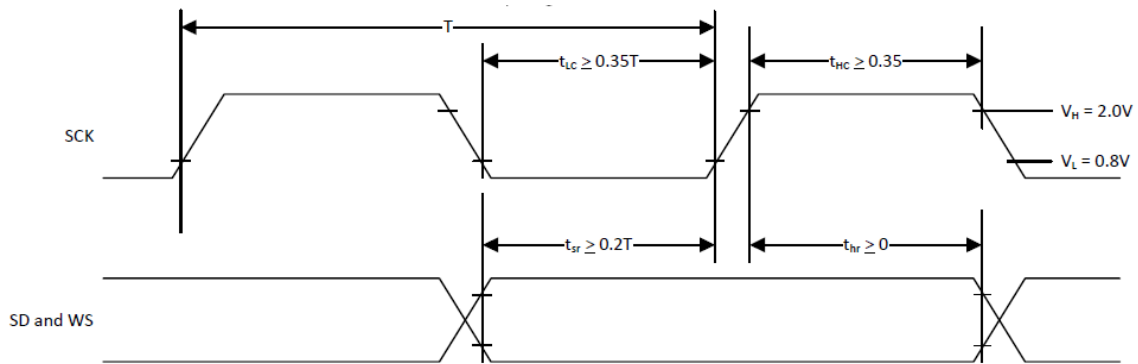

T = Clock period
 T_r = Minimum allowed clock period for transmitter
 $T > T_r$

14.3. SDIO Timing

14.3.1. SDIO Default Mode Timing

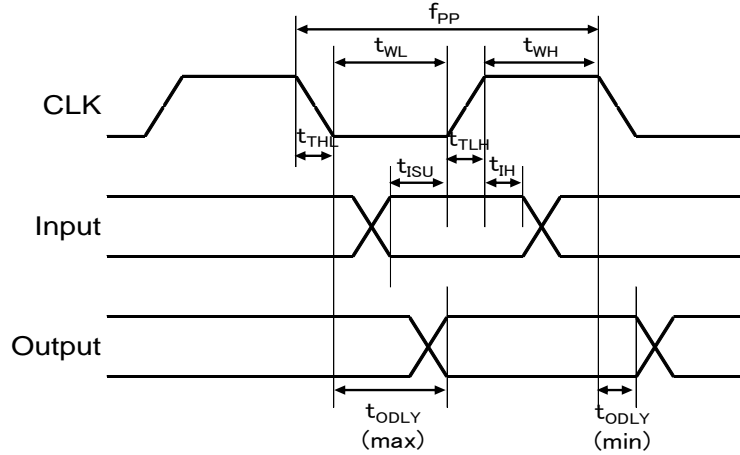

SDIO Bus Timing parameters (default Mode)

Parameter	Symbol	Min	Typ	Max	Unit
SDIO CLK (All values are referred to minimum V_{IH} and maximum V_{IL})					
Frequency-Data Transfer Mode	f_{PP}	0	-	25	MHz
Frequency-Identification Mode	f_{OD}	0 ^a /100	-	400	kHz
Clock Low Time	t_{WL}	10	-	-	ns
Clock High Time	t_{WH}	10	-	-	ns
Clock Rise Time	t_{TLH}	-	-	10	ns
Clock low Time	t_{THL}	-	-	10	ns
Inputs: CMD, DAT (referenced to CLK)					
Input Setup Time	t_{ISU}	5	-	-	ns
Input Hold Time	t_{IH}	5	-	-	ns
Outputs: CMD, DAT (referenced to CLK)					
Output Delay time-Data Transfer Mode	t_{ODLY}	0	-	14	ns
Output Delay time-Identification Mode	t_{ODLY}	0	-	50	ns

a. 0 Hz means to stop the clock. The given minimum frequency range is for cases where continuous clock is required.

14.3.2. SDIO High-Speed Mode Timing

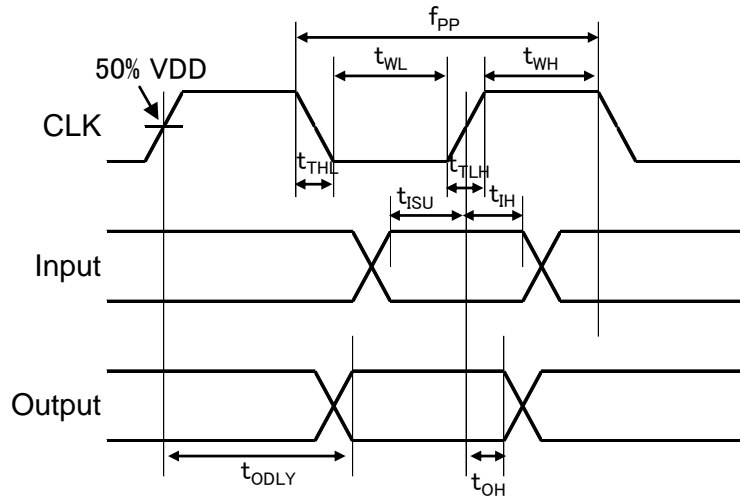

SDIO Bus Timing parameters (High-Speed Mode)

Parameter	Symbol	Min	Typ	Max	Unit
SDIO CLK (All values are referred to minimum VIH and maximum VIL)					
Frequency-Data Transfer Mode	f_{PP}	0	-	50	MHz
Clock Low Time	t_{WL}	7	-	-	ns
Clock High Time	t_{WH}	7	-	-	ns
Clock Rise Time	t_{TLH}	-	-	3	ns
Clock low Time	t_{THL}	-	-	3	ns
Inputs: CMD, DAT (referenced to CLK)					
Input Setup Time	t_{ISU}	6	-	-	ns
Input Hold Time	t_{IH}	2	-	-	ns
Outputs: CMD, DAT (referenced to CLK)					
Output Delay time-Data Transfer Mode	t_{ODLY}	-	-	14	ns
Output Hold time	t_{OH}	2.5	-	-	ns
Total System Capacitance (each line)	C_L	-	-	40	pF

14.3.1. SDIO UHS mode Timing

In UHS mode the supported features are:

1. Embedded SDIO

The chip is only designed for embedded system; that is, it should be mounted on the PCB with host system and not support plug & play.

2. Fixed voltage supply (VDDIO_SDIO 1.8 V)

There is no on-chip LDO to do voltage switch when it receives CMD11 (voltage switch command). In other words, the VDDIO_SDIO power supply is provided from host and should keep constant. Note, though, it does not support voltage switch, it does follow the timing flow of CMD11, with the exception of no voltage change, so there is no effect to SW code.

3. Support for 8-bit mode

The 8-bit mode dedicated to embedded system is supported with the maximum frequency of 50 MHz

a). Clock signal timing

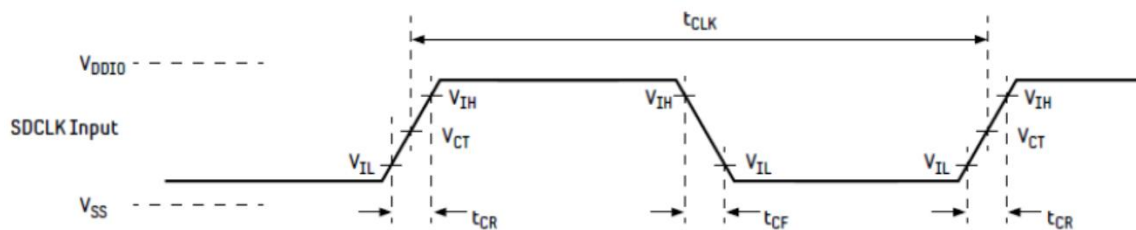

Symbol	Min	Max	Unit	Remark
t_{CLK}	4.8	-	ns	208MHz (max.) between rising edge, $V_{CT}=0.975V$
t_{CR}, t_{CF}	-	$0.2 \cdot t_{CLK}$	ns	$t_{CR}, t_{CF} < 0.96ns$ (max.) at 208MHz, $C=10 pF$
Clock duty	30	70	%	

b). Input timing

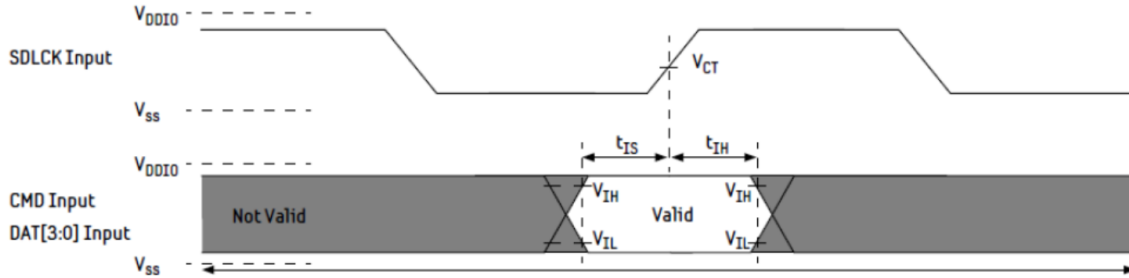

Symbol	Min	Max	Unit	SDR104 mode
t_{IS}	1.4	-	ns	$C = 10 pF, V_{CT}=0.975V$
t_{IH}	0.8	-	ns	$C=10 pF, V_{CT}=0.975V$
Symbol	Min	Max	Unit	SDR12, SDR25 and SDR50 modes
t_{IS}	3	-	ns	$C = 10 pF, V_{CT}=0.975V$
t_{IH}	0.8	-	ns	$C=10 pF, V_{CT}=0.975V$

c). Output timing (SDR12/SDR25/SDR50)

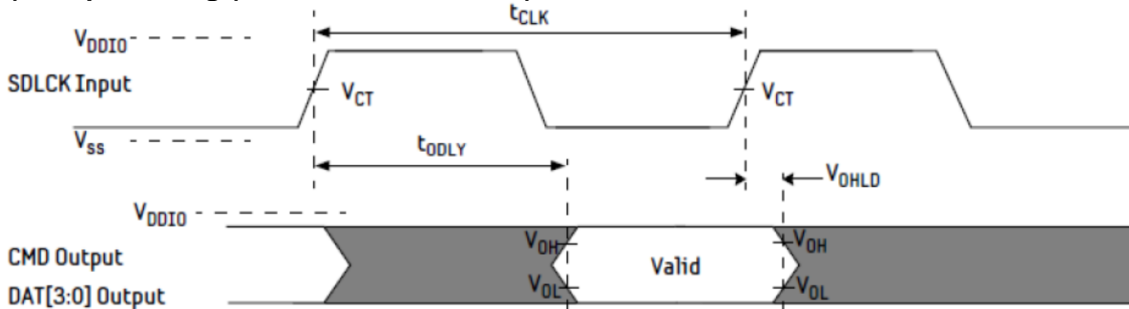

Symbol	Min	Max	Unit	Remark
t_{ODLY}	-	7.5	ns	$T_{CLK}=10ns, CL=30 pF$, driver B for SDR50
t_{TODLY}	-	14	ns	$T_{CLK}=20ns, CL=40 pF$, driver B for SDR25,12
t_{OH}	1.5	-	ns	Hold time at the t_{ODLY} , $CL=15 pF$

d). Output timing (SDR104)

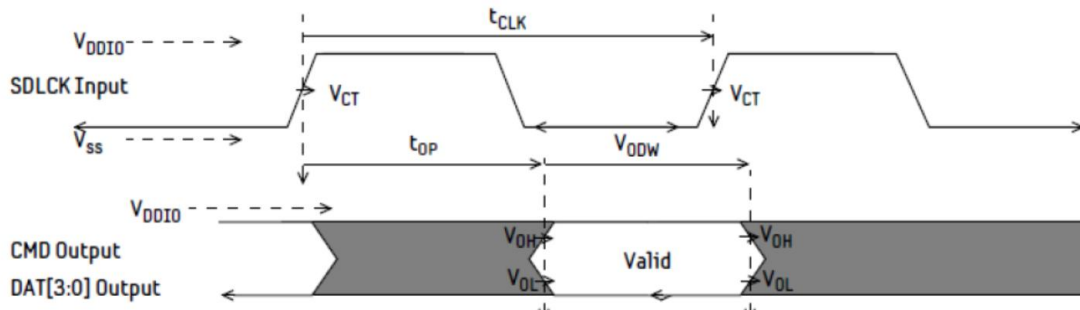

Symbol	Min	Max	Unit	Remark
t_{OP}	0	2	UI	Output phase
Delta t_{OP}	-350	1550	ps	Delay variation due to temperature change after tuning
t_{ODW}	0.6	-	UI	$t_{ODW}=2.88ns$ at 208 MHz.

15. DC / RF Characteristics

15.1. DC/RF Characteristics for IEEE802.11b - 2.4GHz

Specification	IEEE802.11b
Mode	DSSS / CCK
Frequency	2412 to 2472 MHz
Data rate	1, 2, 5.5, 11Mbps

Conditions : 25deg.C,
 VDD_3P3,VDDIO_SDIO,VDDIO_GPIO1,VDDIO_GPIO2,VDDIO_XTAL,VDDIO_AO=3.3V
 Output power setting=19 dBm, 11Mbps mode unless otherwise specified.

Items	Contents			
	min.	typ.	max.	unit
- DC Characteristics -				
1. DC current				
1) Tx mode (1024byte, 20usec interval) *4) *5)	-	330	-	mA
2) Rx mode	-	60	-	mA
- Tx Characteristics -				
	min.	typ.	max.	Unit
2. Output Power	-	19	-	dBm
3. Spectrum Mask margin				
1) 1st side lobes(-30dBr)	0	-	-	dB
2) 2nd side lobes(-50dBr)	0	-	-	dB
4. Power-on and Power-down ramp	-		2.0	Msec
5. RF Carrier Suppression	15	-	-	dB
6. Modulation Accuracy (EVM)	-	-	35	%
7. Frequency tolerance	-20	-	20	Ppm
8. Out band Spurious Emissions				
1) 30-1000MHz	-	-	-36	dBm
2) 1000-12750MHz	-	-	-30	dBm
3) 1800-1900MHz			-47	dBm
4) 5150-5300MHz	-	-	-47	dBm
- Rx Characteristics -				
	min.	typ.	max.	Unit
9. Minimum Input Level Sensitivity	-	-89	-76	dBm
10. Maximum Input Level (PER ≤ 8%)	-10	-	-	dBm
11. Adjacent Channel Rejection (FER ≤ 8%)	35	-	-	dB

*4): Defined when output power setting is 19 dBm at Murata module antenna pad

*5): Data rate is 1Mbps

15.2. DC/RF Characteristics for IEEE802.11g - 2.4GHz

Specification	IEEE802.11g
Mode	OFDM
Frequency	2412 to 2472 MHz
Data rate	6, 9, 12, 18, 24, 36, 48, 54Mbps

Conditions : 25deg.C,
VDD_3P3,VDDIO_SDIO,VDDIO_GPIO1,VDDIO_GPIO2,VDDIO_XTAL,VDDIO_AO=3.3V
Output power setting=17 dBm, 54Mbps mode unless otherwise specified.

Items	Contents			
	min.	typ.	max.	Unit
- DC Characteristics -				
1. DC current				
1) Tx mode (1024byte, 20usec interval *6) *7)	-	310	-	mA
2) Rx mode	-	60	-	mA
- Tx Characteristics -				
	min.	typ.	max.	Unit
2. Output Power	-	17	-	dBm
3. Spectrum Mask margin				
1) 9MHz to 11MHz (0~ -20dBr)	0	-	-	dB
2) 11MHz to 20MHz (-20~ -28dBr)	0	-	-	dB
3) 20MHz to 30MHz (-28~ -40dBr)	0	-	-	dB
4) 30MHz to 33MHz (-40dBr)	0	-	-	dB
4. Constellation Error (EVM)	-	-	-25	dB
5. Frequency tolerance	-20	-	20	Ppm
6. Out band Spurious Emissions				
1) 30-1000MHz	-	-	-36	dBm
2) 1000-12750MHz	-	-	-30	dBm
3) 1800-1900MHz	-	-	-47	dBm
4) 5150-5300MHz	-	-	-47	dBm
- Rx Characteristics -				
	min.	typ.	max.	Unit
7. Minimum Input Level Sensitivity	-	-74	-65	dBm
8. Maximum Input Level (PER ≤ 10%)	-20	-	-	dBm
9. Adjacent Channel Rejection (PER ≤ 10%)	-1	-	-	dB

*6): Defined when output power setting is 18dBm at Murata module antenna pad

*7): Data rate is 6Mbps

15.3. DC/RF Characteristics for IEEE802.11n – 2.4GHz

Specification	IEEE802.11n
Mode	OFDM
Frequency	2412 to 2472 MHz
Data rate	MCS0-MCS7

Conditions : 25deg.C,
VDD_3P3,VDDIO_SDIO,VDDIO_GPIO1,VDDIO_GPIO2,VDDIO_XTAL,VDDIO_AO=3.3V
Output power setting=16 dBm, BW=20MHz, MCS7 unless otherwise specified.

- DC Characteristics -	min.	typ.	max.	Unit
1. DC current				
1) Tx mode (1024byte, 20usec interval *8)*9)	-	310	-	mA
2) Rx mode	-	60	-	mA
- Tx Characteristics -	min.	typ.	max.	Unit
2. Output Power	-	16	-	dBm
3. Spectrum Mask				
1) 9MHz to 11MHz (0 ~ -20dBr)	0	-	-	dB
2) 11MHz to 20MHz (-20 ~ -28dBr)	0	-	-	dB
3) 20MHz to 30MHz (-28 ~ -45dBr)	0	-	-	dB
4) 30MHz to 33MHz (-45dBr)	0	-	-	dB
4. Constellation Error (EVM)	-	-	-27	dB
5. Frequency tolerance	-20	-	20	Ppm
6. Out band Spurious Emissions				
1) 30-1000MHz	-	-	-36	dBm
2) 1000-12750MHz	-	-	-30	dBm
3) 1800-1900MHz	-	-	-47	dBm
4) 5150-5300MHz	-	-	-47	dBm
- Rx Characteristics -	min.	typ.	max.	Unit
7. Minimum Input Level Sensitivity	-	-71	-64	dBm
8. Adjacent Channel Rejection (PER ≤ 10%)	-2	-	-	dB

*8): Defined when output power setting is 18 dBm at Murata module antenna pad

*9): Data rate is MCS0

15.4. DC/RF Characteristics for IEEE802.11a - 5GHz

Specification	IEEE802.11a
Mode	OFDM
Frequency	5180 to 5825MHz
Data rate	6, 9, 12, 18, 24, 36, 48, 54Mbps

Conditions : 25deg.C,
VDD_3P3,VDDIO_SDIO,VDDIO_GPIO1,VDDIO_GPIO2,VDDIO_XTAL,VDDIO_AO=3.3V
Output power setting= 11 dBm, 54Mbps unless otherwise specified.

- DC Characteristics -	min.	typ.	max.	Unit
1. DC current				
1) Tx mode (1024byte, 20usec interval *8)*9)	-	420	-	mA
2) Rx mode	-	80	-	mA
- Tx Characteristics -	min.	typ.	max.	Unit
2. Output Power	-	11	-	dBm
3. Spectrum Mask				
1) 9MHz to 11MHz (0 ~ -20dBr)	0	-	-	dB
2) 11MHz to 20MHz (-20 ~ -28dBr)	0	-	-	dB
3) 20MHz to 30MHz (-28 ~ -45dBr)	0	-	-	dB
4) 30MHz to 33MHz (-45dBr)	0	-	-	dB
4. Constellation Error (EVM)	-	-	-25	dB
5. Frequency tolerance	-20	-	20	Ppm
6. Out band Spurious Emissions				
1) 30-1000MHz	-	-	-36	dBm
2) 1000-12750MHz	-	-	-30	dBm
3) 1800-1900MHz	-	-	-47	dBm
4) 5150-5300MHz	-	-	-47	dBm
- Rx Characteristics -	min.	typ.	max.	Unit
7. Minimum Input Level Sensitivity	-	-71	-65	dBm
8. Adjacent Channel Rejection (PER ≤ 10%)	-1	-	-	dB

*8): Defined when output power setting is 14 dBm at Murata module antenna pad

*9): Data rate is 6Mbps

15.5. DC/RF Characteristics for IEEE802.11n - 5GHz

Specification	IEEE802.11n
Mode	OFDM
Frequency	5180 to 5825MHz
Data rate	MCS0-MCS7

Conditions : 25deg.C,
VDD_3P3,VDDIO_SDIO,VDDIO_GPIO1,VDDIO_GPIO2,VDDIO_XTAL,VDDIO_AO=3.3V
Output power setting= 10 dBm, BW=20MHz ,MCS7 unless otherwise specified.

- DC Characteristics -	min.	typ.	max.	Unit
1. DC current				
1) Tx mode (1024byte, 20usec interval *8)*9)	-	420	-	mA
2) Rx mode	-	80	-	mA
- Tx Characteristics -	min.	typ.	max.	Unit
2. Output Power	-	10	-	dBm
3. Spectrum Mask				
1) 9MHz to 11MHz (0 ~ -20dBr)	0	-	-	dB
2) 11MHz to 20MHz (-20 ~ -28dBr)	0	-	-	dB
3) 20MHz to 30MHz (-28 ~ -45dBr)	0	-	-	dB
4) 30MHz to 33MHz (-45dBr)	0	-	-	dB
4. Constellation Error (EVM)	-	-	-27	dB
5. Frequency tolerance	-20	-	20	Ppm
6. Out band Spurious Emissions				
1) 30-1000MHz	-	-	-36	dBm
2) 1000-12750MHz	-	-	-30	dBm
3) 1800-1900MHz	-	-	-47	dBm
4) 5150-5300MHz	-	-	-47	dBm
- Rx Characteristics -	min.	typ.	max.	Unit
7. Minimum Input Level Sensitivity	-	-69	-64	dBm
8. Adjacent Channel Rejection (PER ≤ 10%)	-2	-	-	dB

*8): Defined when output power setting is 14 dBm at Murata module antenna pad

*9): Data rate is MCS0

15.6. DC/RF Characteristics for IEEE802.11ac - 5GHz

Specification	IEEE802.11ac
Mode	OFDM
Frequency	5210 to 5775MHz
Data rate	MCS0-MCS9

Conditions : 25deg.C,
VDD_3P3,VDDIO_SDIO,VDDIO_GPIO1,VDDIO_GPIO2,VDDIO_XTAL,VDDIO_AO=3.3V
Output power setting= 8 dBm, BW=80MHz ,MCS9 unless otherwise specified.

- DC Characteristics -	min.	typ.	max.	Unit
1. DC current				
1) Tx mode (1024byte, 20usec interval *8)*9)	-	370	-	mA
2) Rx mode	-	90	-	mA
- Tx Characteristics -	min.	typ.	max.	Unit
2. Output Power *10)	-	8	-	dBm
3. Spectrum Mask				
1) 9MHz to 11MHz (0 ~ -20dBr)	0	-	-	dB
2) 11MHz to 20MHz (-20 ~ -28dBr)	0	-	-	dB
3) 20MHz to 30MHz (-28 ~ -45dBr)	0	-	-	dB
4) 30MHz to 33MHz (-45dBr)	0	-	-	dB
4. Constellation Error (EVM)	-	-	-32	dB
5. Frequency tolerance	-20	-	20	Ppm
6. Out band Spurious Emissions				
1) 30-1000MHz	-	-	-36	dBm
2) 1000-12750MHz	-	-	-30	dBm
3) 1800-1900MHz	-	-	-47	dBm
4) 5150-5300MHz	-	-	-47	dBm
- Rx Characteristics -	min.	typ.	max.	Unit
7. Minimum Input Level Sensitivity	-	-59	-51	dBm
8. Adjacent Channel Rejection (PER ≤ 10%)	-9	-	-	dB

*8): Defined when output power setting is 12dBm at Murata module antenna pad

*9): Data rate is MCS0

*10): Target output power for MCS9 VHT=40 at 5190, 5230, 5270 and 5310MHz is 7dBm.

15.7. DC/RF Characteristics for Bluetooth

Conditions : 25deg.C,

VDD_3P3,VDDIO_SDIO,VDDIO_GPIO1,VDDIO_GPIO2,VDDIO_XTAL,VDDIO_AO=3.3V

Items	Contents			
Bluetooth specification (power class)	Version 5.0 (Class 1)			
Channel frequency (spacing)	2402 to 2480 MHz (1MHz)			
Current Consumption	Min.	Typ.	Max.	unit
(a) Tx=DH5	-	55	-	mA
(b) Tx=2DH5	-	50	-	mA
(c) Tx=3DH5	-	50	-	mA
(d) Rx=DH5	-	22	-	mA
(e) Rx=2DH5	-	22	-	mA
(f) Rx=3DH5	-	22	-	mA
Transmitter	Min.	Typ.	Max.	Unit
Output Power@DH5			8	dBm
Frequency range	2402	-	2480	MHz
20dB bandwidth	-	950	1000	MHz
Adjacent Channel Power ^{*1}				
(a) [M-N] =2	-	-	-20	dBm
(b) [M-N] ≥3	-	-	-40	dBm
Modulation characteristics				
(a) Modulation Δf1avg	140	-	175	kHz
(b) Modulation Δf2max	115		-	kHz
(c) Modulation Δf2avg / Δf1avg	0.8	-	-	
Carrier Frequency Drift				
(a) 1slot	-25	-	+25	kHz
(b) 3slot / 5slot	-40	-	+40	kHz
(c) Maximum drift rate		-	20	kHz/50us
EDR Relative Power	-4	-	+1	dB
EDR Carrier Frequency Stability and Modulation Accuracy				
(a) ωi	-75	-	+75	kHz
(b) ωi+ωo	-75	-	+75	kHz
(c) ωo	-10	-	+10	kHz
(d) RMS DEVM (DQPSK)	-	-	20	%
(e) Peak DEVM (DQPSK)	-	-	35	%
(f) 99% DEVM (DQPSK)	-	-	30	%
(g) RMS DEVM (8DPSK)	-	-	13	%
(h) Peak DEVM (8DPSK)	-	-	25	%
(i) 99% DEVM (8DPSK)	-	-	20	%
Spurious Emissions				
(a) 10MHz ≤ f < 2387MHz	-	-	-36	dBm
(b) 2387MHz ≤ f < 2400MHz	-	-	-30	dBm
(c) 2483.5MHz < f ≤ 2496.5MHz			-47	dBm
(d) 2496.5MHz < f ≤ 8GHz	-	-	-47	dBm
Receiver	Min.	Typ.	Max.	unit
BDR Sensitivity (BER≤0.1%)	-	-92	-80	dBm
EDR Sensitivity (BER≤0.007%)@8DPSK	-	-87	-77	dBm
C/I Performance (BER≤0.1%) ^{*2}				
(a) co-channel	-	-	11	dB
(b) 1MHz	-	-	0	dB
(c) 2MHz	-	-	-30	dB
(d) 3MHz	-	-	-40	dB
Maximum Input Level (BER≤0.1%)	-20	-	-	dBm

*1: Up to three spurious responses within Bluetooth limits are allowed.

*2: Up to five spurious responses within Bluetooth limits are allowed.

15.8. DC/RF Characteristics for Bluetooth (LE)

Conditions : 25deg.C,

VDD_3P3,VDDIO_SDIO,VDDIO_GPIO1,VDDIO_GPIO2,VDDIO_XTAL,VDDIO_AO=3.3V

Items	Contents			
Bluetooth specification (power class)	Version 5.0 (LE)			
Channel frequency (spacing)	2402 to 2480 MHz (2MHz)			
Number of RF Channel	40			
Item / Condition	Min.	Typ.	Max.	Unit
Center Frequency	2402	-	2480	MHz
Channel Spacing	-	2	-	MHz
Number of RF channel	-	40	-	-
Output power			8	dBm
Modulation Characteristics				
1) $\Delta f_{1_{avg}}$	225	-	275	kHz
2) $\Delta f_{2_{max}}$ (at 99.9%)	185	-	-	kHz
3) $\Delta f_{2_{avg}} / \Delta f_{1_{avg}}$	0.8	-	-	-
Carrier frequency offset and drift				
1) Frequency offset	-	-	150	kHz
2) Frequency drift	-	-	50	kHz
3) Drift rate	-	-	20	kHz
Receiver sensitivity (PER < 30.8%)	-	-96	-70	dBm
Maximum input signal level (PER < 30.8%)	-10	-	-	dBm
PER Report Integrity (-30dBm input)	50	-	65.4	%

16. LAND PATTERN (TOP VIEW)

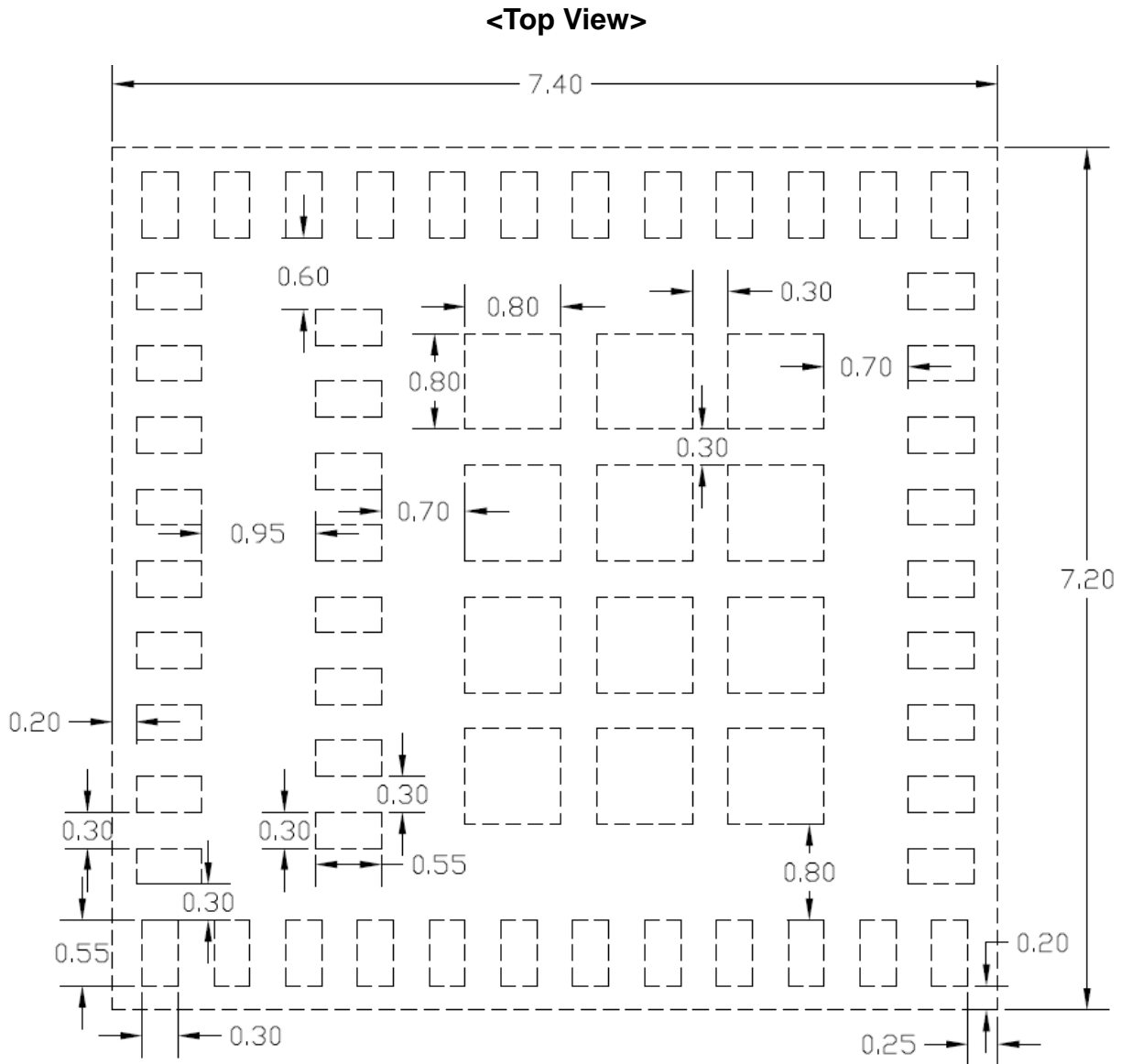

*****Stencil design:**

For 0.3x0.55mm electrodes, stencil pad is 0.24mm*0.44mm and should put in the center of the each conductor.

For 0.8x0.8mm electrodes, stencil pad is 0.66mm*0.66mm and should put in the center of the each conductor.

***This is based on Murata's condition using the thickness of the stencil 100 um.
So this is just the recommendation and needs to modify based on your condition.

17. REFERENCE CIRCUIT

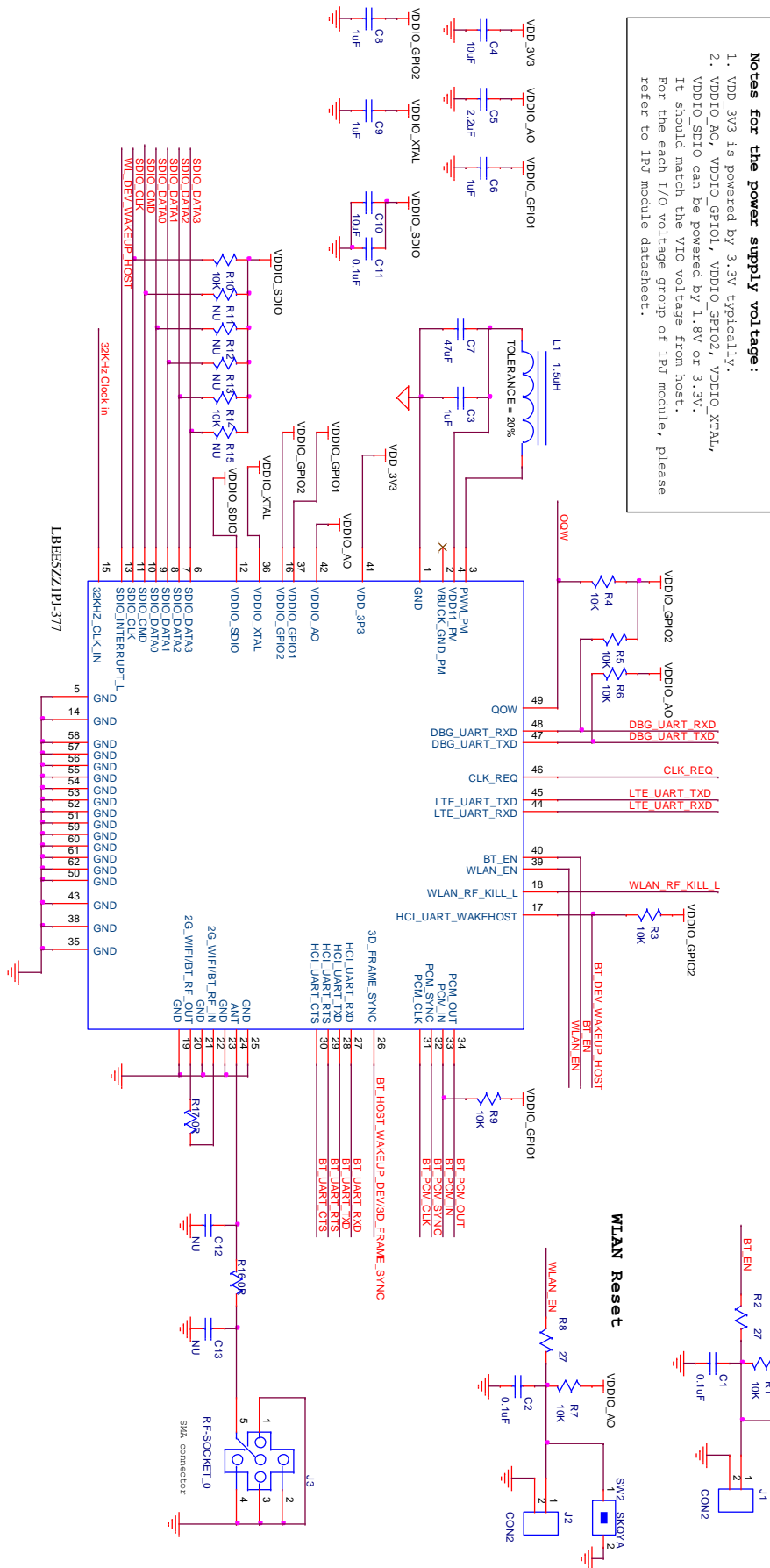

18. TAPE AND REEL PACKING

(1) Dimensions of Tape (Plastic tape)

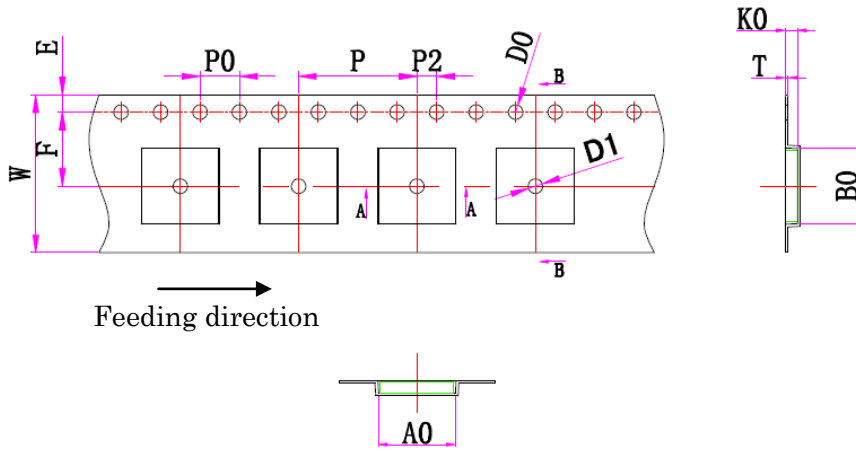

Unit: mm

W	16+/-0.2	P2	2+/-0.1
F	7.5+/-0.1	A0	7.8+/-0.1
T	0.3+/-0.05	B0	7.6+/-0.1
E	1.75+/-0.1	K0	1.25+/-0.1
P	12+/-0.1	D0	1.5+0.1/-0
P0	4+/-0.1	D1	1.5+/-0.1

(2) Dimensions of Reel

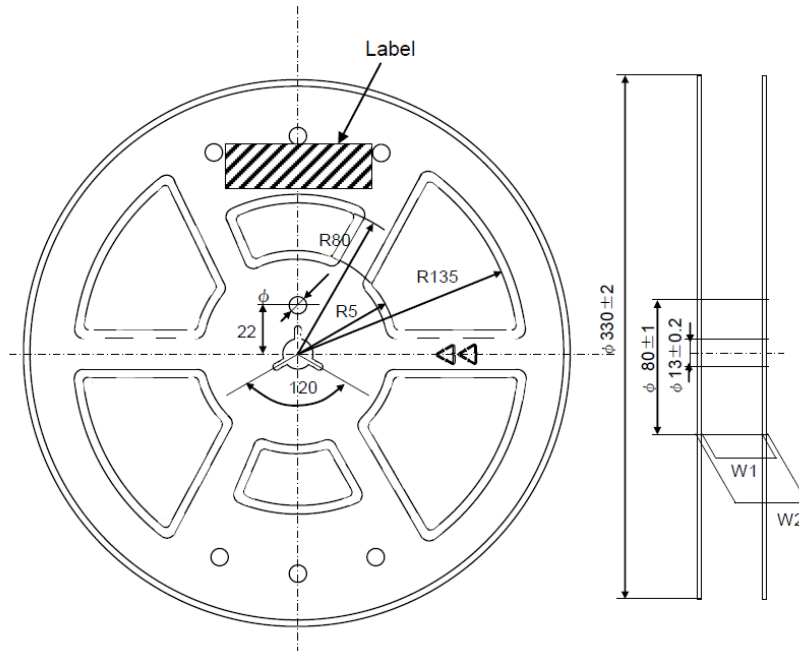

Unit: mm

W1	17.5 +/-1.0
W2	21.5 +/-1.0

(3) Taping Diagrams

- [1] Feeding Hole : As specified in (1)
- [2] Hole for chip : As specified in (1)
- [3] Cover tape : 62 um in thickness
- [4] Base tape : As specified in (1)

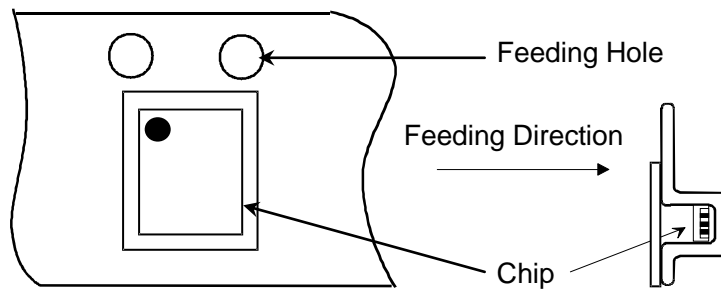
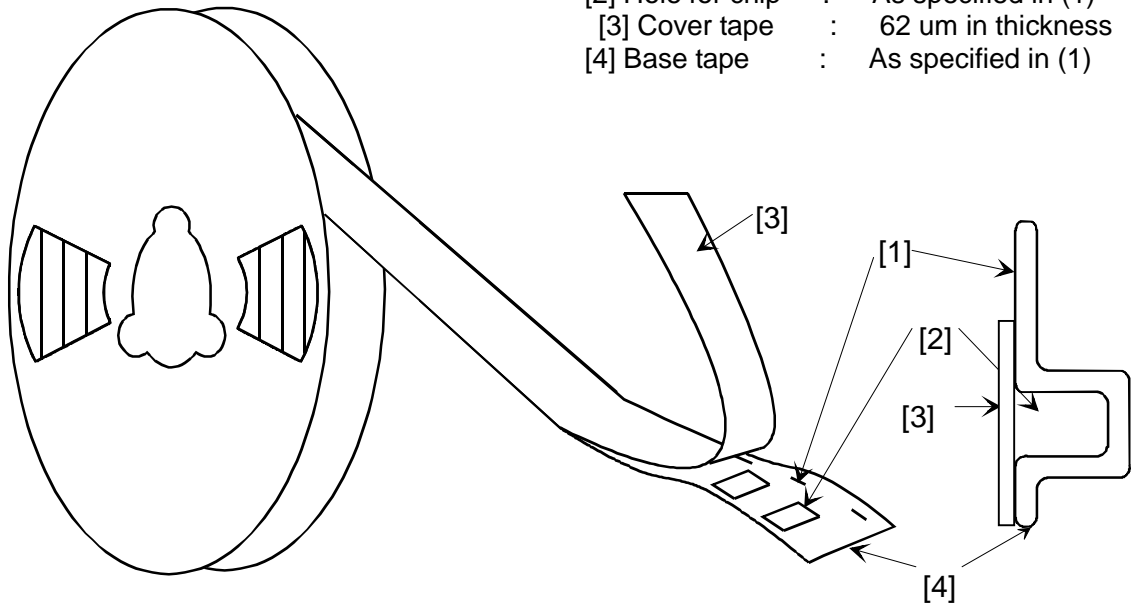

(4) Leader and Tail tape

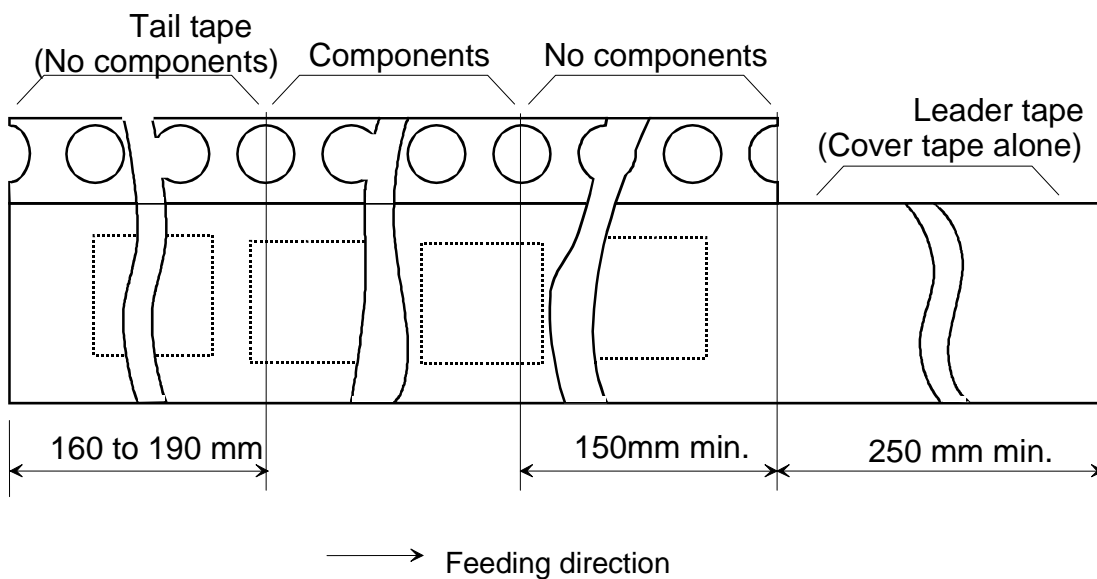

- The tape for chips are wound clockwise, the feeding holes to the right side as the tape is pulled toward the user.
- The cover tape and base tape are not adhered at no components area for 250 mm min.
- Tear off strength against pulling of cover tape: 5 N min.
- Packaging unit: 1000 pcs/ reel
- Material: Base tape: Plastic
Reel : Plastic
Cover tape, cavity tape and reel are made the anti-static processing.
- Peeling of force: 1.1 N max. in the direction of peeling as shown below.

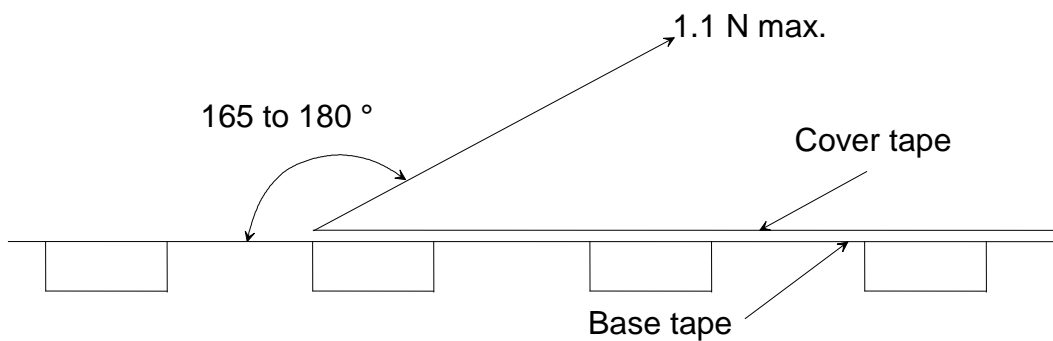

- PACKAGE (Humidity proof packing)

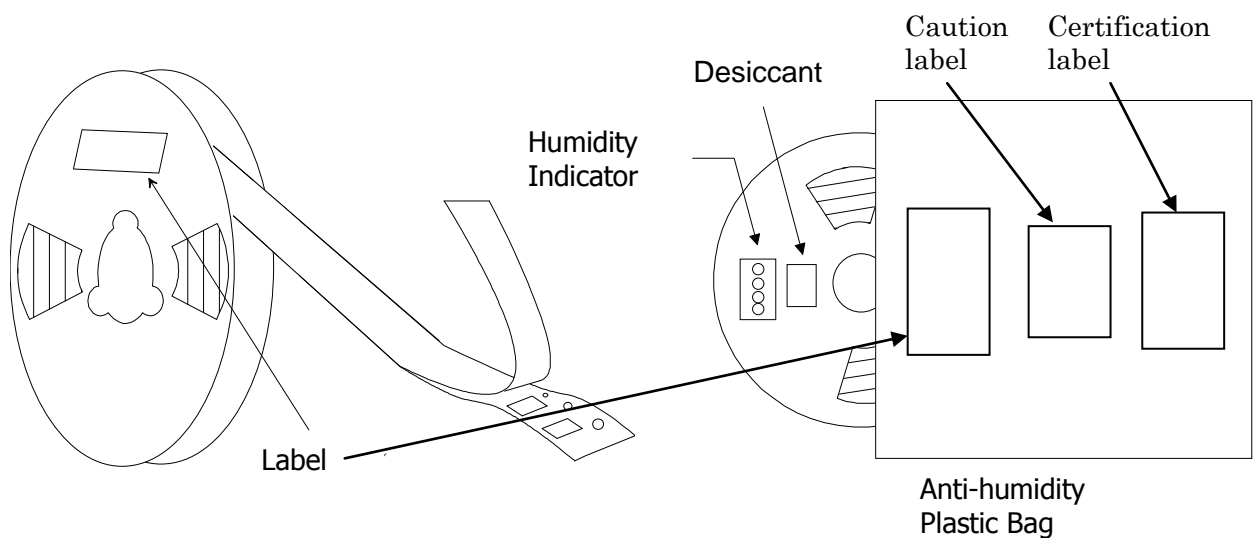

Tape and reel must be sealed with the anti-humidity plastic bag. The bag contains the desiccant and the humidity indicator.

- Box

Box for plastic bag: 90 x 350 x 350 mm

Carton box: 390 x 380 x 380 mm

5 boxes for plastic bag are stored to a carton box as below.

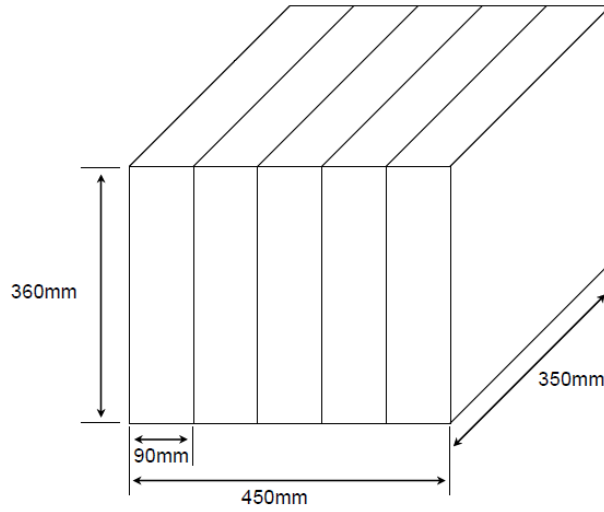

- Label

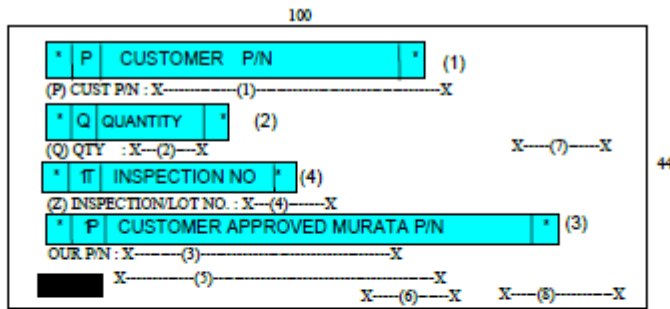

1	Customer P/N	得意先品番
2	Quantity	数量
3	Customer Approved Murata P/N	村田品番
4	Serial No	検印/LOT No.
5	Opposite P/N to Customer Approved Murata P/N	村田品番(逆品名)
6	Packing Code	包装コード
7	Murata Standard ROHS discrimination	ROHS
8	Country of origin	原産地表示

19. NOTICE**19.1. Storage Conditions:**

Please use this product within 6month after receipt.

- The product shall be stored without opening the packing under the ambient temperature from 5 to 35deg.C and humidity from 20 to 70%RH.

(Packing materials, in particular, may be deformed at the temperature over 40deg.C.)

- The product left more than 6months after reception, it needs to be confirmed the solderbility before used.

- The product shall be stored in non corrosive gas (Cl₂, NH₃, SO₂, No_x, etc.).

- Any excess mechanical shock including, but not limited to, sticking the packing materials by sharp object and dropping the product, shall not be applied in order not to damage the packing materials.

This product is applicable to MSL3 (Based on JEDEC Standard J-STD-020)

- After the packing opened, the product shall be stored at $\leq 30\text{deg.C}$ / $\leq 60\%RH$ and the product shall be used within 168hours.

- When the color of the indicator in the packing changed, the product shall be baked before soldering.

Baking condition: 125+5/-0deg.C, 24hours, 1time

The products shall be baked on the heat-resistant tray because the material (Base Tape, Reel Tape and Cover Tape) are not heat-resistant.

19.2. Handling Conditions:

Be careful in handling or transporting products because excessive stress or mechanical shock may break products.

Handle with care if products may have cracks or damages on their terminals, the characteristics of products may change. Do not touch products with bear hands that may result in poor solder ability and destroy by static electrical charge.

19.3. Standard PCB Design (Land Pattern and Dimensions):

All the ground terminals should be connected to the ground patterns. Furthermore, the ground pattern should be provided between IN and OUT terminals. Please refer to the specifications for the standard land dimensions.

The recommended land pattern and dimensions is as Murata's standard. The characteristics of products may vary depending on the pattern drawing method, grounding method, land dimensions, land forming method of the NC terminals and the PCB material and thickness. Therefore, be sure to verify the characteristics in the actual set. When using non-standard lands, contact Murata beforehand.

19.4. Notice for Chip Placer:

When placing products on the PCB, products may be stressed and broken by uneven forces from a worn-out chucking locating claw or a suction nozzle. To prevent products from damages, be sure to follow the specifications for the maintenance of the chip placer being used. For the positioning of products on the PCB, be aware that mechanical chucking may damage products.

19.5. Soldering Conditions:

The recommendation conditions of soldering are as in the following figure.

When products are immersed in solvent after mounting, pay special attention to maintain the temperature difference within 100 °C. Soldering must be carried out by the above mentioned conditions to prevent products from damage. Set up the highest temperature of reflow within 260 °C. Contact Murata before use if concerning other soldering conditions.

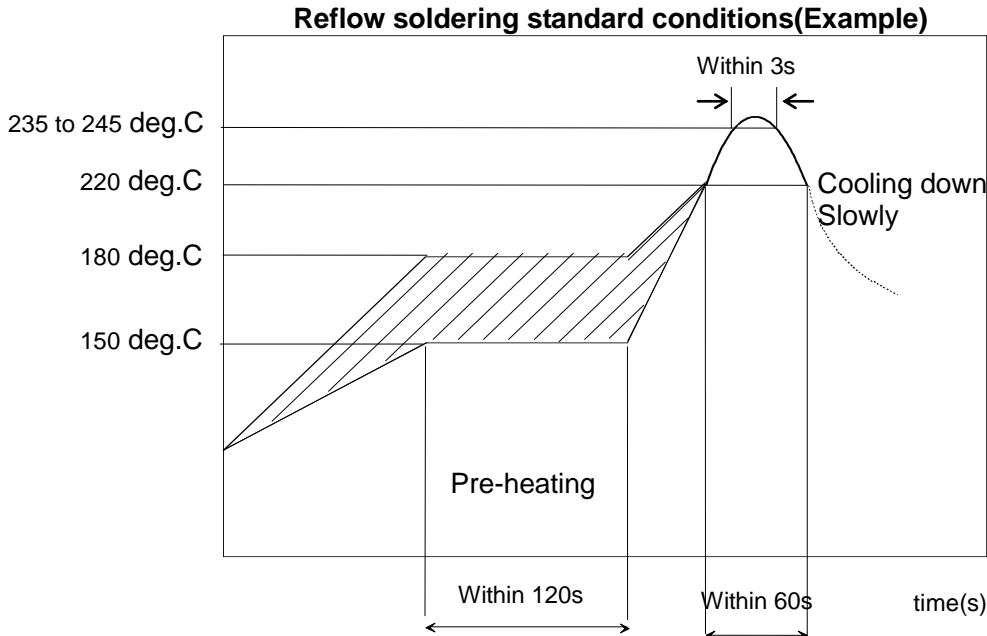

Please use the reflow within 2 times.

Use rosin type flux or weakly active flux with a chlorine content of 0.2 wt % or less.

19.6. Cleaning:

Since this Product is Moisture Sensitive, any cleaning is not permitted.

19.7. Operational Environment Conditions:

Products are designed to work for electronic products under normal environmental conditions (ambient temperature, humidity and pressure). Therefore, products have no problems to be used under the similar conditions to the above-mentioned. However, if products are used under the following circumstances, it may damage products and leakage of electricity and abnormal temperature may occur.

- In an atmosphere containing corrosive gas (Cl₂, NH₃, SO_x, NO_x etc.).
- In an atmosphere containing combustible and volatile gases.
- Dusty place.
- Direct sunlight place.
- Water splashing place.
- Humid place where water condenses.
- Freezing place.

If there are possibilities for products to be used under the preceding clause, consult with Murata before actual use.

As it might be a cause of degradation or destruction to apply static electricity to products, do not apply static electricity or excessive voltage while assembling and measuring.

19.8. Input Power Capacity:

Products shall be used in the input power capacity as specified in this specifications.
Inform Murata beforehand, in case that the components are used beyond such input power capacity range.

20. PRECONDITION TO USE OUR PRODUCTS

PLEASE READ THIS NOTICE BEFORE USING OUR PRODUCTS.

Please make sure that your product has been evaluated and confirmed from the aspect of the fitness for the specifications of our product when our product is mounted to your product.

All the items and parameters in this product specification/datasheet/catalog have been prescribed on the premise that our product is used for the purpose, under the condition and in the environment specified in this specification. You are requested not to use our product deviating from the condition and the environment specified in this specification.

Please note that the only warranty that we provide regarding the products is its conformance to the specifications provided herein. Accordingly, we shall not be responsible for any defects in products or equipment incorporating such products, which are caused under the conditions other than those specified in this specification.

WE HEREBY DISCLAIMS ALL OTHER WARRANTIES REGARDING THE PRODUCTS, EXPRESS OR IMPLIED, INCLUDING WITHOUT LIMITATION ANY WARRANTY OF FITNESS FOR A PARTICULAR PURPOSE, THAT THEY ARE DEFECT-FREE, OR AGAINST INFRINGEMENT OF INTELLECTUAL PROPERTY RIGHTS.

The product shall not be used in any application listed below which requires especially high reliability for the prevention of such defect as may directly cause damage to the third party's life, body or property. You acknowledge and agree that, if you use our products in such applications, we will not be responsible for any failure to meet such requirements. Furthermore, YOU AGREE TO INDEMNIFY AND DEFEND US AND OUR AFFILIATES AGAINST ALL CLAIMS, DAMAGES, COSTS, AND EXPENSES THAT MAY BE INCURRED, INCLUDING WITHOUT LIMITATION, ATTORNEY FEES AND COSTS, DUE TO THE USE OF OUR PRODUCTS IN SUCH APPLICATIONS.

- Aircraft equipment. - Aerospace equipment - Undersea equipment.
- Power plant control equipment - Medical equipment.
- Transportation equipment (vehicles, trains, ships, elevator, etc.).
- Traffic signal equipment. - Disaster prevention / crime prevention equipment.
- Burning / explosion control equipment
- Application of similar complexity and/ or reliability requirements to the applications listed in the above.

We expressly prohibit you from analyzing, breaking, reverse-engineering, remodeling altering, and reproducing our product. Our product cannot be used for the product which is prohibited from being manufactured, used, and sold by the regulations and laws in the world.

We do not warrant or represent that any license, either express or implied, is granted under any our patent right, copyright, mask work right, or our other intellectual property right relating to any combination, machine, or process in which our products or services are used. Information provided by us regarding third-party products or services does not constitute a license from us to use such products or services or a warranty or endorsement thereof. Use of such information may require a license from a third party under the patents or other intellectual property of the third party, or a license from us under our patents or other intellectual property.

Please do not use our products, our technical information and other data provided by us for the purpose of developing of mass-destruction weapons and the purpose of military use.

Moreover, you must comply with "foreign exchange and foreign trade law", the "U.S. export administration regulations", etc.

Please note that we may discontinue the manufacture of our products, due to reasons such as end of supply of materials and/or components from our suppliers.

By signing on specification sheet or approval sheet, you acknowledge that you are the legal representative for your company and that you understand and accept the validity of the contents herein. When you are not able to return the signed version of specification sheet or approval sheet within 30 days from receiving date of specification sheet or approval sheet, it shall be deemed to be your consent on the content of specification sheet or approval sheet. Customer acknowledges that engineering samples may deviate from specifications and may contain defects due to their development status. We reject any liability or product warranty for engineering samples. In particular we disclaim liability for damages caused by

- the use of the engineering sample other than for evaluation purposes, particularly the installation or integration in the product to be sold by you,
- deviation or lapse in function of engineering sample,
- improper use of engineering samples.

We disclaim any liability for consequential and incidental damages.

If you can't agree the above contents, you should inquire our sales.

Appendix

LBEE5ZZ1PJ Installation Manual (FCC)

FCC ID of this module is as follows;

FCC ID:	VPYLBEE5ZZ1PJ
----------------	----------------------

For OEM integration only – device cannot be sold to general public.
Therefore we will ask OEM to include the following statement required by FCC on the product and in the installation manual Notice.

Contents

1. Theory of operation
2. Antenna
3. Notice

1. Theory of operation

Frequency of operation			Scan	Ad-hoc mode
2.4GHz	802.11b/g/n-HT20	2412MHz – 2462MHz (ch1 – ch11)	Active	Yes
	802.11n-HT40	2422MHz – 2452MHz (ch3 – ch9)	Active	Yes
W52	802.11a/n-HT20/ac-VHT-20	5180MHz – 5240MHz (ch36 – ch48)	Active	Yes
	802.11n-HT40/ac-VHT-40	5190MHz – 5239MHz (ch38 – ch46)	Active	Yes
	802.11ac-VHT80	5210MHz (ch42)	Active	Yes
W53	802.11a/n-HT20/ac-VHT-20	5260MHz – 5320MHz (ch52 – ch64)	Passive	No
	802.11n-HT40/ac-VHT-40	5270MHz – 5310MHz (ch54 – ch62)	Passive	No
	802.11ac-VHT80	5290MHz (ch58)	Passive	No
W56	802.11a/n-HT20/ac-VHT-20	5500MHz – 5720MHz (ch100 – ch144)	Passive	No
	802.11n-HT40/ac-VHT-40	5510MHz – 5710MHz (ch102 – ch142)	Passive	No
	802.11ac-VHT80	5530MHz – 5690MHz (ch106 – ch138)	Passive	No
W58	802.11a/n-HT20/ac-VHT-20	5745MHz – 5825MHz (ch149 – ch165)	Active	Yes
	802.11n-HT40/ac-VHT-40	5755MHz – 5795MHz (ch151 – ch159)	Active	Yes
	802.11ac-VHT80	5775MH (ch155)	Active	Yes

The device cannot operate in 5600MHz~5650MHz band in Canada

Compliance with FCC requirement 15.407(c)

Data transmission is always initiated by software, which is the passed down through the MAC, through the digital and analog baseband, and finally to the RF chip. Several special packets are initiated by the MAC. These are the only ways the digital baseband portion will turn on the RF transmitter, which it then turns off at the end of the packet. Therefore, the transmitter will be on only while one of the aforementioned packets is being transmitted. In other words, this device automatically discontinue transmission in case of either absence of information to transmit or operational failure.

Frequency Tolerance: ± 20ppm

End users cannot modify the software because F/W & driver are installed in device.

2. Antenna

■Please refer to KDB 996369

■Please perform the antenna design that followed the specifications of the antenna.

■About the signal line between an antenna and a module

It is a 50-ohm line design.

Fine tuning of return loss etc. can be performed using a matching network.

However, it is required to check "Class1 change" and "Class2 change" which the authorities define then.

The concrete contents of a check are the following three points.

- 1) It is the same type as the antenna type of antenna specifications.
- 2) An antenna gain is lower than a gain given in antenna specifications.
- 3) The emission level is not getting worse.

■50-ohm feed line(microstrip line length)

	Antenna
Antenna type	2.4GHz Monopole Antenna 5GHz Monopole Antenna
50-ohm feed line length	We test it at 26.4mm as a representative

3. Notice

For OEM integration only – device cannot be sold to general public.

Therefore we will ask OEM to include the following statements required by FCC/IC on the product and in the Installation manual Notice.

Please describe the following warning on the final product which contains this module.

Contains Transmitter Module FCC ID: VPYLBEE5ZZ1PJ

or

Contains FCC ID: VPYLBEE5ZZ1PJ

●Please describe the following warning to the manual.

This device complies with part 15 of the FCC Rules. Operation is subject to the following two conditions: (1) This device may not cause harmful interference, and (2) this device must accept any interference received, including interference that may cause undesired operation.
FCC CAUTION Changes or modifications not expressly approved by the party responsible for compliance could void the user's authority to operate the equipment.
This transmitter must not be co-located or operated in conjunction with any other antenna or transmitter.

※When the product is small, as for these words mentioned above, the posting to a manual is possible.

●When installing it in a mobile equipment. Please describe the following warning to the manual.

This equipment complies with FCC radiation exposure limits set forth for an uncontrolled environment and meets the FCC radio frequency (RF) Exposure Guidelines. This equipment should be installed and operated keeping the radiator at least 20cm or more away from person's body.

RF Exposure requirements are met when installed in mobile equipment.

This module cannot be installed in portable equipment without further testing and a change to FCC's grant of authorization. Contact Murata regarding portable applications.

Note)

Portable equipment : Equipment for which the spaces between human body and antenna are used within 20cm.

Mobile equipment : Equipment used at position in which the spaces between human body and antenna exceeded 20cm.

This device is intended only for OEM integrators under the following conditions:

- 1) The antenna must be installed such that 20 cm is maintained between the antenna and users, and
- 2) The transmitter module may not be co-located with any other transmitter or antenna.
- 3) The use of an antenna with gain less than 2.0 dBi(2.4GHz), 2.0 dBi(5.15~5.35GHz), 1.2 dBi (5.47~5.725GHz) and 1.0 dBi (5.725~5.85GHz).

As long as 3 conditions above are met, further transmitter test will not be required. However, the OEM integrator is still responsible for testing their end-product for any additional compliance requirements required with this module installed

IMPORTANT NOTE: In the event that these conditions cannot be met (for example certain laptop configurations or co-location with another transmitter), then the FCC authorization is no longer considered valid and the FCC ID cannot be used on the final product. In these circumstances, the OEM integrator will be responsible for re-evaluating the end product (including the transmitter) and obtaining a separate FCC authorization.

End Product Labeling

This transmitter module is authorized only for use in device where the antenna may be installed such that 20 cm may be maintained between the antenna and users. The final end product must be labeled in a visible area with the following: "Contains FCC ID: **VPYLBEE5ZZ1PJ**". The grantee's FCC ID can be used only when all FCC compliance requirements are met.

Manual Information To the End User

The OEM integrator has to be aware not to provide information to the end user regarding how to install or remove this RF module in the user's manual of the end product which integrates this module.

The end user manual shall include all required regulatory information/warning as show in this manual.

LBEE5ZZ1PJ Installation Manual (IC)

IC No. of this device is as follows;

IC:	772C-LBEE5ZZ1PJ
------------	------------------------

For OEM integration only – device cannot be sold to general public.
Therefore, we will ask OEM to include the following statements required by IC on the product and in the installation manual Notice.

Contents

1. Theory of operation
2. Antenna
3. Notice

1. Theory of operation

Frequency of operation			Scan	Ad-hoc mode
2.4GHz	802.11b/g/n-HT20	2412MHz – 2462MHz (ch1 – ch11)	Active	Yes
	802.11n-HT40	2422MHz – 2452MHz (ch3 – ch9)	Active	Yes
W52	802.11a/n-HT20/ac-VHT-20	5180MHz – 5240MHz (ch36 – ch48)	Active	Yes
	802.11n-HT40/ac-VHT-40	5190MHz – 5239MHz (ch38 – ch46)	Active	Yes
	802.11ac-VHT80	5210MHz (ch42)	Active	Yes
W53	802.11a/n-HT20/ac-VHT-20	5260MHz – 5320MHz (ch52 – ch64)	Passive	No
	802.11n-HT40/ac-VHT-40	5270MHz – 5310MHz (ch54 – ch62)	Passive	No
	802.11ac-VHT80	5290MHz (ch58)	Passive	No
W56	802.11a/n-HT20/ac-VHT-20	5500MHz – 5720MHz (ch100 – ch144)	Passive	No
	802.11n-HT40/ac-VHT-40	5510MHz – 5710MHz (ch102 – ch142)	Passive	No
	802.11ac-VHT80	5530MHz – 5690MHz (ch106 – ch138)	Passive	No
W58	802.11a/n-HT20/ac-VHT-20	5745MHz – 5825MHz (ch149 – ch165)	Active	Yes
	802.11n-HT40/ac-VHT-40	5755MHz – 5795MHz (ch151 – ch159)	Active	Yes
	802.11ac-VHT80	5775MH (ch155)	Active	Yes

The device cannot operate in 5600MHz~5650MHz band in Canada

Data transmission is always initiated by software, which is the passed down through the MAC, through the digital and analog baseband, and finally to the RF chip. Several special packets are initiated by the MAC. These are the only ways the digital baseband portion will turn on the RF transmitter, which it then turns off at the end of the packet. Therefore, the transmitter will be on only while one of the aforementioned packets is being transmitted. In other words, this device automatically discontinue transmission in case of either absence of information to transmit or operational failure.

La transmission des données est toujours initiée par le logiciel, puis les données sont transmises par l'intermédiaire du MAC, par la bande de base numérique et analogique et, enfin, à la puce RF. Plusieurs paquets spéciaux sont initiés par le MAC. Ce sont les seuls moyens pour qu'une partie de la bande de base numérique active l'émetteur RF, puis désactive celui-ci à la fin du paquet. En conséquence, l'émetteur reste uniquement activé lors de la transmission d'un des paquets susmentionnés. En d'autres termes, ce dispositif interrompt automatiquement toute transmission en cas d'absence d'information à transmettre ou de défaillance.

End users cannot modify the software because F/W & driver are installed in device.

2. Antenna

■Please refer to KDB 996369

■Please perform the antenna design that followed the specifications of the antenna.

■About the signal line between an antenna and a module

It is a 50-ohm line design.

Fine tuning of return loss etc. can be performed using a matching network.

However, it is required to check "Class1 change" and "Class2 change" which the authorities define then.

The concrete contents of a check are the following three points.

- 1) It is the same type as the antenna type of antenna specifications.
- 2) An antenna gain is lower than a gain given in antenna specifications.
- 3) The emission level is not getting worse.

■50-ohm feed line(microstrip line length)

	Antenna
Antenna type	2.4GHz Monopole Antenna 5GHz Monopole Antenna
50-ohm feed line length	We test it at 26.4mm as a representative

3. Notice

For OEM integration only – device cannot be sold to general public.

Therefore we will ask OEM to include the following statements required by FCC/IC on the product and in the Installation manual Notice.

Please describe the following warning on the final product which contains this module.

Contains IC: 772C-LBEE5ZZ1PJ

This device complies with Industry Canada's licence-exempt RSSs. Operation is subject to the following two conditions:

- (1) This device may not cause interference; and
- (2) This device must accept any interference, including interference that may cause undesired operation of the device.

Le présent appareil est conforme aux CNR d'Industrie Canada applicables aux appareils radio exempts de licence.

L'exploitation est autorisée aux deux conditions suivantes :

- 1) l'appareil ne doit pas produire de brouillage;
- 2) l'utilisateur de l'appareil doit accepter tout brouillage radioélectrique subi, même si le brouillage est susceptible d'en compromettre le fonctionnement.

*When the product is small, as for these words mentioned above, the posting to a manual is possible.

5150-5250 MHz band is restricted to indoor operation only.

La bande 5150-5250 MHz est restreinte à une utilisation à l'intérieur seulement.

High-power radars are allocated as primary users (i.e. priority users) of the bands 5250-5350 MHz and 5650-5850 MHz and that these radars could cause interference and/or damage to LE-LAN devices.

Les radars de haute puissance sont désignés utilisateurs principaux (c.-à-d., qu'ils ont la priorité) pour les bandes 5250-5350 MHz et 5650-5850 MHz, et ces radars pourraient causer du brouillage et/ou des dommages aux dispositifs LAN-EL.

- When installing it in a mobile equipment. Please describe the following warning to the manual.

This equipment complies with IC radiation exposure limits set forth for an uncontrolled environment and meets RSS-102 of the IC radio frequency (RF) Exposure rules. This equipment should be installed and operated keeping the radiator at least 20cm or more away from person's body.

Cet équipement est conforme aux limites d'exposition aux rayonnements énoncées pour un environnement non contrôlé et respecte les règles d'exposition aux fréquences radioélectriques (RF) CNR-102 de l'IC. Cet équipement doit être installé et utilisé en gardant une distance de 20 cm ou plus entre le radiateur et le corps humain.

RF Exposure requirements are met when installed in mobile equipment.

This module cannot be installed in portable equipment without further testing and a change to FCC's grant of authorization.

Contact Murata regarding portable applications.

Note)

Portable equipment : Equipment for which the spaces between human body and antenna are used within 20cm.

Mobile equipment : Equipment used at position in which the spaces between human body and antenna exceeded 20cm.

This device is intended only for OEM integrators under the following conditions: (For module device use)

- 1) The antenna must be installed such that 20 cm is maintained between the antenna and users, and
- 2) The transmitter module may not be co-located with any other transmitter or antenna.
- 3) The use of an antenna with gain less than 2.0 dBi (2.4GHz), 2.0dBi (5.15~5.35GHz), 1.2dBi (5.47~5.725GHz) and 1.0dBi (5.725~5.85GHz).

As long as 3 conditions above are met, further transmitter test will not be required. However, the OEM integrator is still responsible for testing their end-product for any additional compliance requirements required with this module installed.

Cet appareil est conçu uniquement pour les intégrateurs OEM dans les conditions suivantes: (Pour utilisation de dispositif module)

- 1) L'antenne doit être installée de telle sorte qu'une distance de 20 cm est respectée entre l'antenne et les utilisateurs, et
- 2) Le module émetteur peut ne pas être coimplanté avec un autre émetteur ou antenne.

Tant que les 3 conditions ci-dessus sont remplies, des essais supplémentaires sur l'émetteur ne seront pas nécessaires. Toutefois, l'intégrateur OEM est toujours responsable des essais sur son produit final pour toutes exigences de conformité supplémentaires requis pour ce module installé.

Data transmission is always initiated by software, which is the passed down through the MAC, through the digital and analog baseband, and finally to the RF chip. Several special packets are initiated by the MAC. These are the only ways the digital baseband portion will turn on the RF transmitter, which it then turns off at the end of the packet. Therefore, the transmitter will be on only while one of the aforementioned packets is being transmitted. In other words, this device automatically discontinues transmission in case of either absence of information to transmit or operational failure.

La transmission des données est toujours initiée par le logiciel, puis les données sont transmises par l'intermédiaire du MAC, par la bande de base numérique et analogique et, enfin, à la puce RF. Plusieurs paquets spéciaux sont initiés par le MAC. Ce sont les seuls moyens pour qu'une partie de la bande de base numérique active l'émetteur RF, puis désactive celui-ci à la fin du paquet. En conséquence, l'émetteur reste uniquement activé lors de la transmission d'un des paquets susmentionnés. En d'autres termes, ce dispositif interrompt automatiquement toute transmission en cas d'absence d'information à transmettre ou de défaillance.

IMPORTANT NOTE:

In the event that these conditions cannot be met (for example certain laptop configurations or co-location with another transmitter), then the Canada authorization is no longer considered valid and the IC ID cannot be used on the final product. In these circumstances, the OEM integrator will be responsible for re-evaluating the end product (including the transmitter) and obtaining a separate Canada authorization.

NOTE IMPORTANTE:

Dans le cas où ces conditions ne peuvent être satisfaites (par exemple pour certaines configurations d'ordinateur portable ou de certaines co-localisation avec un autre émetteur), l'autorisation du Canada n'est plus considéré comme valide et l'ID IC ne peut pas être utilisé sur le produit final. Dans ces circonstances, l'intégrateur OEM sera chargé de réévaluer le produit final (y compris l'émetteur) et l'obtention d'une autorisation distincte au Canada.

End Product Labeling

This transmitter module is authorized only for use in device where the antenna may be installed such that 20 cm may be maintained between the antenna and users. The final end product must be labeled in a visible area with the following: "Contains IC: **772C-LBEE5ZZ1PJ**".

Plaque signalétique du produit final

Ce module émetteur est autorisé uniquement pour une utilisation dans un dispositif où l'antenne peut être installée de telle sorte qu'une distance de 20cm peut être maintenue entre l'antenne et les utilisateurs. Le produit final doit être étiqueté dans un endroit visible avec l'inscription suivante: "Contient des IC: **772C-LBEE5ZZ1PJ**".

Manual Information To the End User

The OEM integrator has to be aware not to provide information to the end user regarding how to install or remove this RF module in the user's manual of the end product which integrates this module. The end user manual shall include all required regulatory information/warning as show in this manual.



Manuel d'information à l'utilisateur final

L'intégrateur OEM doit être conscient de ne pas fournir des informations à l'utilisateur final quant à la façon d'installer ou de supprimer ce module RF dans le manuel de l'utilisateur du produit final qui intègre ce module.



Le manuel de l'utilisateur final doit inclure toutes les informations réglementaires requises et avertissements comme indiqué dans ce manuel.

Looking for pricing, stock, or lifecycle information?

Click below to explore more details on WIN SOURCE:

-  [View LBEE5ZZ1PJ-164 on WIN SOURCE](#)
-  [Murata Electronics North America Information](#)

Optimize Your Supply Chain with WIN SOURCE Solutions

-  Global Sourcing Solution
-  Obsolete Management
-  Cost Control Management
-  Shortage Management
-  Alternative Solution
-  Excess Inventory Management