

PCL Chip Type, Higher Capacitance
LongLife Assurance



- Long life of 20000 hours at 105°C.
- High reliability, Low ESR, High ripple current.
- SMD type : Lead free reflow soldering condition at 260°C peak correspondence.
- Compliant to the RoHS directive (2011/65/EU,(EU)2015/863).
- AEC-Q200 Qualified. Please contact us for details.



■ Specifications

Item	Performance Characteristics		
Category Temperature Range	-55 to +105°C		
Rated Voltage Range	2.5 to 25V		
Rated Capacitance Range	12 to 3300μF		
Capacitance Tolerance	±20% at 120Hz, 20°C		
Tangent of loss angle (tan δ)	Less than or equal to the specified value at 120Hz, 20°C		
ESR (※ 1)	Less than or equal to the specified value at 100kHz, 20°C		
Leakage Current (※ 2)	Less than or equal to the specified value . After 2 minutes' application of rated voltage at 20°C		
Temperature Characteristics (Max.Impedance Ratio)	$Z(+105^{\circ}\text{C}) / Z(+20^{\circ}\text{C}) \leq 1.25$ (100kHz) $Z(-55^{\circ}\text{C}) / Z(+20^{\circ}\text{C}) \leq 1.25$		
Endurance	The specifications listed at right shall be met when the capacitors are restored to 20°C after the rated voltage is applied for 20000 hours at 105°C.	Capacitance change	Within ± 20% of the initial capacitance value (※ 3)
		tan δ	150% or less than the initial specified value
		ESR (※ 1)	150% or less than the initial specified value
		Leakage current (※ 2)	Less than or equal to the initial specified value
Damp Heat (Steady State)	The specifications listed at right shall be met when the capacitors are restored to 20°C after the rated voltage is applied for 1000 hours at 60°C, 90% RH.	Capacitance change	Within ± 20% of the initial capacitance value (※ 3)
		tan δ	150% or less than the initial specified value
		ESR (※ 1)	150% or less than the initial specified value
		Leakage current (※ 2)	Less than or equal to the initial specified value
Resistance to Soldering Heat	After soldering the capacitor under the soldering conditions prescribed here, the capacitor shall meet the specifications listed at right. Pre-heating shall be done at 150 to 200°C and for 60 to 180 sec. The duration for over +230°C temperature at capacitor surface shall not exceed 60 seconds. In case peak temperature is 250°C or less, reflow soldering shall be two times maximum. In case peak temperature is 260°C or less, reflow soldering shall be once. Measurement for solder temperature profile shall be made at the capacitor top.	Capacitance change	Within ± 10% of the initial capacitance value (※ 3)
		tan δ	130% or less than the initial specified value
		ESR (※ 1)	130% or less than the initial specified value
		Leakage current (※ 2)	Less than or equal to the initial specified value
Marking	Navy blue print on the case top		

- ※ 1 ESR should be measured at both of the terminal ends closest where the terminals protrude through the plastic platform.
- ※ 2 Conditioning : If any doubt arises, measure the leakage current after the voltage treatment of applying DC rated voltage continuously to the capacitor for 120 minutes at 105°C.
- ※ 3 Initial value : The value before test of examination of resistance to soldering.

■ Dimensions

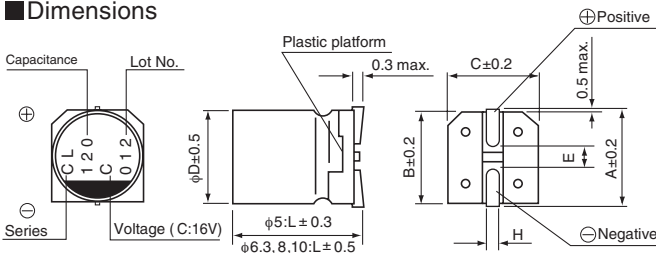

	(mm)						
Size	φ5 × 6L	φ6.3 × 6L	φ8 × 7L	φ8 × 10L	φ8 × 12L	φ10 × 10L	φ10 × 12.7L
φD	5.0	6.3	8.0	8.0	8.0	10.0	10.0
L	5.9	6.0	6.9	9.9	11.9	9.9	12.6
A	6.0	7.3	9.0	9.0	9.0	11.0	11.0
B	5.3	6.6	8.3	8.3	8.3	10.3	10.3
C	5.3	6.6	8.3	8.3	8.3	10.3	10.3
E	1.6	2.1	3.2	3.2	3.2	4.6	4.6
H	0.5 to 0.8	0.5 to 0.8	0.8 to 1.1	0.8 to 1.1	0.8 to 1.1	0.8 to 1.1	0.8 to 1.1

● Dimension table in next page.

Type numbering system (Example : 16V 120μF)

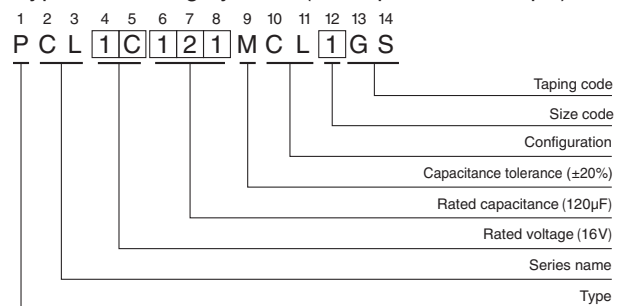

Voltage

V	2.5	4	6.3	10	16	20	25
Code	e	g	j	A	C	D	E

● Frequency coefficient of rated ripple current

Frequency	120Hz	1kHz	10kHz	100kHz or more
Coefficient	0.05	0.30	0.70	1.00





■ Dimensions

Rated Voltage (V) (code)	Surge Voltage (V)	Rated Capacitance (μF)	Case Size φD×L (mm)	tan δ	Leakage Current (μA) (at 20°C after 2 minutes)	ESR (mΩ) (20°C /100kHz)	Rated Ripple (mArms) (105°C /100kHz)	Part Number
2.5 (0E)	2.8	270	5×6	0.12	337	25	2670	PCL0E271MCL1GS
		2200	8×12	0.12	1100	14	5220	PCL0E222MCL1GS
		2700	10×10	0.12	1350	12	5500	PCL0E272MCL1GS
		3300	10×12.7	0.12	1650	11	5500	PCL0E332MCL1GS
4 (0G)	4.6	150	5×6	0.12	300	25	2100	PCL0G151MCL1GS
		180	5×6	0.12	360	25	2300	PCL0G181MCL1GS
		390	6.3×6	0.12	312	24	2700	PCL0G391MCL1GS
		560	8×7	0.12	448	22	3200	PCL0G561MCL1GS
		1200	8×10	0.12	960	15	5400	PCL0G122MCL1GS
		1800	8×12	0.12	1440	14	5500	PCL0G182MCL1GS
		2200	10×10	0.12	1760	12	5400	PCL0G222MCL1GS
		2700	10×12.7	0.12	2160	11	5600	PCL0G272MCL1GS
6.3 (0J)	7.2	47	5×6	0.12	148	30	1900	PCL0J470MCL1GS
		220	6.3×6	0.12	277	22	2500	PCL0J221MCL1GS
		330	8×7	0.12	415	14	3900	PCL0J331MCL1GS
		680	8×10	0.12	856	12	4600	PCL0J681MCL1GS
		1000	8×12	0.12	1260	11	4800	PCL0J102MCL1GS
		1800	10×12.7	0.12	2268	10	5500	PCL0J182MCL1GS
10 (1A)	11.5	33	5×6	0.12	165	70	1100	PCL1A330MCL1GS
		68	5×6	0.12	340	30	1900	PCL1A680MCL1GS
		120	6.3×6	0.12	240	30	2700	PCL1A121MCL1GS
		150	8×7	0.12	300	21	2880	PCL1A151MCL1GS
		470	8×10	0.12	940	17	3800	PCL1A471MCL1GS
		820	10×10	0.12	1640	15	4300	PCL1A821MCL1GS
		1200	10×12.7	0.12	2400	13	4800	PCL1A122MCL1GS
16 (1C)	18.4	22	5×6	0.12	176	90	1000	PCL1C220MCL1GS
		39	6.3×6	0.12	124	37	2000	PCL1C390MCL1GS
		82	6.3×6	0.12	262	30	2700	PCL1C820MCL1GS
		120	8×7	0.12	384	27	2900	PCL1C121MCL1GS
		270	8×10	0.12	864	20	3600	PCL1C271MCL1GS
		390	8×12	0.12	1248	18	3900	PCL1C391MCL1GS
		470	10×10	0.12	1504	16	4200	PCL1C471MCL1GS
		680	10×12.7	0.12	2176	14	4700	PCL1C681MCL1GS
20 (1D)	23.0	27	6.3×6	0.12	108	60	1400	PCL1D270MCL1GS
		39	8×7	0.12	156	45	2000	PCL1D390MCL1GS
		100	8×12	0.12	400	22	3200	PCL1D101MCL1GS
		180	10×12.7	0.12	720	20	4300	PCL1D181MCL1GS
25 (1E)	28.7	12	6.3×6	0.12	100	70	1200	PCL1E120MCL1GS
		33	8×10	0.12	165	50	2000	PCL1E330MCL1GS
		56	10×10	0.12	280	45	2200	PCL1E560MCL1GS
		82	10×12.7	0.12	410	30	3800	PCL1E820MCL1GS







● For taping specifications, recommended land size/soldering by reflow and minimum order quantity, please refer to the Guidelines for Aluminum Electrolytic Capacitors.

Looking for pricing, stock, or lifecycle information?

Click below to explore more details on WIN SOURCE:

-  [View PCL0J182MCL1GS on WIN SOURCE](#)
-  [Nichicon Information](#)

Optimize Your Supply Chain with WIN SOURCE Solutions

-  Global Sourcing Solution
-  Obsolete Management
-  Cost Control Management
-  Shortage Management
-  Alternative Solution
-  Excess Inventory Management