



RF LDMOS Wideband Integrated Power Amplifiers

The MD7IC18120N/GN wideband integrated circuit is designed with on-chip matching that makes it usable from 1805 to 1880 MHz. This multi-stage structure is rated for 26 to 32 Volt operation and covers all typical cellular base station modulation formats.

- Typical Doherty Single-Carrier W-CDMA Performance: $V_{DD} = 28$ Volts, $I_{DQ1A} = 70$ mA, $I_{DQ1B} = 160$ mA, $I_{DQ2B} = 500$ mA, $V_{GS2A} = 1.7$ Vdc, $P_{out} = 30$ Watts Avg., IQ Magnitude Clipping, Channel Bandwidth = 3.84 MHz, Input Signal PAR = 7.5 dB @ 0.01% Probability on CCDF.

Frequency	G_{ps} (dB)	PAE (%)	Output PAR (dB)
1805 MHz	25.7	36.7	6.9
1840 MHz	25.7	36.3	6.9
1880 MHz	25.8	35.3	6.7

- Capable of Handling 10:1 VSWR, @ 32 Vdc, 1840 MHz, 140 Watts CW Output Power
- Stable into a 5:1 VSWR. All Spurs Below -60 dBc @ 100 Watts CW P_{out}
- Typical P_{out} @ 1 dB Compression Point \approx 120 Watts CW

Features

- Production Tested in a Symmetrical Doherty Configuration
- 100% PAR Tested for Guaranteed Output Power Capability
- Characterized with Large-Signal Load-Pull Parameters and Common Source S-Parameters
- On-Chip Matching (50 Ohm Input, DC Blocked)
- Integrated Quiescent Current Temperature Compensation with Enable/Disable Function (1)
- Integrated ESD Protection
- Greater Negative Gate-Source Voltage Range for Improved Class C Operation
- 225°C Capable Plastic Package
- RoHS Compliant
- In Tape and Reel. R1 Suffix = 500 Units per 44 mm, 13 inch Reel.

MD7IC18120NR1 MD7IC18120GNR1

1805-1880 MHz, 30 W AVG., 28 V
 SINGLE W-CDMA
 RF LDMOS WIDEBAND
 INTEGRATED POWER AMPLIFIERS

CASE 1866-02
 TO-270 WBL-16
 PLASTIC
 MD7IC18120NR1

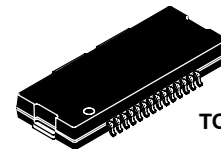
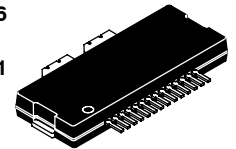

CASE 1867-02
 TO-270 WBL-16 GULL
 PLASTIC
 MD7IC18120GNR1

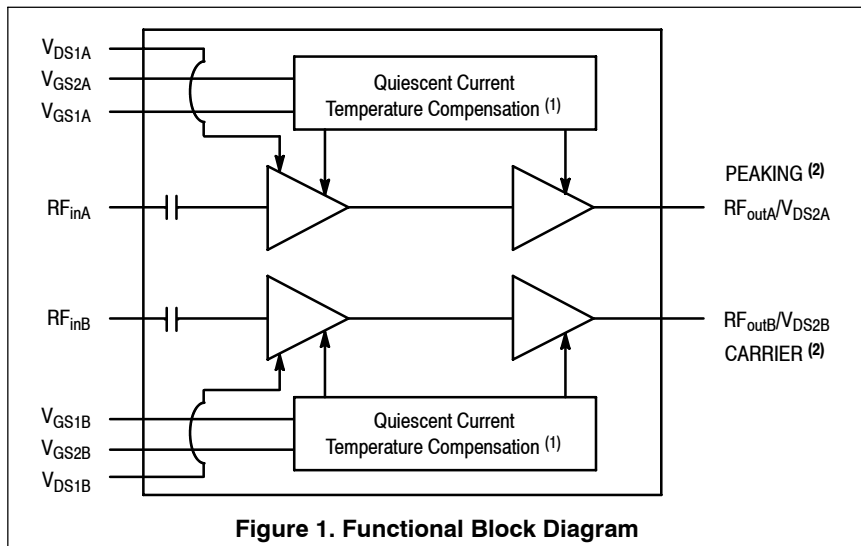
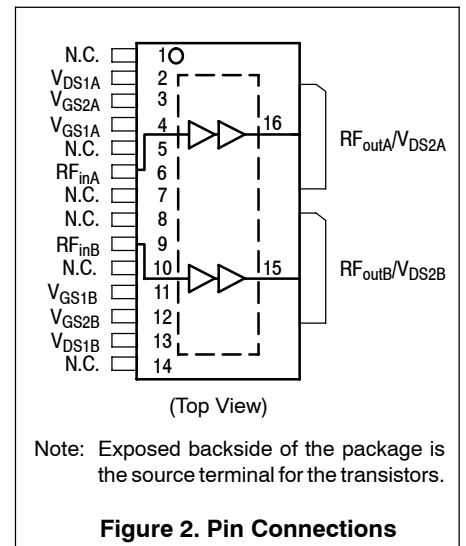

Figure 1. Functional Block Diagram



Note: Exposed backside of the package is the source terminal for the transistors.

Figure 2. Pin Connections

1. Refer to AN1977, *Quiescent Current Thermal Tracking Circuit in the RF Integrated Circuit Family* and to AN1987, *Quiescent Current Control for the RF Integrated Circuit Device Family*. Go to <http://www.freescale.com/rf>. Select Documentation/Application Notes - AN1977 or AN1987.
 2. Peaking and Carrier orientation is determined by the test fixture design.

Table 1. Maximum Ratings

Rating	Symbol	Value	Unit
Drain-Source Voltage	V_{DSS}	-0.5, +65	Vdc
Gate-Source Voltage	V_{GS}	-6.0, +10	Vdc
Operating Voltage	V_{DD}	32, +0	Vdc
Storage Temperature Range	T_{stg}	-65 to +150	°C
Case Operating Temperature	T_C	150	°C
Operating Junction Temperature (1,2)	T_J	225	°C
CW Operation @ $T_C = 25^\circ\text{C}$ Derate above 25°C	CW	175 1.5	W W/°C
Input Power	P_{in}	30	dBm

Table 2. Thermal Characteristics

Characteristic	Symbol	Value (2,3)	Unit
----------------	--------	-------------	------

Final Doherty Application

Characteristic	Symbol	Value	Unit
Thermal Resistance, Junction to Case Case Temperature 78°C, $P_{out} = 30$ W CW, 1880 MHz Stage 1A, 28 Vdc, $I_{DQ1A} = 70$ mA Stage 1B, 28 Vdc, $I_{DQ1B} = 160$ mA Stage 2A, 28 Vdc, $V_{G2A} = 1.7$ Vdc Stage 2B, 28 Vdc, $I_{DQ2B} = 500$ mA	$R_{\theta JC}$	4.5 4.5 0.88 0.88	°C/W

Table 3. ESD Protection Characteristics

Test Methodology	Class
Human Body Model (per JESD22-A114)	2 (Minimum)
Machine Model (per EIA/JESD22-A115)	A (Minimum)
Charge Device Model (per JESD22-C101)	III (Minimum)

Table 4. Moisture Sensitivity Level

Test Methodology	Rating	Package Peak Temperature	Unit
Per JESD22-A113, IPC/JEDEC J-STD-020	3	260	°C

1. Continuous use at maximum temperature will affect MTTF.
2. MTTF calculator available at <http://www.freescale.com/rf>. Select Software & Tools/Development Tools/Calculators to access MTTF calculators by product.
3. Refer to AN1955, *Thermal Measurement Methodology of RF Power Amplifiers*. Go to <http://www.freescale.com/rf>. Select Documentation/Application Notes - AN1955.

Table 5. Electrical Characteristics ($T_A = 25^\circ\text{C}$ unless otherwise noted)

Characteristic	Symbol	Min	Typ	Max	Unit
Stage 1 — Off Characteristics (1)					
Zero Gate Voltage Drain Leakage Current ($V_{DS} = 65\text{ Vdc}$, $V_{GS} = 0\text{ Vdc}$)	I_{DSS}	—	—	10	μAdc
Zero Gate Voltage Drain Leakage Current ($V_{DS} = 28\text{ Vdc}$, $V_{GS} = 0\text{ Vdc}$)	I_{DSS}	—	—	1	μAdc
Gate-Source Leakage Current ($V_{GS} = 1.5\text{ Vdc}$, $V_{DS} = 0\text{ Vdc}$)	I_{GSS}	—	—	1	μAdc

Stage 1 — On Characteristics (1)

Gate Threshold Voltage ($V_{DS} = 10\text{ Vdc}$, $I_D = 28\ \mu\text{Adc}$)	$V_{GS(th)}$	1.2	2.0	2.7	Vdc
Gate Quiescent Voltage ($V_{DS} = 28\text{ Vdc}$, $I_{DQ1A} = 70\text{ mA}$, $I_{DQ1B} = 160\text{ mA}$)	$V_{GS(Q)}$	—	2.9	—	Vdc
Fixture Gate Quiescent Voltage ($V_{DD} = 28\text{ Vdc}$, Measured in Functional Test)	$I_{DQ1A} = 70\text{ mA}$ $I_{DQ1B} = 160\text{ mA}$ $V_{GG(Q)}$	4.0 7.1	5.0 8.1	6.0 9.1	Vdc

Stage 2 — Off Characteristics (1)

Zero Gate Voltage Drain Leakage Current ($V_{DS} = 65\text{ Vdc}$, $V_{GS} = 0\text{ Vdc}$)	I_{DSS}	—	—	10	μAdc
Zero Gate Voltage Drain Leakage Current ($V_{DS} = 28\text{ Vdc}$, $V_{GS} = 0\text{ Vdc}$)	I_{DSS}	—	—	1	μAdc
Gate-Source Leakage Current ($V_{GS} = 1.5\text{ Vdc}$, $V_{DS} = 0\text{ Vdc}$)	I_{GSS}	—	—	1	μAdc

Stage 2 — On Characteristics (1)

Gate Threshold Voltage ($V_{DS} = 10\text{ Vdc}$, $I_D = 185\ \mu\text{Adc}$)	$V_{GS(th)}$	1.2	2.0	2.7	Vdc
Gate Quiescent Voltage ($V_{DS} = 28\text{ Vdc}$, $I_{DQ2B} = 500\text{ mA}$)	$V_{GS(Q)}$	—	2.6	—	Vdc
Fixture Gate Quiescent Voltage ($V_{DD} = 28\text{ Vdc}$, $I_{DQ2B} = 500\text{ mA}$, Measured in Functional Test)	$V_{GG(Q)}$	5.3	6.3	7.3	Vdc
Drain-Source On-Voltage ($V_{GS} = 10\text{ Vdc}$, $I_D = 1.8\text{ Adc}$)	$V_{DS(on)}$	—	0.35	—	Vdc

Functional Tests (2,3,4) (In Freescale Test Fixture, 50 ohm system) $V_{DD} = 28\text{ Vdc}$, $I_{DQ1A} = 70\text{ mA}$, $I_{DQ1B} = 160\text{ mA}$, $I_{DQ2B} = 500\text{ mA}$, $V_{GS2A} = 1.7\text{ Vdc}$, $P_{out} = 30\text{ W Avg.}$, $f = 1880\text{ MHz}$, Single-Carrier W-CDMA, IQ Magnitude Clipping, Input Signal PAR = 7.5 dB @ 0.01% Probability on CCDF.

Power Gain	G_{ps}	24.0	25.8	28.0	dB
Power Added Efficiency	PAE	33.0	35.3	—	%
Output Peak-to-Average Ratio @ 0.01% Probability on CCDF	PAR	6.0	6.7	—	dB

1. Each side of device measured separately.
2. Part internally matched both on input and output.
3. Measurement made with device in a Symmetrical Doherty configuration.
4. Measurement made with device in straight lead configuration before any lead forming operation is applied.

(continued)

Table 5. Electrical Characteristics ($T_A = 25^\circ\text{C}$ unless otherwise noted) (continued)

Typical Broadband Performance ⁽¹⁾ (In Freescale Test Fixture, 50 ohm system) $V_{DD} = 28\text{ Vdc}$, $I_{DQ1A} = 70\text{ mA}$, $I_{DQ1B} = 160\text{ mA}$, $I_{DQ2B} = 500\text{ mA}$, $V_{GS2A} = 1.7\text{ Vdc}$, $P_{out} = 30\text{ W Avg.}$, Single-Carrier W-CDMA, IQ Magnitude Clipping, Input Signal PAR = 7.5 dB @ 0.01% Probability on CCDF. ACPR measured in 3.84 MHz Channel Bandwidth @ $\pm 5\text{ MHz}$ Offset.

Frequency	G_{ps} (dB)	PAE (%)	Output PAR (dB)
1805 MHz	25.7	36.7	6.9
1840 MHz	25.7	36.3	6.9
1880 MHz	25.8	35.3	6.7

Typical Performances ⁽¹⁾ (In Freescale Doherty Test Fixture, 50 ohm system) $V_{DD} = 28\text{ Vdc}$, $I_{DQ1A} = 70\text{ mA}$, $I_{DQ1B} = 160\text{ mA}$, $I_{DQ2B} = 500\text{ mA}$, $V_{GS2A} = 1.7\text{ Vdc}$, 1805-1880 MHz Bandwidth

Characteristic	Symbol	Min	Typ	Max	Unit
P_{out} @ 1 dB Compression Point, CW	P1dB	—	120	—	W
IMD Symmetry @ 30 W PEP, P_{out} where IMD Third Order Intermodulation $\cong 30\text{ dBc}$ (Delta IMD Third Order Intermodulation between Upper and Lower Sidebands > 2 dB)	IMD _{sym}	—	15	—	MHz
VBW Resonance Point (IMD Third Order Intermodulation Inflection Point)	VBW _{res}	—	35	—	MHz
Gain Flatness in 75 MHz Bandwidth @ $P_{out} = 30\text{ W Avg.}$	G_F	—	0.3	—	dB
Quiescent Current Accuracy over Temperature with 2 k Ω Gate Feed Resistors (-30 to 85°C) ⁽²⁾	ΔI_{QT}	—	4.26 5.04	—	%
Gain Variation over Temperature (-30°C to +85°C)	ΔG	—	0.04	—	dB/°C
Output Power Variation over Temperature (-30°C to +85°C)	$\Delta P1dB$	—	0.04	—	dBm/°C

1. Measurement made with device in a Symmetrical Doherty configuration.
2. Refer to AN1977, *Quiescent Current Thermal Tracking Circuit in the RF Integrated Circuit Family* and to AN1987, *Quiescent Current Control for the RF Integrated Circuit Device Family*. Go to <http://www.freescale.com/rf>. Select Documentation/Application Notes - AN1977 or AN1987.

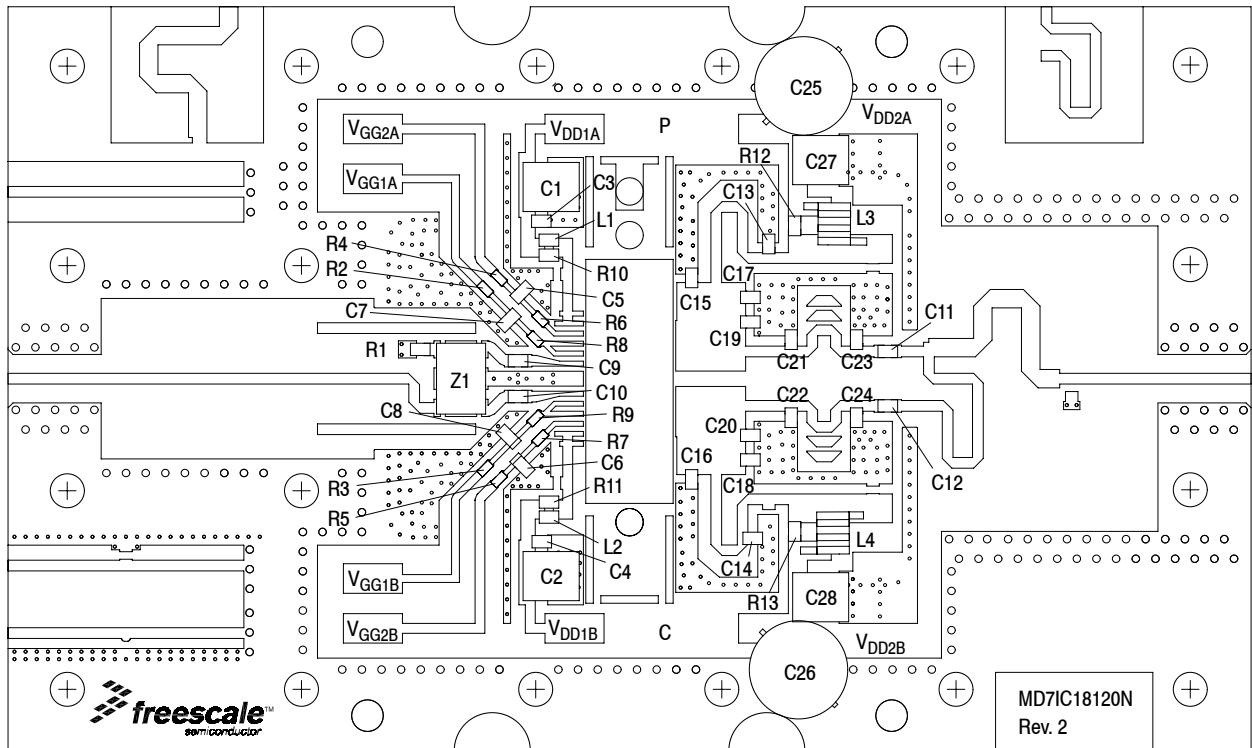

Figure 3. MD7IC18120NR1(GNR1) Test Circuit Component Layout

Table 6. MD7IC18120NR1(GNR1) Test Circuit Component Designations and Values

Part	Description	Part Number	Manufacturer
C1, C2, C27, C28	10 μ F, 50 V Chip Capacitors	GRM55DR61H106KA88L	Murata
C3, C4, C5, C6, C7, C8	0.1 μ F Chip Capacitors	GRM21BR71H104KA01B	Murata
C9, C10, C11, C13, C14	10 pF Chip Capacitors	ATC600F100JT250XT	ATC
C12	100 pF Chip Capacitor	ATC600F101JT250XT	ATC
C15, C16, C17, C18	2.2 pF Chip Capacitors	ATC600F2R2BT250XT	ATC
C19, C20	1.5 pF Chip Capacitors	ATC600F1R5BT250XT	ATC
C21, C22, C23	1.0 pF Chip Capacitors	ATC600F1R0BT250XT	ATC
C24	0.5 pF Chip Capacitor	ATC600F0R5BT250XT	ATC
C25, C26	330 μ F, 35 V Electrolytic Capacitors	MCGPR35V337M10X16-RH	Panasonic
L1, L2	6.8 nH Chip Inductors	0805CS-060XJLB	CoilCraft
L3, L4	2.5 nH, 1 Turn Inductors	A01TKLC	CoilCraft
R1	50 Ω , 1/8 W Chip Resistor	SG732ATTDD51R0F	KOA Speer
R2, R3, R4, R5, R6, R7, R8, R9	1000 Ω , 1/10 W Chip Resistors	SG731JTTDD1001F	KOA Speer
R10, R11, R12, R13	10 Ω , 1/10 W Chip Resistors	CRCW060310R0FKEA	Vishay
Z1	1900 MHz Band 90°, 3 dB Chip Hybrid Coupler	GSC351-HYB1900	SOSHIN
PCB	0.020", $\epsilon_r = 3.5$	RO4350B	Rogers

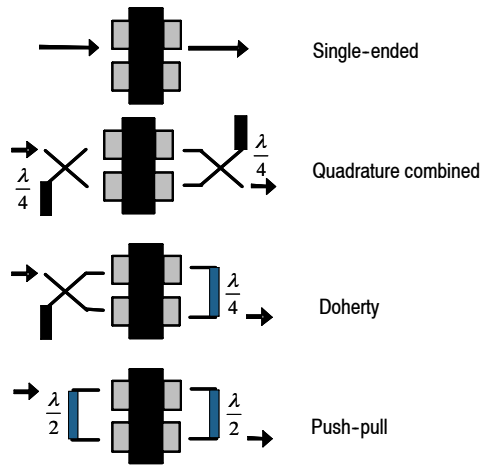

Figure 4. Possible Circuit Topologies

TYPICAL CHARACTERISTICS

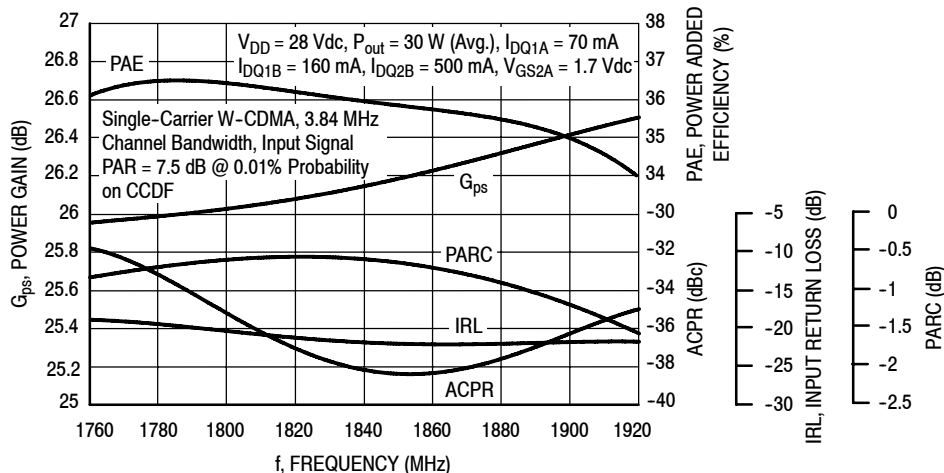

Figure 5. Output Peak-to-Average Ratio Compression (PARC) Broadband Performance @ P_{out} = 30 Watts Avg.

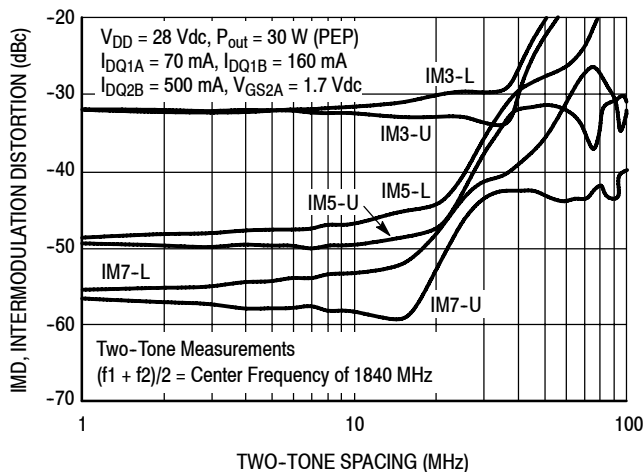

Figure 6. Intermodulation Distortion Products versus Two-Tone Spacing

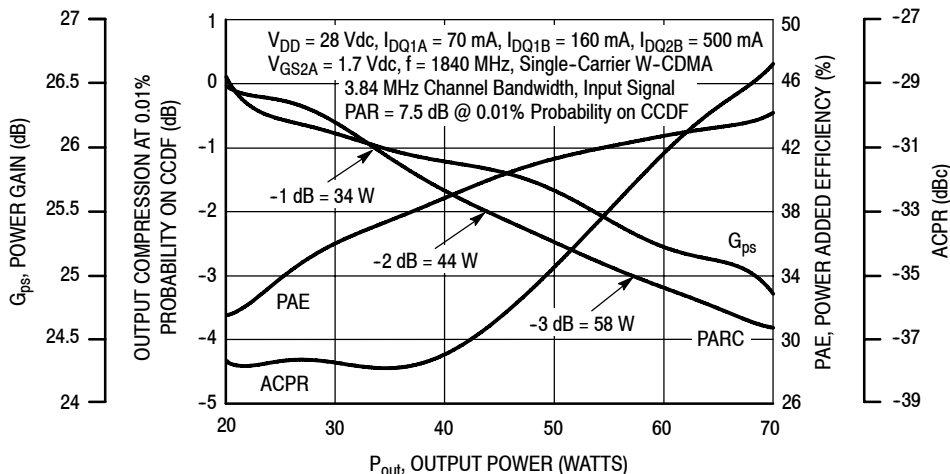

Figure 7. Output Peak-to-Average Ratio Compression (PARC) versus Output Power

TYPICAL CHARACTERISTICS

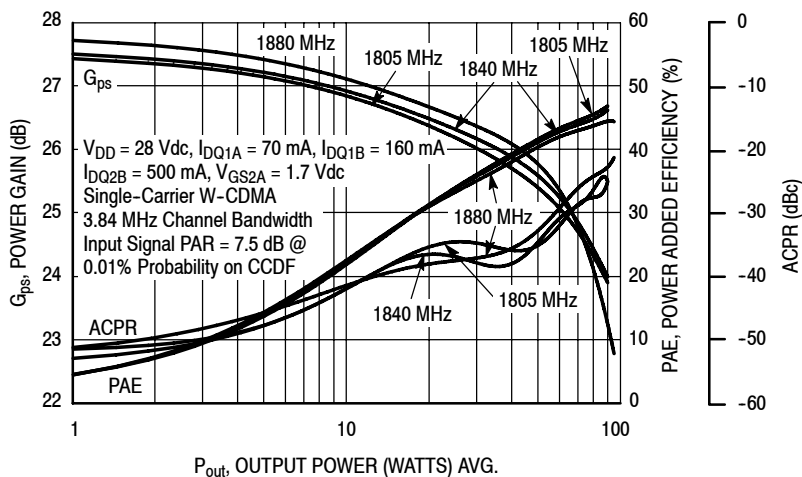

Figure 8. Single-Carrier W-CDMA Power Gain, Power Added Efficiency and ACPR versus Output Power

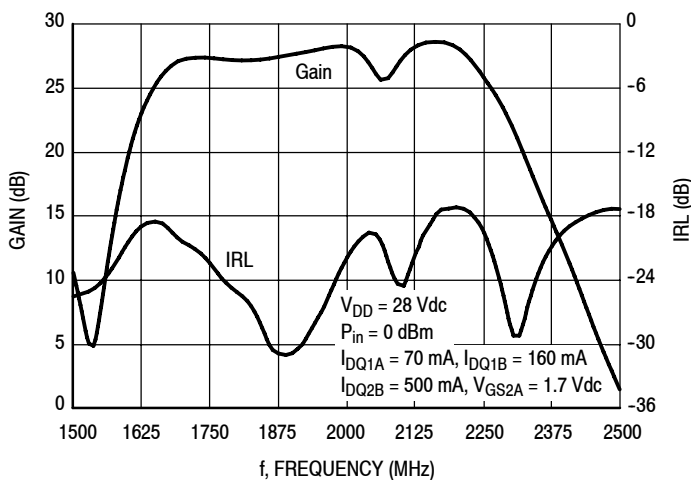

Figure 9. Broadband Frequency Response

W-CDMA TEST SIGNAL

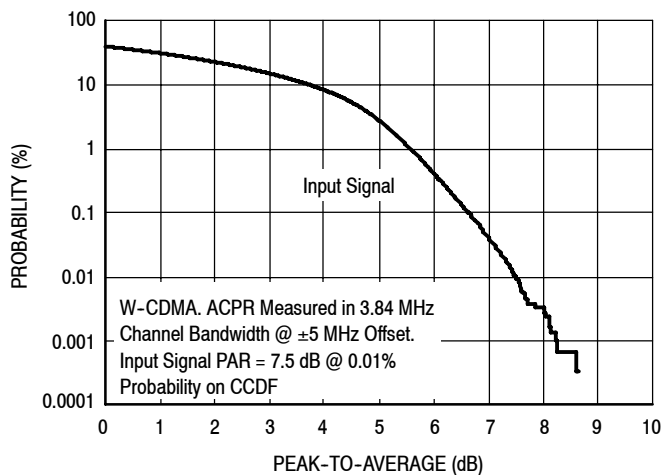

Figure 10. CCDF W-CDMA IQ Magnitude Clipping, Single-Carrier Test Signal

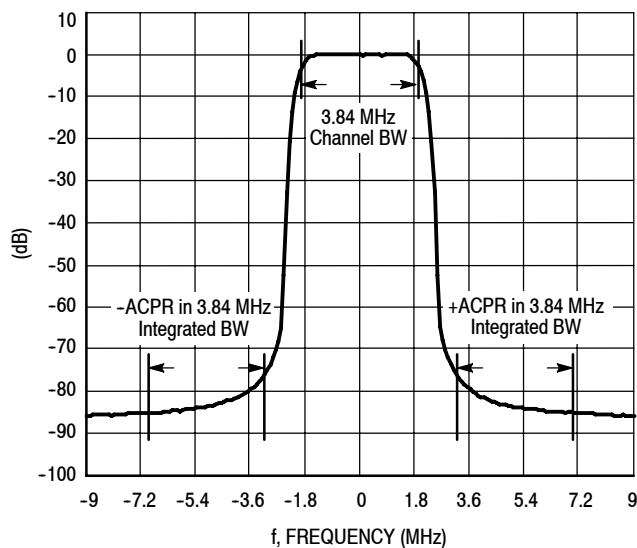

Figure 11. Single-Carrier W-CDMA Spectrum

$V_{DD} = 28 \text{ Vdc}$, $I_{DQ1B} = 120 \text{ mA}$, $I_{DQ2B} = 450 \text{ mA}$

f MHz	Max P _{out} (1)		Z _{in} Ω	Z _{load} Ω
	Watts	dBm		
1805	68	48.3	56.20 + j3.50	2.79 - j5.39
1840	69	48.4	60.80 - j6.10	2.81 - j5.45
1880	74	48.7	57.90 - j12.00	2.41 - j5.63

(1) Maximum output power measurement reflects pulsed 1 dB gain compression.

Z_{in} = Device input impedance as measured from gate to ground.

Z_{load} = Test circuit impedance as measured from drain to ground.

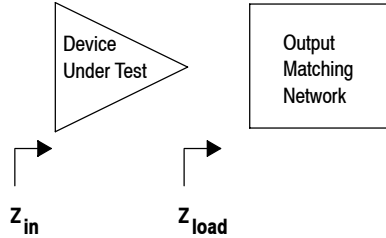

Figure 12. Maximum Output Power — Doherty Load Pull Optimization for Carrier Side

$V_{DD} = 28 \text{ Vdc}$, $I_{DQ1B} = 120 \text{ mA}$, $I_{DQ2B} = 450 \text{ mA}$

f MHz	Max Eff. (1) %	Z _{in} Ω	Z _{load} Ω
1840	53.4	60.80 - j6.10	3.74 - j4.54
1880	54.0	57.90 - j12.00	3.65 - j4.55

(1) Maximum efficiency measurement reflects pulsed 1 dB gain compression.

Z_{in} = Device input impedance as measured from gate to ground.

Z_{load} = Test circuit impedance as measured from drain to ground.

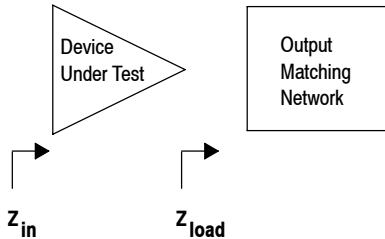
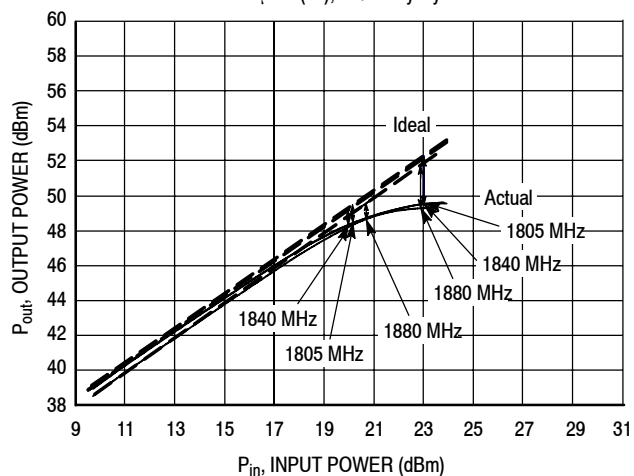

Figure 13. Maximum Efficiency — Doherty Load Pull Optimization for Carrier Side

ALTERNATIVE PEAK TUNE LOAD PULL CHARACTERISTICS

$V_{DD} = 28 \text{ Vdc}$, $I_{DQ1B} = 120 \text{ mA}$, $I_{DQ2B} = 450 \text{ mA}$, Pulsed CW,
 $10 \mu\text{sec}(\text{on})$, 10% Duty Cycle



NOTE: Load Pull Test Fixture Tuned for Peak P1dB Output Power @ 28 V

f (MHz)	P1dB		P3dB	
	Watts	dBm	Watts	dBm
1805	70	48.5	89	49.5
1840	69	48.4	89	49.5
1880	74	48.7	85	49.3

Test Impedances per Compression Level

f (MHz)		Z_{source} Ω	Z_{load} Ω
1805	P1dB	$56.20 - j3.50$	$2.80 - j5.40$
1840	P1dB	$60.80 + j6.10$	$2.80 - j5.40$
1880	P1dB	$57.90 + j12.00$	$2.40 - j5.60$

Figure 14. Pulsed CW Output Power versus Input Power @ 28 V

NOTE: Measurement made on the Class AB, carrier side of the device.

PACKAGE DIMENSIONS

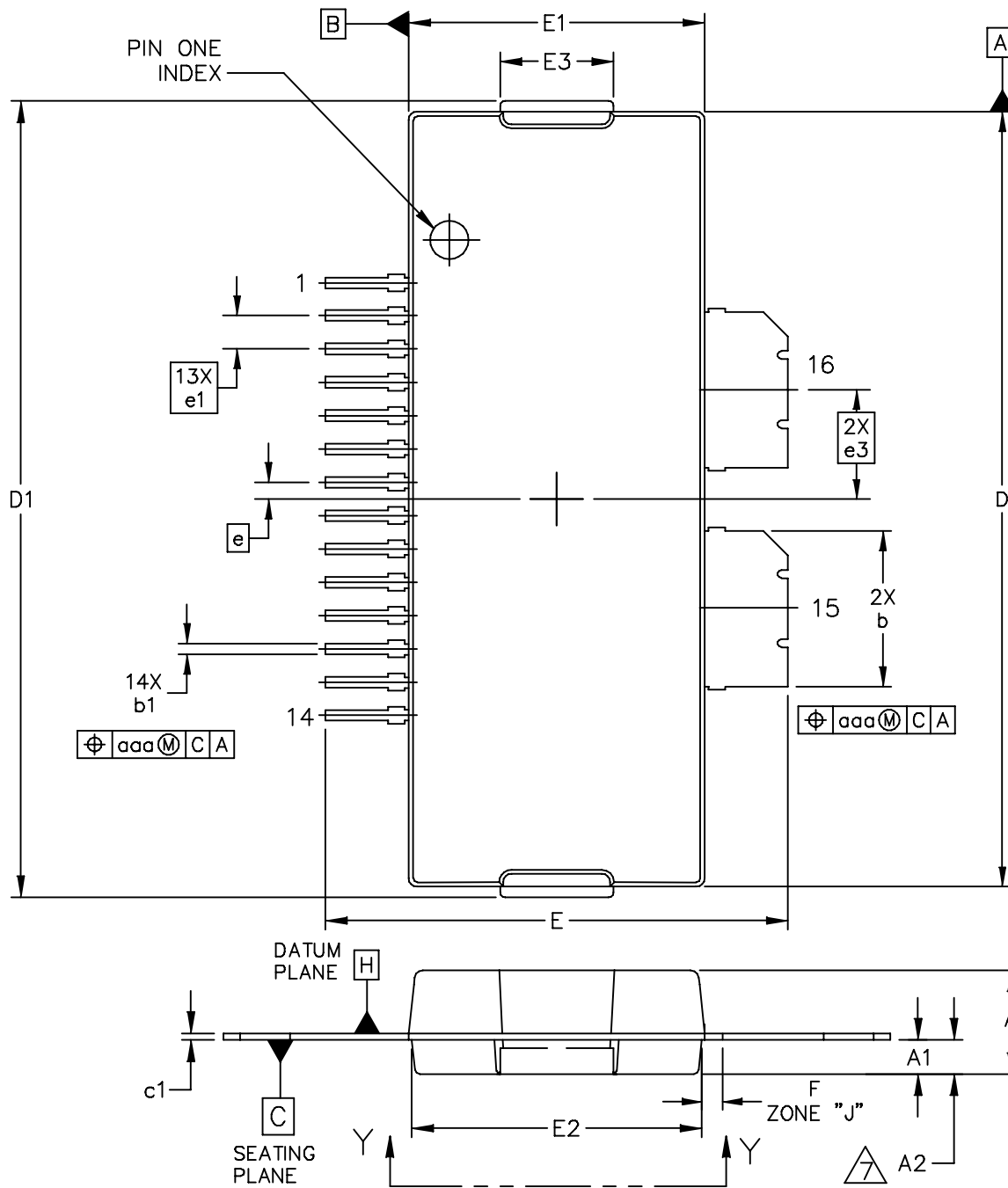

© FREESCALE SEMICONDUCTOR, INC. ALL RIGHTS RESERVED.	MECHANICAL OUTLINE	PRINT VERSION NOT TO SCALE	
TITLE: TO-270 WIDE BODY LONG, 16 LEAD, PLASTIC	DOCUMENT NO: 98ASA10739D	REV: A	
	CASE NUMBER: 1866-02	02 AUG 2007	
	STANDARD: NON-JEDEC		

MD7IC18120NR1 MD7IC18120GNR1

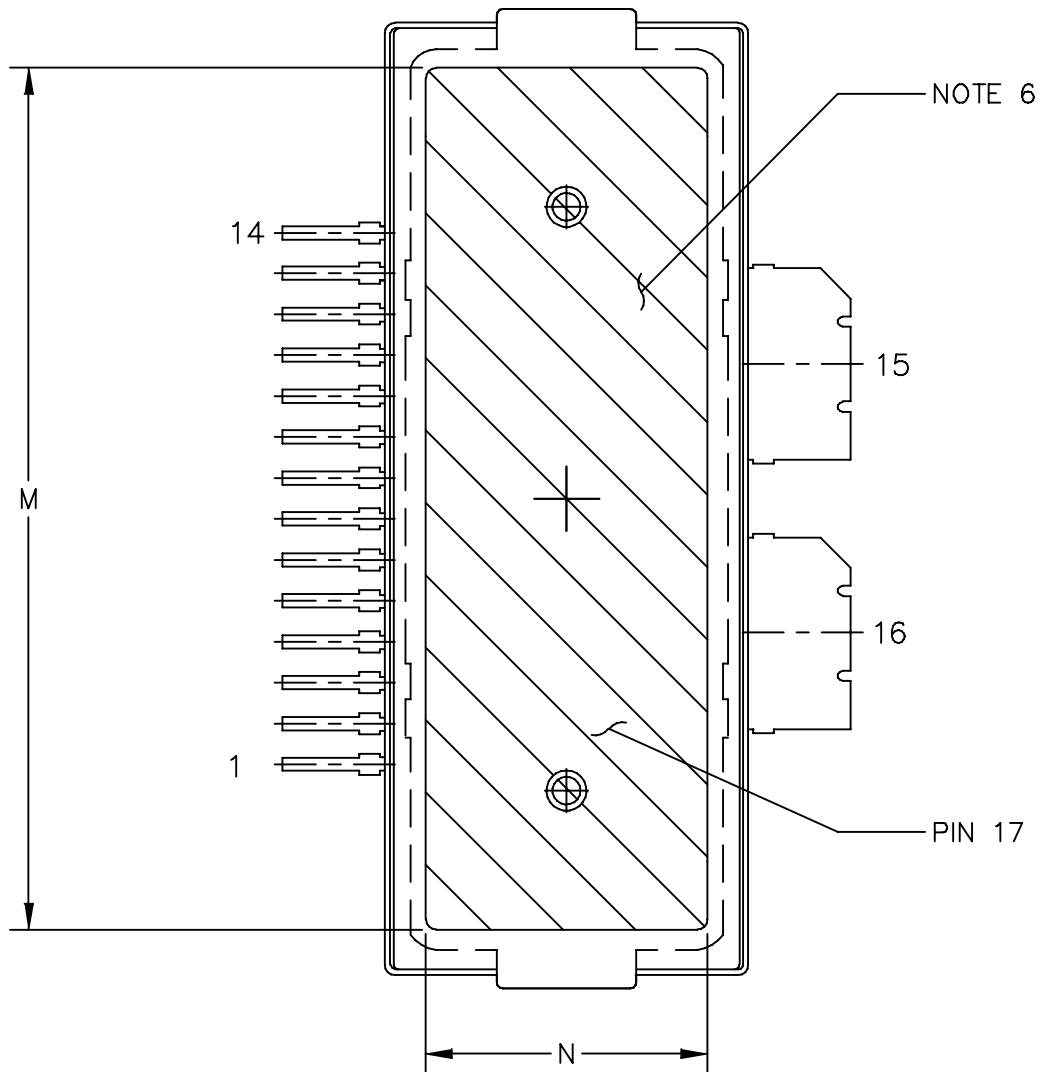

VIEW Y-Y

© FREESCALE SEMICONDUCTOR, INC. ALL RIGHTS RESERVED.	MECHANICAL OUTLINE	PRINT VERSION NOT TO SCALE	
TITLE: TO-270 WIDE BODY LONG, 16 LEAD, PLASTIC	DOCUMENT NO: 98ASA10739D	REV: A	
	CASE NUMBER: 1866-02	02 AUG 2007	
	STANDARD: NON-JEDEC		

NOTES:

1. CONTROLLING DIMENSION: INCH
2. INTERPRET DIMENSIONS AND TOLERANCES PER ASME Y14.5M-1994.
3. DATUM PLANE -H- IS LOCATED AT THE TOP OF LEAD AND IS COINCIDENT WITH THE LEAD WHERE THE LEAD EXITS THE PLASTIC BODY AT THE TOP OF THE PARTING LINE.
4. DIMENSIONS "D" AND "E1" DO NOT INCLUDE MOLD PROTRUSION. ALLOWABLE PROTRUSION IS .006 (0.15) PER SIDE. DIMENSIONS "D" AND "E1" DO INCLUDE MOLD MISMATCH AND ARE DETERMINED AT DATUM PLANE -H-.
5. DIMENSIONS "b" AND "b1" DO NOT INCLUDE DAMBAR PROTRUSION. ALLOWABLE DAMBAR PROTRUSION SHALL BE .005 (0.13) TOTAL IN EXCESS OF THE "b" AND "b1" DIMENSIONS AT MAXIMUM MATERIAL CONDITION.
6. HATCHING REPRESENTS THE EXPOSED AREA OF THE HEAT SLUG.
7. DIM A2 APPLIES WITHIN ZONE "J" ONLY.

DIM	INCH		MILLIMETER		DIM	INCH		MILLIMETER	
	MIN	MAX	MIN	MAX		MIN	MAX	MIN	MAX
A	.122	.128	3.10	3.25	M	.800	----	20.32	----
A1	.039	.043	0.96	1.12	N	.270	----	6.86	----
A2	.040	.042	1.02	1.07	b	.184	.190	4.67	4.83
D	.928	.932	23.57	23.67	b1	.010	.016	0.25	0.41
D1	.954	.958	24.23	24.33	c1	.007	.011	0.18	0.28
E	.551	.559	14.00	14.20	e	.020 BSC		0.51 BSC	
E1	.353	.357	8.97	9.07	e1	.040 BSC		1.02 BSC	
E2	.346	.350	8.79	8.89	e3	.131 BSC		3.33 BSC	
E3	.132	.140	3.35	3.56					
F	.025 BSC		0.64 BSC		aaa	.004		0.10	

© FREESCALE SEMICONDUCTOR, INC. ALL RIGHTS RESERVED.	MECHANICAL OUTLINE	PRINT VERSION NOT TO SCALE
TITLE: TO-270 WIDE BODY LONG, 16 LEAD, PLASTIC	DOCUMENT NO: 98ASA10739D	REV: A
	CASE NUMBER: 1866-02	02 AUG 2007
	STANDARD: NON-JEDEC	

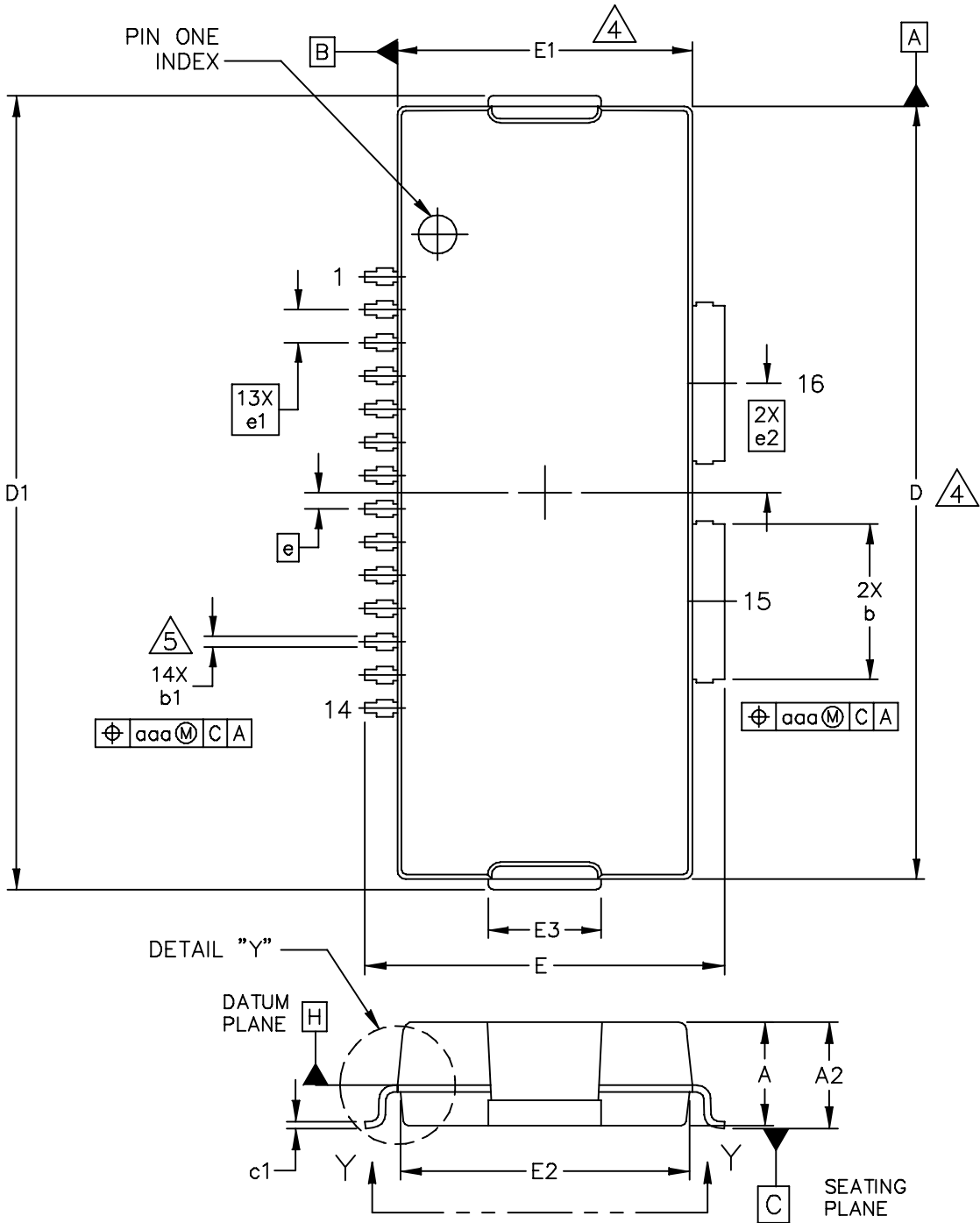

© FREESCALE SEMICONDUCTOR, INC. ALL RIGHTS RESERVED.	MECHANICAL OUTLINE	PRINT VERSION NOT TO SCALE	
TITLE: TO-270 WIDE BODY LONG, 16 LEAD, GULL WING PLASTIC	DOCUMENT NO: 98ASA10740D	REV: A	
	CASE NUMBER: 1867-02	02 AUG 2007	
	STANDARD: NON-JEDEC		

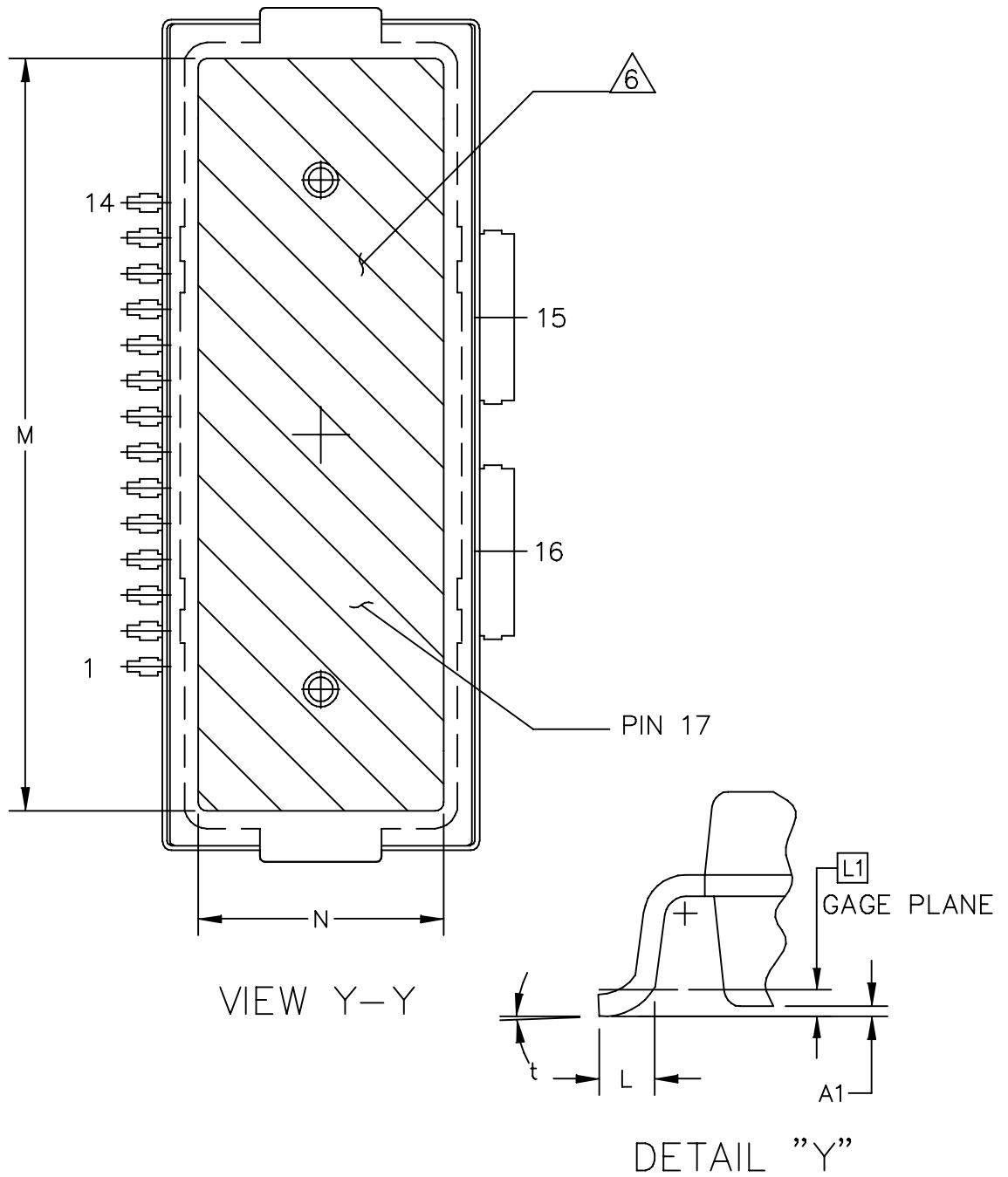

© FREESCALE SEMICONDUCTOR, INC. ALL RIGHTS RESERVED.	MECHANICAL OUTLINE	PRINT VERSION NOT TO SCALE	
TITLE: TO-270 WIDE BODY LONG, 16 LEAD, GULL WING PLASTIC	DOCUMENT NO: 98ASA10740D	REV: A	
	CASE NUMBER: 1867-02	02 AUG 2007	
	STANDARD: NON-JEDEC		

MD7IC18120NR1 MD7IC18120GNR1

NOTES:

1. CONTROLLING DIMENSION: INCH
2. INTERPRET DIMENSIONS AND TOLERANCES PER ASME Y14.5M-1994.
3. DATUM PLANE H IS LOCATED AT THE TOP OF LEAD AND IS COINCIDENT WITH THE LEAD WHERE THE LEAD EXITS THE PLASTIC BODY AT THE TOP OF THE PARTING LINE.
4. DIMENSIONS DO NOT INCLUDE MOLD PROTRUSION. ALLOWABLE PROTRUSION IS .006 PER SIDE. DIMENSIONS DO INCLUDE MOLD MISMATCH AND ARE DETERMINED AT DATUM PLANE H.
5. DIMENSION DOES NOT INCLUDE DAMBAR PROTRUSION. ALLOWABLE DAMBAR PROTRUSION SHALL BE .005 TOTAL IN EXCESS OF THE DIMENSION AT MAXIMUM MATERIAL CONDITION.
6. HATCHING REPRESENTS THE EXPOSED AREA OF THE HEAT SLUG.

DIM	INCH		MILLIMETER		DIM	INCH		MILLIMETER	
	MIN	MAX	MIN	MAX		MIN	MAX	MIN	MAX
A	.122	.128	3.10	3.25	b	.184	.190	4.67	4.83
A1	.001	.004	0.02	0.10	b1	.010	.016	0.25	0.41
A2	.125	.131	3.18	3.33	c1	.007	.011	0.18	0.28
D	.928	.932	23.57	23.67	e	.020 BSC		0.51 BSC	
D1	.954	.958	24.23	24.33	e1	.040 BSC		1.02 BSC	
E	.429	.437	10.9	11.1	e2	.131 BSC		3.33 BSC	
E1	.353	.357	8.97	9.07	t	2°	8°	2°	8°
E2	.346	.350	8.79	8.89	aaa	.004		0.10	
E3	.132	.140	3.35	3.56					
L	.018	.024	0.46	0.61					
L1	.01 BSC		0.25 BSC						
M	.800	----	20.32	----					
N	.270	----	6.86	----					
© FREESCALE SEMICONDUCTOR, INC. ALL RIGHTS RESERVED.			MECHANICAL OUTLINE			PRINT VERSION NOT TO SCALE			
TITLE: TO-270 WIDE BODY LONG, 16 LEAD, GULL WING PLASTIC					DOCUMENT NO: 98ASA10740D			REV: A	
					CASE NUMBER: 1867-02			02 AUG 2007	
					STANDARD: NON-JEDEC				

PRODUCT DOCUMENTATION AND SOFTWARE

Refer to the following documents, tools and software to aid your design process.

Application Notes

- AN1955: Thermal Measurement Methodology of RF Power Amplifiers
- AN1977: Quiescent Current Thermal Tracking Circuit in the RF Integrated Circuit Family
- AN1987: Quiescent Current Control for the RF Integrated Circuit Device Family

Engineering Bulletins

- EB212: Using Data Sheet Impedances for RF LDMOS Devices

Software

- Electromigration MTTF Calculator
- RF High Power Model
- .s2p File

For Software, do a Part Number search at <http://www.freescale.com>, and select the “Part Number” link. Go to the Software & Tools tab on the part’s Product Summary page to download the respective tool.

REVISION HISTORY

The following table summarizes revisions to this document.

Revision	Date	Description
0	May 2010	• Initial Release of Data Sheet

How to Reach Us:

Home Page:

www.freescale.com

Web Support:

<http://www.freescale.com/support>

USA/Europe or Locations Not Listed:

Freescale Semiconductor, Inc.
Technical Information Center, EL516
2100 East Elliot Road
Tempe, Arizona 85284
1-800-521-6274 or +1-480-768-2130
www.freescale.com/support

Europe, Middle East, and Africa:

Freescale Halbleiter Deutschland GmbH
Technical Information Center
Schatzbogen 7
81829 Muenchen, Germany
+44 1296 380 456 (English)
+46 8 52200080 (English)
+49 89 92103 559 (German)
+33 1 69 35 48 48 (French)
www.freescale.com/support

Japan:

Freescale Semiconductor Japan Ltd.
Headquarters
ARCO Tower 15F
1-8-1, Shimo-Meguro, Meguro-ku,
Tokyo 153-0064
Japan
0120 191014 or +81 3 5437 9125
support.japan@freescale.com

Asia/Pacific:

Freescale Semiconductor China Ltd.
Exchange Building 23F
No. 118 Jianguo Road
Chaoyang District
Beijing 100022
China
+86 10 5879 8000
support.asia@freescale.com

For Literature Requests Only:

Freescale Semiconductor Literature Distribution Center
1-800-441-2447 or +1-303-675-2140
Fax: +1-303-675-2150
LDCForFreescaleSemiconductor@hibbertgroup.com

Information in this document is provided solely to enable system and software implementers to use Freescale Semiconductor products. There are no express or implied copyright licenses granted hereunder to design or fabricate any integrated circuits or integrated circuits based on the information in this document.

Freescale Semiconductor reserves the right to make changes without further notice to any products herein. Freescale Semiconductor makes no warranty, representation or guarantee regarding the suitability of its products for any particular purpose, nor does Freescale Semiconductor assume any liability arising out of the application or use of any product or circuit, and specifically disclaims any and all liability, including without limitation consequential or incidental damages. "Typical" parameters that may be provided in Freescale Semiconductor data sheets and/or specifications can and do vary in different applications and actual performance may vary over time. All operating parameters, including "Typicals", must be validated for each customer application by customer's technical experts. Freescale Semiconductor does not convey any license under its patent rights nor the rights of others. Freescale Semiconductor products are not designed, intended, or authorized for use as components in systems intended for surgical implant into the body, or other applications intended to support or sustain life, or for any other application in which the failure of the Freescale Semiconductor product could create a situation where personal injury or death may occur. Should Buyer purchase or use Freescale Semiconductor products for any such unintended or unauthorized application, Buyer shall indemnify and hold Freescale Semiconductor and its officers, employees, subsidiaries, affiliates, and distributors harmless against all claims, costs, damages, and expenses, and reasonable attorney fees arising out of, directly or indirectly, any claim of personal injury or death associated with such unintended or unauthorized use, even if such claim alleges that Freescale Semiconductor was negligent regarding the design or manufacture of the part.

Freescale™ and the Freescale logo are trademarks of Freescale Semiconductor, Inc. All other product or service names are the property of their respective owners.

© Freescale Semiconductor, Inc. 2010. All rights reserved.



Looking for pricing, stock, or lifecycle information?

Click below to explore more details on WIN SOURCE:

- ⊖ [View MD7IC18120NR1 on WIN SOURCE](#)
- ⊖ [Freescale Semiconductor - NXP Information](#)

Optimize Your Supply Chain with WIN SOURCE Solutions

- ✓ Global Sourcing Solution
- ✓ Obsolete Management
- ✓ Cost Control Management
- ✓ Shortage Management
- ✓ Alternative Solution
- ✓ Excess Inventory Management