

Device Features

- +5V/550mA at operating bias condition
- Gain = 27.4 dB @ 2350 MHz
- P1dB = 34.1 dBm @ 2350 MHz
- LTE 10M ACLR = 23.5dBm Output Power at -50dBc @ 2350 MHz
- Intergrated interstage matching
- Green/RoHS2-compliant QFN5x5 SMT package



Product Description

The BMT333 is a high dynamic range two-stage power amplifier housed in a green/RoHS2 compliant 5x5mm QFN package. The BMT333 uses a high reliability InGaP/GaAs HBT process technology. The BMT333 is designed for use where high linearity and gain are required. The BMT333 is able to deliver over 22 dBm output power from 1.8 to 2.7GHz while maintaining superior ACLR performance with a few external matching components. All devices are 100% RF/DC screened.

Applications

- Base station/Repeaters Infrastructure/Small Cell
- Commercial/Industrial/Military wireless system
- LTE / WCDMA /CDMA Wireless Infrastructure
- Wireless LAN

Application Circuits

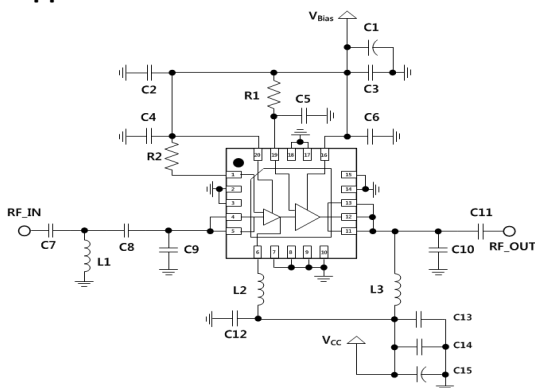

*External matching circuit: refer to the page 5 to 14.

Electrical Specifications

Device performance _ measured on a BeRex evaluation board at 25°C, Vc=5V, 50 Ω system.

Parameter	Conditions	Min	Typ	Max	Unit
Operational Frequency Range		1800		2700	MHz
Test Frequency			2350		MHz
Gain		25.9	27.4		dB
Input Return Loss			-25.8		dB
Output Return Loss			-19.8		dB
Output IP3	23 dBm/tone, Δf=1 MHz	47.0	50.0		dBm
Output P1dB		33.1	34.1		dBm
LTE 10M ACLR*		22.5	23.5		dBm
WCDMA ACLR*		23.4	24.4		dBm
Noise Figure			5.3		dB

*ACLR Channel Power measured at -50dBc.

- LTE set-up: 3GPP LTE, FDD E-TM3.1, 10MHz BW, ±5MHz offset, PAR 9.75 @0.01% Prob.

- WCDMA set-up: 3GPP WCDMA, TM1+64DPCH, +5MHz offset, PAR 9.78 at 0.01% Prob.

Recommended Operating Conditions

Parameter	Min	Typ	Max	Unit
Bandwidth	1800		2700	MHz
I _{bias} @ (I _{REF1&2} + I _{B1&2})	22	27	32	mA
I _C @ (I _{C1} + I _{C2})	440	550	660	mA
V _{CC} /V _{bias}	4.5	5.0	5.25	V
R _{TH}		8.7		°C/W
Operating Case Temperature	-40		+85	°C

Electrical specifications are measured at specified test conditions.

Specifications are not guaranteed over all recommended operating conditions.

Absolute Maximum Ratings

Parameter	Rating	Unit
Storage Temperature	-55 to +155	°C
Junction Temperature	+175	°C
Supply Voltage	+6	V
Supply Current	2	A
Input RF Power	20	dBm

*Operation of this device above any of these parameters may result in permanent damage.

Typical Performance (V_{cc} & V_{Bias} = +5V, I_{cq} =550mA, T_a =25°C)

Parameter	Frequency				Unit
	1800	2350	2550	2650	MHz
Gain	29.7	27.4	26.2	25.5	dB
S11	-23.4	-25.8	-23.1	-19.3	dB
S22	-12.4	-19.8	-17.0	-18.7	dB
OIP3	45.1	50.0	48.3	48.2	dBm
P1dB	32.9	34.1	33.3	33.5	dBm
LTE 10M ACLR	22.0	23.5	23.0	22.7	dBm
WCDMA ACLR	22.9	24.4	23.9	23.7	dBm
Noise Figure	5.9	5.3	5.0	5.1	dB

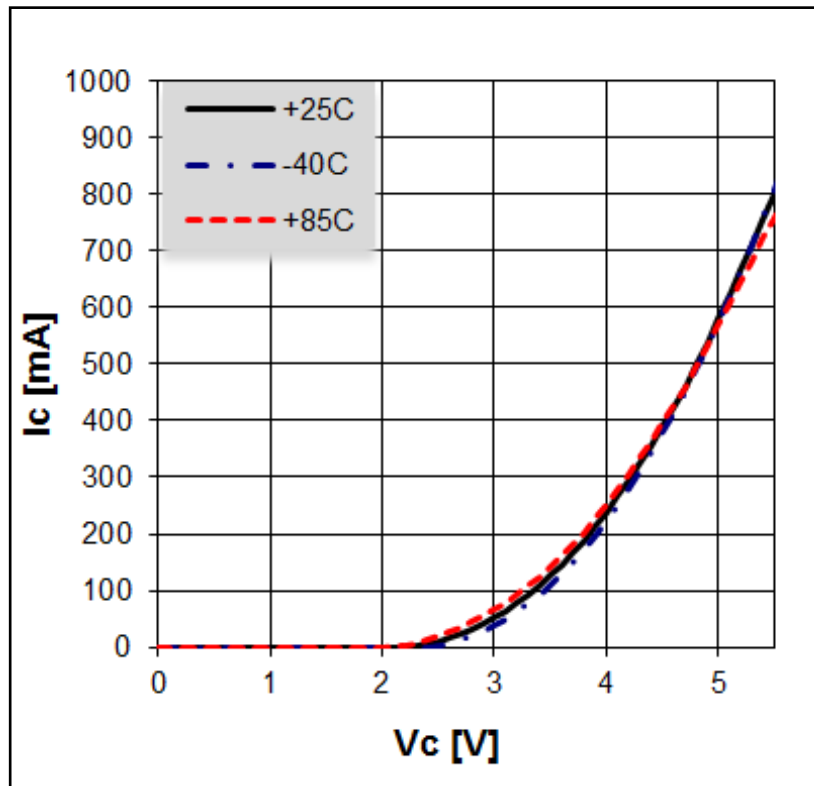
V-I Characteristics

Pin Configuration

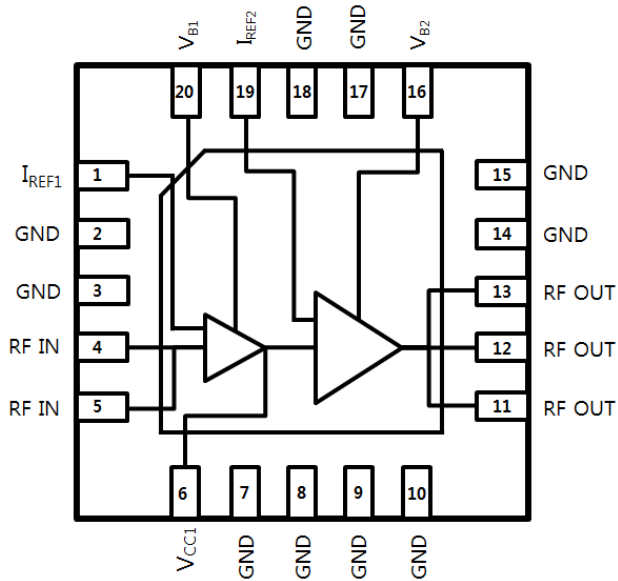

Pin No.	Label
1	I_{REF1}
4,5	RF IN
6	V_{CC1}
11,12,13	RF OUT/ V_{CC2}
16	V_{B2}
19	I_{REF2}
20	V_{B1}
2,3,7,8,9,10,14, 15,17,18	GND
Backside Paddle	GND

BeRex Evaluation Board

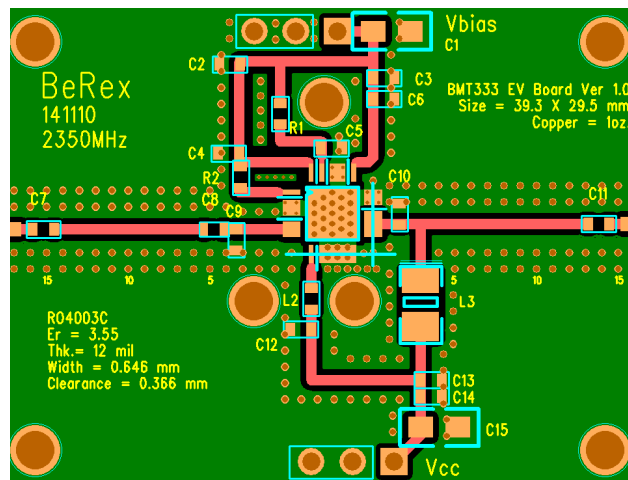
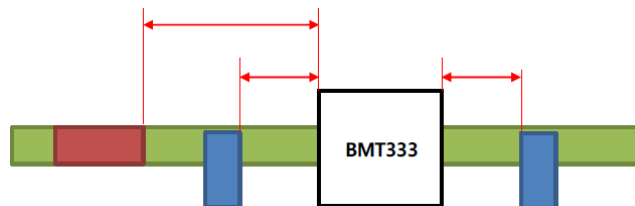
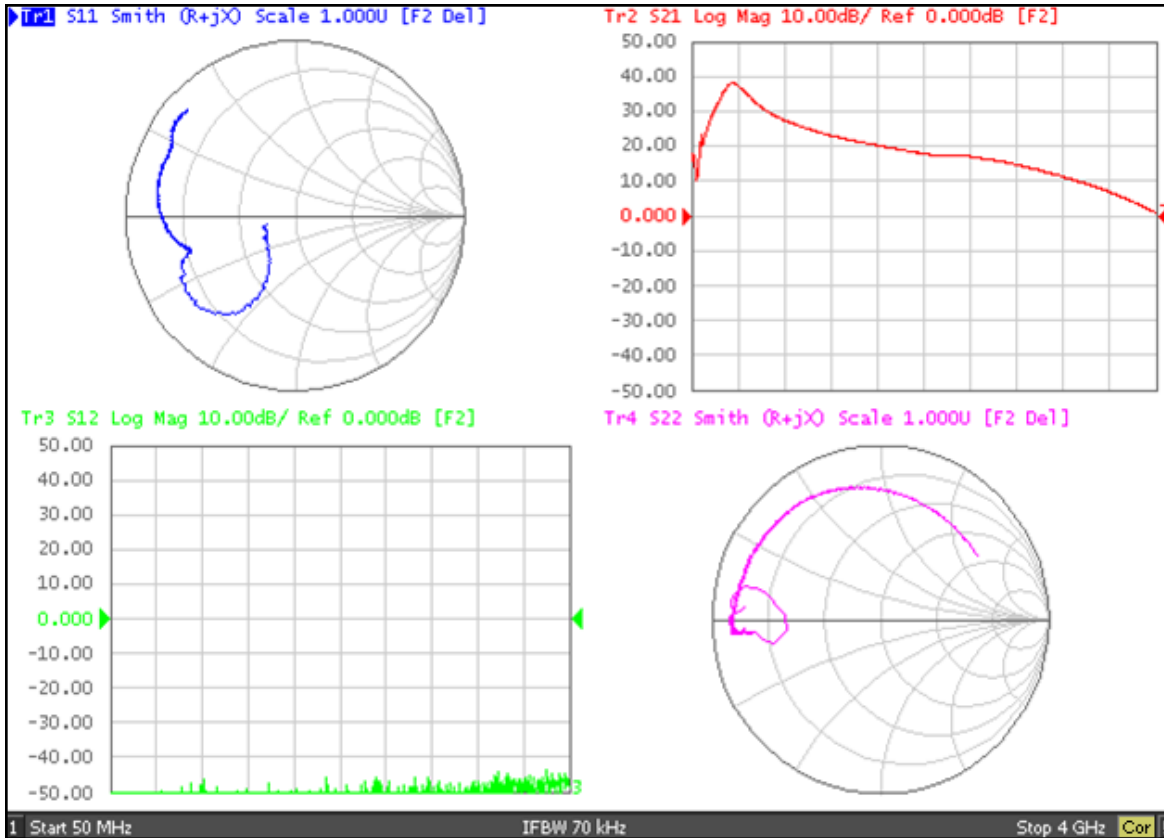

Figure about the reference position of components



Typical Device Data

S-parameters (V_{cc} & V_{Bias} = +5V, I_{cq} =550mA, T_a =25°C)



S-Parameter

(V_{cc} & V_{Bias} = +5V, I_{cq} = 550mA, T_a = 25 °C, calibrated to device leads)

Freq [MHz]	S11 [Mag]	S11 [Ang]	S21 [Mag]	S21 [Ang]	S12 [Mag]	S12 [Ang]	S22 [Mag]	S22 [Ang]
1800	0.823	48.909	8.999	-14.544	0.002	-47.886	0.851	56.153
1900	0.829	39.208	8.410	-31.779	0.003	-54.191	0.851	47.807
2000	0.829	29.005	7.873	-48.880	0.002	-46.186	0.855	39.252
2100	0.837	19.120	7.499	-65.053	0.001	-44.098	0.846	30.329
2200	0.840	9.645	7.353	-81.298	0.002	-103.445	0.846	21.294
2300	0.839	0.350	7.422	-101.020	0.004	-80.766	0.843	12.643
2400	0.834	-8.866	7.175	-122.701	0.003	-106.587	0.839	3.550
2500	0.834	-17.528	6.794	-143.783	0.003	-39.239	0.838	-5.571
2600	0.834	-26.175	6.401	-164.426	0.002	-150.204	0.833	-15.217
2700	0.833	-34.246	5.948	174.823	0.002	-71.305	0.832	-25.071

Application Circuit: 1800 MHz

Preliminary Datasheet

Schematic Diagram		BOM		Marks
	C1	1206	10uF	Tantalum
	C2	0603	N/A	
	C3	0603	680pF	COG/NPO
	C4	0603	1nF	
	C5	0603	1nF	
	C6	0603	N/A	
	C7	0603	0 Ω	Jumper
	C8	0603	2.5pF	
	C9	0603	N/A	
	C10	0603	4.3pF	High Q Cap
	C11	0603	3.9pF	
	C12	0603	1uF	
	C13	0603	100pF	
	C14	0603	1nF	
	C15	1206	10uF	Tantalum
L1	0603	2.2nH		
L2	0603	39nH		
L3	1008	39nH	High Q Coil	
R1	0603	150 Ω	±5%	
R2	0603	270 Ω	±5%	

PCB Diagram	Notice																					
	Below information is subject to change as conditions of the substrate.																					
	<table border="1"> <thead> <tr> <th>Reference</th> <th>Object</th> <th>Distance</th> </tr> </thead> <tbody> <tr> <td>Input pin</td> <td>L1</td> <td>1.4mm</td> </tr> <tr> <td>Input pin</td> <td>C8</td> <td>3.4mm</td> </tr> <tr> <td>Output pin</td> <td>C10</td> <td>2.6mm</td> </tr> <tr> <td>Pin 16</td> <td>C3</td> <td>6.0mm</td> </tr> <tr> <td>Pin 19</td> <td>C5</td> <td>1.0mm</td> </tr> <tr> <td>Pin 20</td> <td>C4</td> <td>5.0mm</td> </tr> </tbody> </table>	Reference	Object	Distance	Input pin	L1	1.4mm	Input pin	C8	3.4mm	Output pin	C10	2.6mm	Pin 16	C3	6.0mm	Pin 19	C5	1.0mm	Pin 20	C4	5.0mm
	Reference	Object	Distance																			
	Input pin	L1	1.4mm																			
	Input pin	C8	3.4mm																			
	Output pin	C10	2.6mm																			
	Pin 16	C3	6.0mm																			
Pin 19	C5	1.0mm																				
Pin 20	C4	5.0mm																				
<p>1. Pin 16 & 20 is used for Vce of the inner bias circuit. To eliminate bias line resonance you need above 10mm transmission line and adjust the position of C2, C3, C4, C5 and C6. Also you can adjust spectrum regrowth about bandwidth of signals which you want.</p>																						
<p>2. C10 : We recommend High-Q capacitor for better output power performance. In this document we used 4.3pF(251R14S4R3BV4, EIA 0603) of Johanson Technology.</p>																						
<p>3. C7 are just jumpers as 0Ω</p>																						

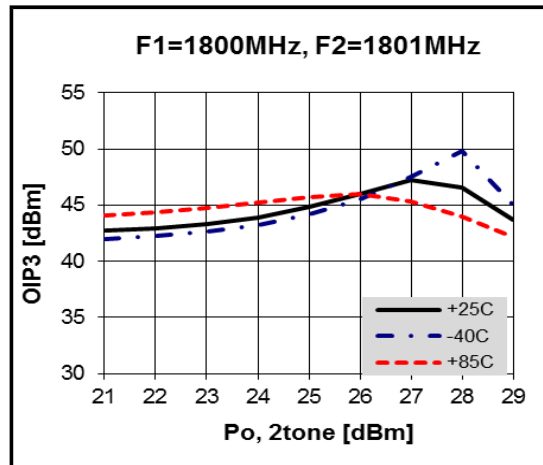
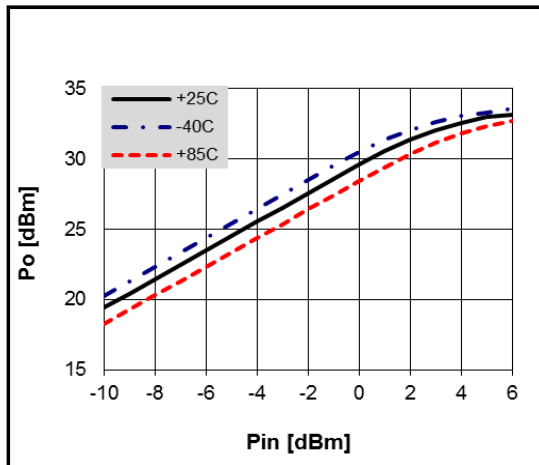
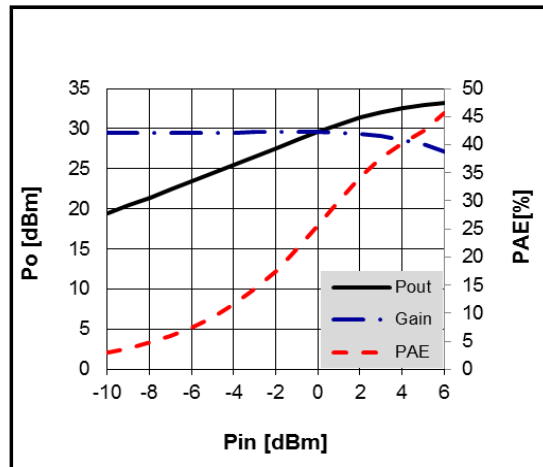
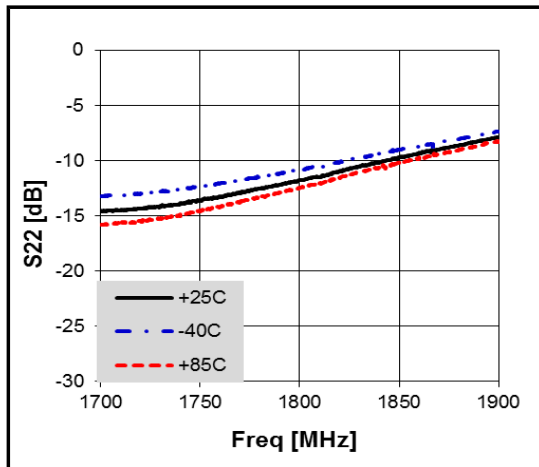
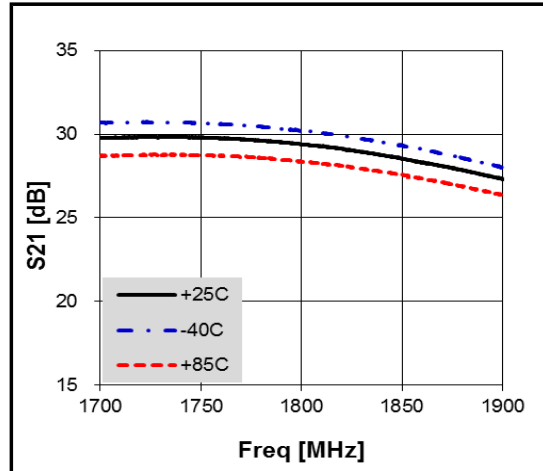
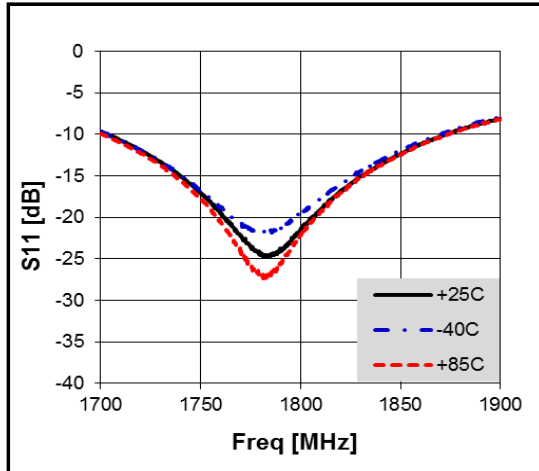
1800-2700 MHz 2W High Linearity 5V 2-Stage Power Amplifier
Typical Performance
 $(V_{CC} \ \& \ V_{Bias} = +5V, I_{CQ} = 550mA, T_a = 25 \text{ }^\circ\text{C})$

1800-2700 MHz 2W High Linearity 5V 2-Stage Power Amplifier

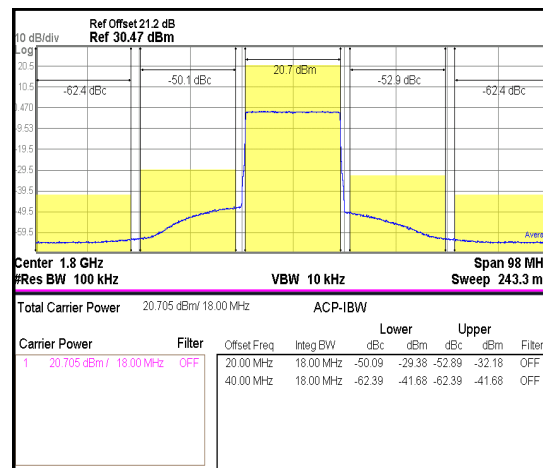
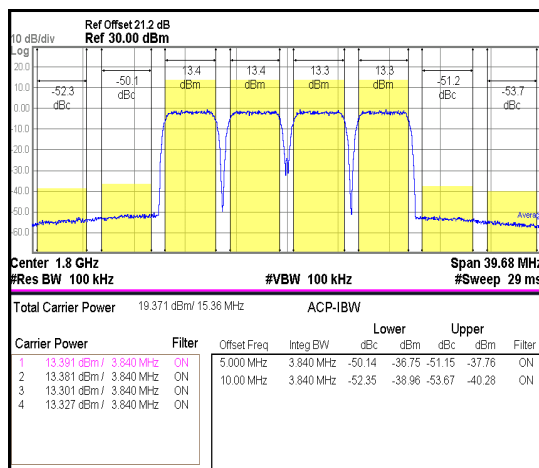
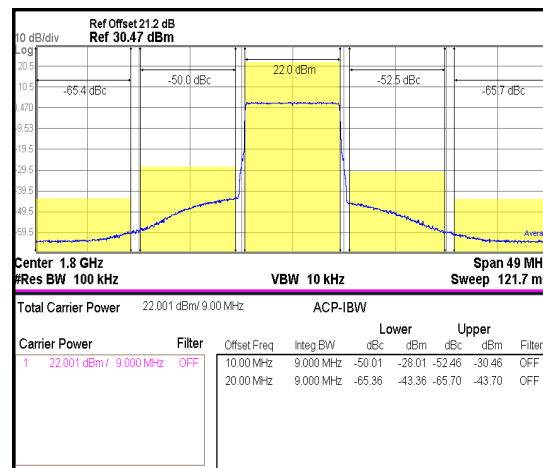
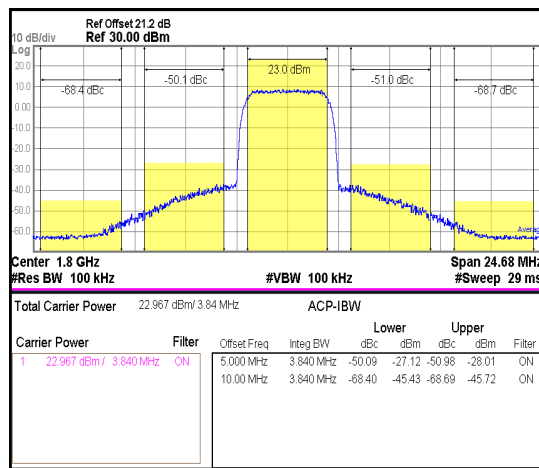
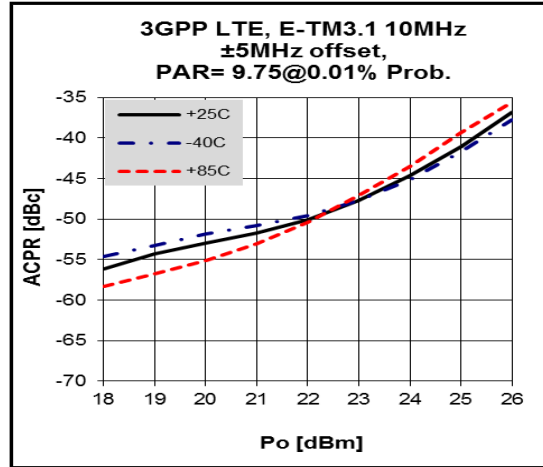
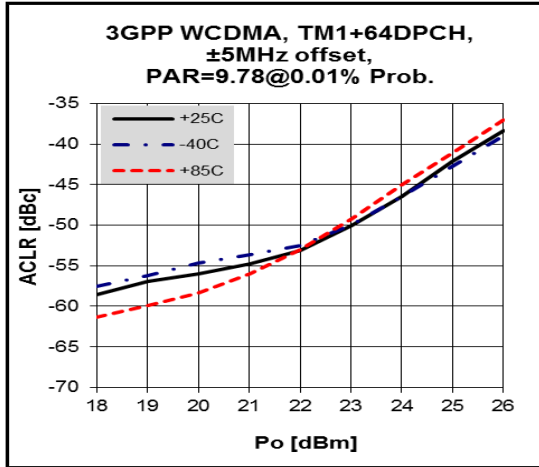

Application Circuit: 2350 MHz

Schematic Diagram	BOM		Marks	
	C1	1206 10uF	Tantalum	
	C2	0603	N/A	
	C3	0603	680pF	COG/NPO
	C4	0603	1nF	
	C5	0603	1nF	
	C6	0603	27pF	COG/NPO
	C7	0603	0 Ω	Jumper
	C8	0603	1.2pF	
	C9	0603	1.2pF	
	C10	0603	3.3pF	High Q Cap
	C11	0603	10pF	
	C12	0603	1nF	
	C13	0603	100pF	
	C14	0603	1nF	
	C15	1206	10uF	Tantalum
L1	0603	N/A		
L2	0603	0 Ω	Jumper	
L3	1008	18nH	High Q Coil	
R1	0603	150 Ω	±5%	
R2	0603	270 Ω	±5%	

PCB Diagram	Notice																								
	<p>Below information is subject to change as conditions of the substrate.</p> <table border="1"> <thead> <tr> <th>Reference</th> <th>Object</th> <th>Distance</th> </tr> </thead> <tbody> <tr> <td>Input pin</td> <td>C8</td> <td>4.0mm</td> </tr> <tr> <td>Input pin</td> <td>C9</td> <td>3.0mm</td> </tr> <tr> <td>Output pin</td> <td>C10</td> <td>1.2mm</td> </tr> <tr> <td>Pin 16</td> <td>C3</td> <td>6.2mm</td> </tr> <tr> <td>Pin 16</td> <td>C6</td> <td>5.0mm</td> </tr> <tr> <td>Pin 19</td> <td>C5</td> <td>1.0mm</td> </tr> <tr> <td>Pin 20</td> <td>C4</td> <td>5.0mm</td> </tr> </tbody> </table> <p>1. Pin 16 & 20 is used for Vce of the inner bias circuit. To eliminate bias line resonance you need above 10mm transmission line and adjust the position of C2, C3, C4, C5 and C6. Also you can adjust spectrum regrowth about bandwidth of signals which you want.</p> <p>2. C10 : We recommend High-Q capacitor for better output power performance. In this document we used 3.3pF(251R1453R3BV4, EIA 0603) of Johanson Technology.</p> <p>3. C7 & L2 are just jumpers as 0Ω</p>	Reference	Object	Distance	Input pin	C8	4.0mm	Input pin	C9	3.0mm	Output pin	C10	1.2mm	Pin 16	C3	6.2mm	Pin 16	C6	5.0mm	Pin 19	C5	1.0mm	Pin 20	C4	5.0mm
	Reference	Object	Distance																						
Input pin	C8	4.0mm																							
Input pin	C9	3.0mm																							
Output pin	C10	1.2mm																							
Pin 16	C3	6.2mm																							
Pin 16	C6	5.0mm																							
Pin 19	C5	1.0mm																							
Pin 20	C4	5.0mm																							

Typical Performance

(V_{CC} & $V_{Bias} = +5V$, $I_{CQ} = 550mA$, $T_a = 25\text{ }^\circ C$)

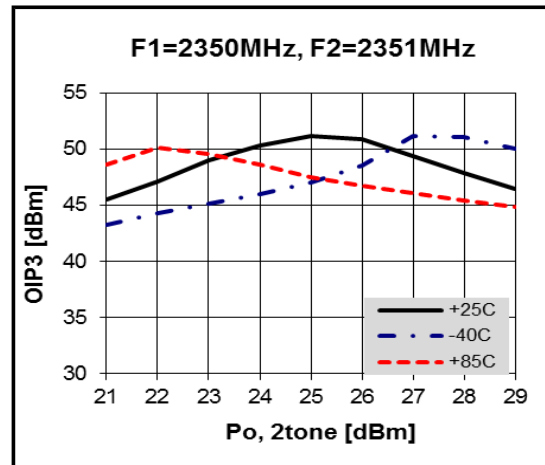
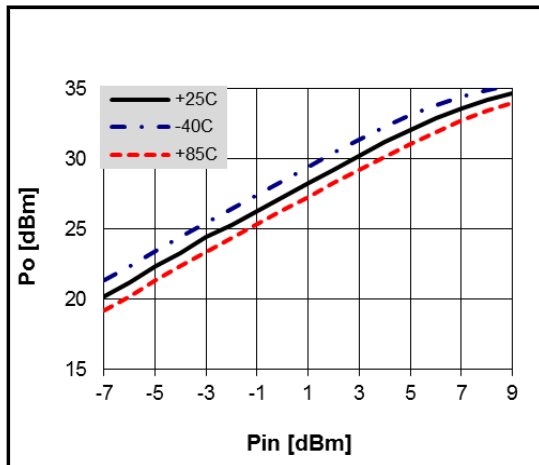
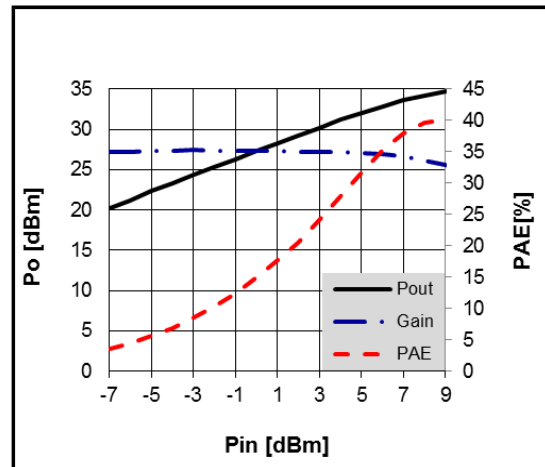
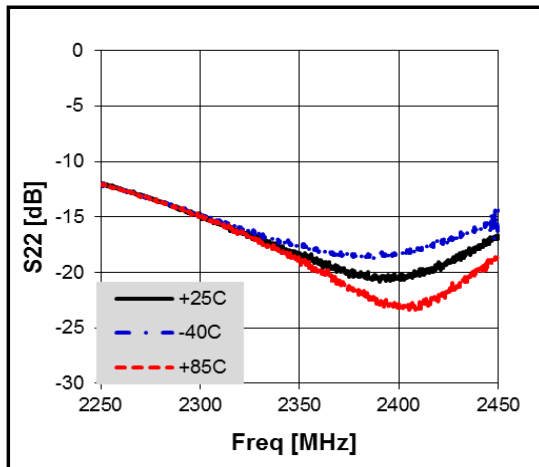
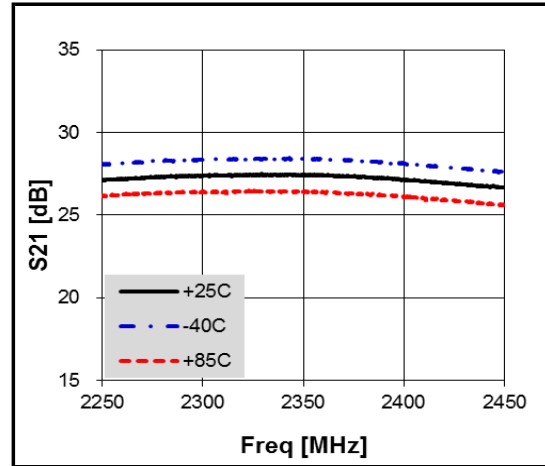
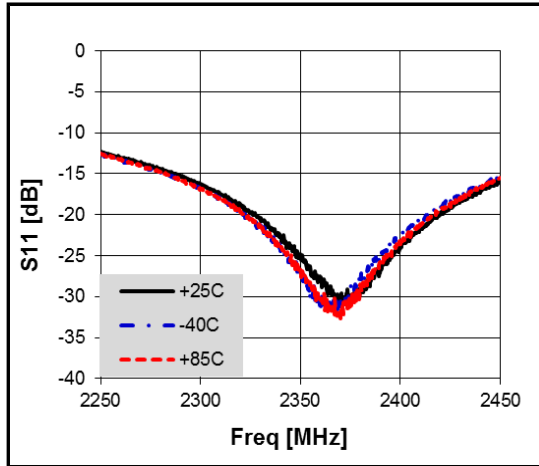

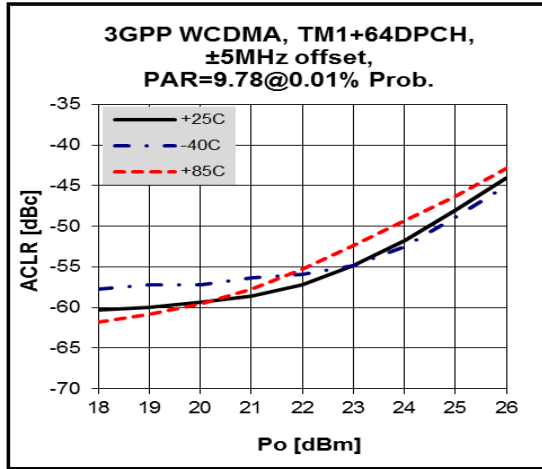
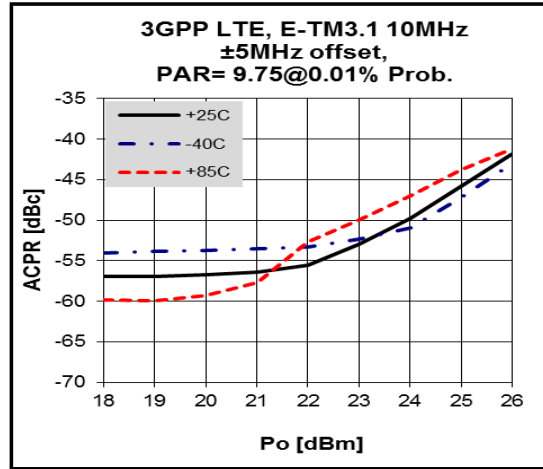
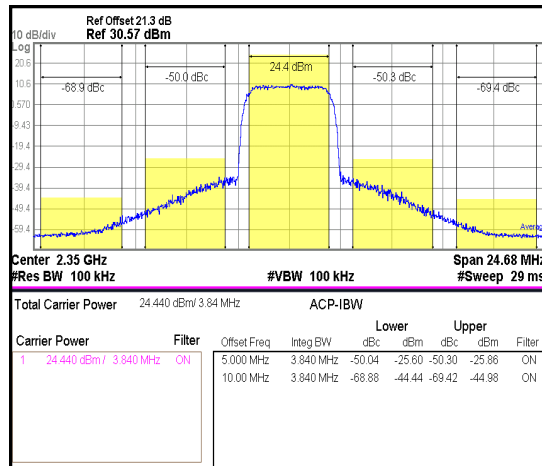
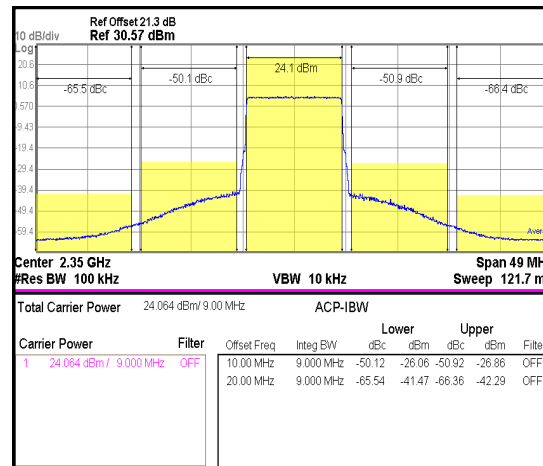
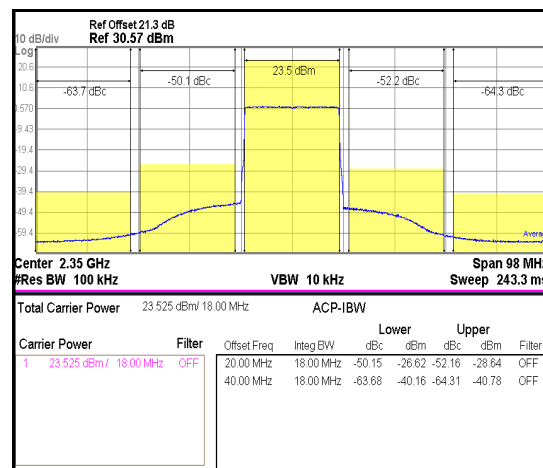
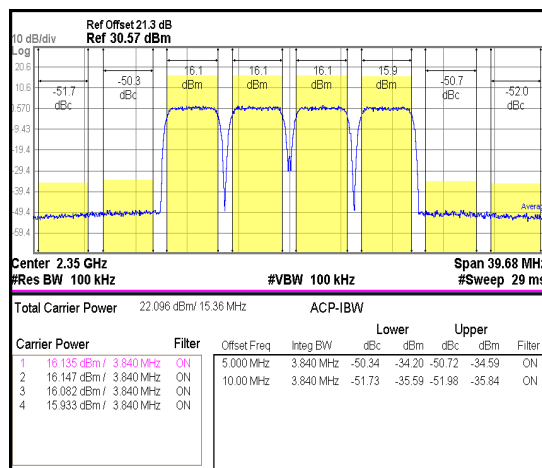
1800-2700 MHz 2W High Linearity 5V 2-Stage Power Amplifier

3GPP WCDMA TM1 +64DPCH 1FA

3GPP LTE E-TM3.1 10MHz

3GPP WCDMA TM1 +64DPCH 4FA

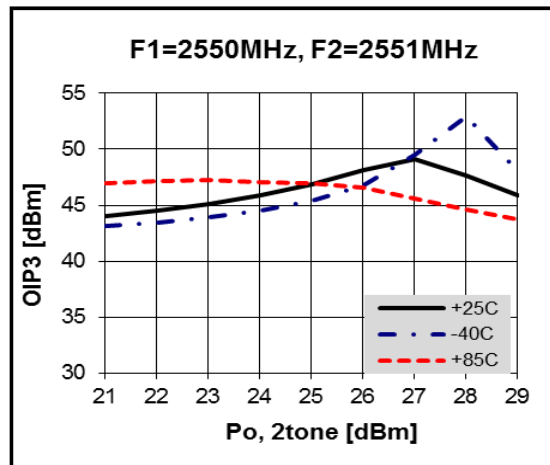
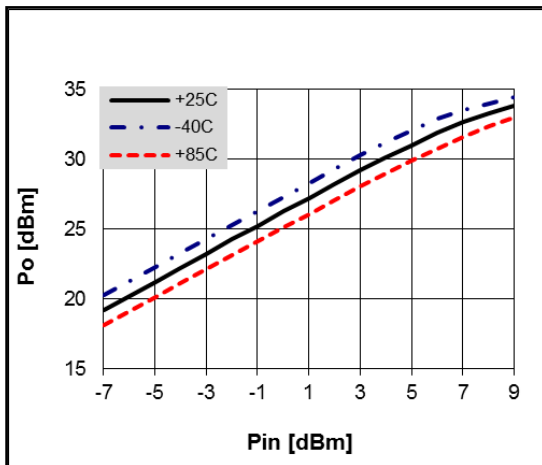
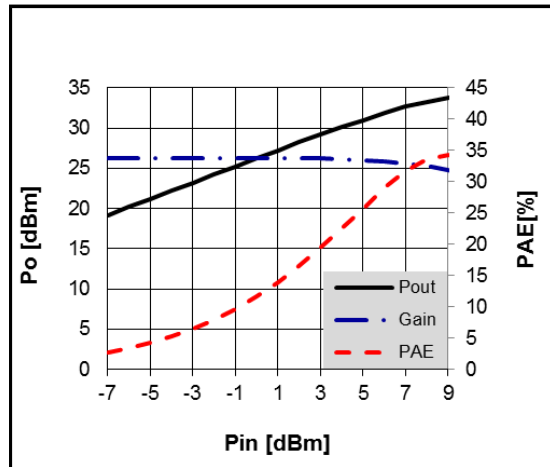
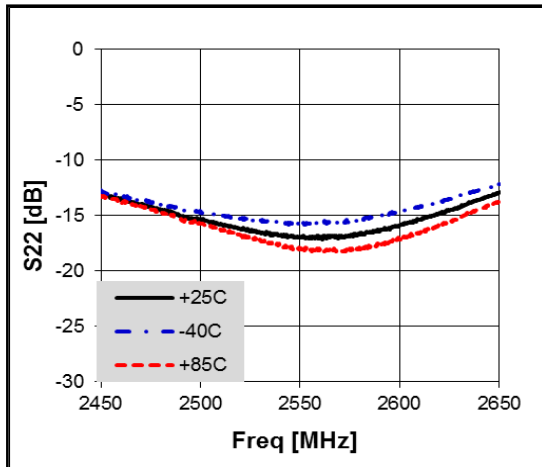
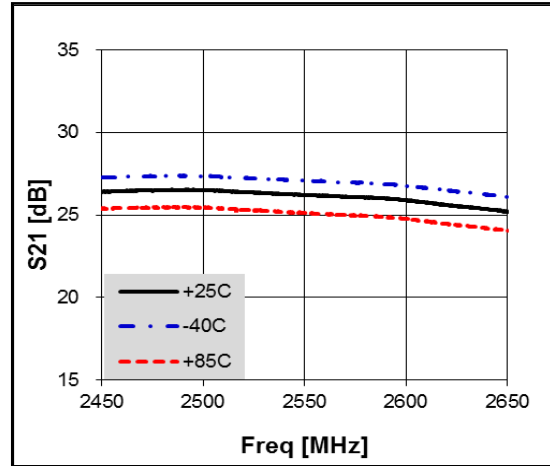
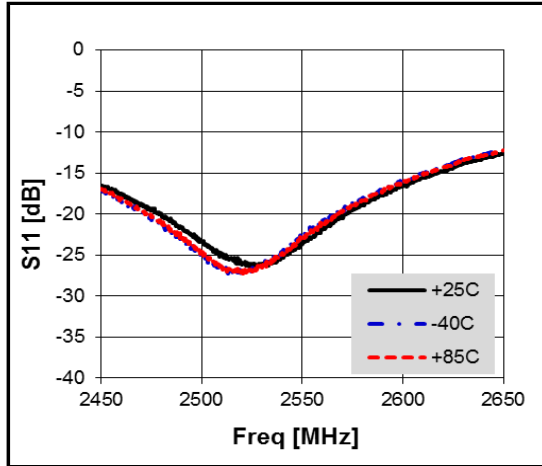
3GPP LTE E-TM3.1 20MHz

Application Circuit: 2550 MHz

Schematic Diagram	BOM	Marks
	C1	1206 10uF Tantalum
	C2	0603 1nF
	C3	0603 680pF COG/NPO
	C4	0603 N/A
	C5	0603 1nF
	C6	0603 27pF COG/NPO
	C7	0603 0 Ω Jumper
	C8	0603 1.0pF
	C9	0603 1.5pF
	C10	0603 3.0pF High Q Cap
	C11	0603 10pF
	C12	0603 1nF
	C13	0603 100pF
	C14	0603 1nF
	C15	1206 10uF Tantalum
L1	0603 N/A	
L2	0603 0 Ω Jumper	
L3	1008 18nH High Q Coil	
R1	0603 150 Ω ±5%	
R2	0603 270 Ω ±5%	

PCB Diagram	Notice																								
	Below information is subject to change as conditions of the substrate.																								
	<table border="1"> <thead> <tr> <th>Reference</th> <th>Object</th> <th>Distance</th> </tr> </thead> <tbody> <tr> <td>Input pin</td> <td>C8</td> <td>4.1mm</td> </tr> <tr> <td>Input pin</td> <td>C9</td> <td>2.2mm</td> </tr> <tr> <td>Output pin</td> <td>C10</td> <td>1.8mm</td> </tr> <tr> <td>Pin 16</td> <td>C3</td> <td>3.0mm</td> </tr> <tr> <td>Pin 16</td> <td>C6</td> <td>2.0mm</td> </tr> <tr> <td>Pin 19</td> <td>C5</td> <td>1.0mm</td> </tr> <tr> <td>Pin 20</td> <td>C4</td> <td>5.0mm</td> </tr> </tbody> </table>	Reference	Object	Distance	Input pin	C8	4.1mm	Input pin	C9	2.2mm	Output pin	C10	1.8mm	Pin 16	C3	3.0mm	Pin 16	C6	2.0mm	Pin 19	C5	1.0mm	Pin 20	C4	5.0mm
	Reference	Object	Distance																						
	Input pin	C8	4.1mm																						
	Input pin	C9	2.2mm																						
	Output pin	C10	1.8mm																						
	Pin 16	C3	3.0mm																						
Pin 16	C6	2.0mm																							
Pin 19	C5	1.0mm																							
Pin 20	C4	5.0mm																							
<p>1. Pin 16 & 20 is used for Vce of the inner bias circuit. To eliminate bias line resonance you need above 10mm transmission line and adjust the position of C2, C3, C4, C5 and C6. Also you can adjust spectrum regrowth about bandwidth of signals which you want.</p>																									
<p>2. C10 : We recommend High-Q capacitor for better output power performance. In this document we used 3.0pF(251R14S3R0BV4, EIA 0603) of Johanson Technology.</p>																									
<p>3. C7 & L2 are just jumpers as 0Ω</p>																									
<p>BeRex 141211 2.55GHz</p> <p>BMT333 EV Board Ver 1.0 Size = 39.3 X 29.5 mm Copper = 1oz.</p>																									

1800-2700 MHz 2W High Linearity 5V 2-Stage Power Amplifier
Typical Performance
 $(V_{cc} \& V_{Bias} = +5V, I_{cq} = 550mA, T_a = 25\text{ }^\circ\text{C})$

1800-2700 MHz 2W High Linearity 5V 2-Stage Power Amplifier

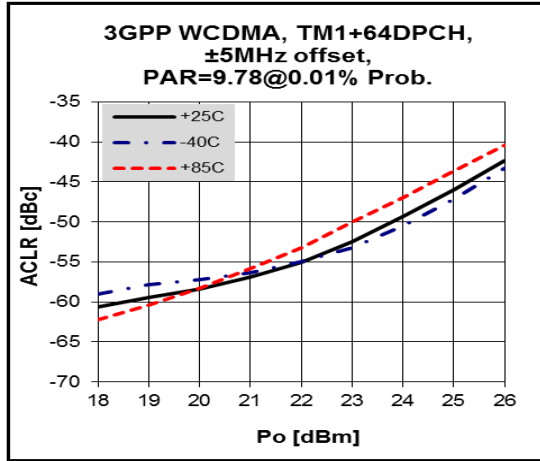

3GPP WCDMA TM1 +64DPCH 1FA

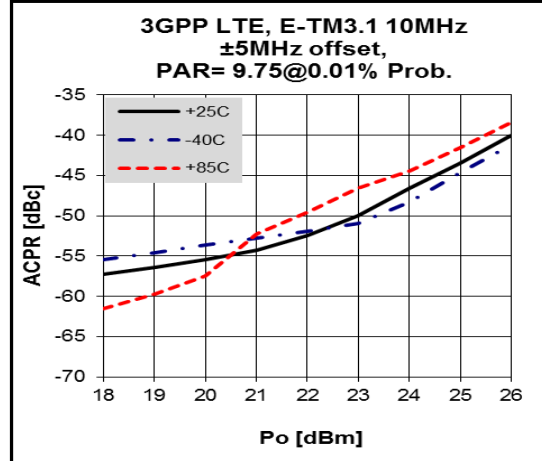

3GPP LTE E-TM3.1 10MHz

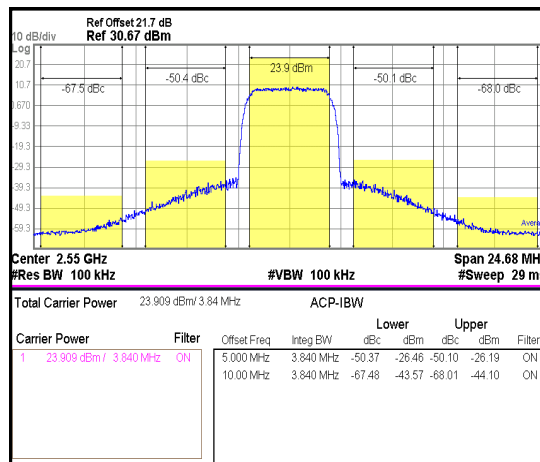

3GPP WCDMA TM1 +64DPCH 4FA

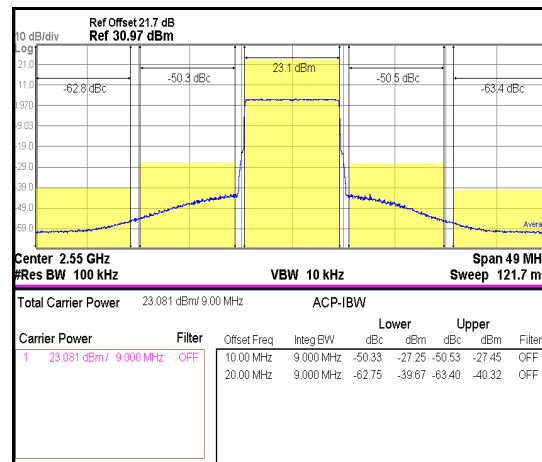

3GPP LTE E-TM3.1 20MHz

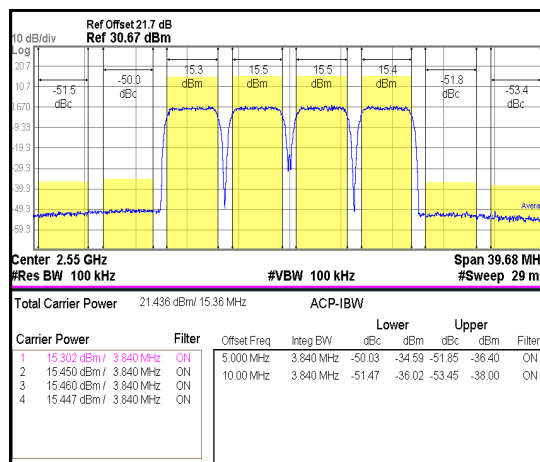

3GPP WCDMA TM1 +64DPCH 4FA

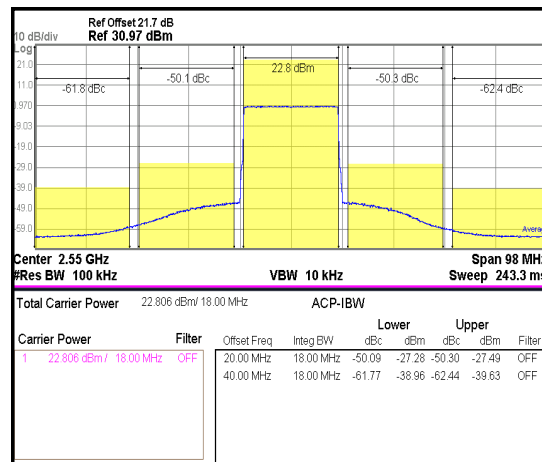

3GPP LTE E-TM3.1 20MHz

Application Circuit: 2650 MHz

Schematic Diagram	BOM	Marks		
	C1	1206 10uF	Tantalum	
	C2	0603	N/A	
	C3	0603	680pF	COG/NPO
	C4	0603	1nF	
	C5	0603	1nF	
	C6	0603	27pF	COG/NPO
	C7	0603	0 Ω	Jumper
	C8	0603	1.0pF	
	C9	0603	1.2pF	
	C10	0603	3.0pF	High Q Cap
	C11	0603	10pF	
	C12	0603	1nF	
	C13	0603	100pF	
	C14	0603	1nF	
	C15	1206	10uF	Tantalum
L1	0603	N/A		
L2	0603	0 Ω	Jumper	
L3	1008	18nH	High Q Coil	
R1	0603	150 Ω	±5%	
R2	0603	270 Ω	±5%	

PCB Diagram	Notice																								
<p>BeRex 141211 2.65GHz</p> <p>BMT333 EV Board Ver 1.0 Size = 39.3 X 29.5 mm Copper = 1oz.</p> <p>R04003C Er = 3.55 Thk. = 12 mil Width = 0.646 mm Clearance = 0.366 mm</p>	<p>Below information is subject to change as conditions of the substrate.</p> <table border="1"> <thead> <tr> <th>Reference</th> <th>Object</th> <th>Distance</th> </tr> </thead> <tbody> <tr> <td>Input pin</td> <td>C8</td> <td>3.6mm</td> </tr> <tr> <td>Input pin</td> <td>C9</td> <td>2.8mm</td> </tr> <tr> <td>Output pin</td> <td>C10</td> <td>0.8mm</td> </tr> <tr> <td>Pin 16</td> <td>C3</td> <td>6.2mm</td> </tr> <tr> <td>Pin 16</td> <td>C6</td> <td>2.2mm</td> </tr> <tr> <td>Pin 19</td> <td>C5</td> <td>1.0mm</td> </tr> <tr> <td>Pin 20</td> <td>C4</td> <td>5.0mm</td> </tr> </tbody> </table>	Reference	Object	Distance	Input pin	C8	3.6mm	Input pin	C9	2.8mm	Output pin	C10	0.8mm	Pin 16	C3	6.2mm	Pin 16	C6	2.2mm	Pin 19	C5	1.0mm	Pin 20	C4	5.0mm
	Reference	Object	Distance																						
	Input pin	C8	3.6mm																						
	Input pin	C9	2.8mm																						
	Output pin	C10	0.8mm																						
	Pin 16	C3	6.2mm																						
	Pin 16	C6	2.2mm																						
	Pin 19	C5	1.0mm																						
	Pin 20	C4	5.0mm																						
		<p>1. Pin 16 & 20 is used for Vce of the inner bias circuit. To eliminate bias line resonance you need above 10mm transmission line and adjust the position of C2, C3, C4, C5 and C6. Also you can adjust spectrum regrowth about bandwidth of signals which you want.</p>																							
	<p>2. C10 : We recommend High-Q capacitor for better output power performance. In this document we used 3.0pF(251R14S3R0BV4, EIA 0603) of Johanson Technology.</p>																								
	<p>3. C7 & L2 are just jumpers as 0Ω</p>																								

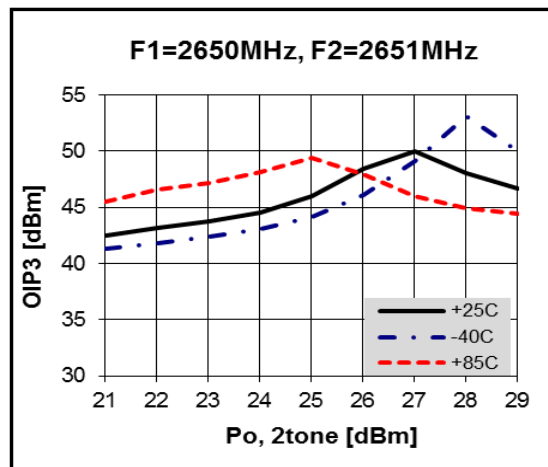
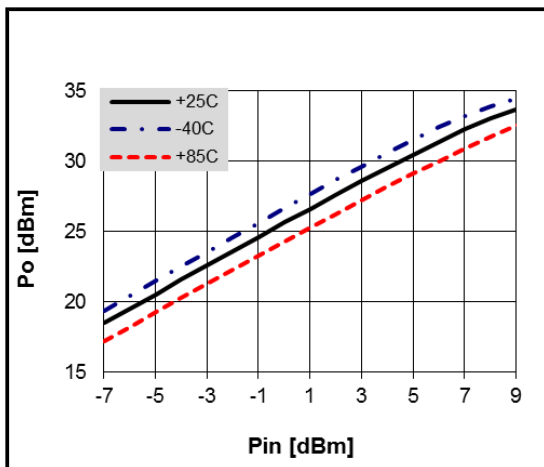
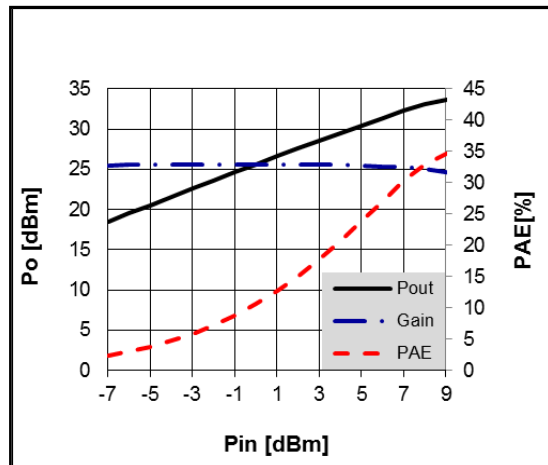
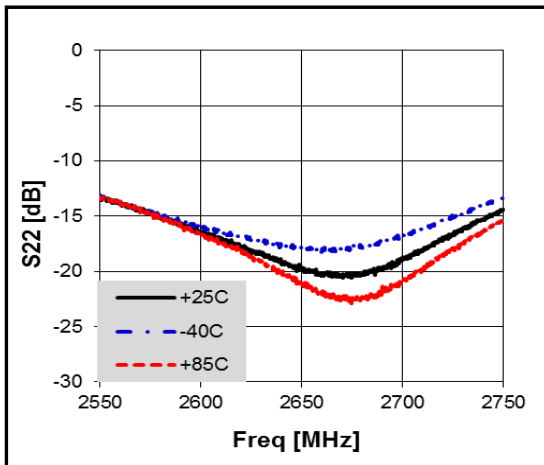
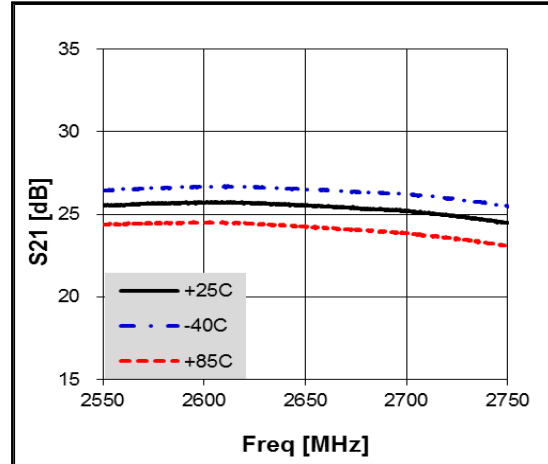
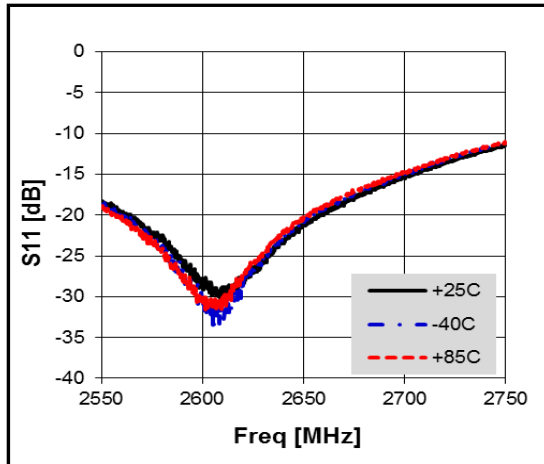
1800-2700 MHz 2W High Linearity 5V 2-Stage Power Amplifier
Typical Performance
 $(V_{CC} \& V_{Bias} = +5V, I_{CQ} = 550mA, T_a = 25\text{ }^\circ\text{C})$

1800-2700 MHz 2W High Linearity 5V 2-Stage Power Amplifier

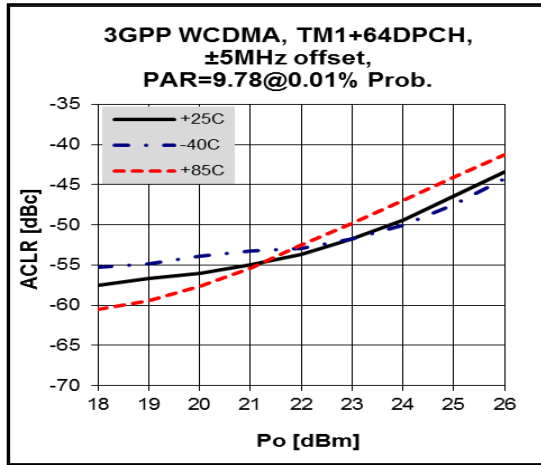

3GPP WCDMA TM1 +64DPCH 1FA

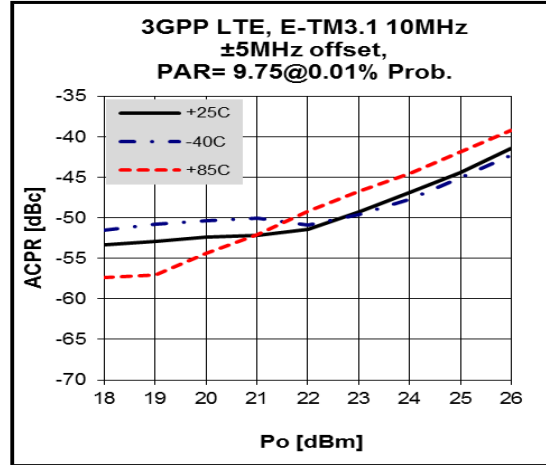

3GPP LTE E-TM3.1 10MHz

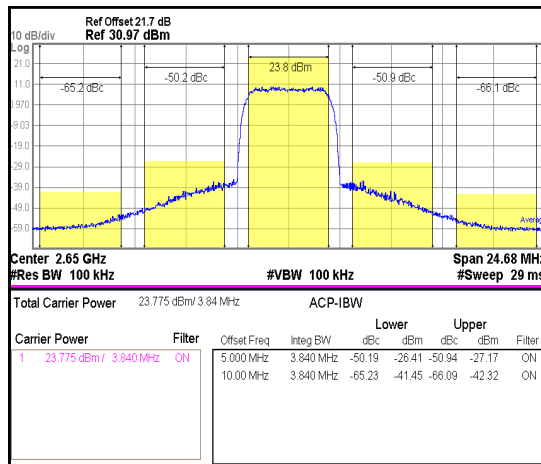

3GPP WCDMA TM1 +64DPCH 4FA

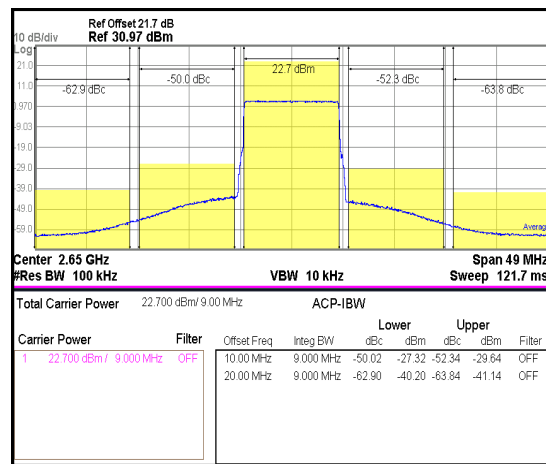

3GPP LTE E-TM3.1 20MHz

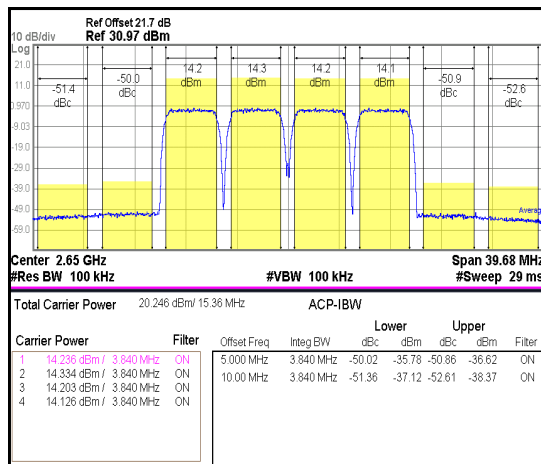

3GPP WCDMA TM1 +64DPCH 4FA

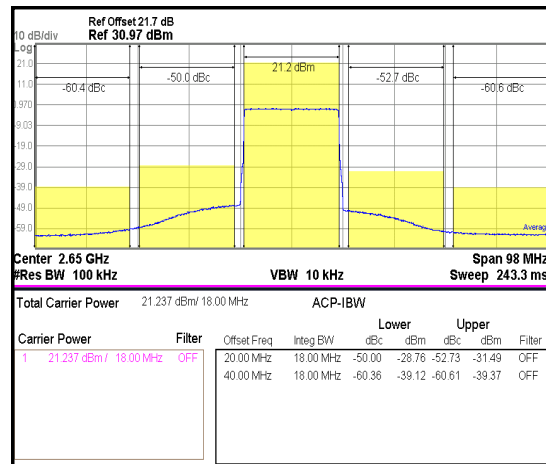

3GPP LTE E-TM3.1 20MHz

Typical Performance (Pout vs. Icc)

(V_{CC} & $V_{Bias} = +5V$, $I_{CQ} = 550mA$, $T_a = 25\text{ }^\circ C$)

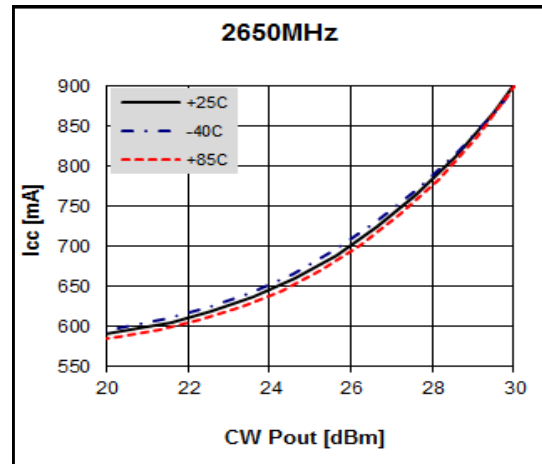
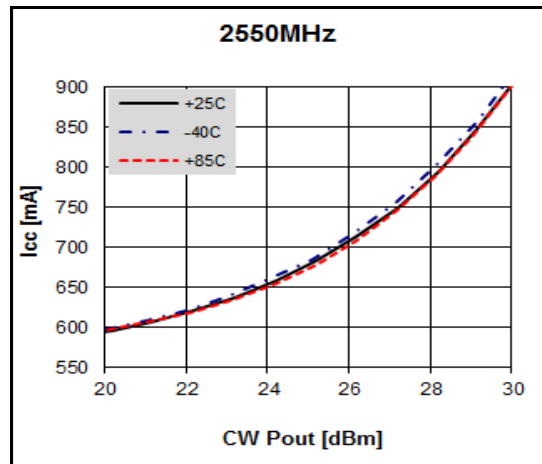
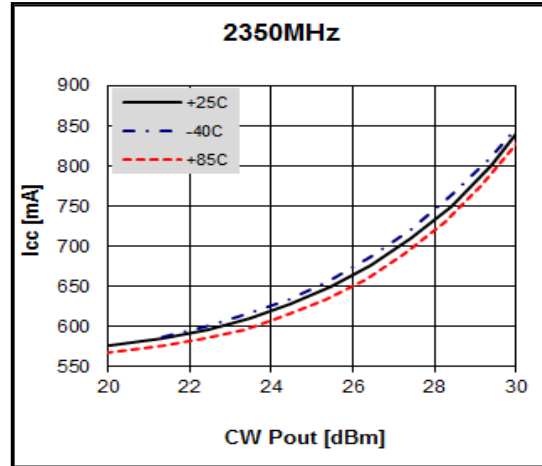
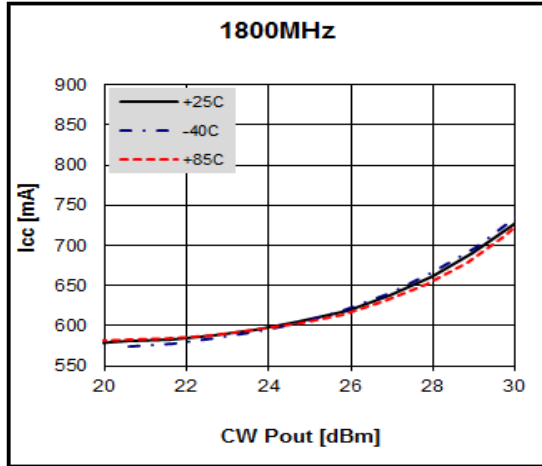

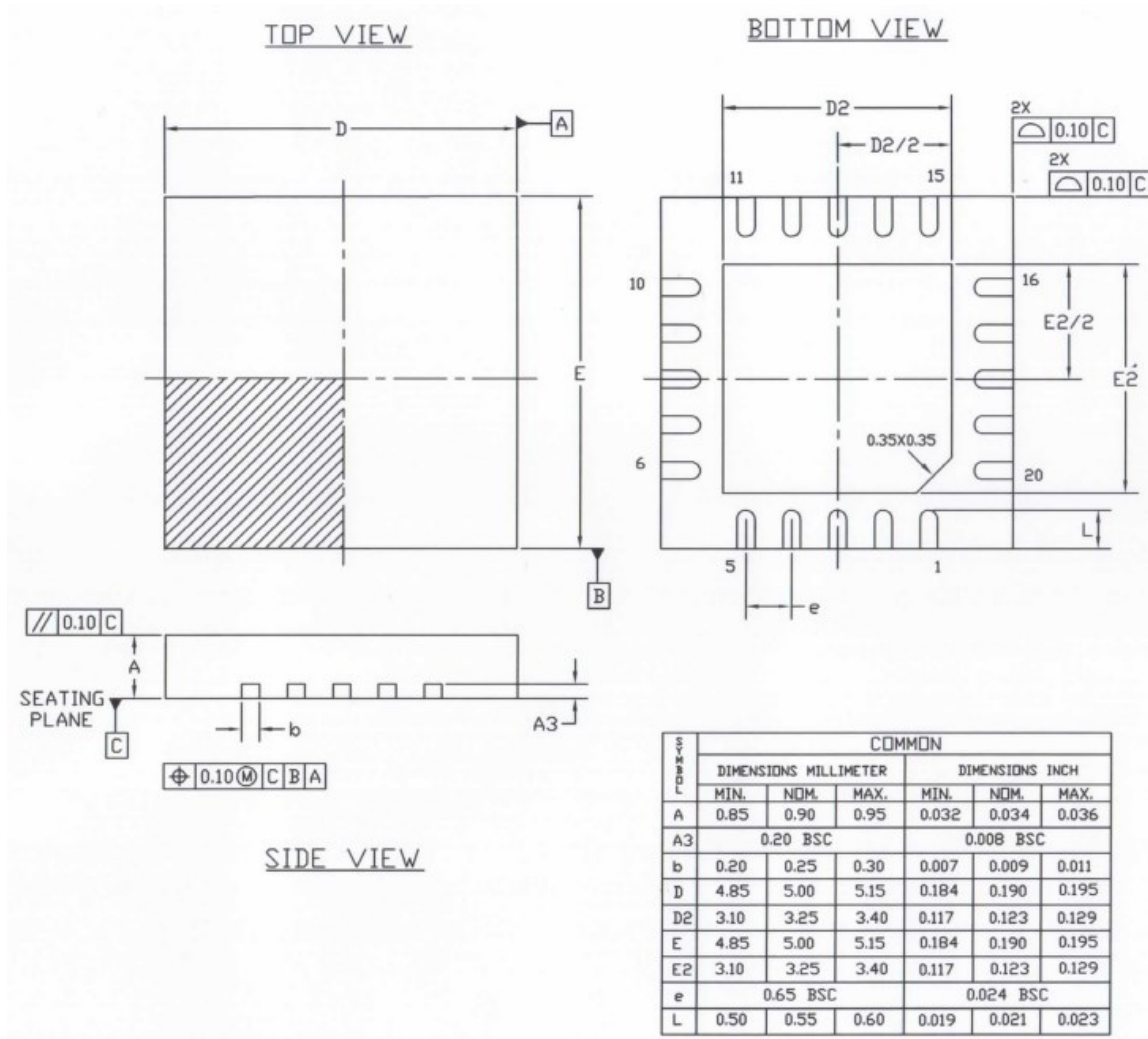
Package Outline Dimension

NOTES :

1. DIMENSION AND TOLERANCING CONFORM TO ASME Y14.5M-1994.
2. CONTROLLING DIMENSIONS : MILLIMETER. CONVERTED INCH DIMENSION ARE NOT NECESSARILY EXACT.
3. DIMENSION b APPLIES TO METALLIZED TERMINAL AND IS MEASURED BETWEEN 0.15 AND 0.30 MM. FROM TERMINAL TIP.
4. INSULATION THICKNESS, CLEARANCE OF OVERLAP ARE USER DEFINED.
5. INSULATION NOT COMPLETELY SHOWN FOR REASONS OF CLARITY.

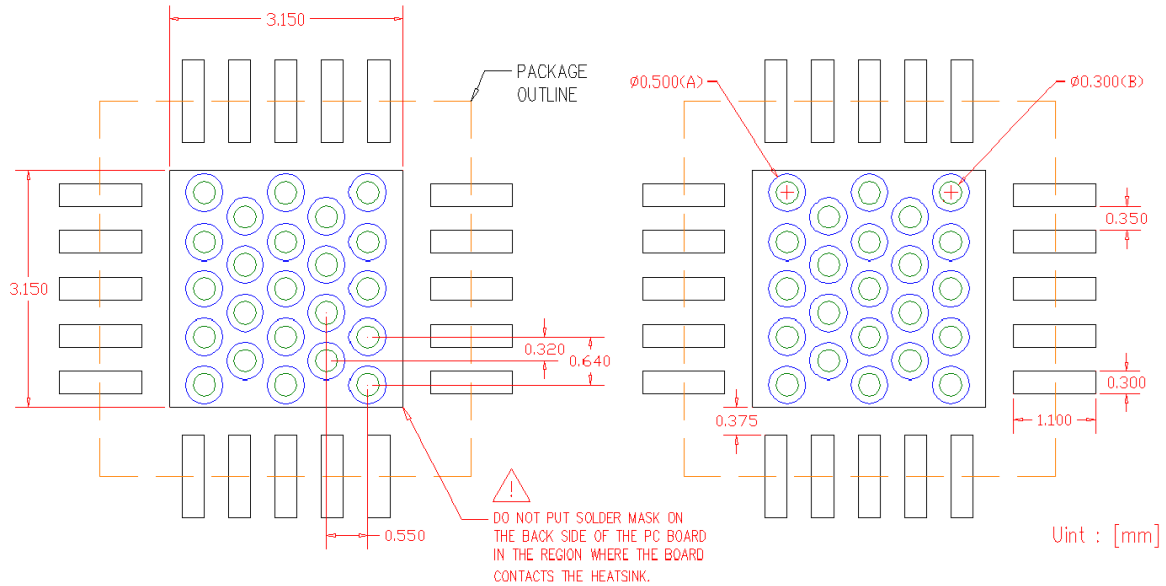
Suggested PCB Land Pattern and PAD Layout



Notes

1. Use 1 oz. copper minimum for top and bottom layer metal.
2. A heatsink underneath the area of the PCB for the mounted device is required for proper thermal operation.
3. Ground / thermal vias are critical for the proper performance of this device.

Vias should use a 0.5 mm(A) diameter drill and have a final plated thru diameter of 0.3 mm(B).

Package Marking

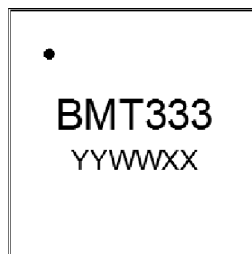

YY = Year, WW = Working Week,
XX = Wafer No.

PCB Mounting

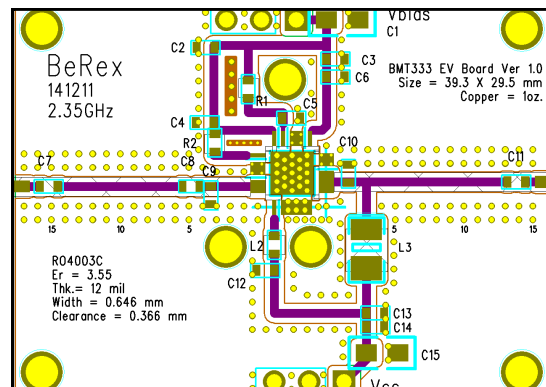

Tape & Reel

QFN 5x5

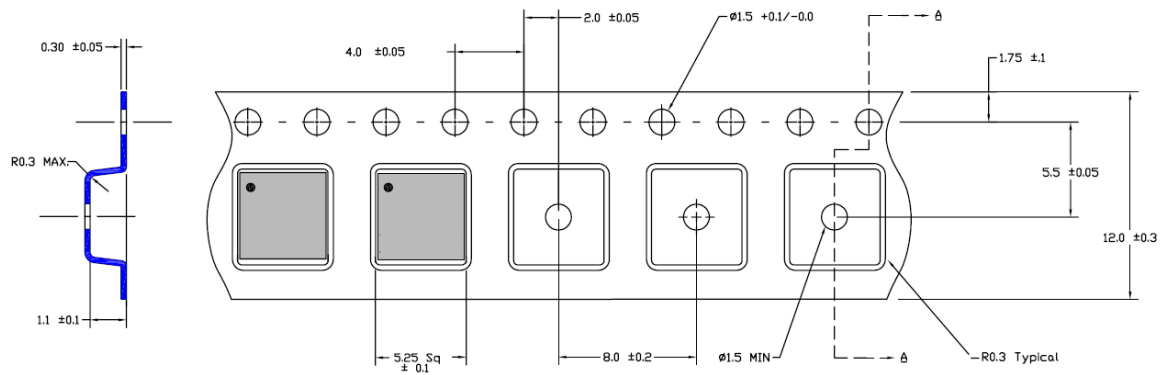

Packaging information :

Tape width(mm) : 12

Reel Size (inches) : 7

Device Cavity Pitch(mm) : 8

Devices Per Reel : 1000

Lead plating finish

100% Tin Matte finish

(All BeRex products undergoes a 1 hour, 150 degree C, Anneal bake to eliminate thin whisker growth concerns.)

MSL / ESD Rating

ESD Rating: Class 1C
Value: Passes $\geq 1000V$ to $< 2000 V$
Test: Human Body Model (HBM)
Standard: JEDEC Standard JS-001-2012

ESD Rating: Class C3
Value: Passes $>1000V$
Test: Charged Device Model (CDM)
Standard: JEDEC Standard JESD22-C101F

MSL Rating: Level 1 at $+260^{\circ}C$ convection reflow
Standard: JEDEC Standard J-STD-020



Proper ESD procedures should be followed when handling this device.

RoHS Compliance

This part is compliant with Restrictions on the Use of Certain Hazardous Substances in Electrical and Electronic Equipment (RoHS) Directive 2011/65/EU as amended by Directive 2015/863/EU.

This product also is compliant with a concentration of the Substances of Very High Concern (SVHC) candidate list which are contained in a quantity of less than 0.1%(w/w) in each components of a product and/or its packaging placed on the European Community market by the BeRex and Suppliers.

NATO CAGE code:

2	N	9	6	F
---	---	---	---	---

Looking for pricing, stock, or lifecycle information?

Click below to explore more details on WIN SOURCE:

-  [View BMT333 on WIN SOURCE](#)
-  [BeRex Corporation](#) Information

Optimize Your Supply Chain with WIN SOURCE Solutions

-  Global Sourcing Solution
-  Obsolete Management
-  Cost Control Management
-  Shortage Management
-  Alternative Solution
-  Excess Inventory Management