

Device Features

- OIP3 = 49.0 dBm @ 1900 MHz
- Gain = 12.5 dB @ 1900 MHz
- Output P1 dB = 30.3 dBm @ 1900 MHz
- Patented Over Voltage Protection Circuit
- RoHS2-compliant SOIC-8 package

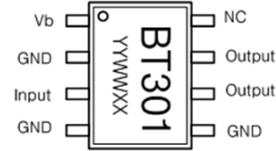

YY = Year, WW = Work week,
XX = Wafer Number

Product Description

BeRex's BT301 is a high power and a high dynamic range amplifier in a low cost surface mount package(SOIC-8) with a RoHS2-compliant, that incorporates reliable hetero-junction-bipolar-transistor (HBT) devices fabricated with InGaP GaAs technology. This device is designed for use where high linearity is required and features high OIP3 and Power with low consumption current (350mA) and requires a few external matching components such as a DC blocking capacitors on the In/Output pin, a bypass capacitor and a RF choke for the out port. All devices are 100% RF/DC tested.

Applications

- Base station Infrastructure/RFID
- Commercial/Industrial/Military wireless system
- Wireless LAN

Application Circuits

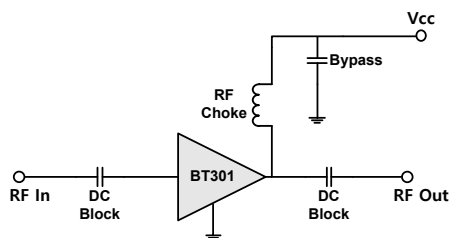

*External matching circuit: refer to the page 4 to 11.

Electrical Specifications

Device performance _ measured on a BeRex evaluation board at 25°C, Vc=5V, 50 Ω system.

Parameter	Conditions	Min	Typ	Max	Unit
Operational Frequency Range		500		4000	MHz
Test Frequency			1900		MHz
Gain		11.0	12.5		dB
Input Return Loss			-18.0		dB
Output Return Loss			-12.0		dB
Output IP3	16 dBm/tone, Δf=1 MHz	46.0	49.0		dBm
Output P1dB		28.3	30.3		dBm
IS-95C ACPR*		21.5	22.5		dBm
Noise Figure			8.6		dB

*ACPR&ACLR CH Power _ measured at 50dBc.

*ACPR Test set-up: IS-95 CDMA, 9Ch. FWD, +885KHz offset.

*ACLR Test set-up: 3GPP WCDMA, TM1+64DPCH, +5MHz offset.

Recommended Operating Conditions

Parameter	Min	Typ	Max	Unit
Bandwidth	500		4000	MHz
I _c @ (V _c = 5V)	280	350	420	mA
V _c	4.75	5.0	5.25	V
R _{TH}		19.6		°C/W
Operating Case Temperature	-40		+85	°C

Electrical specifications are measured at specified test conditions.

Specifications are not guaranteed over all recommended operating conditions.

Absolute Maximum Ratings

Parameter	Rating	Unit
Storage Temperature	-55 to +155	°C
Junction Temperature	+185	°C
Supply Voltage	+6.0	V
Supply Current	600	mA
Input RF Power	28	dBm

*Operation of this device above any of these parameters may result in permanent damage.

Typical Performance (Vc=5V, Ic=350mA, T=25°C)

Parameter	Frequency					Unit
	900	1900	2140	2450	3500	MHz
Gain	18.5	12.5	11.5	10.5	7.6	dB
S11	-15.0	-18.0	-18.0	-12.0	-23.2	dB
S22	-7.0	-12.0	-12.0	-11.0	-17.4	dB
OIP3	49.0	49.0	47.0	49.0	42.5	dBm
P1dB	29.5	30.3	30.3	30.3	27.9	dBm
IS-95C ACPR	22.5	22.5	-	-	-	dBm
WCDMA ACLR	-	-	21.0	21.0	18.4	dBm
Noise Figure	8.5	8.6	7.5	7.5	7.3	dB

V-I Characteristics

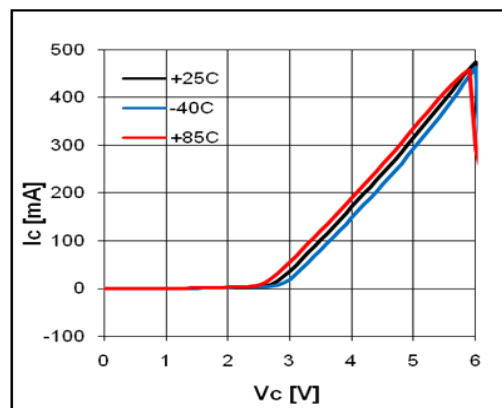

BeRex SOIC-8 Evaluation Board

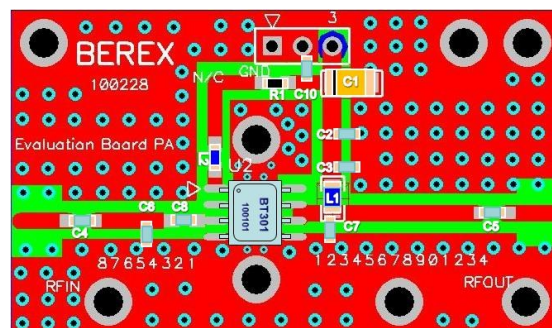

*Dielectric constant _ 4.2 *RF pattern width 52mil *31mil thick FR4 PCB

Typical Device Data

S-parameters (Vc=5V, Ic=350mA, T=25°C)

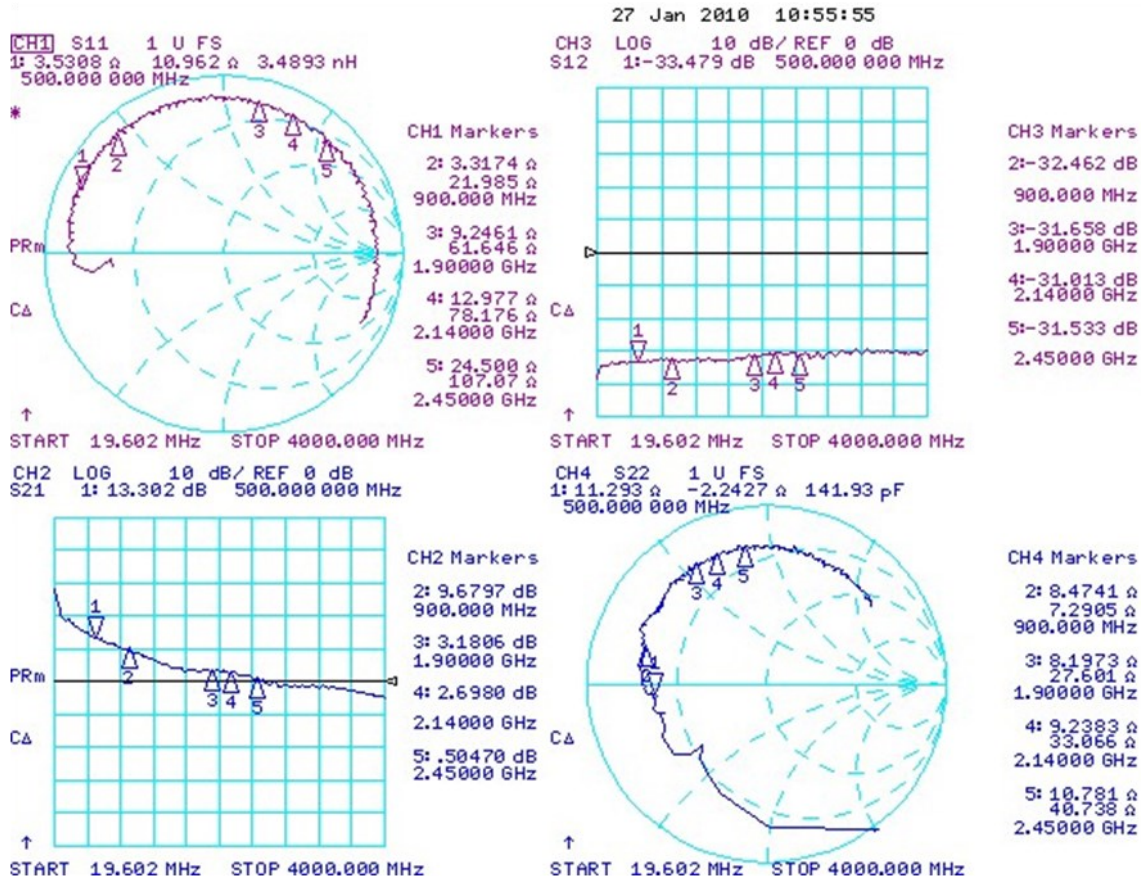

S-Parameter

(Vdevice = 5.0V, Icc = 350mA, T = 25 °C, calibrated to device leads)

Freq [MHz]	S11 [Mag]	S11 [Ang]	S21 [Mag]	S21 [Ang]	S12 [Mag]	S12 [Ang]	S22 [Mag]	S22 [Ang]
100	0.842	-178.0	11.489	131.4	0.019	18.2	0.534	-134.7
500	0.895	157.3	4.894	104.8	0.023	10.6	0.659	-176.7
1000	0.893	130.8	2.766	83.9	0.022	9.8	0.754	160.4
1500	0.870	106.2	1.658	75.1	0.025	21.7	0.773	139.8
2000	0.852	82.2	1.512	64.0	0.027	21.5	0.761	120.1
2500	0.840	58.8	1.047	47.2	0.026	21.6	0.773	101.7
3000	0.841	35.6	0.888	50.8	0.029	16.4	0.792	83.2
3500	0.850	12.5	0.840	36.8	0.031	23.4	0.659	62.6
4000	0.879	-6.4	0.542	24.0	0.031	16.3	0.634	41.3

Application Circuit: 900 MHz

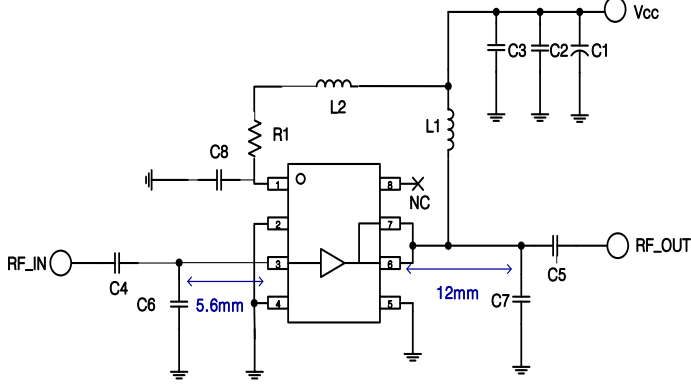
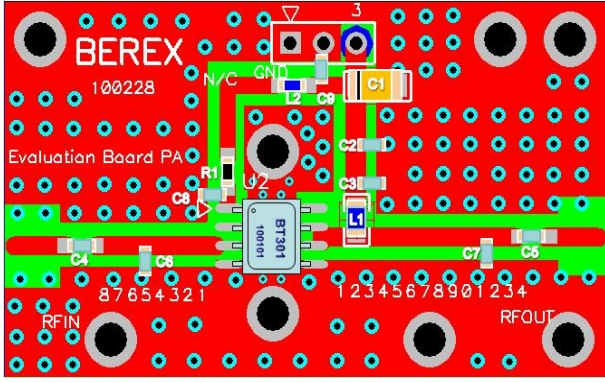
Schematic Diagram	BOM			Tolerance
	C1	1206	10uF	±20%
	C2	0603	1.0nF	±5%
	C3	0603	100pF	±5%
	C4	0603	3pF	±5%
	C5	0603	100pF	±5%
	C6	0603	4.7pF	±5%
	C7	0603	5.0pF	±5%
	C8	0603	2.7pF	±5%
	R1	0603	12ohm	±5%
L1	1008	56nH	±5%	
L2	0603	4.7nH	±5%	
PCB Diagram	Notice			
	<ol style="list-style-type: none"> 1. PCB: 31mil thick FR4 2. Distance between the center of the shunt Inductor(C6) and the input pin of BT301 _ 5.6 mm. 3. Distance between the center of the shunt cap. (C7) and the output pin of BT301 _ 12 mm. <p>※ BT301 with both input and output ports opened simultaneously may cause instability. Please See an application note or contact company for application support.</p>			

Typical Performance

(Vc=5V, Ic=350mA, T=25°C)

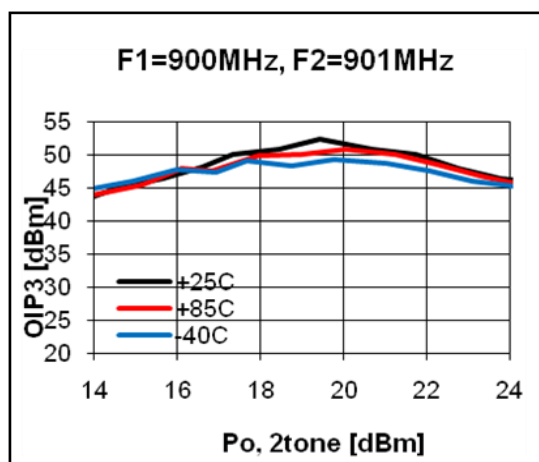
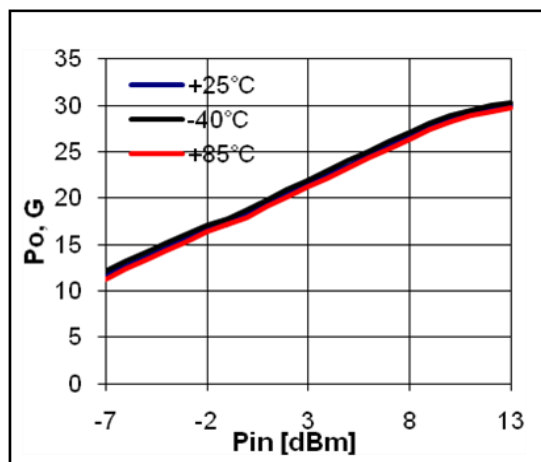
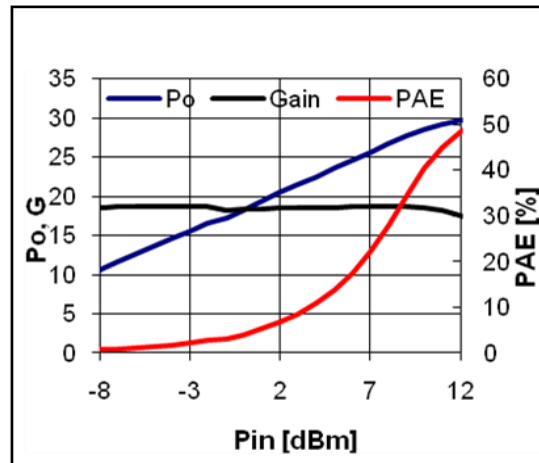
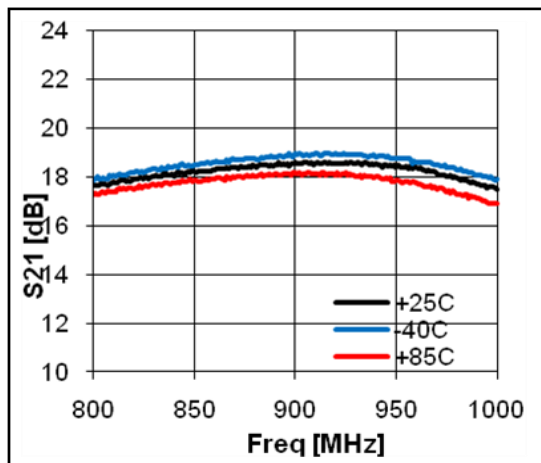
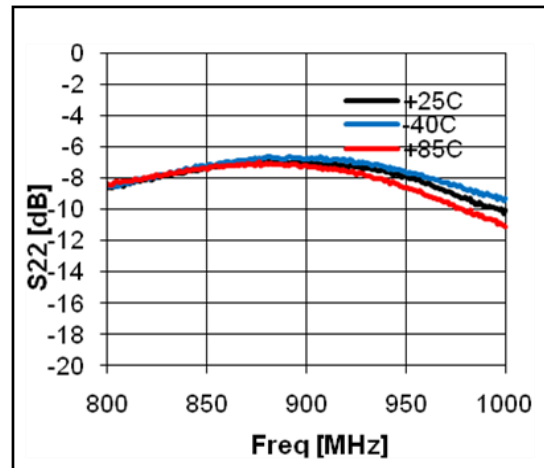
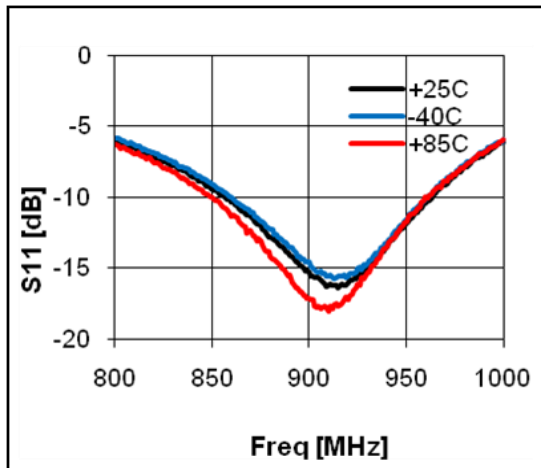

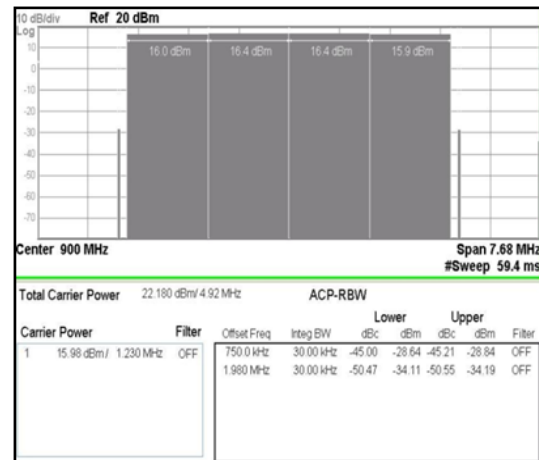
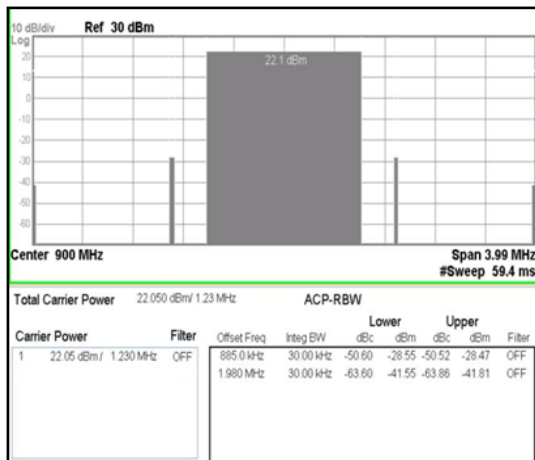
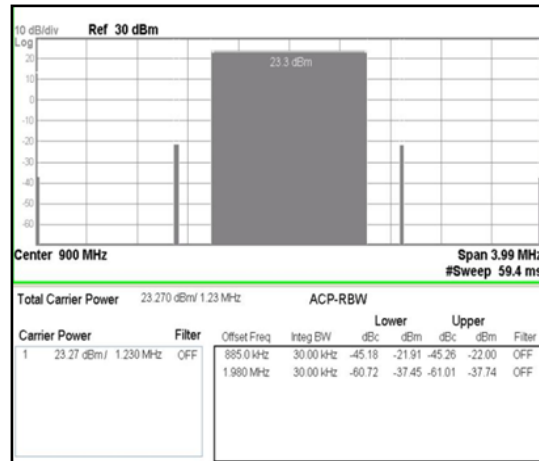
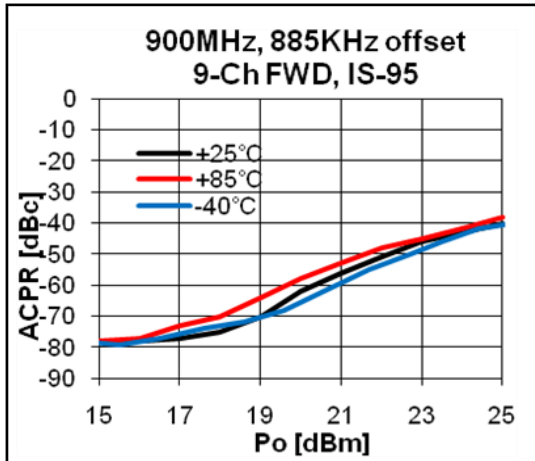

Application Circuit: 1900 MHz

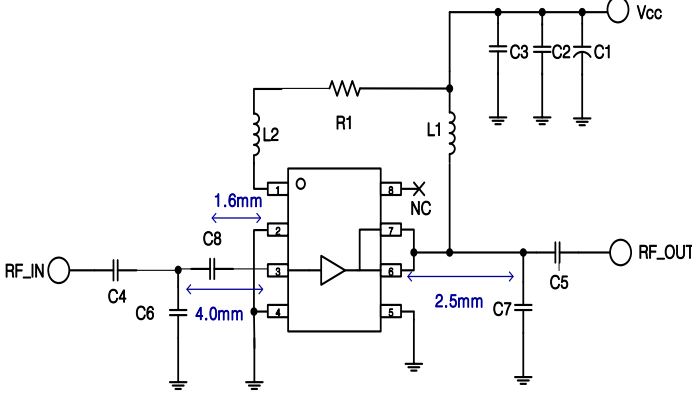
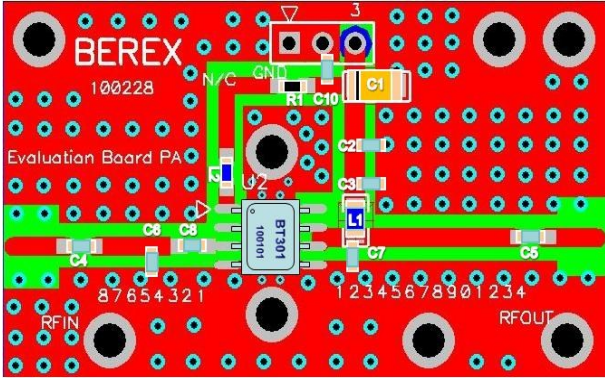
Schematic Diagram	BOM	Tolerance		
	C1	1206	10uF	±20%
	C2	0603	1nF	±5%
	C3	0603	100pF	±5%
	C4	0603	100pF	±5%
	C5	0603	100pF	±5%
	C6	0603	3pF	±5%
	C7	0603	2.5pF	±5%
	C8	0603	2.5pF	±5%
	R1	0603	12 ohm	±5%
	L1	1008	56nH	±5%
L2	0603	6.8nH	±5%	
PCB Diagram	Notice			
	<ol style="list-style-type: none"> 1. PCB: 31mil thick FR4 2. Distance between the center of the series cap. (C8) and the input pin of BT301 _ 1.6 mm. 3. Distance between the center of the shunt cap. (C6) and the input pin of BT301 _ 4.0 mm. 4. Distance between the center of the shunt cap. (C7) and the output pin of BT301 _ 2.5 mm. 			

Typical Performance

(Vc=5V, Ic=350mA, T=25°C)

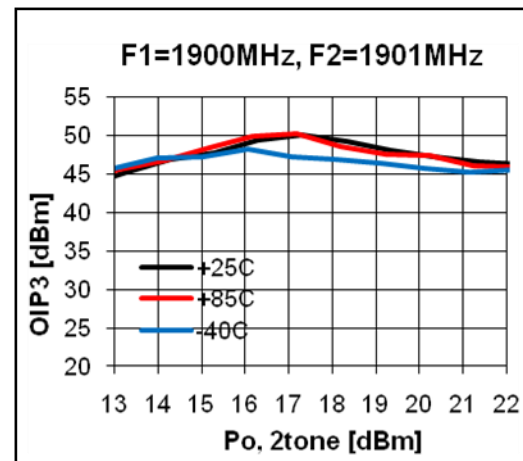
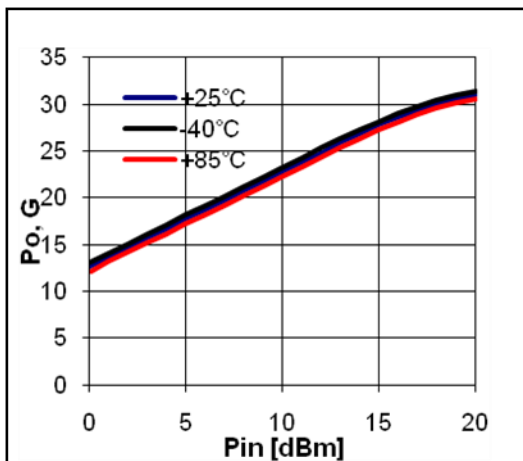
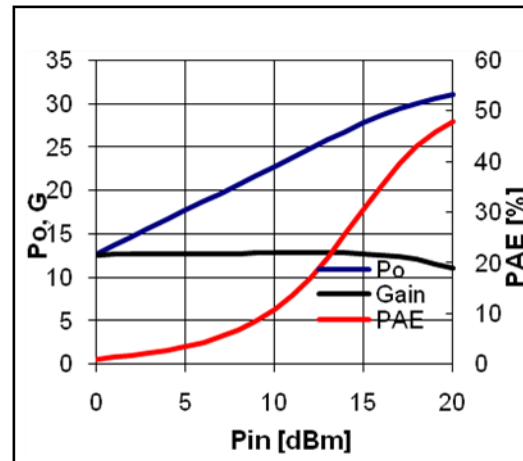
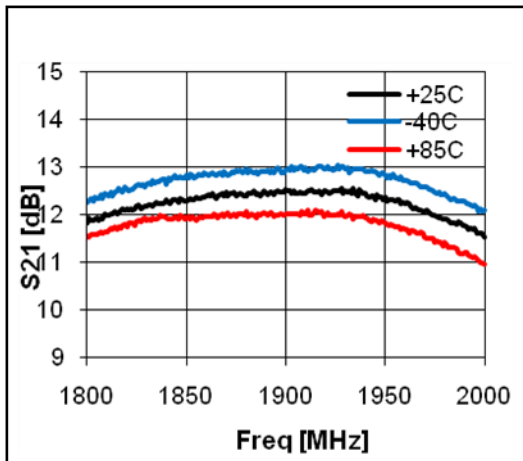
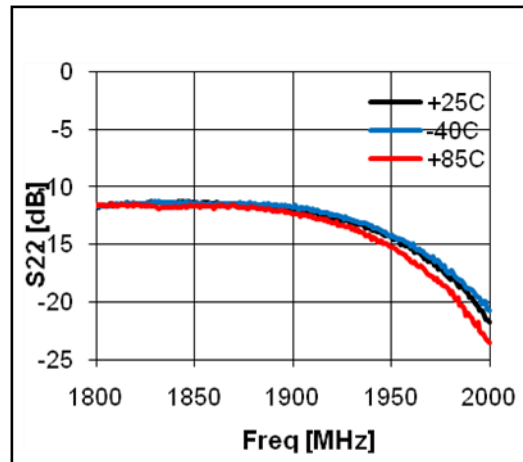
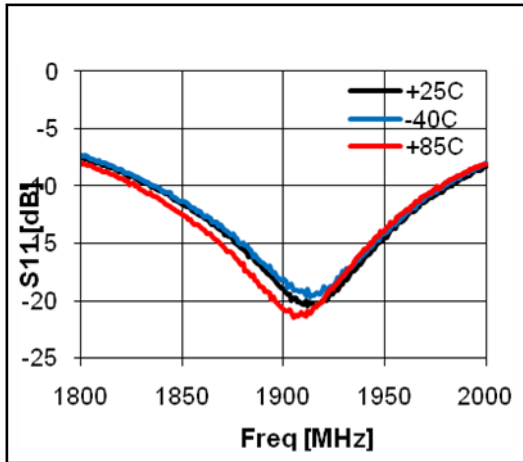

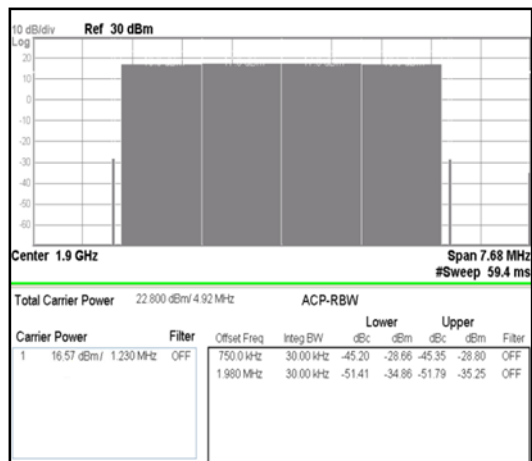
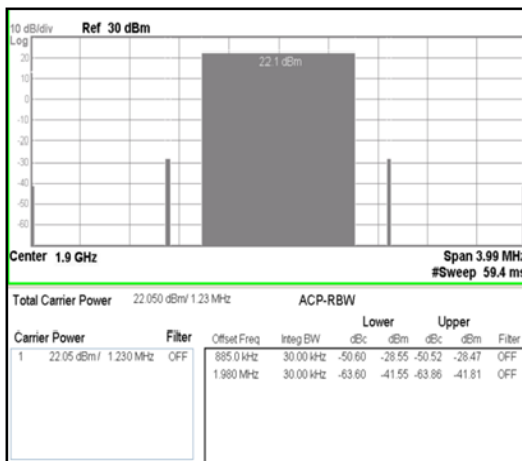
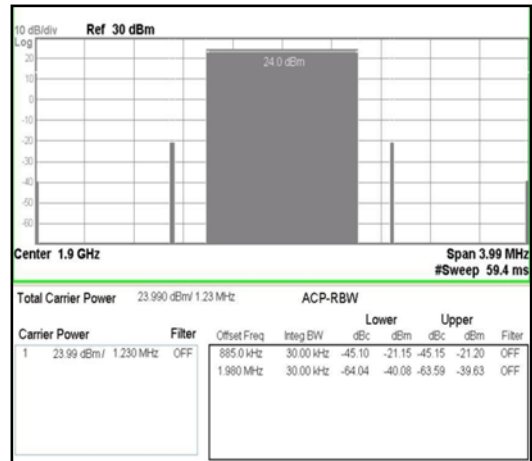
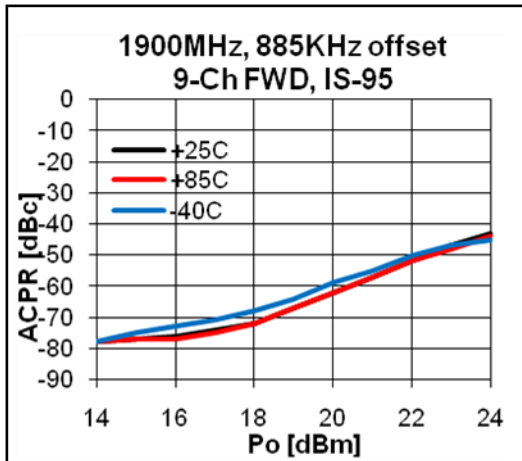

Application Circuit: 2140MHz

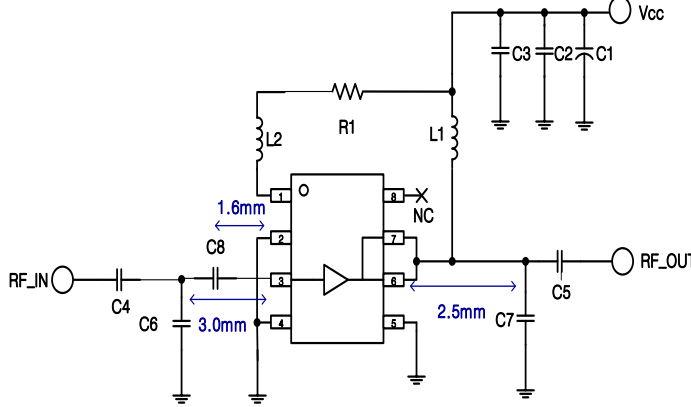
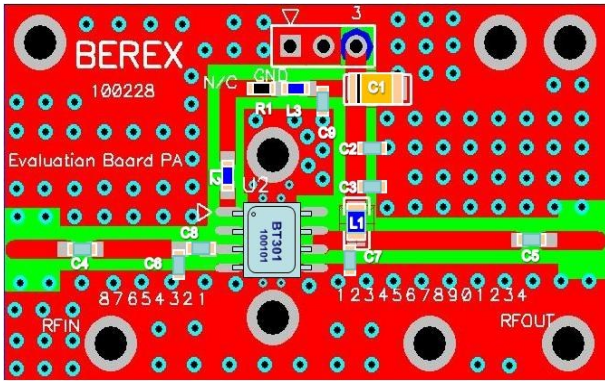
Schematic Diagram	BOM			Tolerance
	C1	1206	10uF	±20%
	C2	0603	1nF	±5%
	C3	0603	100pF	±5%
	C4	0603	100pF	±5%
	C5	0603	100pF	±5%
	C6	0603	2.5pF	±5%
	C7	0603	1.8pF	±5%
	C8	0603	1.8pF	±5%
	C9	0603	5.0pF	±5%
	R1	0603	12 ohm	±5%
L1	1008	56nH	±5%	
L2	0603	4.7nH	±5%	
PCB Diagram	Notice			
	<ol style="list-style-type: none"> 1. PCB: 31mil thick FR4 2. Distance between the center of the shunt cap. (C8) and the input pin of BT301 _ <u>1.6 mm</u>. 3. Distance between the center of the shunt cap. (C6) and the input pin of BT301 _ <u>3.0 mm</u>. 4. Distance between the center of the shunt cap. (C7) and the output pin of BT301 _ <u>2.5 mm</u>. 			

Typical Performance
(Vc=5V, Ic=350mA, T=25°C)

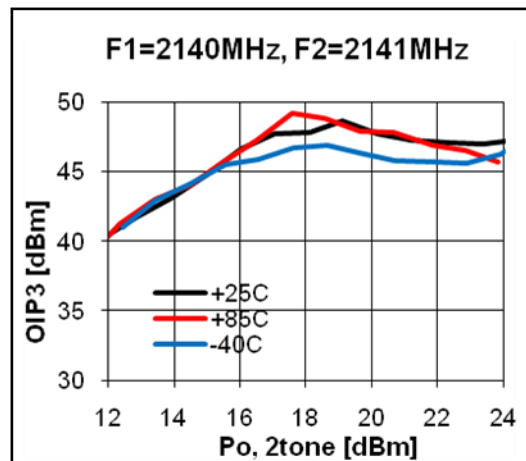
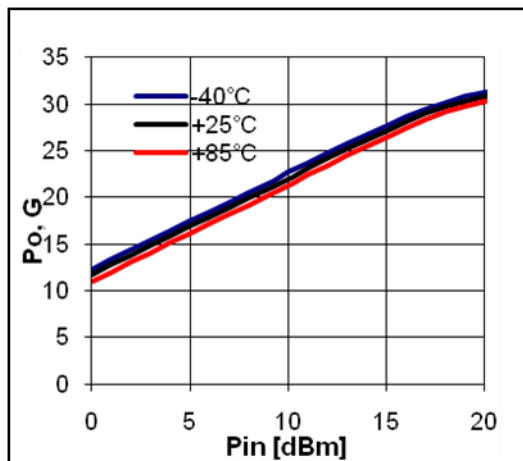
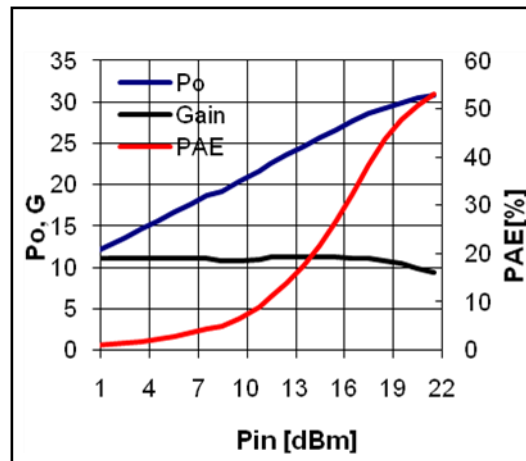
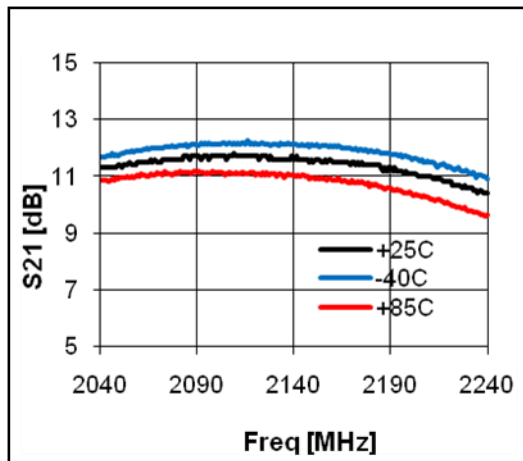
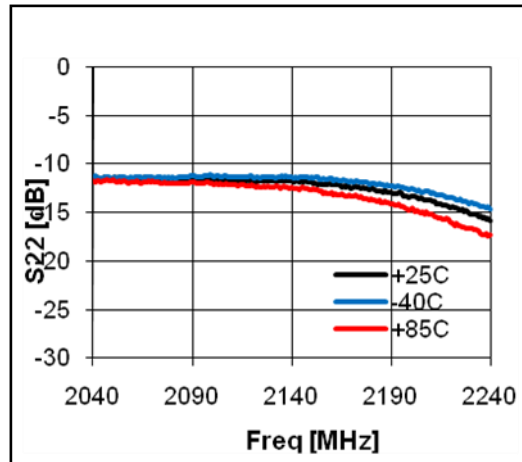
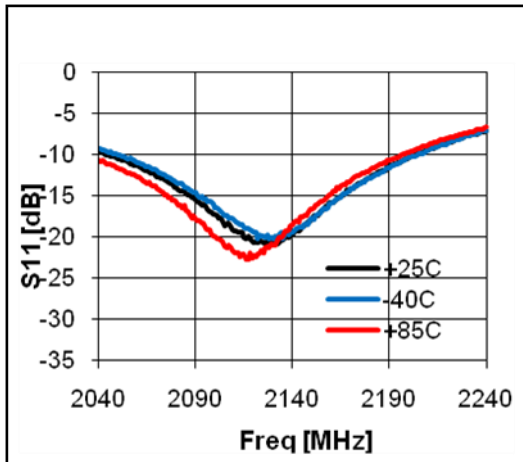

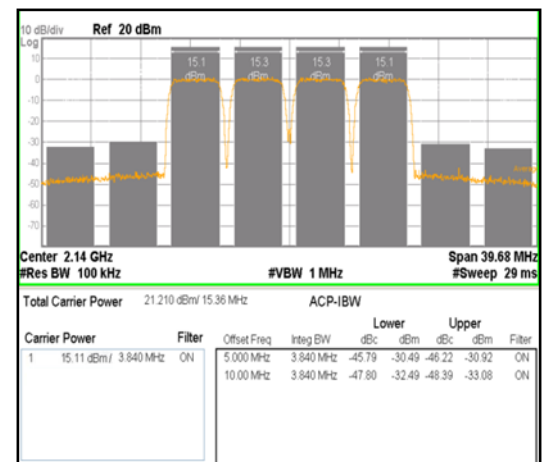
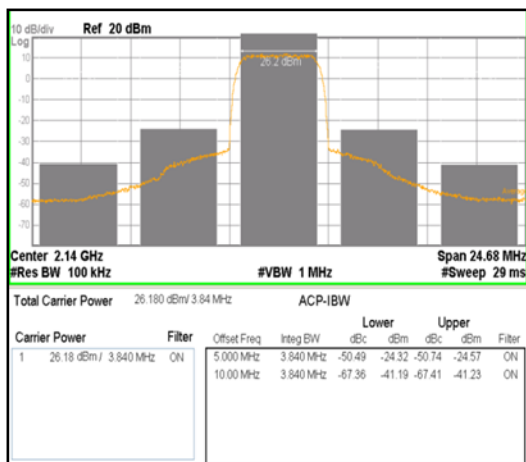
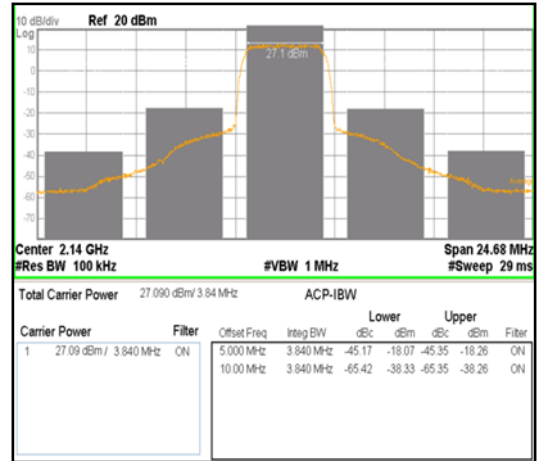
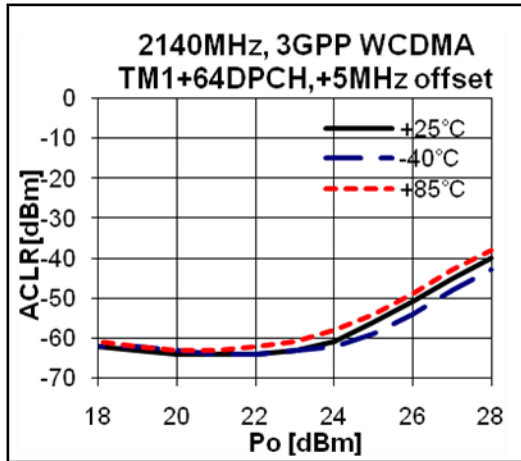

Application Circuit: 2450MHz

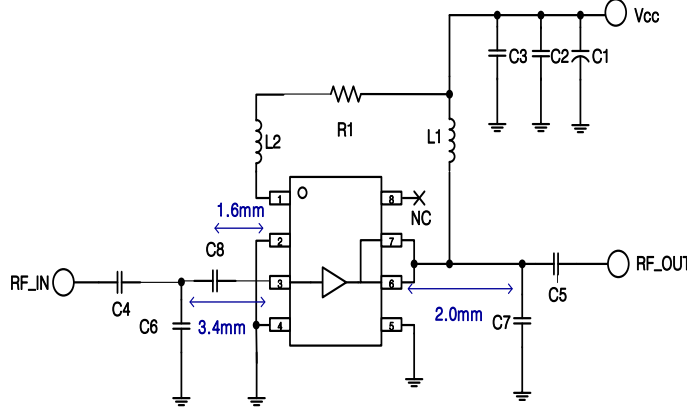
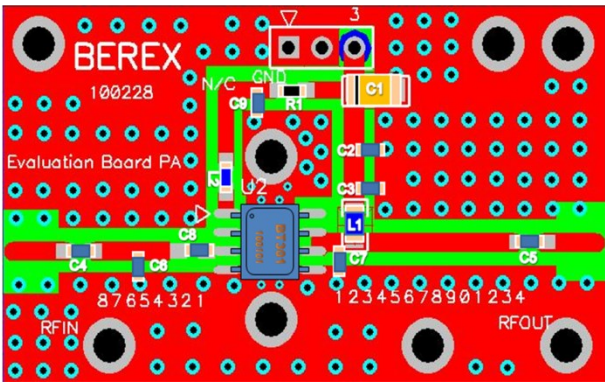
Schematic Diagram	BOM	Tolerance		
	C1	1206	10uF	±20%
	C2	0603	1nF	±5%
	C3	0603	100pF	±5%
	C4	0603	100pF	±5%
	C5	0603	100pF	±5%
	C6	0603	1.5pF	±5%
	C7	0603	1.5pF	±5%
	C8	0603	1.8pF	±5%
	R1	0603	12 ohm	±5%
L1	1008	56nH	±5%	
L2	0603	3.9nH	±5%	
PCB Diagram	Notice			
	<ol style="list-style-type: none"> 1. PCB: 31mil thick FR4 2. Distance between the center of the series cap. (C8) and the input pin of BT301 _ <u>1.6 mm</u>. 3. Distance between the center of the shunt cap. (C6) and the input pin of BT301 _ <u>3.4 mm</u>. 4. Distance between the center of the shunt cap. (C7) and the output pin of BT301 _ <u>2.0 mm</u>. 			

Typical Performance

(Vc=5V, Ic=350mA, T=25°C)

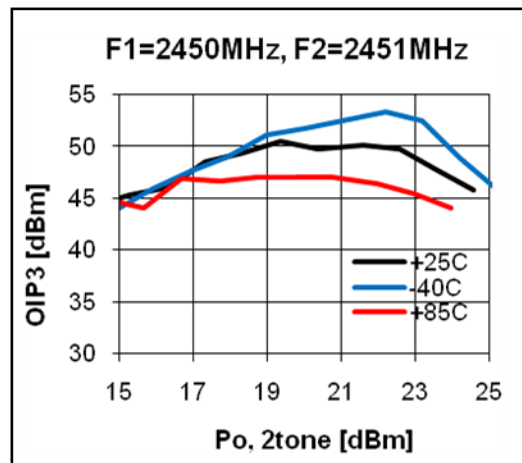
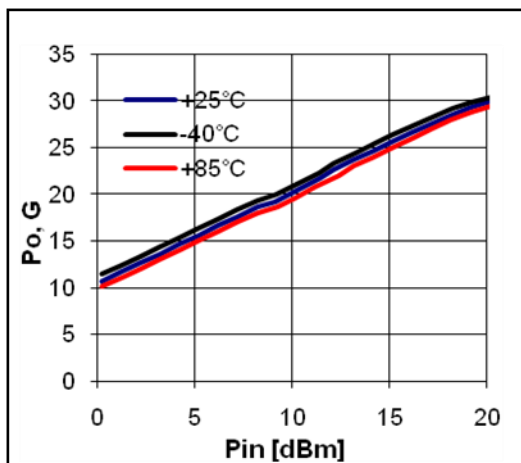
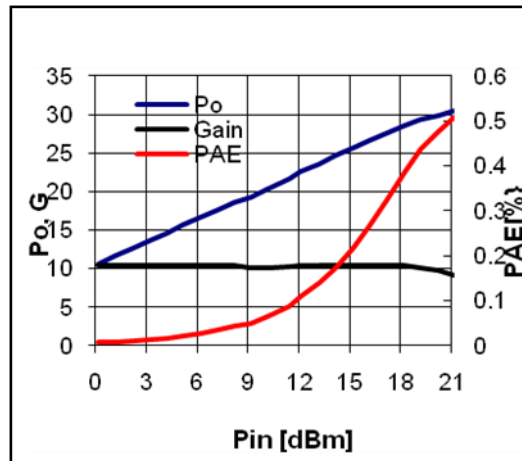
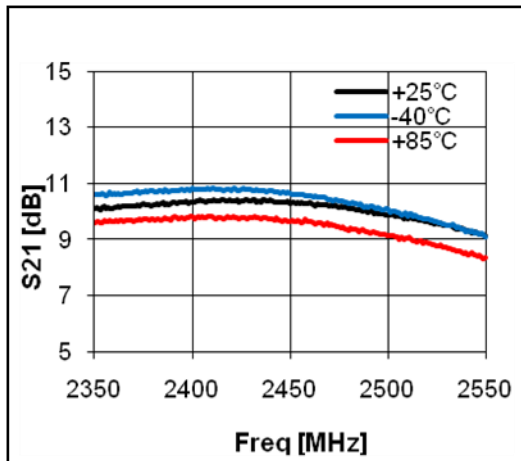
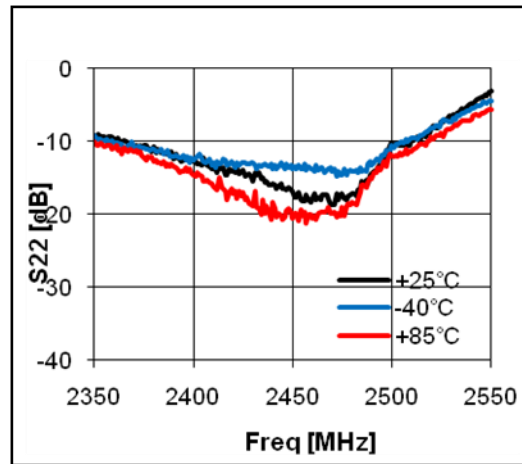
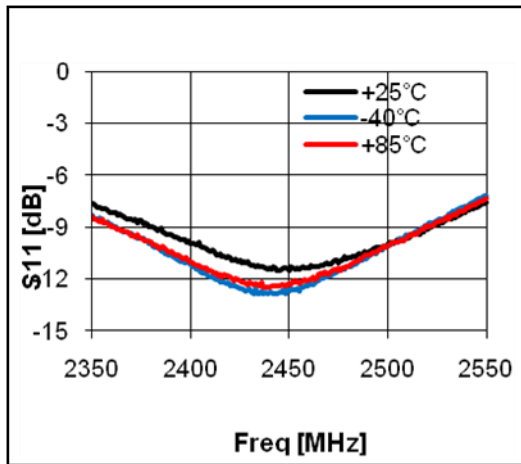

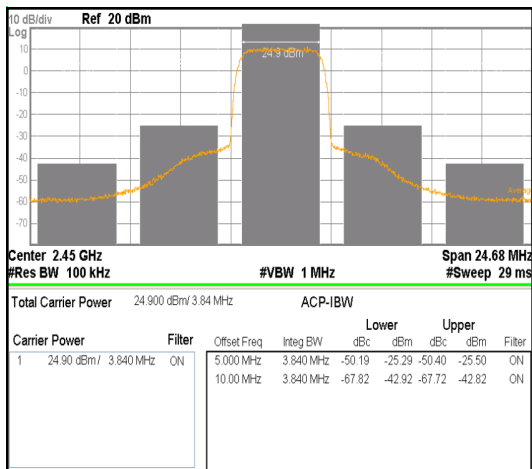
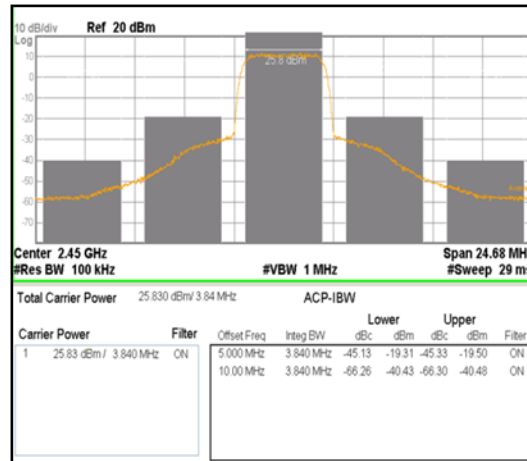
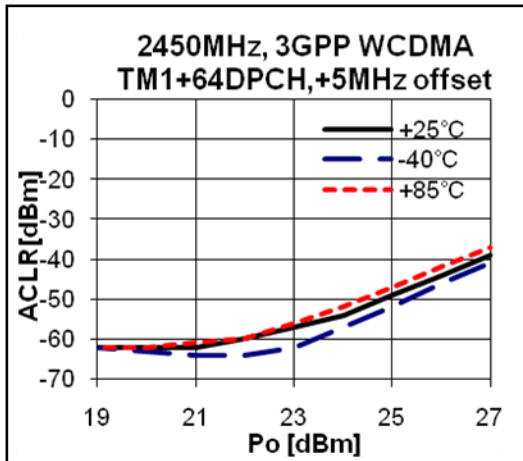

Package Outline Dimension

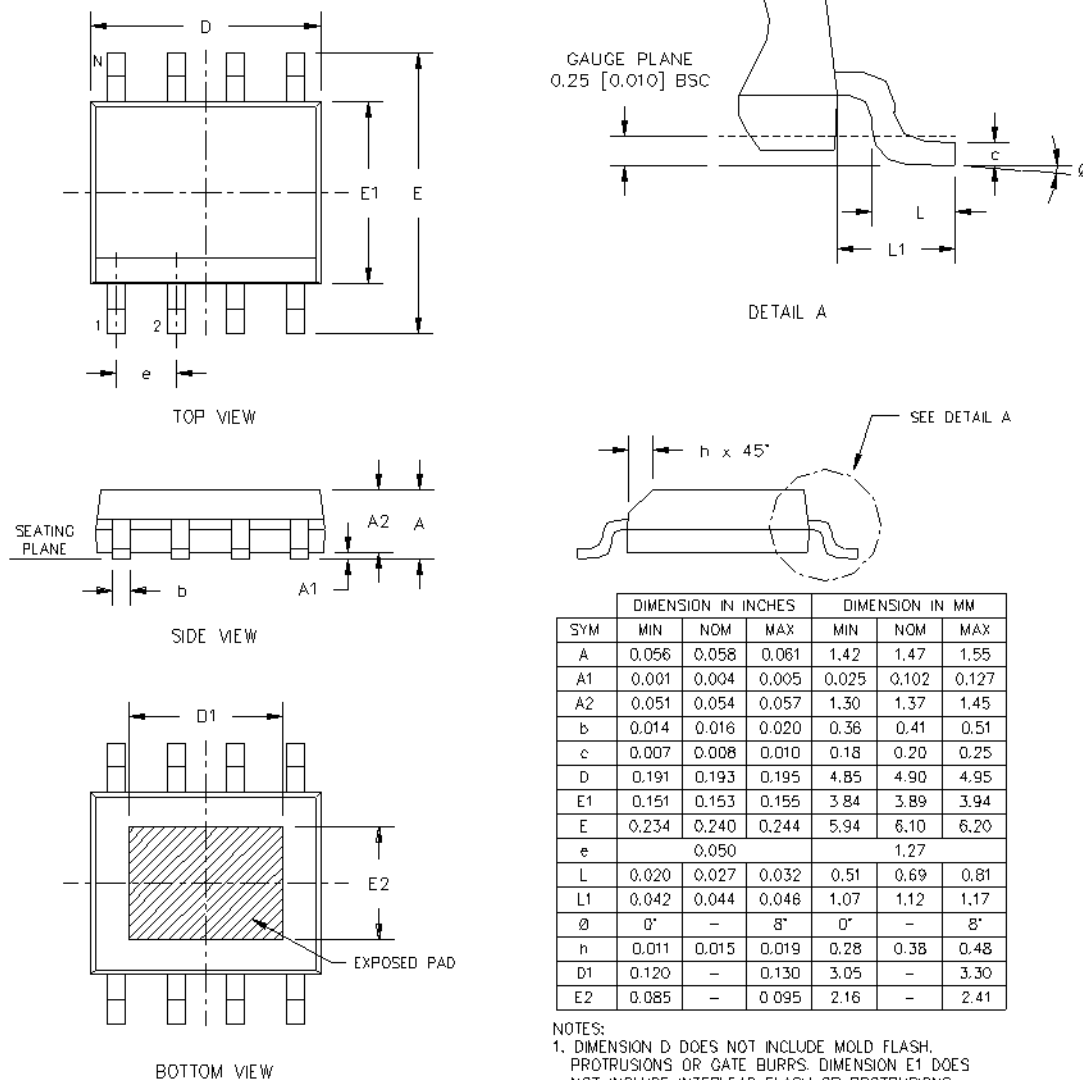

- NOTES:
1. DIMENSION D DOES NOT INCLUDE MOLD FLASH, PROTRUSIONS OR GATE BURRS. DIMENSION E1 DOES NOT INCLUDE INTERLEAD FLASH OR PROTRUSIONS.
 2. COPLANARITY APPLIES TO THE TERMINALS. COPLANARITY SHALL NOT EXCEED 0.003" [0.08 mm]
 3. BASED FROM JEDEC MS-012 VARIATION AA.

Suggested PCB Land Pattern and PAD Layout

PCB Land Pattern

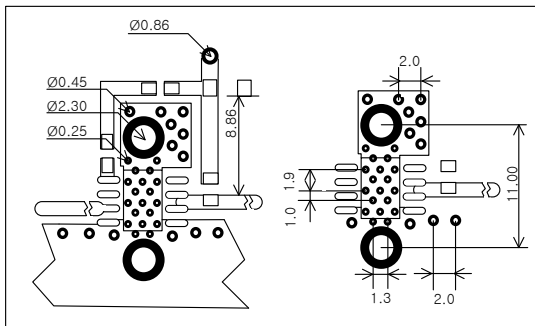

Note : All dimension are in millimeters

PCB lay out _on BeRex website

PCB Mounting

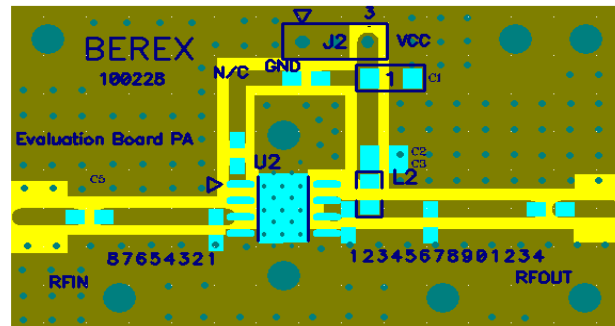

Package Marking

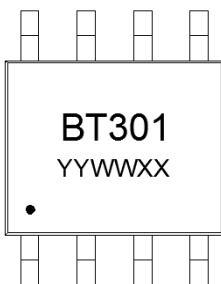

Pin 1

YY = Year, WW = Working Week,
XX = Wafer No.

Tape & Reel

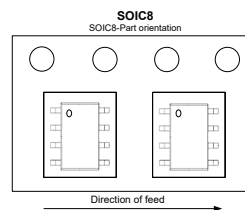

Packaging information:

Tape Width (mm): 12
Reel Size (inches): 7
Device Cavity Pitch (mm): 8
Devices Per Reel: 1000

Lead plating finish

100% Tin Matte finish

(All BeRex products undergoes a 1 hour, 150 degree C, Anneal bake to eliminate thin whisker growth concerns.)

MSL / ESD Rating

ESD Rating:	Class 1B
Value:	Passes <1000V
Test:	Human Body Model (HBM)
Standard:	JEDEC Standard JESD22-A114
MSL Rating:	Level 3 at +260°C convection reflow
Standard:	JEDEC Standard J-STD-020



Proper ESD procedures should be followed when handling this device.

RoHS Compliance

This part is compliant with Restrictions on the Use of Certain Hazardous Substances in Electrical and Electronic Equipment (RoHS) Directive 2011/65/EU as amended by Directive 2015/863/EU.



This product also is compliant with a concentration of the Substances of Very High Concern (SVHC) candidate list which are contained in a quantity of less than 0.1%(w/w) in each components of a product and/or its packaging placed on the European Community market by the BeRex and Suppliers.

NATO CAGE code:

2	N	9	6	F
----------	----------	----------	----------	----------

Looking for pricing, stock, or lifecycle information?

Click below to explore more details on WIN SOURCE:

-  [View BT301 on WIN SOURCE](#)
-  [BeRex Corporation Information](#)

Optimize Your Supply Chain with WIN SOURCE Solutions

-  Global Sourcing Solution
-  Obsolete Management
-  Cost Control Management
-  Shortage Management
-  Alternative Solution
-  Excess Inventory Management