

## 50-4000 MHz Wideband Low Noise Amplifier

### Device Features

- This can be operated at Vd of 3.0V
- N.F = 0.78 dB @ 1850MHz at Demo board
- 31.5 dBm Output IP3 at 0dBm/tone at 1850MHz
- 15.6 dB Gain at 1850MHz
- 17.7 dBm P1dB at 1850 MHz
- Green/RoHS2 Compliant SOT-363 SMT Package

### Part Marking (XX:Wafer number)

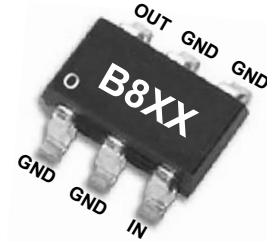

Pin Description	
RF IN	3
RF OUT	6
GND	1,2,4,5

### Product Description

BeRex's BL083 is a high performance LNA, based on GaAs material with E-pHEMT process and packaged in a RoHS2-compliant with SOT-363 Surface mount package. It is designed for use where low noise and high linearity are required and features low noise and high OIP3 with low current at wideband frequency. It requires a few external matching components. All devices are 100% RF/DC tested and classified as HBM ESD Class 1B.

### Applications

- Base station Infrastructure/RFID
- Commercial/Industrial/Military wireless system
- LTE / WCDMA /CDMA Wireless Infrastructure

### Applications Circuit

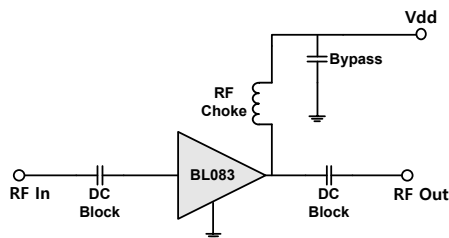

\*External matching circuit : refer to the page 4 to 13

### Electrical Specifications

Device performance \_ measured on a BeRex evaluation board at 25°C, Vd=3V, 50 Ω system.

Parameter	Conditions	Min	Typ	Max	Unit
Operational Frequency Range		50		4000	MHz
Test Frequency			1850		MHz
Gain		14.1	15.6		dB
Input Return Loss			-12.1		dB
Output Return Loss			-18.2		dB
Output IP3	0 dBm / tone , Δf=1 MHz	28.5	31.5		dBm
Output P1dB		16.7	17.7		dBm
Noise Figure			0.78	0.98	dB

\* NF : Losses on input and output transmission lines on PCB are not de-embedded.

### Recommended Operating Conditions

Parameter	Min	Typ	Max	Unit
Bandwidth	50		4000	MHz
I <sub>C</sub> @ (V <sub>C</sub> = 3V)	34	42	50	mA
V <sub>C</sub>	2.85	3	3.15	V
R <sub>TH</sub>		95		°C/W
Operating Case Temperature	-40		+105	°C

Electrical specifications are measured at specified test conditions.

Specifications are not guaranteed over all recommended operating conditions.

### Absolute Maximum Ratings

Parameter	Rating	Unit
Storage Temperature	-55 to +155	°C
Junction Temperature	+165	°C
Supply Voltage	+5	V
Supply Current	100	mA
Input RF Power	15	dBm

Operation of this device above any of these parameters may result in permanent damage.

## 50-4000 MHz Wideband Low Noise Amplifier

### Typical Performance (Vd=3.0V, Id=42mA, T=25°C)

Parameter	Frequency					Unit
	900	1850	2140	2650	3500	MHz
Gain	20.4	15.6	14.3	13.3	10.6	dB
S11	-18.7	-12.1	-13.3	-16.8	-18.3	dB
S22	-19.5	-18.2	-15.5	-15.9	-16.0	dB
OIP3	30.0	31.5	31.5	32.5	32.2	dBm
P1dB	17.9	17.7	17.7	17.4	17.6	dBm
Noise Figure	0.78	0.78	0.95	0.95	1.16	dB

\* NF : Losses on input and output transmission lines on PCB are not de-embedded.

### V-I Characteristics

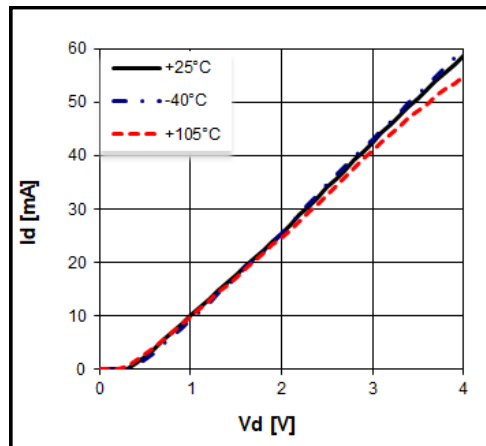

### BeRex SOT-363 Evaluation Board

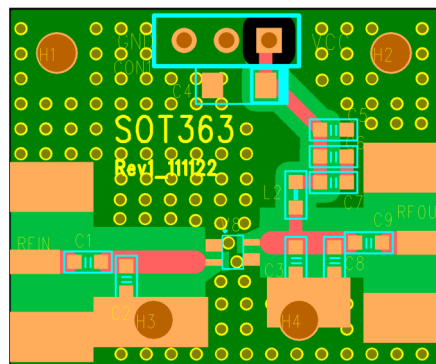

\*Dielectric constant \_ 4.2 \*RF pattern width 52mil \*31mil thick FR4 PCB

\*Without vias under device degrade device performance.

# 50-4000 MHz Wideband Low Noise Amplifier

## Typical Device Data

S-parameters ( $V_d=3.0V, I_d=42mA, T=25^\circ C$ )

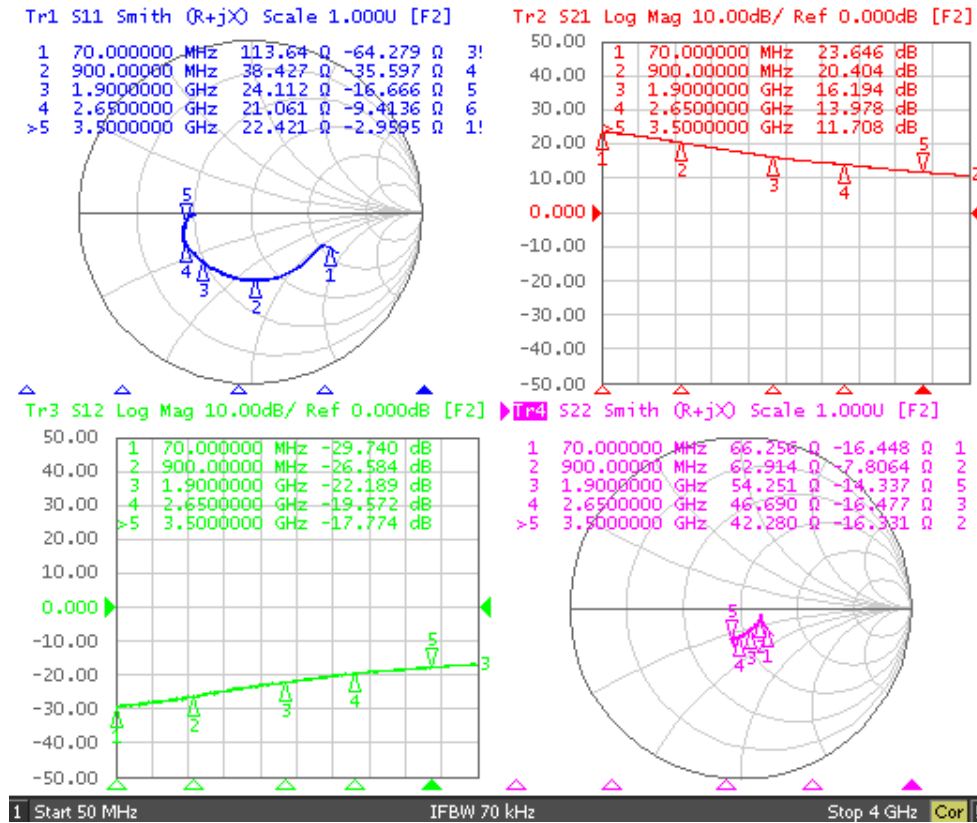

## S-Parameter

( $V_d=3.0V, I_d=42mA, T=25^\circ C$ , calibrated to device leads)

Freq [MHz]	S11 [Mag]	S11 [Ang]	S21 [Mag]	S21 [Ang]	S12 [Mag]	S12 [Ang]	S22 [Mag]	S22 [Ang]
100	0.48	-24.14	14.85	167.26	0.035	17.00	0.16	-34.16
500	0.42	-55.40	12.82	143.16	0.039	23.01	0.13	-19.03
1000	0.39	-93.60	9.94	117.62	0.050	37.25	0.13	-31.43
1500	0.40	-119.98	7.76	98.82	0.067	41.61	0.14	-51.45
2000	0.40	-137.73	6.13	84.27	0.083	42.68	0.14	-70.75
2500	0.42	-150.55	5.22	72.86	0.100	42.55	0.17	-86.74
3000	0.41	-164.20	4.44	59.35	0.115	36.72	0.17	-99.62
3500	0.38	-171.62	3.84	48.10	0.129	32.56	0.19	-104.82
4000	0.33	-177.45	3.39	33.95	0.143	22.40	0.23	-95.63

## 50-4000 MHz Wideband Low Noise Amplifier

### Application Circuit: 900 MHz

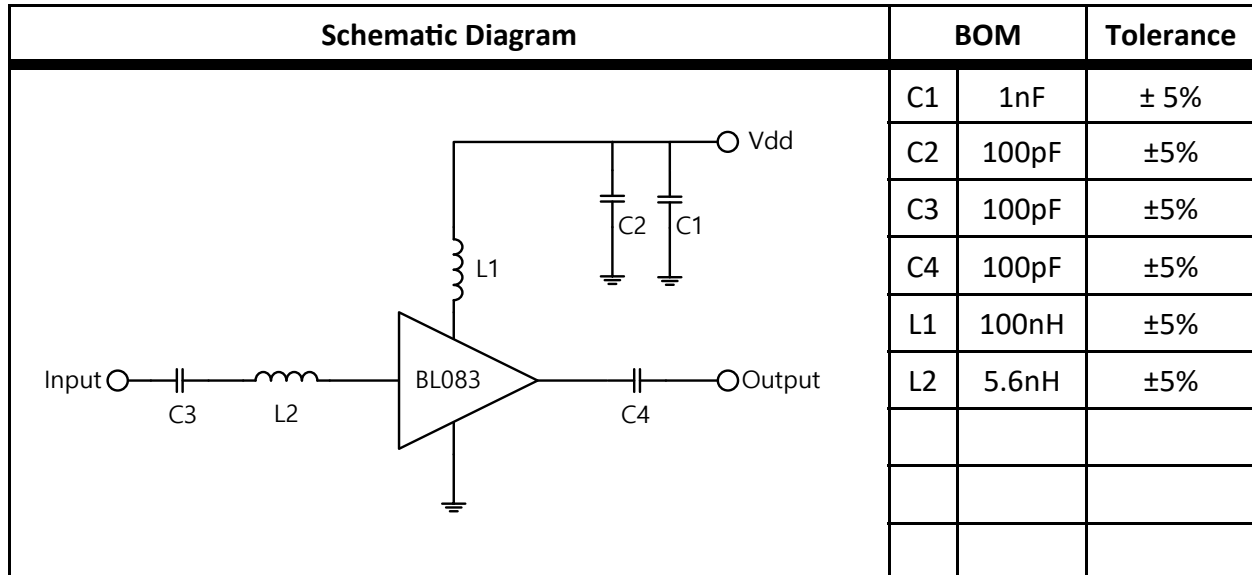

### Typical Performance ( $V_d=3.0V$ , $I_d=42mA$ , $T=25^\circ C$ )

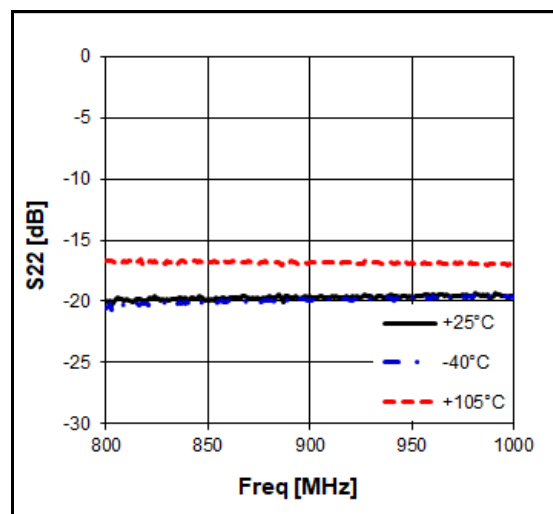
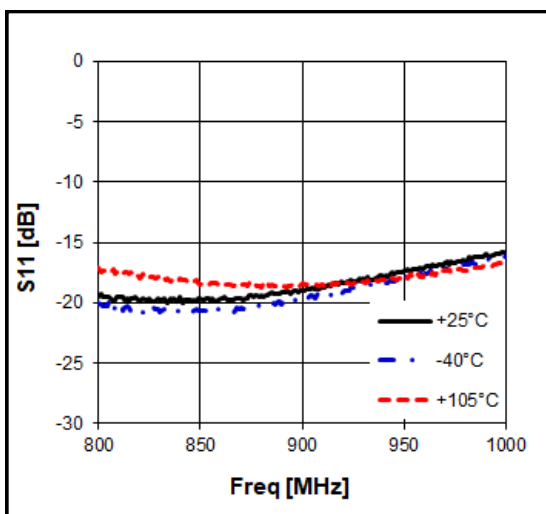

## 50-4000 MHz Wideband Low Noise Amplifier

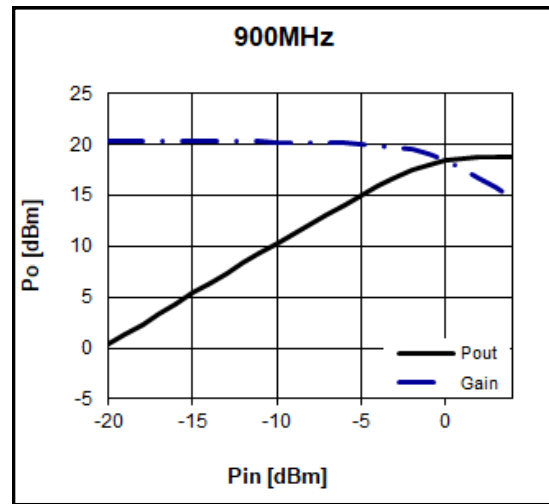
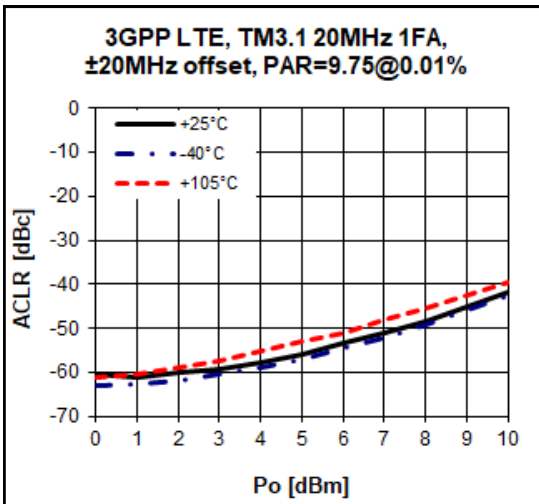
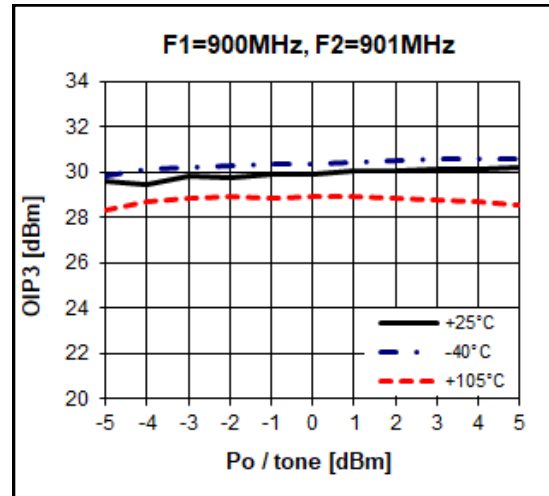
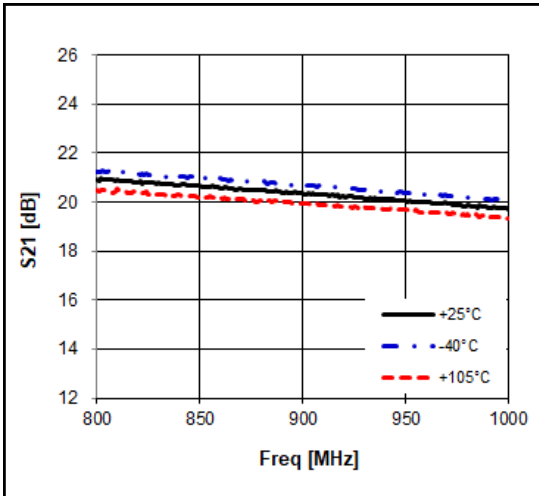

### Noise Figure Temperature Performance

(V<sub>d</sub> = 3V, I<sub>d</sub> = 42mA)

Freq	MHz	900	1850	2140	2650	3500
Temp [°C]	-40	0.69	0.67	0.81	0.79	1.04
	25	0.78	0.78	0.95	0.95	1.16
	105	0.84	0.84	1.04	1.12	1.43

\* NF : Losses on input and output transmission lines on PCB are not de-embedded.

## 50-4000 MHz Wideband Low Noise Amplifier

### Application Circuit: 1850 MHz

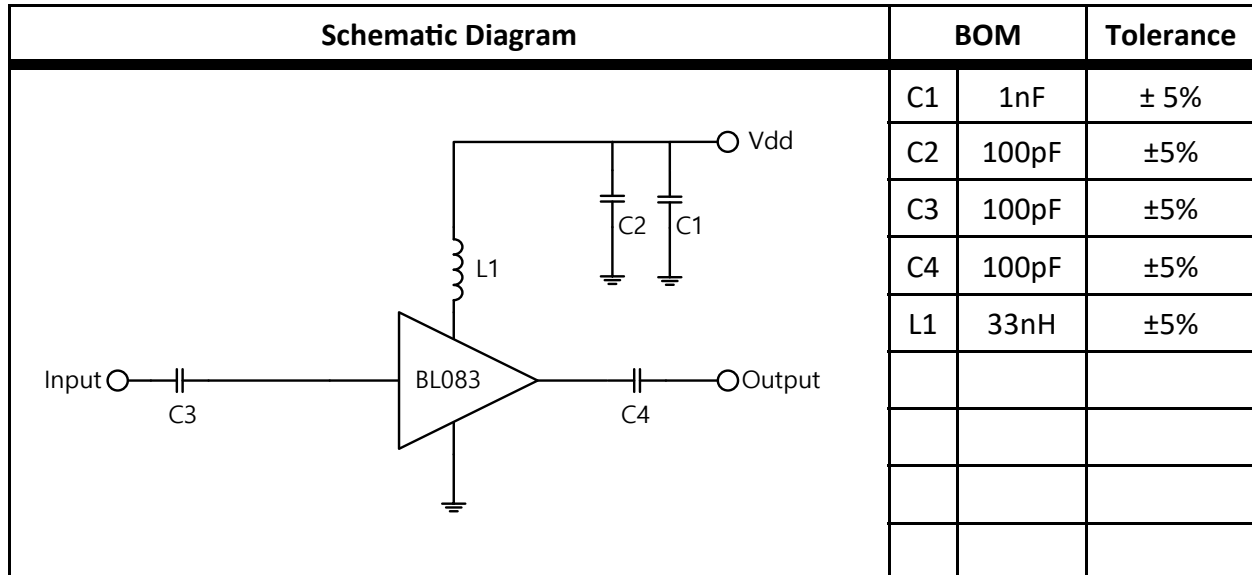

### Typical Performance ( $V_d=3.0V$ , $I_d=42mA$ , $T=25^\circ C$ )

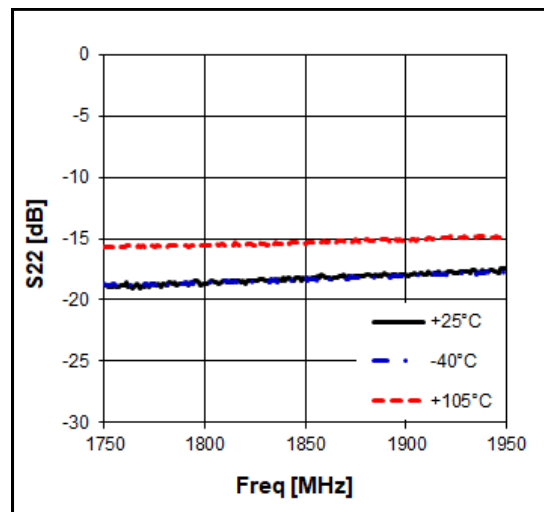
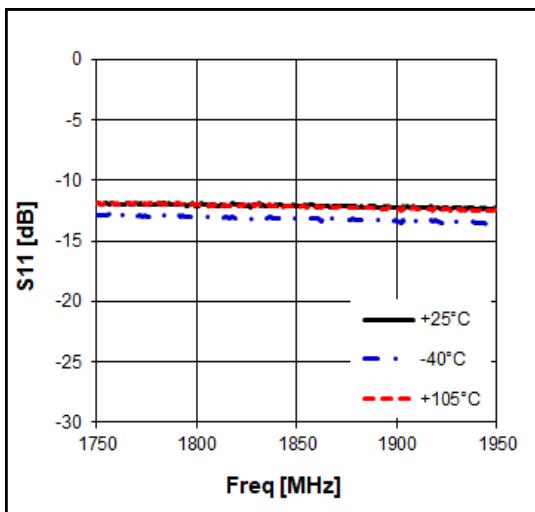

## 50-4000 MHz Wideband Low Noise Amplifier

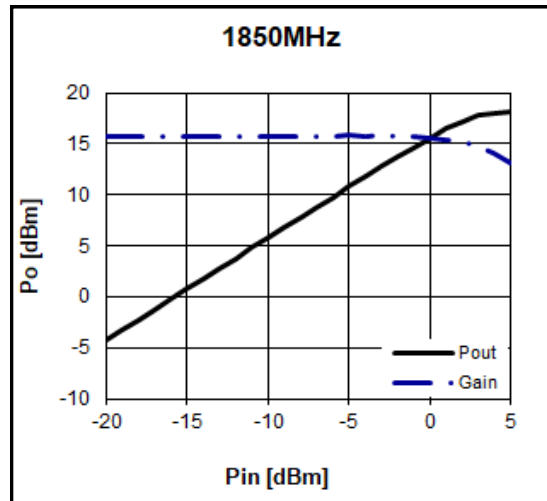
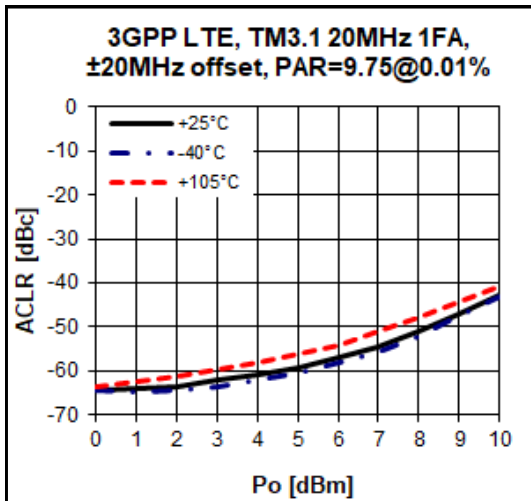
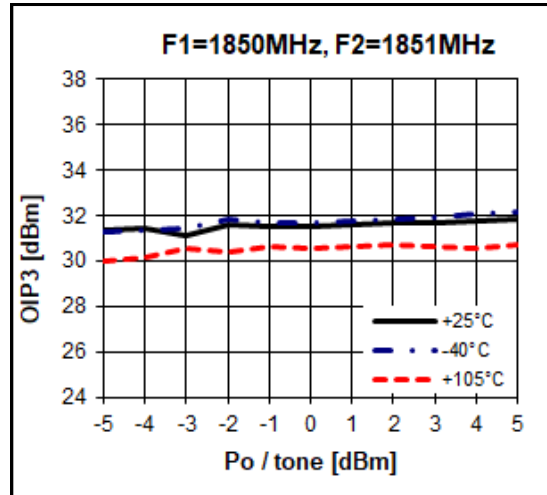
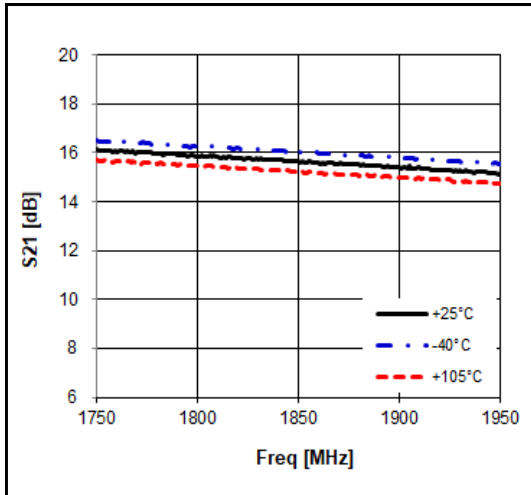

### Noise Figure Temperature Performance

(Vd = 3V, Id = 42mA)

Freq	MHz	900	1850	2140	2650	3500
Temp [°C]	-40	0.69	0.67	0.81	0.79	1.04
	25	0.78	0.78	0.95	0.95	1.16
	105	0.84	0.84	1.04	1.12	1.43

\* NF : Losses on input and output transmission lines on PCB are not de-embedded.

## 50-4000 MHz Wideband Low Noise Amplifier

### Application Circuit: 2140 MHz

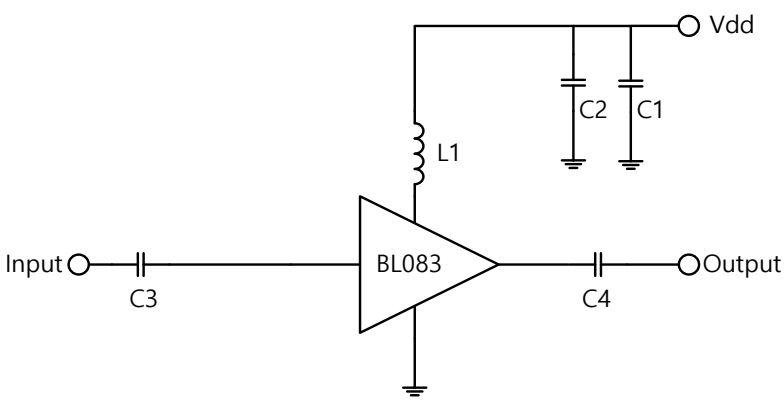
Schematic Diagram	BOM	Tolerance	
	C1	1nF	± 5%
	C2	100pF	±5%
	C3	100pF	±5%
	C4	100pF	±5%
	L1	33nH	±5%

### Typical Performance ( $V_d=3.0V$ , $I_d=42mA$ , $T=25^\circ C$ )

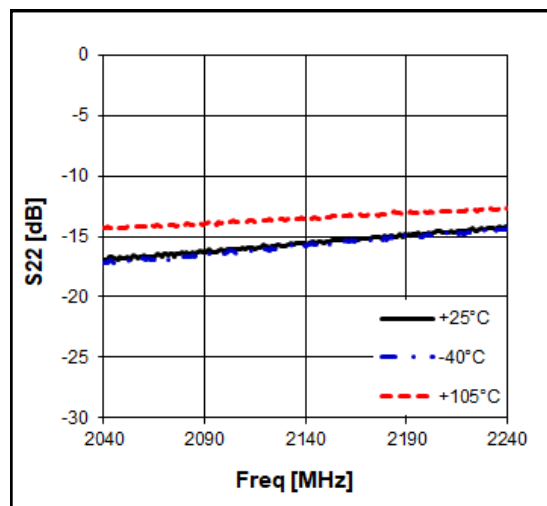
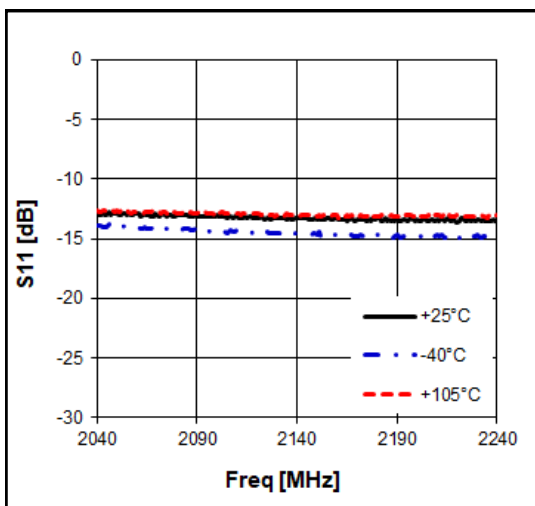

## 50-4000 MHz Wideband Low Noise Amplifier

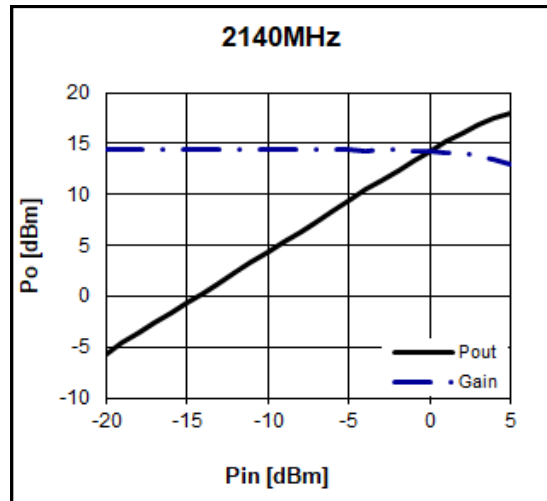
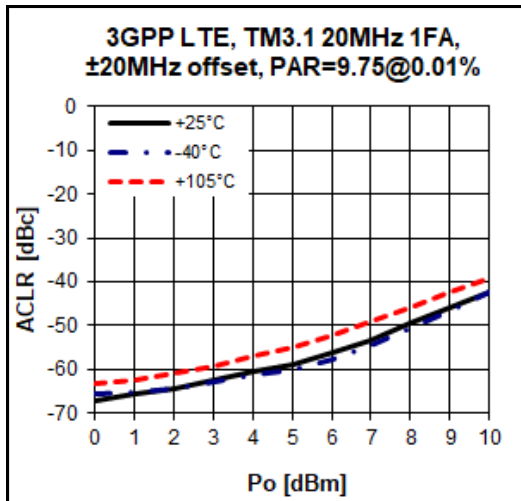
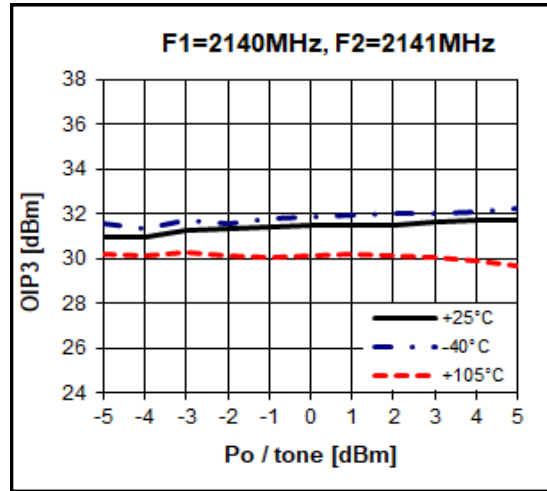
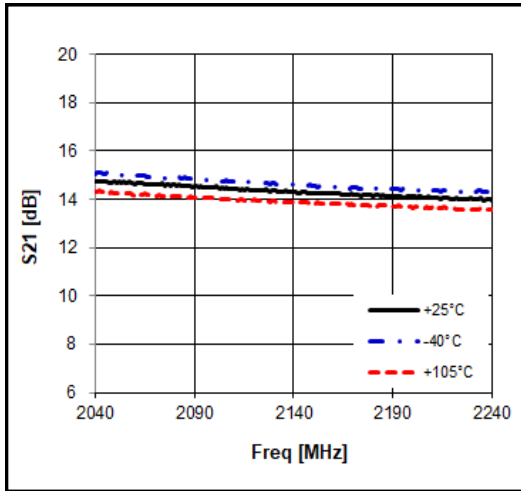

### Noise Figure Temperature Performance

(Vd = 3V, Id = 42mA)

Freq	MHz	900	1850	2140	2650	3500
Temp [°C]	-40	0.69	0.67	0.81	0.79	1.04
	25	0.78	0.78	0.95	0.95	1.16
	105	0.84	0.84	1.04	1.12	1.43

\* NF : Losses on input and output transmission lines on PCB are not de-embedded.

## 50-4000 MHz Wideband Low Noise Amplifier

### Application Circuit: 2650 MHz

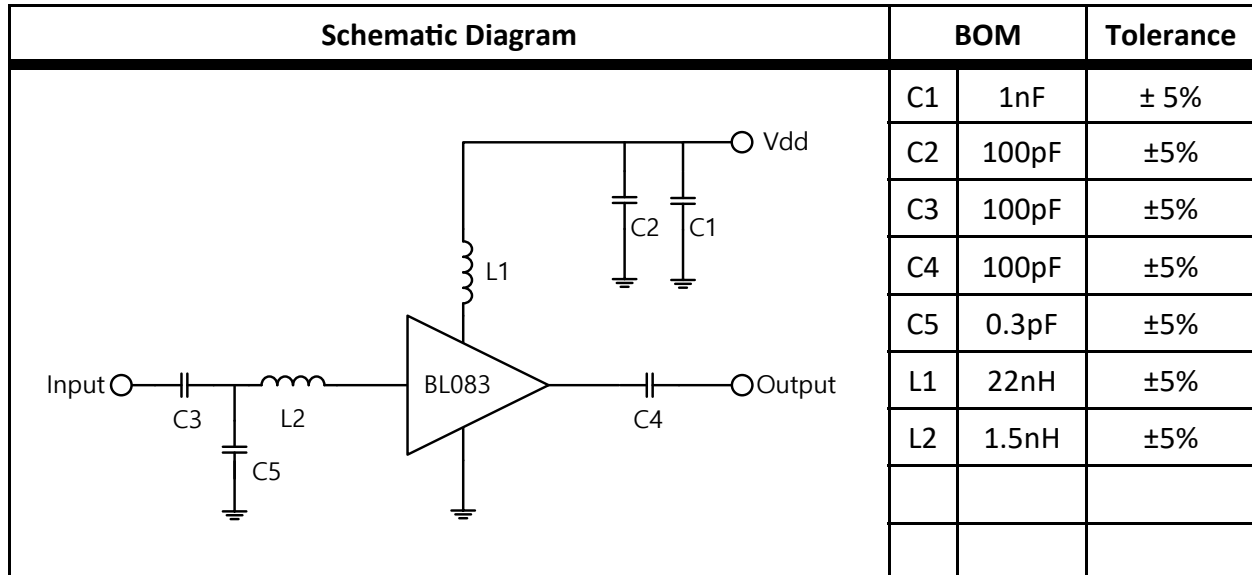

### Typical Performance ( $V_d=3.0V$ , $I_d=42mA$ , $T=25^\circ C$ )

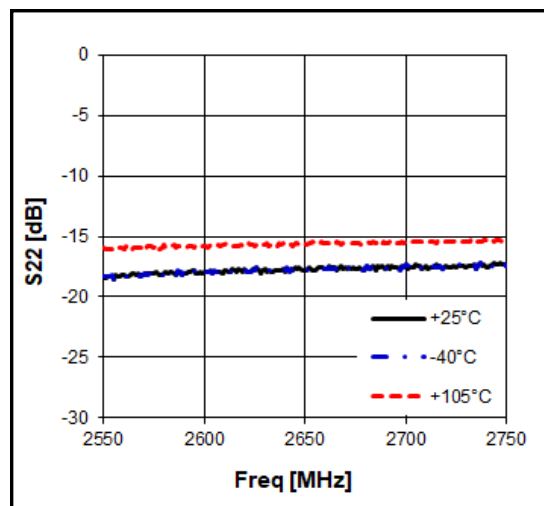
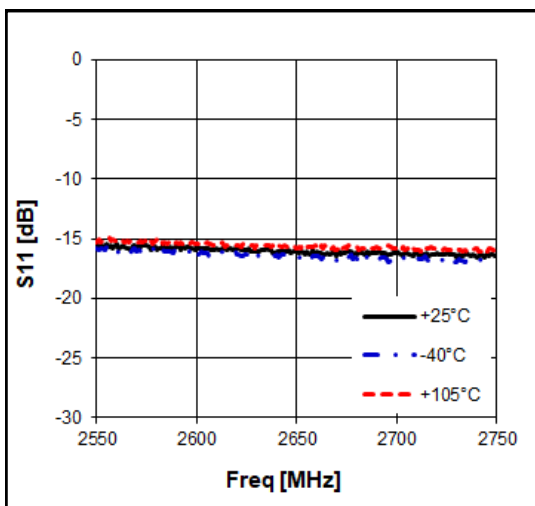

## 50-4000 MHz Wideband Low Noise Amplifier

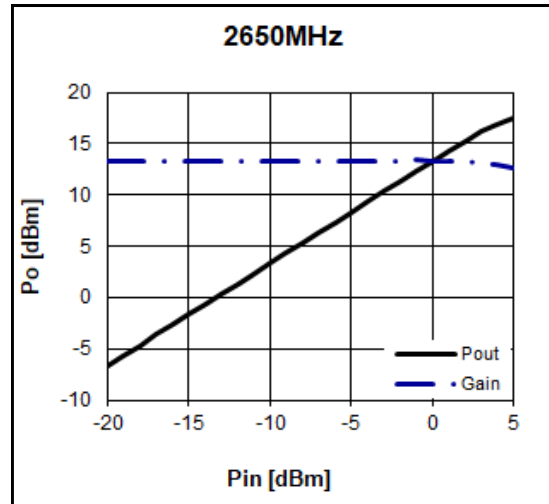
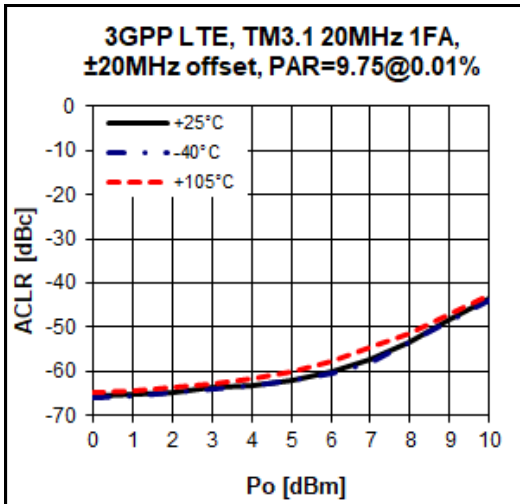
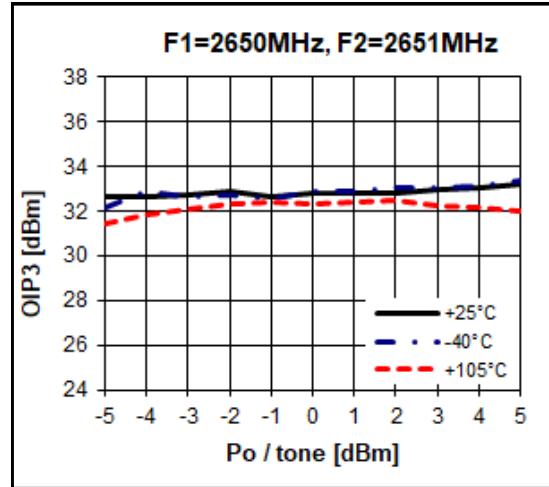
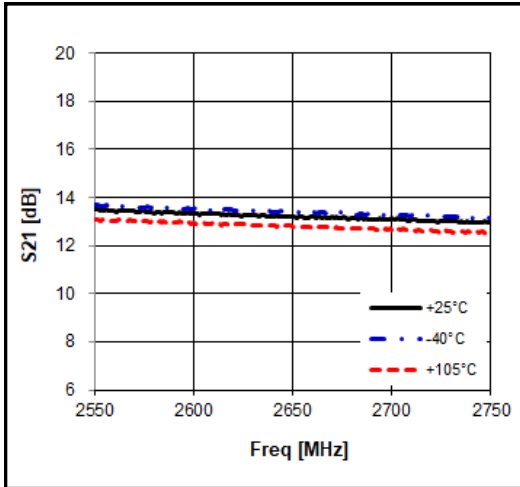

### Noise Figure Temperature Performance

(Vd = 3V, Id = 42mA)

Freq	MHz	900	1850	2140	2650	3500
Temp [°C]	-40	0.69	0.67	0.81	0.79	1.04
	25	0.78	0.78	0.95	0.95	1.16
	105	0.84	0.84	1.04	1.12	1.43

\* NF : Losses on input and output transmission lines on PCB are not de-embedded.

## 50-4000 MHz Wideband Low Noise Amplifier

### Application Circuit: 3500 MHz

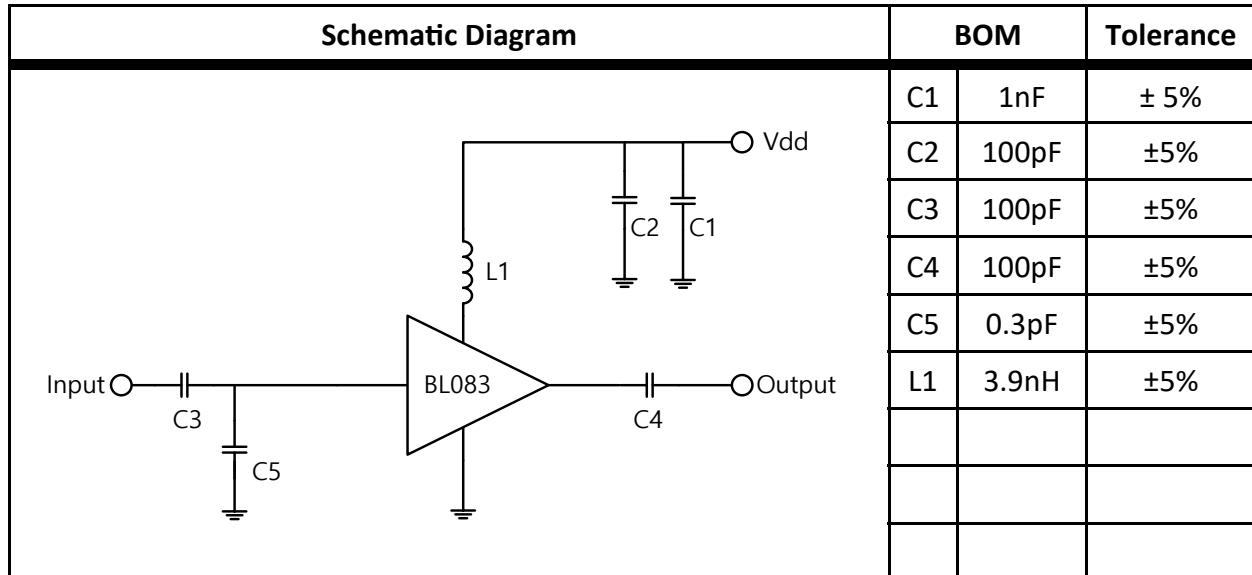

### Typical Performance ( $V_d=3.0V$ , $I_d=42mA$ , $T=25^\circ C$ )

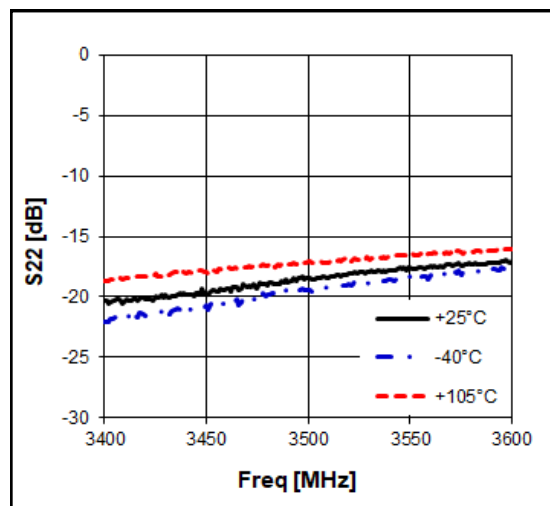
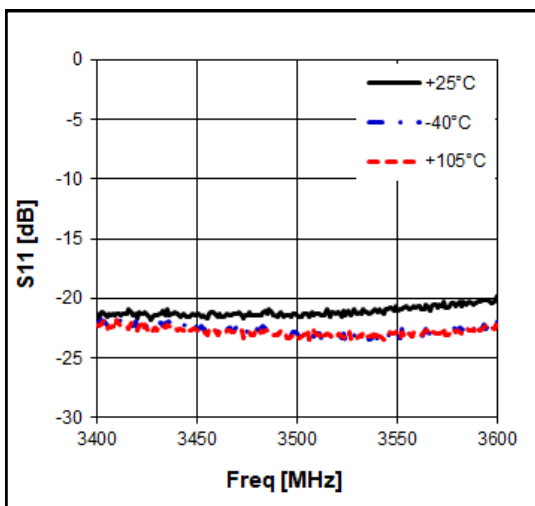

## 50-4000 MHz Wideband Low Noise Amplifier

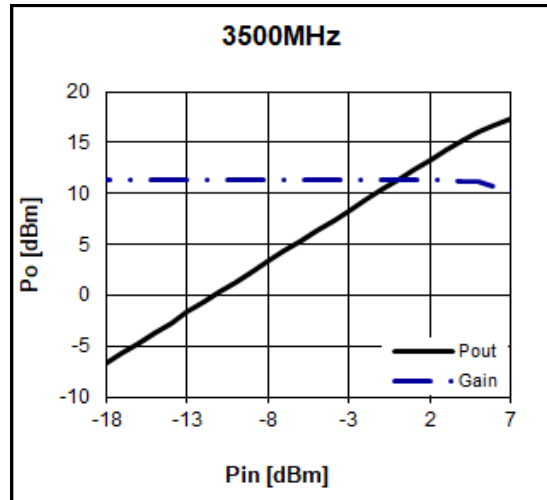
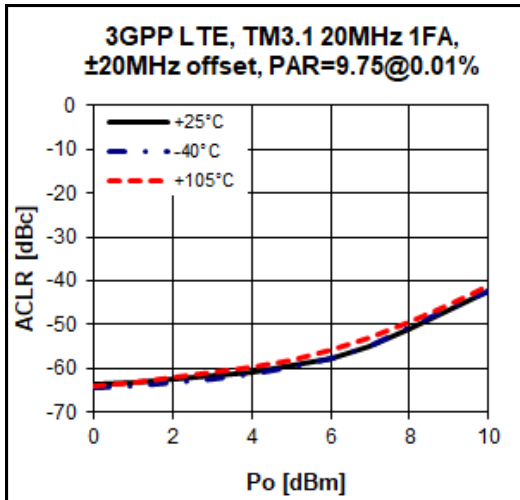
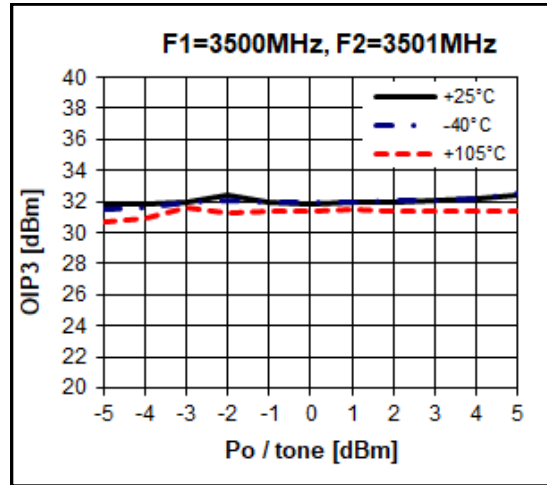
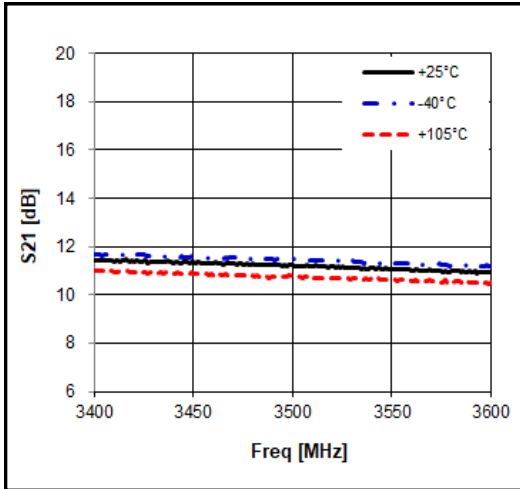

### Noise Figure Temperature Performance

(Vd = 3V, Id = 42mA)

Freq	MHz	900	1850	2140	2650	3500
Temp [°C]	-40	0.69	0.67	0.81	0.79	1.04
	25	0.78	0.78	0.95	0.95	1.16
	105	0.84	0.84	1.04	1.12	1.43

\* NF : Losses on input and output transmission lines on PCB are not de-embedded.

# 50-4000 MHz Wideband Low Noise Amplifier

## Package Outline Dimension

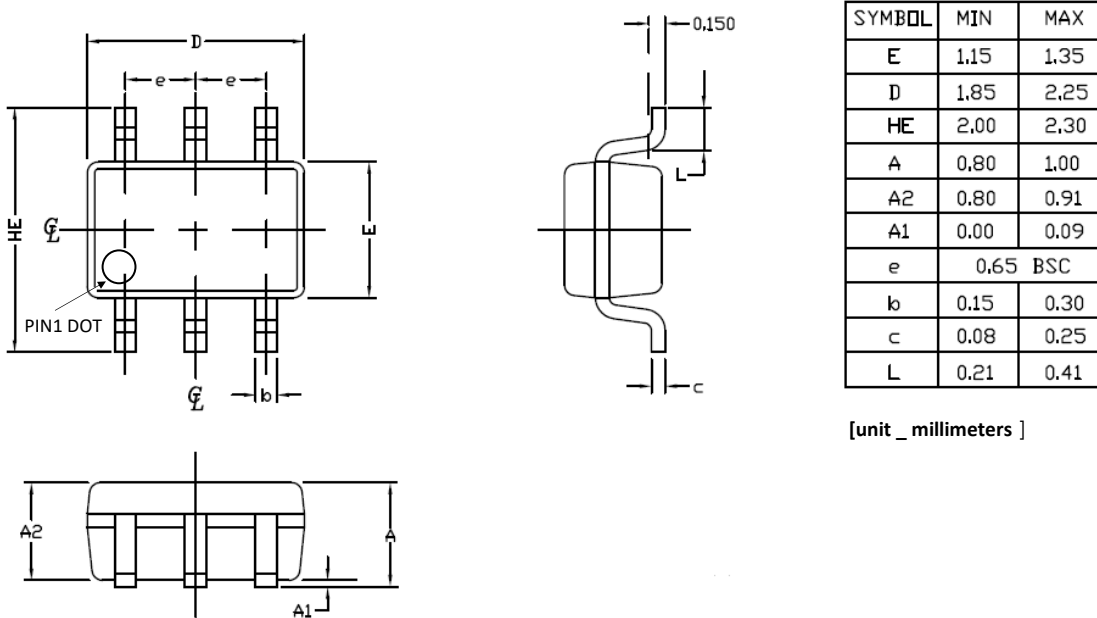

## Suggested PCB Land Pattern and PAD Layout

### PCB Land Pattern

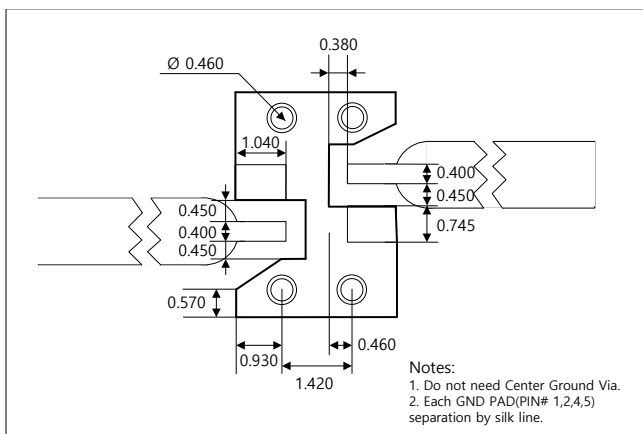

### PCB Mounting

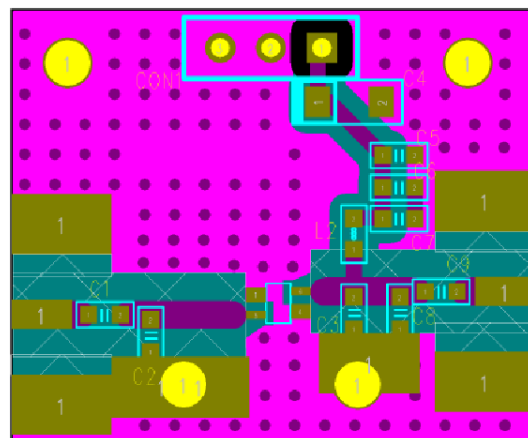

Note : All dimension \_ millimeters

PCB lay out \_ on BeRex website

## 50-4000 MHz Wideband Low Noise Amplifier

### Package Marking

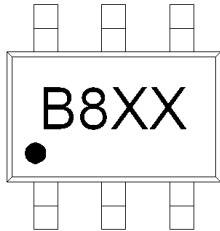

Pin 1

XX = Wafer No.

### Tape & Reel

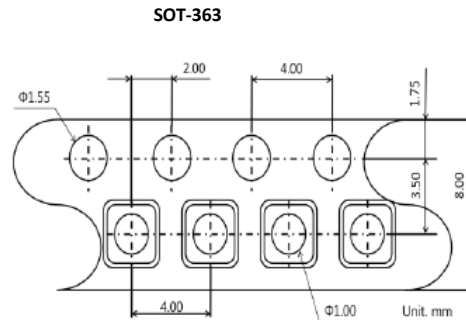

Packaging information:

- Tape Width (mm): 8
- Reel Size (inches): 7
- Device Cavity Pitch (mm): 4
- Devices Per Reel: 3000

### Lead plating finish

100% Tin Matte finish

(All BeRex products undergoes a 1 hour, 150 degree C, Anneal bake to eliminate thin whisker growth concerns.)

### MSL / ESD Rating

<b>ESD Rating:</b>	Class 1B
<b>Value:</b>	Passes <1000V
<b>Test:</b>	Human Body Model (HBM)
<b>Standard:</b>	JEDEC Standard JESD22-A114
<b>MSL Rating:</b>	Level 1 at +260°C convection reflow
<b>Standard:</b>	JEDEC Standard J-STD-020



Proper ESD procedures should be followed when handling this device.

## 50-4000 MHz Wideband Low Noise Amplifier

---

### RoHS Compliance

This part is compliant with Restrictions on the Use of Certain Hazardous Substances in Electrical and Electronic Equipment (RoHS) Directive 2011/65/EU as amended by Directive 2015/863/EU.



This product also is compliant with a concentration of the Substances of Very High Concern (SVHC) candidate list which are contained in a quantity of less than 0.1%(w/w) in each components of a product and/or its packaging placed on the European Community market by the BeRex and Suppliers.

### NATO CAGE code:

2	N	9	6	F
---	---	---	---	---

## Looking for pricing, stock, or lifecycle information?

Click below to explore more details on WIN SOURCE:

-  [View BL083 on WIN SOURCE](#)
-  [BeRex Corporation](#) Information

## Optimize Your Supply Chain with WIN SOURCE Solutions

-  Global Sourcing Solution
-  Obsolete Management
-  Cost Control Management
-  Shortage Management
-  Alternative Solution
-  Excess Inventory Management