

### Device Features

- Single Fixed 3V supply
- No Dropping Resistor Required
- No matching circuit needed
- Green/RoHS2 compliant SOT-363 package
- Application: Driver Amplifier, Cellular, PCS, GSM, UMTS, WCDMA, Wireless Data

### Product Description

BeRex's BGS3 is a high SiGe HBT MMIC amplifier, internally matched to 50 Ohms without the need for external components. Designed to run directly from a 3V supply. The BGS3 is designed for high linearity 3V gain block applications. It is packaged in a RoHS2-compliant with SOT-363 surface mount package.

### Applications

- Driver Amplifier
- Cellular, PCS, GSM, UMTS, WCDMA
- Military wireless system

### Applications Circuit

Application Circuit Values Example				
Freq.	30~700MHz	0.7 ~ 3GHz	3 ~ 4GHz	4 ~ 5GHz
C1/C2	2nF	100pF	10pF	10pF
L1 (1608 Ind.)	820nH	56nH	12nH	10nH

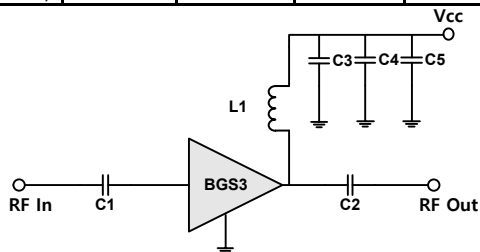

\*C1, C2, C3 =100 pF ± 5%; C4 = 1 nF ± 5%; C5 = 10uF; \*\*L1 = 56nH

\*\*Less than 56nH improves RF performance at over 0.9GHz.

\*820nH or higher value L1 improves RF performance at under 900MHz.

\*Optimum value of L1 may vary with board design.

\*C1,C2=2nF, L1=820nH for 50MHz application.

\*C1,C2=10pF, L1=12nH for 3.5GHz application.

### Part Marking (XX:Wafer number)

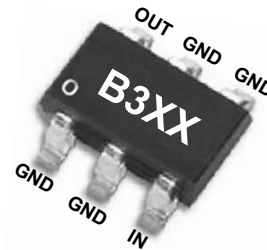

Pin Description	
RF IN	3
RF OUT	6
GND	1,2,4,5

### Electrical Specifications

Device performance \_ measured on a BeRex evaluation board at 25°C, Vc=3V, 50 Ω system.

Parameter	Conditions	Min	Typ	Max	Unit
Operational Frequency Range		30		5000	MHz
Test Frequency			900		MHz
Gain		23.9	25.4		dB
Input Return Loss			-17.0		dB
Output Return Loss			-14.0		dB
Output IP3	0 dBm / tone , Δf=1 MHz	27.5	30.5		dBm
Output P1dB		16.4	17.4		dBm
Noise Figure			1.7		dB

### Recommended Operating Conditions

Parameter	Min	Typ	Max	Unit
Bandwidth	30		5000	MHz
Ic @ (Vc = 3 V)	40	55	66	mA
Vc	2.7	3.0	3.3	V
dG/dT		-0.006		
R <sub>TH</sub>		130		°C/W
Operating Case Temperature	-40		+105	°C

Electrical specifications are measured at specified test conditions.

Specifications are not guaranteed over all recommended operating conditions.

### Absolute Maximum Ratings

Parameter	Rating	Unit
Storage Temperature	-55 to +155	°C
Junction Temperature	170	°C
Supply Voltage	+3.7	V
Supply Current	120	mA
Input RF Power	12	dBm

Operation of this device above any of these parameters may result in permanent damage.

**30-5000 MHz SILICON GERMANIUM Gain Block**

 Typical Performance ( $V_c = 3.0V$ ,  $I_c = 55mA$ ,  $T = 25^\circ C$ )

Freq	MHz	30	50	70	900	1900	2140	2450	2650	3500	4500
S21	dB	28.8	28.6	28	25.4	21.6	20.8	20	19.5	18	16.8
S11	dB	-13	-16	-17	-17	-17	-18	-20	-22	-15.0	-13.5
S22	dB	-15	-15	-14	-14	-14	-14	-16	-17	-15.9	-14.8
P1	dBm	16	16.2	16.7	17.4	16.9	16	16	15.9	14.2	13.5
OIP3	dBm	30	31	30.5	30.5	30.5	29	28.5	28.5	27	25
NF	dB	1.9	1.6	1.8	1.7	1.8	1.9	1.9	2	2.07	2.28

 Typical Performance ( $V_c = 2.7V$ ,  $I_c = 34mA$ ,  $T = 25^\circ C$ )

Freq	MHz	30	50	70	900	1900	2140	2450	2650	3500	4500
S21	dB	27.9	27.3	27.1	24.7	21.1	20.5	19.6	19.1	17.4	16.3
S11	dB	-12.1	-16	-19.4	-20.7	-17.8	-18.3	-18.7	-17.8	-12.2	-11
S22	dB	-24	-36	-32.4	-19	-14.7	-14.8	-15.9	-16.9	-13.8	-14.4
P1	dBm	14.2	14.2	14.7	14.8	15.2	14.5	14.8	15.2	13.4	12.5
OIP3	dBm	26.6	28.7	27.9	26.4	26.7	26.3	26.5	27.1	25.1	24.3
NF	dB	1.82	1.52	1.64	1.6	1.74	1.77	1.83	1.88	2.02	2.22

 Typical Performance ( $V_c = 2.8V$ ,  $I_c = 40mA$ ,  $T = 25^\circ C$ )

Freq	MHz	30	50	70	900	1900	2140	2450	2650	3500	4500
S21	dB	28.6	28	27.7	25.1	21.4	20.7	19.9	19.3	17.7	16.5
S11	dB	-13.1	-17.1	-20.2	-20.4	-17.7	-18.4	-19.5	-19	-13.4	-12
S22	dB	-33	-23.1	-21.4	-17.5	-15.1	-15.4	-16.6	-18	-14.7	-14.6
P1	dBm	14.9	14.8	15.3	15.6	15.7	15	15.1	15.5	13.7	12.9
OIP3	dBm	27.7	29.5	28.8	28	28.2	27.7	27.8	28.1	25.8	24.4
NF	dB	1.85	1.54	1.65	1.61	1.75	1.8	1.85	1.9	2.02	2.22

 Typical Performance ( $V_c = 2.9V$ ,  $I_c = 47mA$ ,  $T = 25^\circ C$ )

Freq	MHz	30	50	70	900	1900	2140	2450	2650	3500	4500
S21	dB	29.1	28.5	28.2	25.4	21.6	20.9	20	19.5	17.8	16.6
S11	dB	-13.4	-16.6	-18.3	-18.8	-17.1	-17.9	-19.7	-19.6	-14.2	-12.8
S22	dB	-22.3	-18	-17.6	-15.9	-15.4	-15.7	-17.1	-18.7	-15.3	-14.8
P1	dBm	15.5	15.5	16.1	17.2	16.7	15.9	15.5	15.9	14.0	13.3
OIP3	dBm	29.1	30.6	30.4	29.5	29.5	29	28.6	29.0	26.5	24.7
NF	dB	1.9	1.57	1.67	1.64	1.77	1.81	1.87	1.92	2.02	2.23

## 30-5000 MHz SILICON GERMANIUM Gain Block

Typical Performance ( $V_c = 3.1V$ ,  $I_c = 65mA$ ,  $T = 25^\circ C$ )

Freq	MHz	30	50	70	900	1900	2140	2450	2650	3500	4500
S21	dB	29.8	29.1	28.8	25.8	21.9	21.1	20.2	19.7	18.1	16.8
S11	dB	-13	-14.6	-15.2	-16.4	-16.3	-17.2	-19.1	-19.7	-15.5	-13.9
S22	dB	-15.9	-13.6	-13.2	-13.9	-15.4	-16	-17.7	-19.6	-16.3	-15
P1	dBm	16.7	17.1	17.7	17.4	16.8	16.1	16.2	16.4	14.5	13.6
OIP3	dBm	30.3	31.6	31.3	30.7	29.1	28.9	28.3	28.3	27.1	24.9
NF	dB	1.98	1.62	1.7	1.68	1.81	1.86	1.93	1.98	2.08	2.29

Typical Performance ( $V_c = 3.2V$ ,  $I_c = 75mA$ ,  $T = 25^\circ C$ )

Freq	MHz	30	50	70	900	1900	2140	2450	2650	3500	4500
S21	dB	29.9	29.2	28.9	25.9	21.9	21.2	20.3	19.7	18.1	16.9
S11	dB	-12.8	-14	-14.4	-15.8	-16	-17.1	-19.1	-19.6	-15.8	-14.2
S22	dB	-14.6	-12.7	-12.3	-13.5	-15.4	-16	-17.8	-19.8	-16.6	-15
P1	dBm	17.3	17.8	18.4	16.9	16.6	16	16.2	16.5	14.5	13.7
OIP3	dBm	29.6	30.5	30.3	29.5	28	27.6	26.7	26.6	26.3	24.3
NF	dB	2.04	1.65	1.73	1.72	1.83	1.9	1.96	2	2.1	2.33

Typical Performance ( $V_c = 3.3V$ ,  $I_c = 86mA$ ,  $T = 25^\circ C$ )

Freq	MHz	30	50	70	900	1900	2140	2450	2650	3500	4500
S21	dB	30	29.3	29	25.9	21.9	21.2	20.3	19.7	18.2	16.9
S11	dB	-12.6	-13.7	-14	-15.5	-16.1	-17	-19	-19.4	-15.9	-14.2
S22	dB	-13.8	-12.1	-11.7	-13.1	-15.5	-16.2	-18	-20.1	-16.9	-15.1
P1	dBm	17.9	18.2	18.6	16.6	16.5	15.8	16.2	16.4	14.5	13.6
OIP3	dBm	28.6	29.8	29.6	29	27.4	26.7	26	25.6	24.8	23
NF	dB	2.11	1.7	1.76	1.74	1.89	1.93	1.99	2	2.15	2.4

### V-I Characteristics

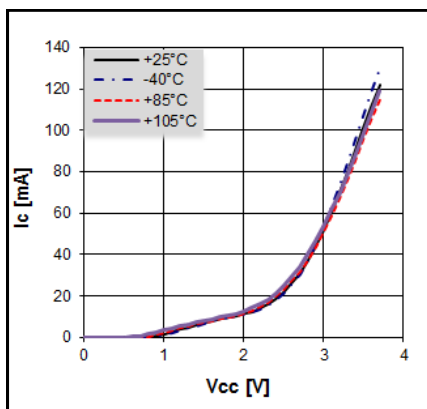

### BeRex SOT-363 Evaluation Board

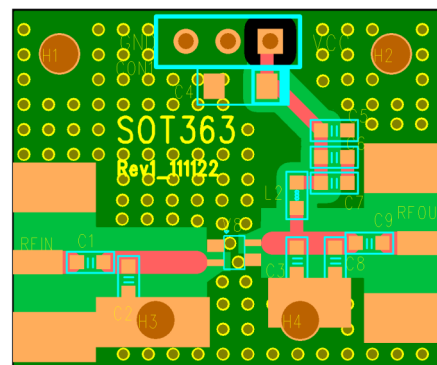

\*Dielectric constant \_ 4.2 \*31mil thick FR4 PCB

### Typical Device Data

S-parameters (Vc=3V, Ic=55mA, T=25°C, Bias Tee Data)

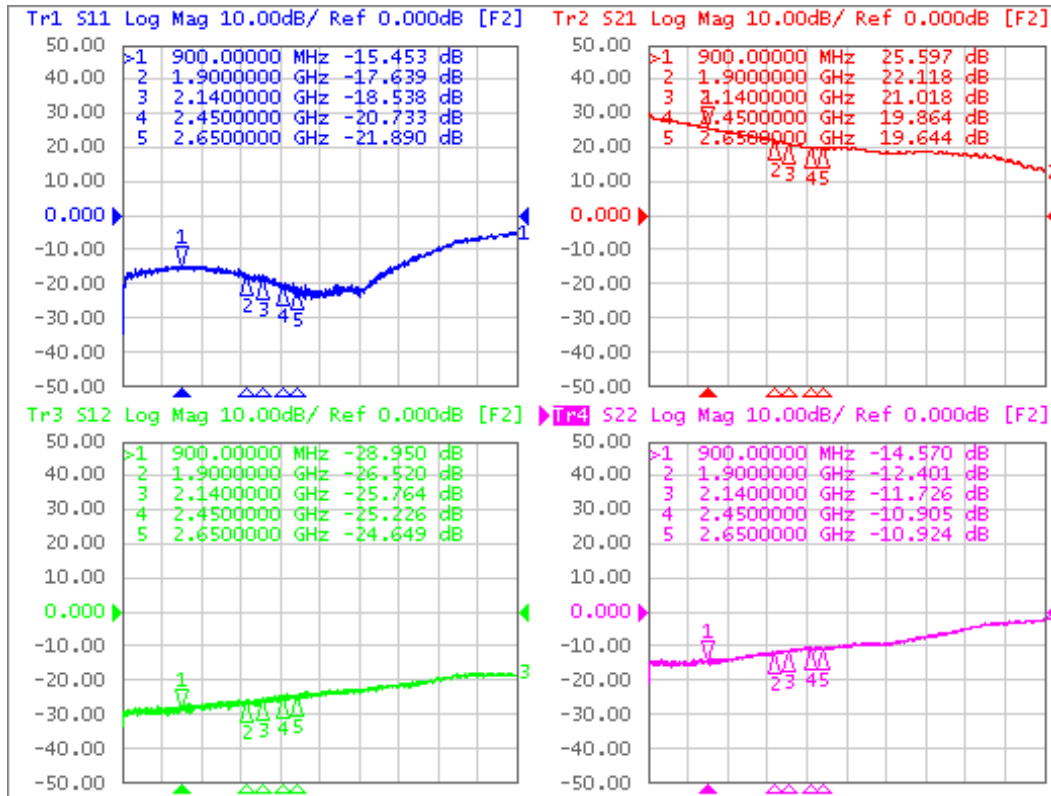

### S-Parameter

(Vdevice = 3.0V, Icc = 55mA, T = 25 °C, calibrated to device leads, Bias Tee Data)

Freq [MHz]	S11 Mag	S11 Ang	S21 Mag	S21 Ang	S12 Mag	S12 Ang	S22 Mag	S22 Ang
70.00	0.125	-168.1	26.57	169.6	0.033	11.51	0.172	-163.6
900.00	0.17	73.68	19.0	130.4	0.035	28.7	0.181	135.7
1000.00	0.17	68.3	18.4	126.8	0.38	227	0.19	135.5
1500.00	0.156	44.0	14.69	112.6	0.042	31.7	0.218	121.2
2000.00	0.125	35.0	12.1	97.7	0.047	40.2	0.248	109.8
2500.00	0.085	29.1	9.61	93.1	0.056	48.8	0.282	94.1
3500.00	0.075	76.9	8.51	74.8	0.065	56.2	0.328	63.8
4000.00	0.141	93.7	8.18	69.0	0.080	56.9	0.393	50.4

**Typical Performance**  
 (Vc=3V, Ic=55mA, T=25°C)

Pin-Pout-Gain

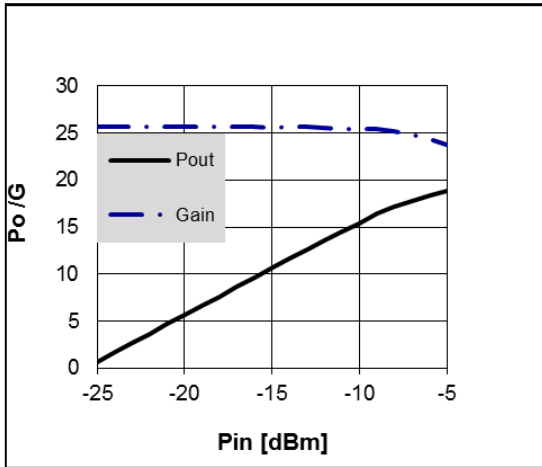
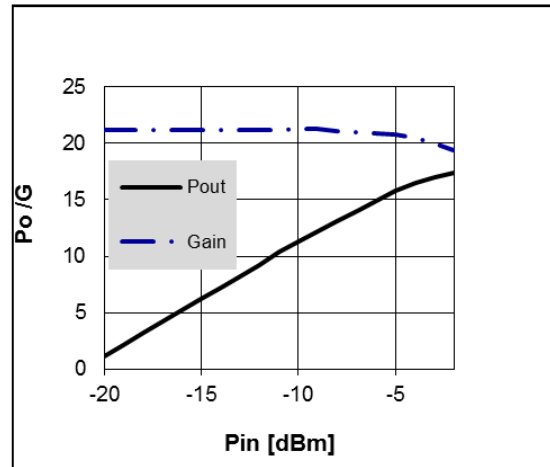
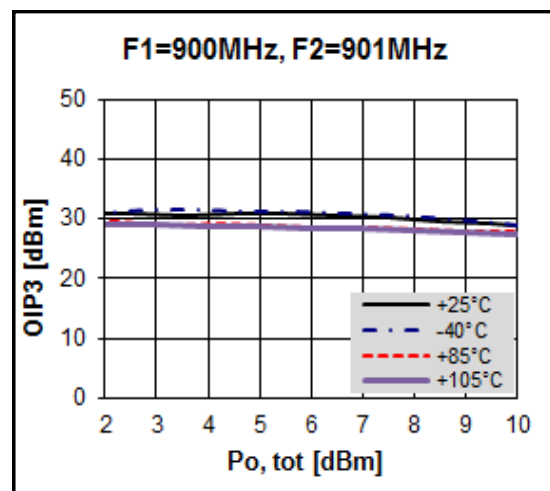
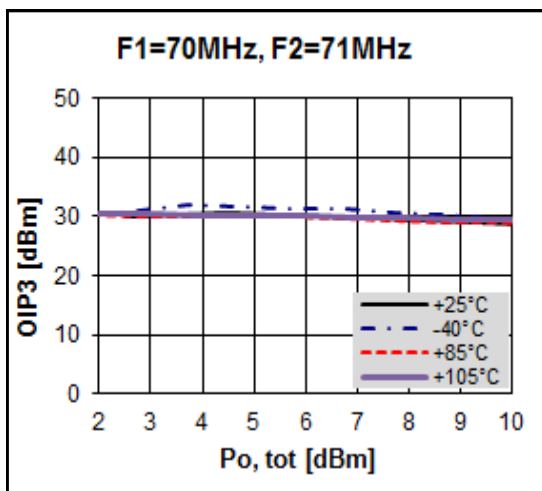
**900MHz**

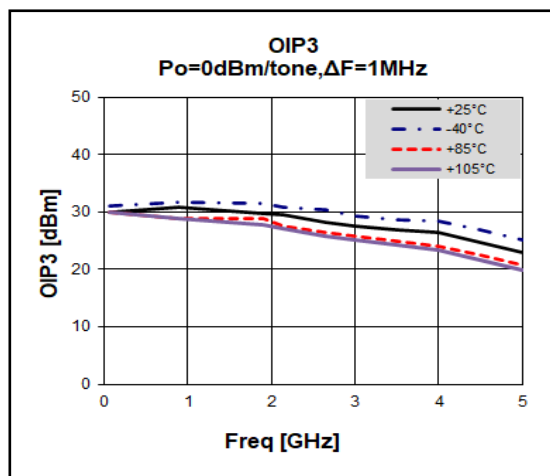
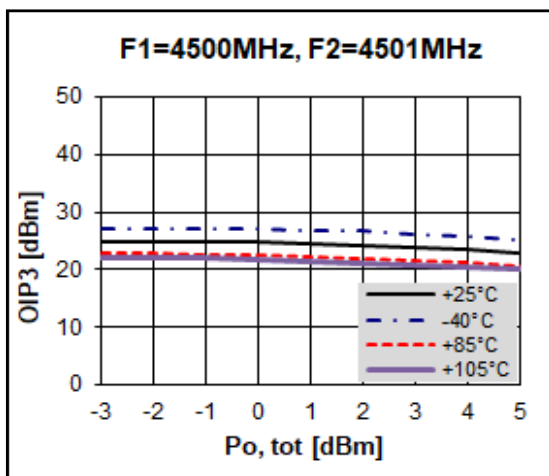
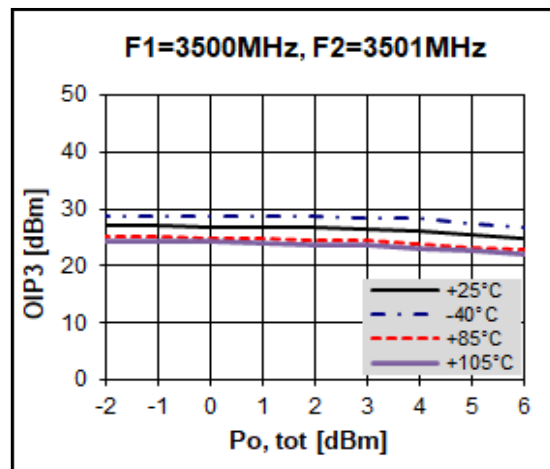
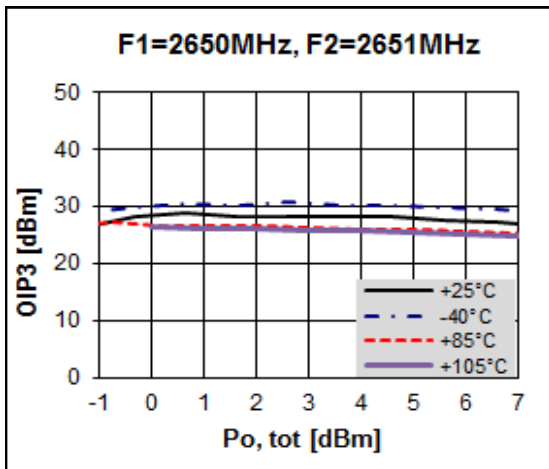
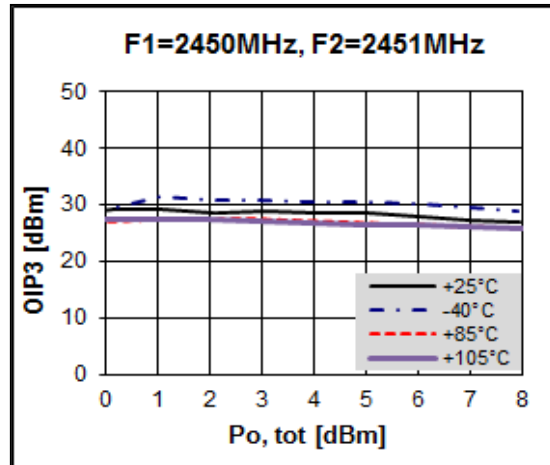
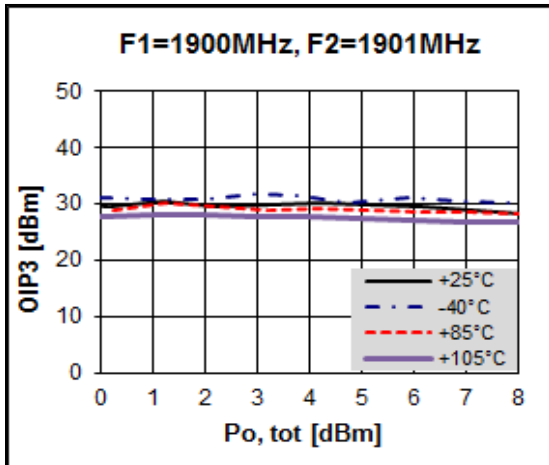
**1900 MHz**
**OIP3**

**OIP3**

### Gain Flatness

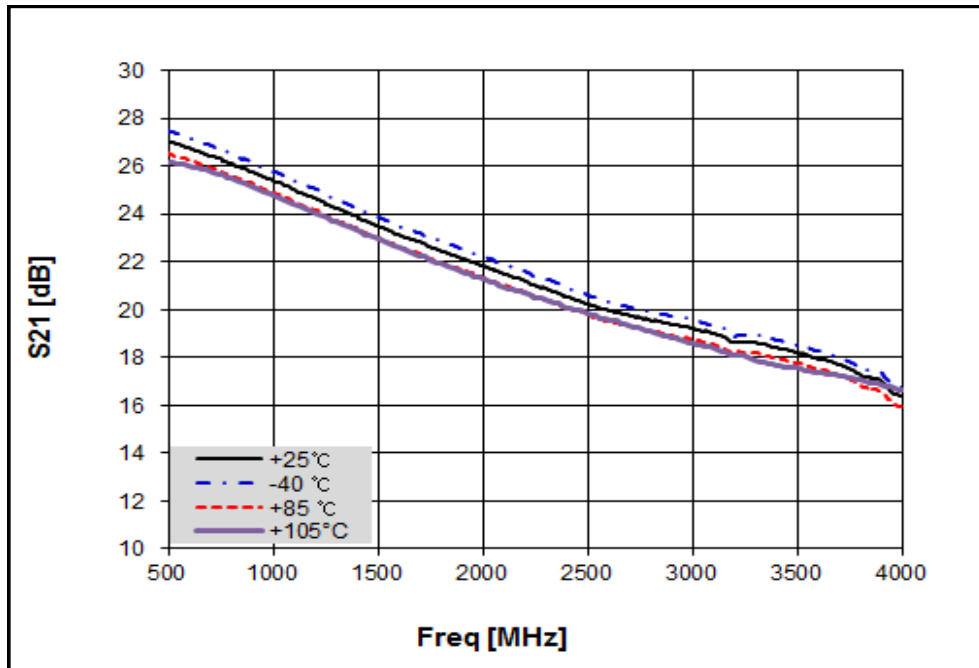
0.7 ~ 3GHz App



3 ~ 4GHz App

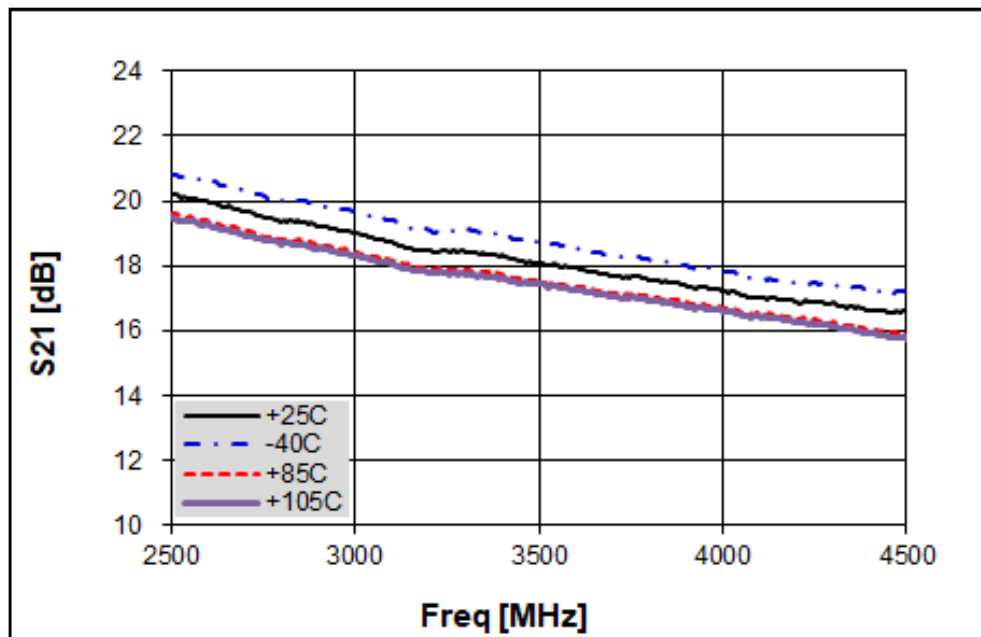

### Gain Flatness

4 ~ 5GHz App

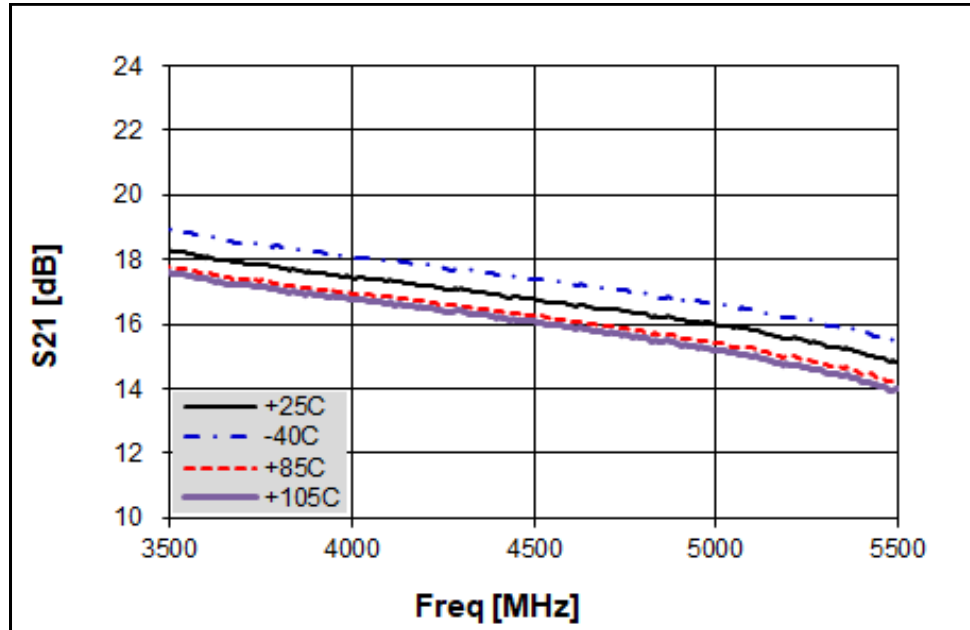

### SOT-363 Package Outline Dimension (Unit. mm )

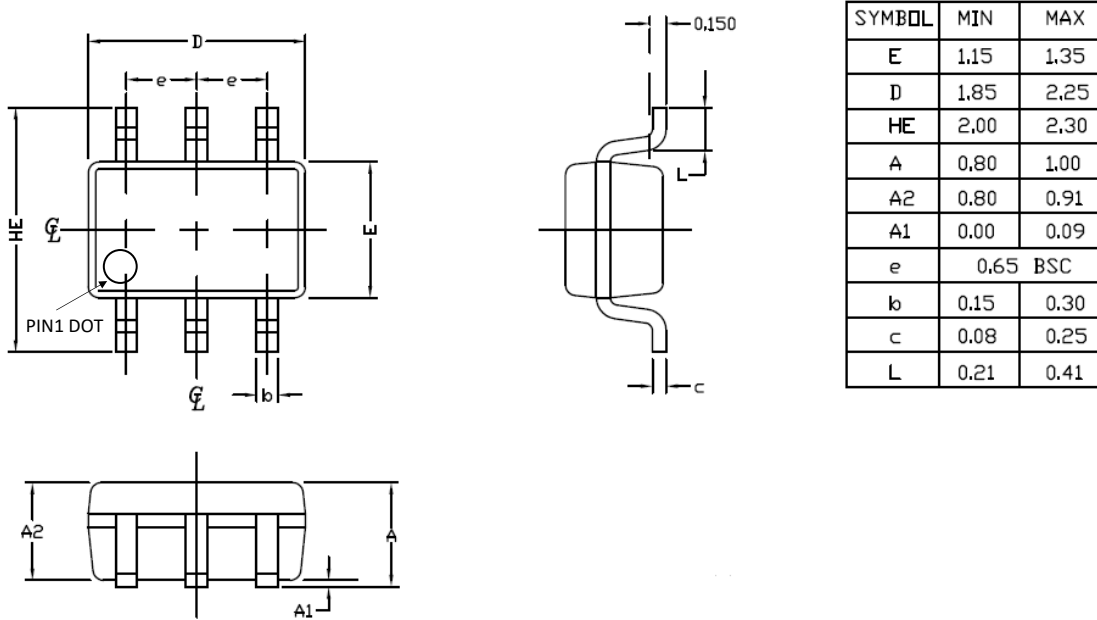

### Suggested PCB Land Pattern and PAD Layout

#### PCB Land Pattern

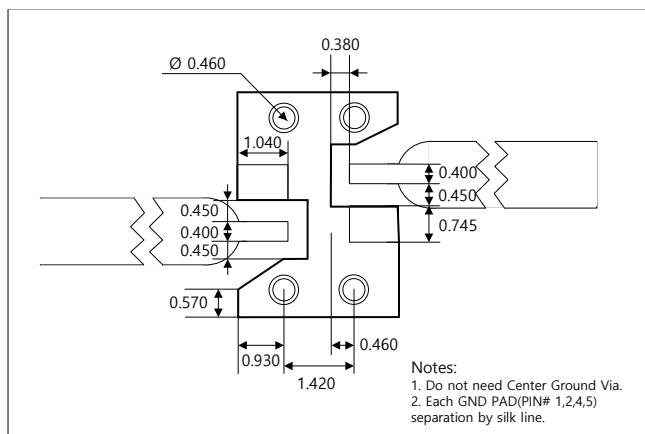

#### PCB Mounting

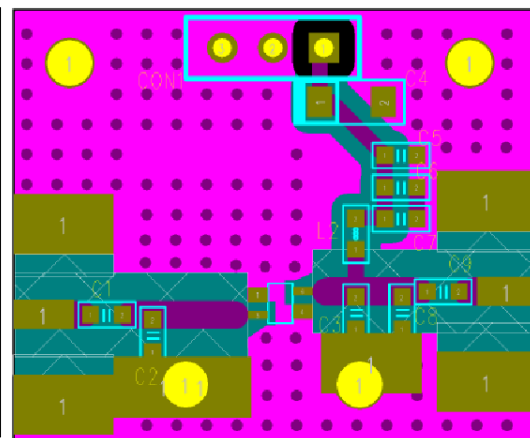

### Package Marking



X = Wafer No.

Pin 1

### New Package Marking

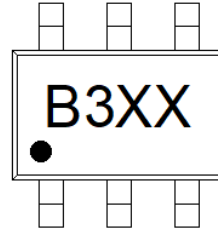

XX = Wafer No.

Pin 1

\* Note : New Package marking has been modified  
from BS3X to B3XX since June 2017.

### Tape & Reel

SOT-363

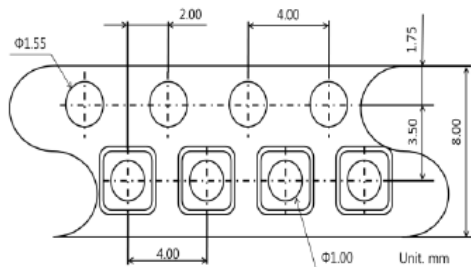

Packaging information:

Tape Width (mm): 8  
Reel Size (inches): 7  
Device Cavity Pitch (mm): 4  
Devices Per Reel: 3000

### Lead plating finish

100% Tin Matte finish

(All BeRex products undergoes a 1 hour, 150 degree C, Anneal bake to eliminate thin whisker growth concerns.)

## MSL / ESD Rating

<b>ESD Rating:</b>	Class 1B
<b>Value:</b>	<b>Passes &lt; 1000V</b>
<b>Test:</b>	Human Body Model (HBM)
<b>Standard:</b>	JEDEC Standard JS-001-2012
<b>MSL Rating:</b>	<b>Level 1 at +260°C convection reflow</b>
<b>Standard:</b>	JEDEC Standard J-STD-020



Proper ESD procedures should be followed when handling this device.

## RoHS Compliance

This part is compliant with Restrictions on the Use of Certain Hazardous Substances in Electrical and Electronic Equipment (RoHS) Directive 2011/65/EU as amended by Directive 2015/863/EU.



This product also is compliant with a concentration of the Substances of Very High Concern (SVHC) candidate list which are contained in a quantity of less than 0.1%(w/w) in each components of a product and/or its packaging placed on the European Community market by the BeRex and Suppliers.

## NATO CAGE code:

2	N	9	6	F
---	---	---	---	---

## Looking for pricing, stock, or lifecycle information?

Click below to explore more details on WIN SOURCE:

-  [View BGS3 on WIN SOURCE](#)
-  [BeRex Corporation Information](#)

## Optimize Your Supply Chain with WIN SOURCE Solutions

-  Global Sourcing Solution
-  Obsolete Management
-  Cost Control Management
-  Shortage Management
-  Alternative Solution
-  Excess Inventory Management