



MMIC SURFACE MOUNT

Wideband Amplifier

LVA-6183PN+

Mini-Circuits

50Ω 6 to 18 GHz Ultra-Low Phase Noise

THE BIG DEAL

- Wide Bandwidth, 6 to 18 GHz
- Ultra-Low Phase Noise, Typ. -165 dBc/Hz @ 10 kHz Offset
- Output P1dB, Typ. +19.6 dBm
- Output IP3, Typ. +28.7 dBm
- 4x4 mm 24-Lead QFN-Style Package

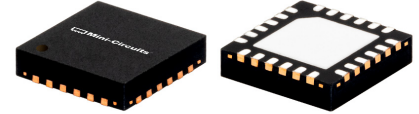

Generic photo used for illustration purposes only

APPLICATIONS

- Test and Measurement
- Radar, EW, and ECM Defense Systems
- 5G MIMO and Backhaul Radio Systems
- Signal Distribution Networks

FUNCTIONAL DIAGRAM

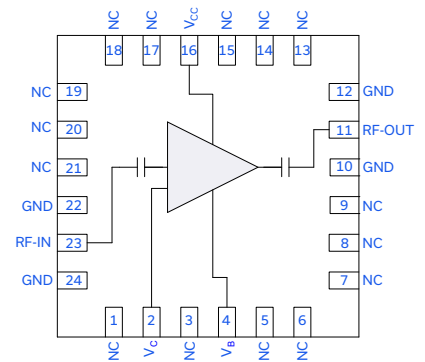

PRODUCT OVERVIEW

Mini-Circuits' LVA-6183PN+ is an ultra-low phase noise distributed MMIC amplifier fabricated on a GaAs HBT process. Operating from 6 to 18 GHz, this amplifier features high dynamic range and ultra-low phase noise along with 19.9 dB gain, +19.6 dBm P1dB, +28.7 dBm OIP3, and 4.1 dB noise figure. The LVA-6183PN+ is ideal for use with low noise signal sources and highly sensitive transceiver signal chains for commercial, industrial, and defense applications.

KEY FEATURES

Features	Advantages
Wide Bandwidth: 6 to 18 GHz	Supports a broad variety of applications including Test and Measurement Equipment, 5G Microwave Radio, Radar, and Electronic Warfare Systems.
Ultra-Low Phase Noise: -165 dBc/Hz @ 10 kHz Offset	Preserves signal quality by providing amplification with minimal degradation in system phase noise.
High Dynamic Range: • +19.6 dBm P1dB • 19.9 dB Gain	The MMIC amplifier's unique combination of ultra-low phase noise, high output IP3, high gain, and low noise figure enables optimum performance in sensitive high dynamic range receivers.
4x4 mm 24-Lead QFN-Style Package	Small footprint saves space in dense layouts while providing low inductance, repeatable transitions, and excellent thermal contact to the PCB. Industry standard packaging allows for ease of assembly in high volume manufacturing processes.

REV. A
ECO-025575
LVA-6183PN+
MCL NY
250530





MMIC SURFACE MOUNT

Wideband Amplifier

LVA-6183PN+

50Ω 6 to 18 GHz Ultra-Low Phase Noise

ELECTRICAL SPECIFICATIONS¹ AT +25°C, V_{CC} = +6 V, V_C = +6 V, V_B = +5.4 V, & Z_o = 50Ω UNLESS NOTED OTHERWISE

Parameter	Condition (GHz)	Min.	Typ.	Max.	Units
Frequency Range		6		18	GHz
Additive Phase Noise ²	6		-165		dBc/Hz
Gain	6	17.9	18.7		dB
	9	18.6	19.4		
	12	19.1	19.9		
	15	17.7	18.6		
	18	15.9	16.9		
Input Return Loss	6		12		dB
	9		13		
	12		17		
	15		11		
	18		20		
Output Return Loss	6		15		dB
	9		12		
	12		19		
	15		18		
	18		15		
Isolation	6-18		41.3		dB
Output Power at 1 dB Compression (P1dB)	6		+20.3		dBm
	9		+20.3		
	12		+19.6		
	15		+17.5		
	18		+14.6		
Output Power at 3 dB Compression (P3dB)	6		+23.0		dBm
	9		+22.3		
	12		+21.3		
	15		+20.1		
	18		+17.5		
Output Third-Order Intercept Point (P _{OUT} = 0 dBm/Tone)	6		+29.2		dBm
	9		+29.2		
	12		+28.7		
	15		+26.5		
	18		+23.3		
Input Third-Order Intercept Point (P _{OUT} = 0 dBm/Tone)	6		+10.5		dBm
	9		+9.8		
	12		+8.8		
	15		+7.8		
	18		+6.4		
Noise Figure	6		4.6		dB
	9		4.3		
	12		4.1		
	15		4.9		
	18		5.7		
Device Operating Voltage (V _{CC})			+6		V
Device Operating Current (I _{CC}) ³			123		mA
Collector Voltage (V _C)			+6		V
Collector Current (I _C)			7.5		mA
Base Voltage (V _B) ⁴			+5.4		V
Base Current (I _B)			12.4		mA
Device Current Variation Vs. Temperature ⁵			12.2		μA/°C
Device Current Variation Vs. Voltage ⁶			-0.0044		mA/mV

1. Tested in Mini-Circuits Characterization Test Board TB-LVA-6183PNC+. See Figure 2. De-embedded to the device reference plane.

2. P_{IN} = +3 dBm and Offset Frequency = 10 kHz

3. Current at P_{IN} = -25 dBm. Current increases to 180 mA at P3dB.

4. 50Ω series resistor may be used to create V_B = +5.4 V from available +6 V source.

5. (Current at +105°C - Current at -45°C)/(+150°C)

6. (Current at +6.25 V - Current at +5.75 V) / (+6.25 V - +5.75 V)





TYPICAL PERFORMANCE GRAPHS

Note: The following data was taken on the Mini-Circuits Characterization Test Board TB-LVA-6183PNC+ (Figure 2). All data taken at nominal conditions $V_{CC} = +6$ V, $V_C = +6$ V, and $V_B = +5.4$ V unless noted otherwise.

GAIN vs. TEMPERATURE
 $P_{IN} = -25$ dBm

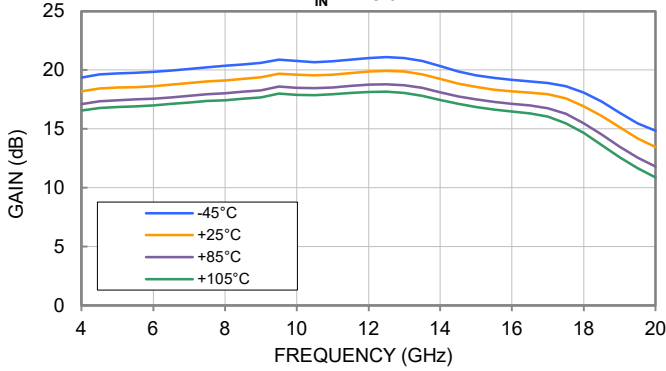

GAIN vs. BASE VOLTAGE (V_B)
 $P_{IN} = -25$ dBm, TEMPERATURE = +25°C

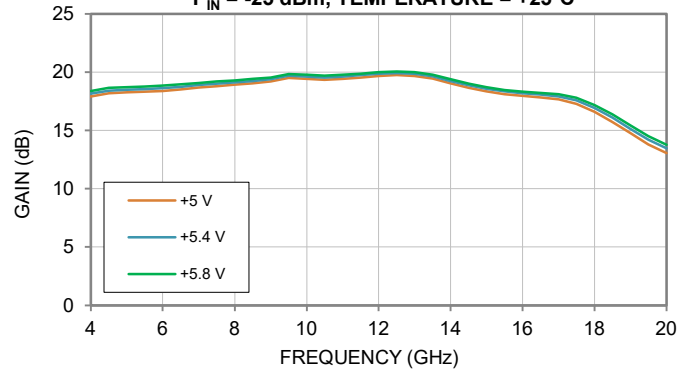

ISOLATION vs. TEMPERATURE
 $P_{IN} = -25$ dBm

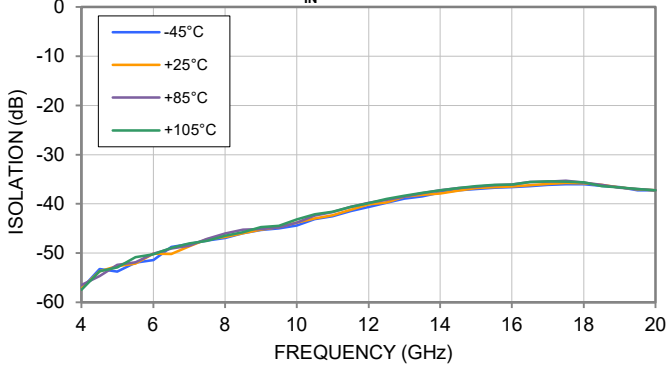

ISOLATION vs. BASE VOLTAGE (V_B)
 $P_{IN} = -25$ dBm, TEMPERATURE = +25°C

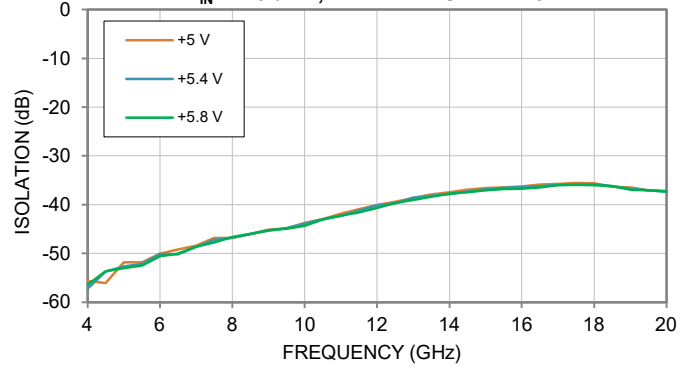

INPUT RETURN LOSS vs. TEMPERATURE
 $P_{IN} = -25$ dBm

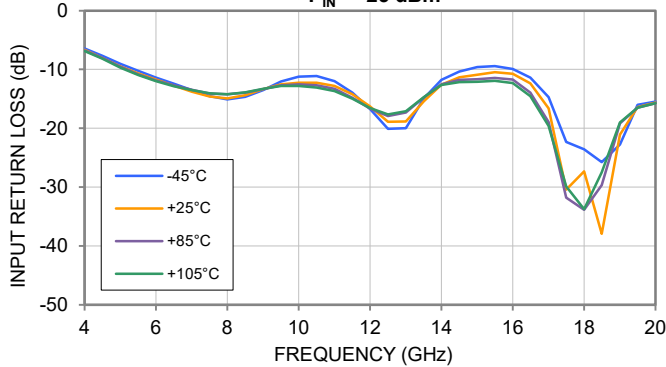

INPUT RETURN LOSS vs. BASE VOLTAGE (V_B)
 $P_{IN} = -25$ dBm, TEMPERATURE = +25°C

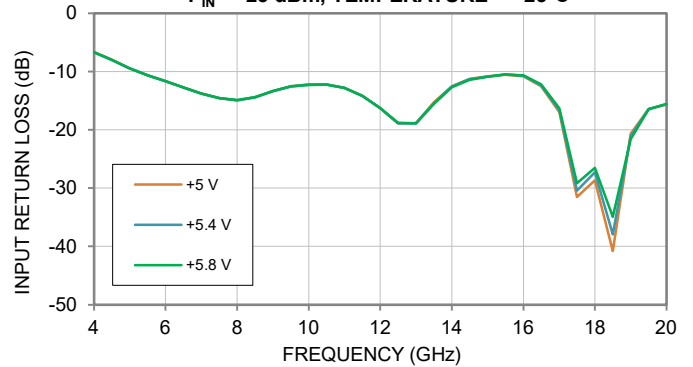



TYPICAL PERFORMANCE GRAPHS

Note: The following data was taken on the Mini-Circuits Characterization Test Board TB-LVA-6183PNC+ (Figure 2). All data taken at nominal conditions $V_{CC} = +6 V$, $V_C = +6 V$, and $V_B = +5.4 V$ unless noted otherwise.

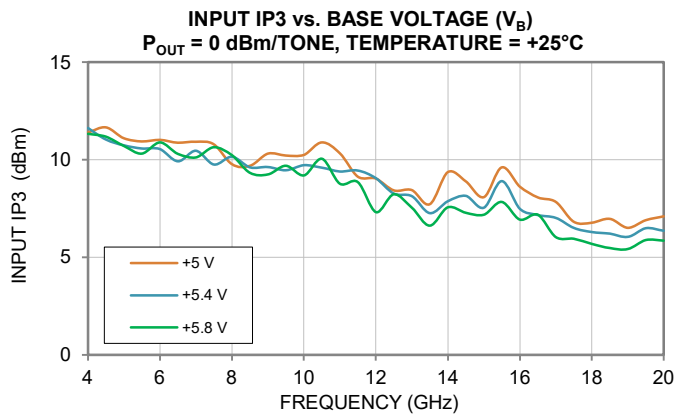
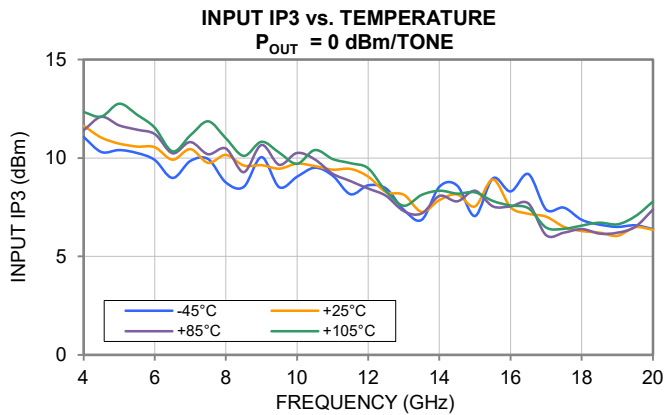
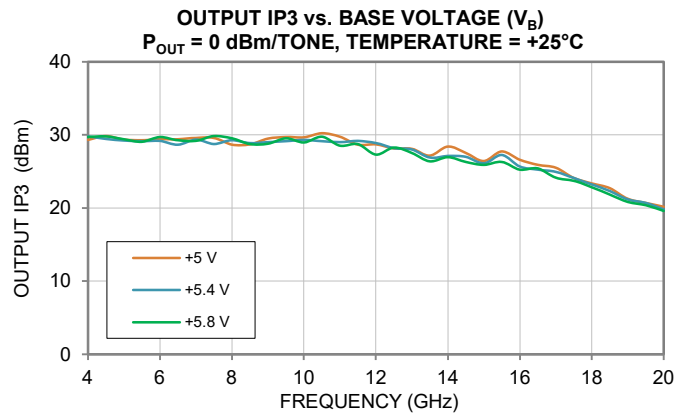
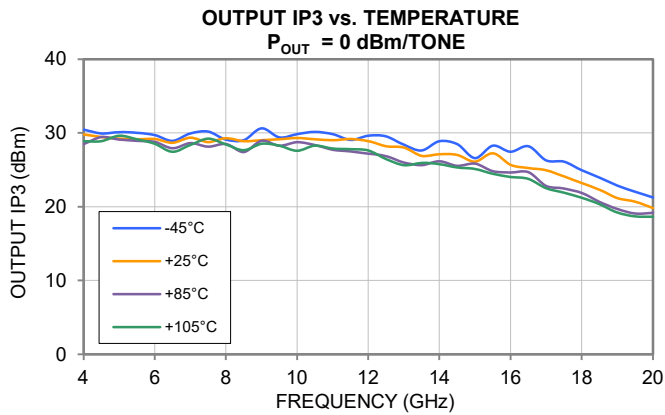
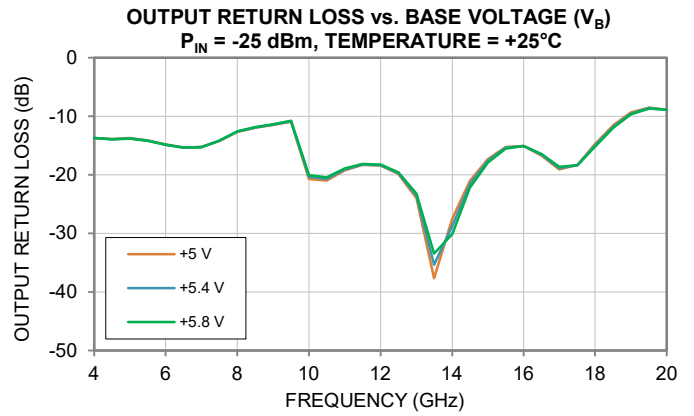
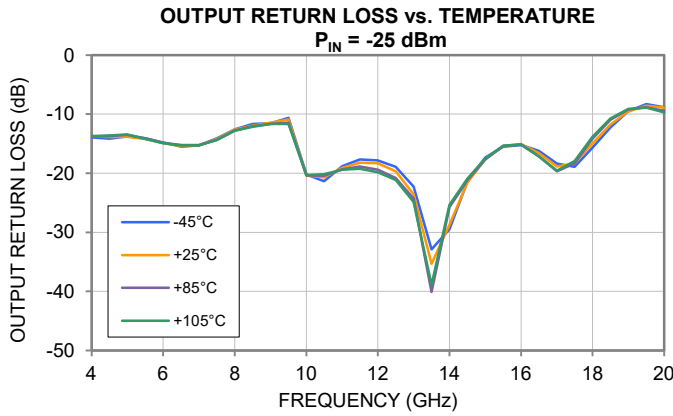



TYPICAL PERFORMANCE GRAPHS

Note: The following data was taken on the Mini-Circuits Characterization Test Board TB-LVA-6183PNC+ (Figure 2). All data taken at nominal conditions $V_{CC} = +6 V$, $V_C = +6 V$, and $V_B = +5.4 V$ unless noted otherwise.

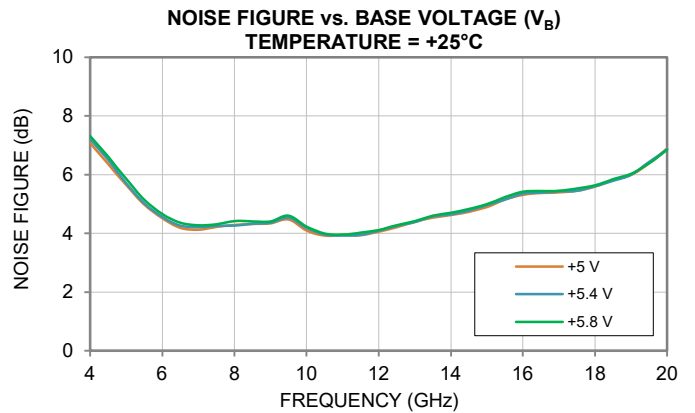
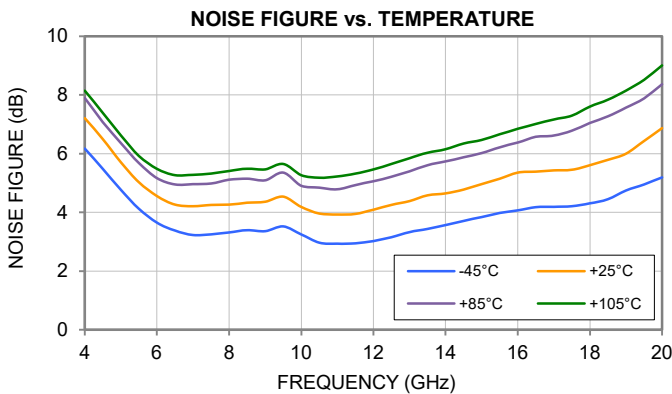
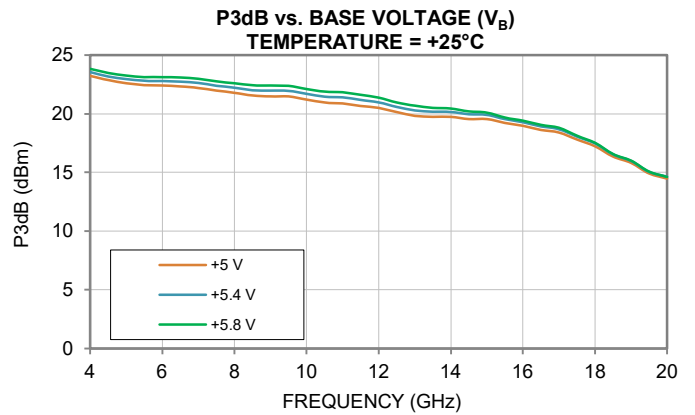
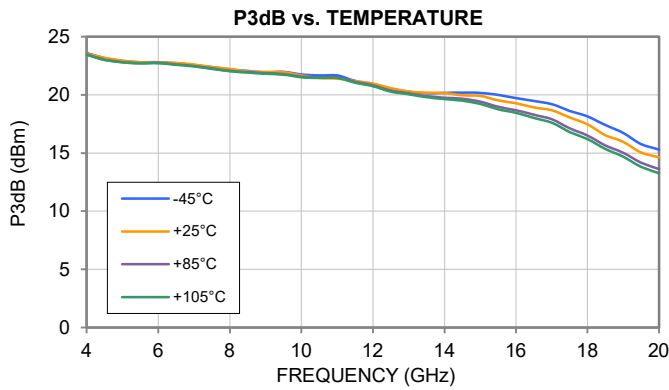
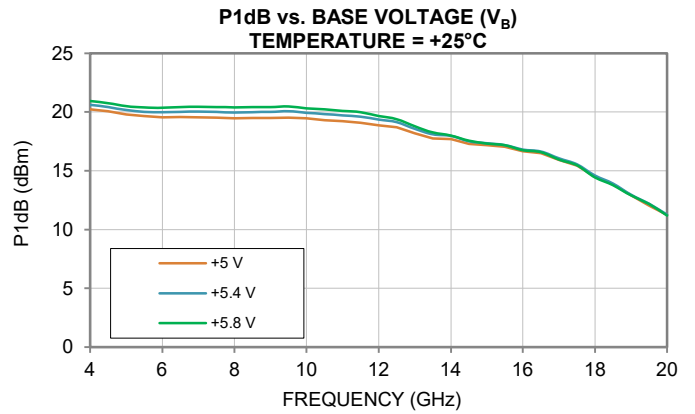
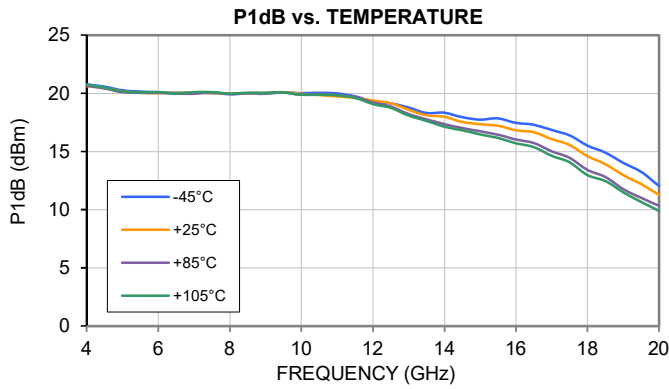



TYPICAL PERFORMANCE GRAPHS

Note: The following data was taken on the Mini-Circuits Characterization Test Board TB-LVA-6183PNC+ (Figure 2). All data taken at nominal conditions $V_{CC} = +6\text{ V}$, $V_C = +6\text{ V}$, and $V_B = +5.4\text{ V}$ unless noted otherwise.

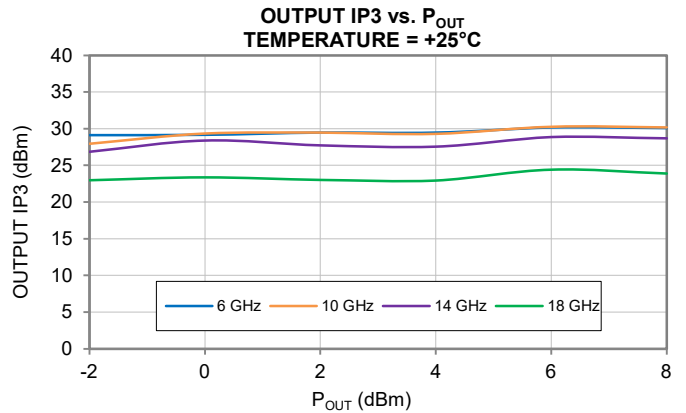
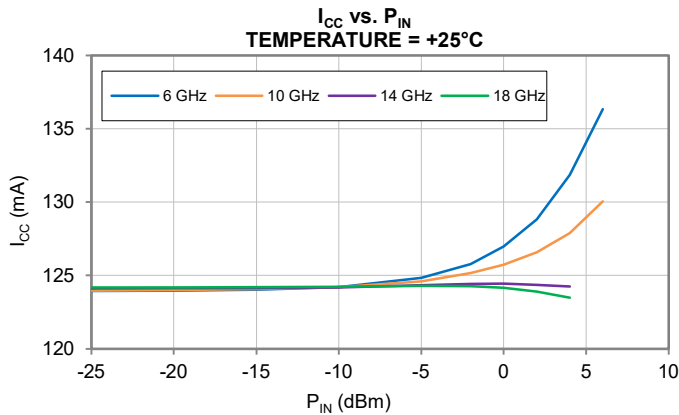
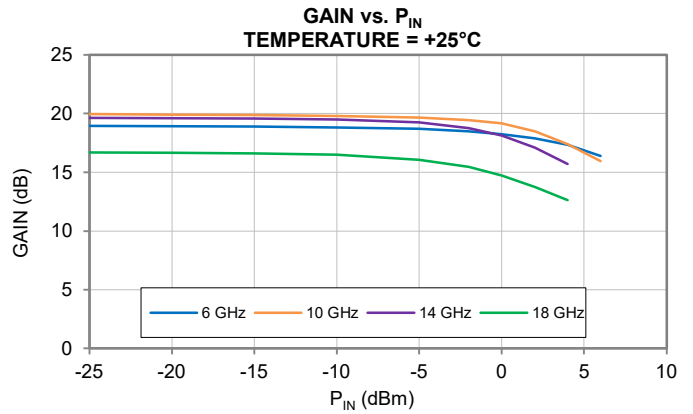
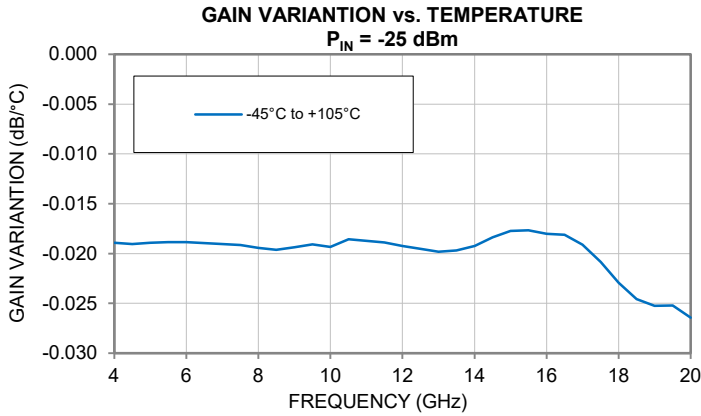



MMIC SURFACE MOUNT

Wideband Amplifier

LVA-6183PN+

Mini-Circuits

50Ω 6 to 18 GHz Ultra-Low Phase Noise

ADDITIVE PHASE NOISE VS. OFFSET FREQUENCY

(RF Frequency = 6 GHz, RF Input Power = +3 dBm)

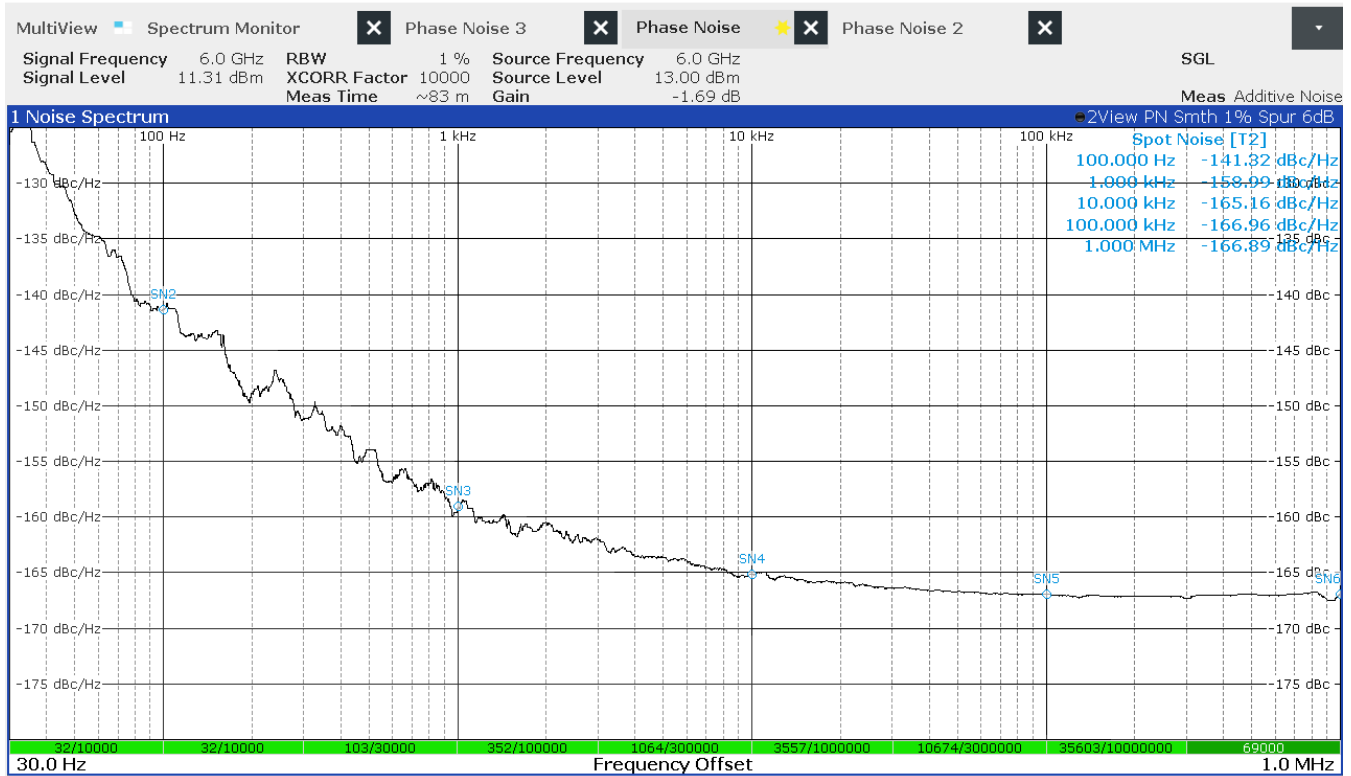



MMIC SURFACE MOUNT

Wideband Amplifier

LVA-6183PN+

50Ω 6 to 18 GHz Ultra-Low Phase Noise

ABSOLUTE MAXIMUM RATINGS⁷

Parameter	Ratings
Operating Temperature	-45°C to +105°C
Storage Temperature	-65°C to +150°C
Total Power Dissipation	1.27 W
Junction Temperature ⁸	+150°C
Input Power (CW), $V_{CC} = +6\text{ V}$, $V_C = +6\text{ V}$, $V_B = +5.4\text{ V}$	+25 dBm
DC Voltage on V_{CC}	+11 V
Current I_{CC}	170 mA
DC Voltage on V_C	+11 V
Current I_C	15 mA
DC Voltage on V_B	+11 V
Current I_B	30 mA

7. Permanent damage may occur if any of these limits are exceeded. Maximum ratings are not intended for continuous normal operation.

8. Peak temperature on top of Die.

THERMAL RESISTANCE

Parameter	Ratings
Thermal Resistance (Θ_{JC}) ⁹	35.3°C/W

9. Θ_{JC} = (Hot Spot Temperature on Die - Temperature at Ground Lead)/Dissipated Power

ESD RATING

	Class	Voltage Range	Reference Standard
HBM	1C	1000 V to < 2000 V	ANSI/ESDA/JEDEC JS-001-2017
CDM	C3	≥ 1000 V	JESD22-C101F



ESD HANDLING PRECAUTION: This device is designed to be Class 1C for HBM. Static charges may easily produce potentials higher than this with improper handling and can discharge into DUT and damage it. As a preventive measure, industry standard ESD handling precautions should be used at all times to protect the device from ESD damage.

MSL RATING

Moisture Sensitivity: MSL1 in accordance with IPC/JEDEC J-STD-020E/JEDEC J-STD-033C





FUNCTIONAL DIAGRAM

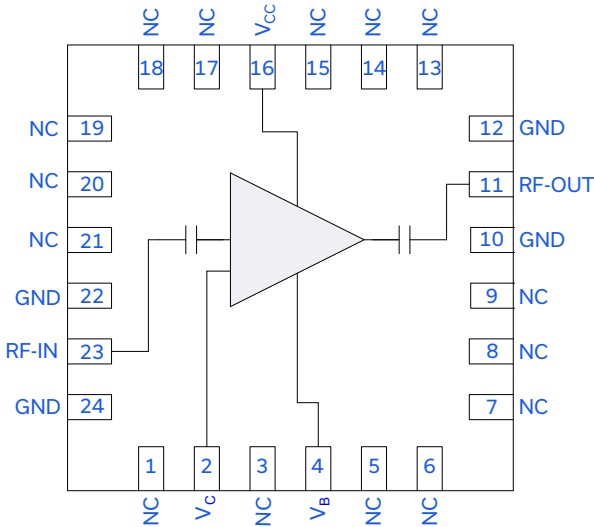

Figure 1. LVA-6183PN+ Functional Diagram

PAD DESCRIPTION

Function	Pad Number	Application Description (Refer to Figure 2)
RF-IN	23	RF-IN Pad connects to RF input port.
RF-OUT	11	RF-OUT Pad connects to RF output port.
V _{CC}	16	DC Input Pad connects to supply voltage input port.
V _C	2	DC Input Pad connects to collector voltage input port.
V _B	4	DC Input Pad connects to base voltage input port.
GND	10, 12, 22, 24	Connects to ground.
NC	1, 3, 5-9, 13-15, 17-21	Not used internally. Connects to ground on evaluation board.

EVALUATION BOARD

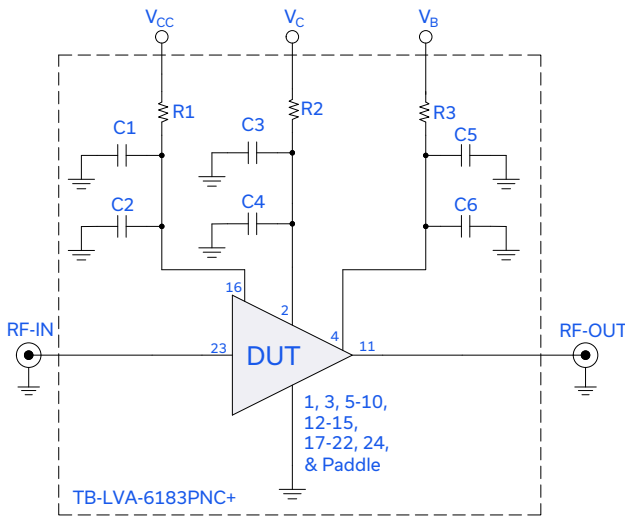

Figure 2. LVA-6183PN+ Characterization and Application Circuit

Electrical Parameters and Conditions

Gain, Return Loss, Output Power at 1dB Compression (P1dB), Output IP3 (OIP3), and Noise Figure measured using N5245A PNA-X Microwave Network Analyzer.

Conditions:

1. Gain and Return Loss: P_{IN} = -25 dBm
2. Output IP3 (OIP3): Two tones, spaced 1 MHz apart, 0 dBm/Tone at output.

Power ON/Power OFF Sequence

Caution: Permanent damage to the device will occur if the Power ON and Power OFF sequences are not followed.

Power ON:

- 1) Set V_{CC} = +6 V.
- 2) Set V_C = +6 V.
- 3) Set V_B = +5.4 V.
- 4) Turn on V_{CC}, V_C, and V_B.
- 5) Apply RF signal.

Power OFF:

- 1) Turn off RF signal.
- 2) Turn off V_{CC}, V_C, and V_B.

Component	Value	Size	Part Number	Manufacturer
C1, C3, C5	0.1 μF	0402	GRM155R71H104KE14J	Murata
C2, C4, C6	100 pF	0402	GRM1555C1H101JA01D	Murata
R1, R2, R3 ¹⁰	0Ω	0402	RK73Z1ETTP	KOA Speer

10. R3 can be swapped for a 50Ω resistor to create V_B = +5.4 V from available +6 V source.



MMIC SURFACE MOUNT

Wideband Amplifier

LVA-6183PN+

Mini-Circuits

50Ω 6 to 18 GHz Ultra-Low Phase Noise

CASE STYLE DRAWING

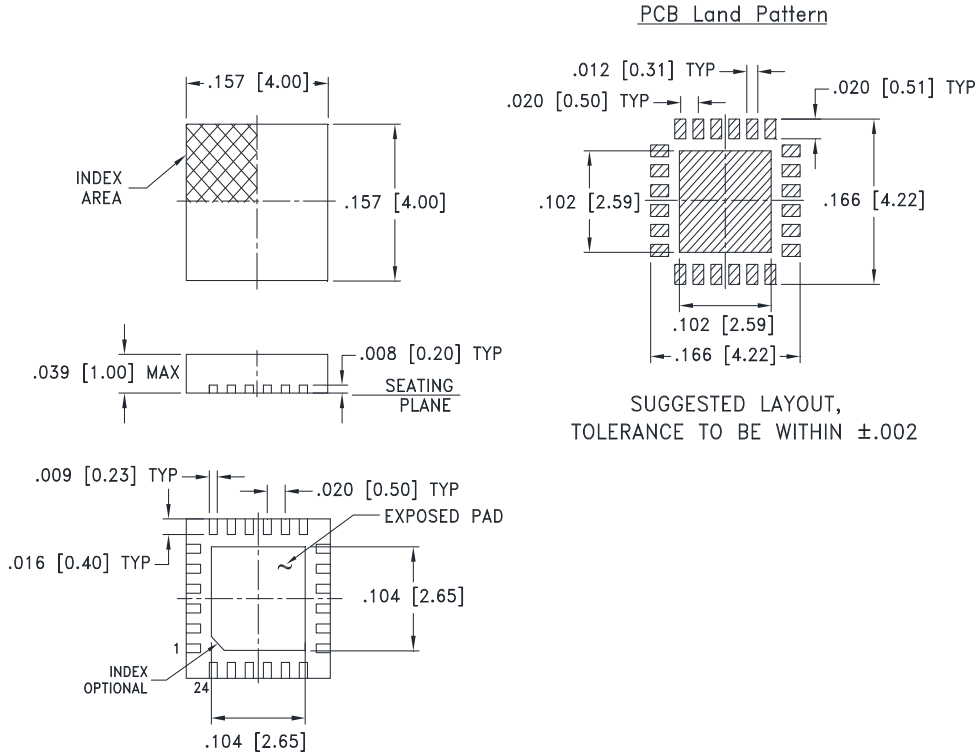

Weight: .04 Grams

Dimensions are in inches [mm]. Tolerances in inches: 2 Pl. ± .01; 3 Pl. ± .005 inches

PRODUCT MARKING

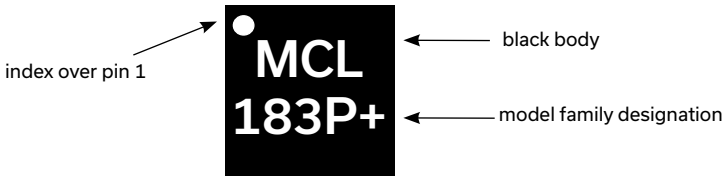

Marking may contain other features or characters for internal lot control



MMIC SURFACE MOUNT

Wideband Amplifier

LVA-6183PN+

50Ω 6 to 18 GHz Ultra-Low Phase Noise

ADDITIONAL DETAILED INFORMATION IS AVAILABLE ON OUR DASH BOARD

[CLICK HERE](#)

Performance Data & Graphs	Data Graphs S-Parameter (S2P Files) Data Set (.zip file)
Case Style	DG1847 Plastic package, exposed paddle, Lead Finish: Matte-Tin
RoHS Status	Compliant
Tape & Reel Standard quantities available on reel	F68 7" reels with 20, 50, 100, 200, 500, or 1000 devices
Suggested Layout for PCB Design	PL-777
Evaluation Board	TB-LVA-6183PNC+ Gerber File
Environmental Ratings	ENV08T1

NOTES

- A. Performance and quality attributes and conditions not expressly stated in this specification document are intended to be excluded and do not form a part of this specification document.
- B. Electrical specifications and performance data contained in this specification document are based on Mini-Circuit's applicable established test performance criteria and measurement instructions.
- C. The parts covered by this specification document are subject to Mini-Circuits standard limited warranty and terms and conditions (collectively, "Standard Terms"); Purchasers of this part are entitled to the rights and benefits contained therein. For a full statement of the standard terms and the exclusive rights and remedies thereunder, please visit Mini-Circuits' website at www.minicircuits.com/terms/viewterm.html



Looking for pricing, stock, or lifecycle information?

Click below to explore more details on WIN SOURCE:

 [View LVA-6183PN+ on WIN SOURCE](#)

 [Mini-Circuits Information](#)

Optimize Your Supply Chain with WIN SOURCE Solutions

-  Global Sourcing Solution
-  Obsolete Management
-  Cost Control Management
-  Shortage Management
-  Alternative Solution
-  Excess Inventory Management