



MMIC SURFACE MOUNT

Medium Power Amplifier

AVA-17303+

50Ω 17 to 31.5 GHz High Linearity Driver

THE BIG DEAL

- High P1dB, Typ. +22.9 dBm
- High OIP3, Typ. +33 dBm
- Supply Voltage, +6 V at 160 mA
- 4x4 mm 20-Lead QFN-Style Package

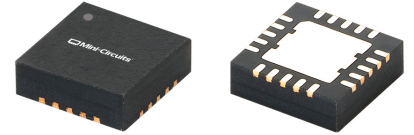

Generic photo used for illustration purposes only

APPLICATIONS

- Test and Measurement Equipment
- Satellite Communications
- Radar, EW, and ECM Defense Systems
- 5G mmWave, MIMO Wireless Infrastructure Systems
- Microwave Radio & VSAT

FUNCTIONAL DIAGRAM (Top View)

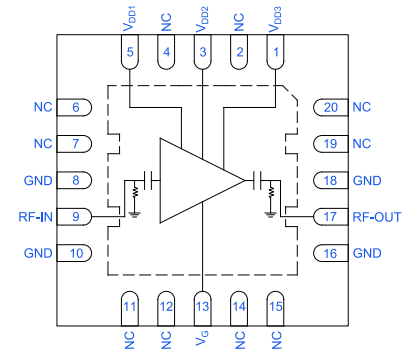

PRODUCT OVERVIEW

The AVA-17303+ is a GaAs MMIC Medium Power Amplifier operating from 17 to 31.5 GHz. This amplifier provides typical 20.5 dB of gain, +22.9 dBm P1dB, and +33 dBm OIP3 while operating from a +6 V power supply at 160 mA. Additionally, it is internally matched to 50Ω and comes in a 4x4 mm 20-Lead QFN-Style package. These characteristics make it ideally suited as a driver amplifier in point-to-point radios and communications systems requiring high operating output power while maintaining low distortion characteristics.

KEY FEATURES

Features	Advantages
High Gain, Typ. 20.5 dB High P1dB, Typ. +22.9 dBm	High gain and output power make this device excellent for wideband systems from 17 to 31.5 GHz that require at least 0.2 W of operating output power over the full band.
High OIP3, Typ. +33 dBm	High operating OIP3 provides very low in-band distortion products, enabling minimal signal degradation in high fidelity measurement systems and demanding communication systems.
4x4 mm 20-Lead QFN-Style Package	Small footprint saves space in dense layouts while providing low inductance, repeatable transitions, and excellent thermal contact to the PCB. Industry standard packaging allows for ease of assembly in high volume manufacturing processes.



MMIC SURFACE MOUNT

Medium Power Amplifier

AVA-17303+

50Ω 17 to 31.5 GHz High Linearity Driver

ELECTRICAL SPECIFICATIONS¹ AT +25°C, V_{DD} = +6 V, AND Z_o = 50Ω UNLESS NOTED OTHERWISE

Parameter	Condition (GHz)	Min.	Typ.	Max.	Units
Frequency Range		17		31.5	GHz
Gain	17	18.4	21.0		dB
	20	17.7	20.4		
	24	16.8	20.5		
	27	18.7	21.9		
	30	16.0	23.7		
	31.5	13.7	20.1		
Input Return Loss	17		11		dB
	20		17		
	24		12		
	27		8		
	30		10		
	31.5		7		
Output Return Loss	17		19		dB
	20		13		
	24		12		
	27		10		
	30		17		
	31.5		20		
Isolation	17 - 31.5		56		dB
Output Power at 1 dB Compression (P _{1dB})	17		+23.3		dBm
	20		+22.6		
	24		+22.9		
	27		+23.7		
	30		+23.2		
	31.5		+21.8		
Output Power at Saturation (P _{SAT}) ²	17		+25.2		dBm
	20		+23.7		
	24		+23.6		
	27		+23.8		
	30		+23.5		
	31.5		+21.9		
Output Third-Order Intercept (OIP3) (P _{OUT} = +6 dBm/Tone)	17		+31		dBm
	20		+31		
	24		+33		
	27		+33		
	30		+34		
	31.5		+31		
Noise Figure	17		5.7		dB
	20		4.9		
	24		4.1		
	27		3.7		
	30		3.4		
	31.5		3.5		
Device Operating Voltage (V _{DD}) ³		+5	+6	+7	V
Device Operating Current (I _{DD}) ⁴			160		mA
Gate Voltage (V _G)			-0.54		V
Gate Current (I _G) ⁵			57		μA
Device Current Variation vs. Temperature ⁶			-3.6		μA/°C

1. Tested on Mini-Circuits Evaluation Test Board TB-AVA-17303C+. See Figure 2. Board loss de-embedded.

2. Defined as output power at which change is 0.1 per 1 dB change in input power.

3. V_{DD} = V_{DD1} = V_{DD2} = V_{DD3}

4. Current at P_{IN} = -25 dBm. Increases to 250 mA at P1dB. I_{DD} = I_{DD1} + I_{DD2} + I_{DD3}.

5. Current at P_{IN} = -25 dBm. Increases to 300 μA at P1dB.

6. (Current at +85°C - Current at -55°C)/(140°C). V_G held constant over temperature.





MMIC SURFACE MOUNT

Medium Power Amplifier **AVA-17303+**

Mini-Circuits

50Ω 17 to 31.5 GHz High Linearity Driver

TYPICAL PERFORMANCE GRAPHS

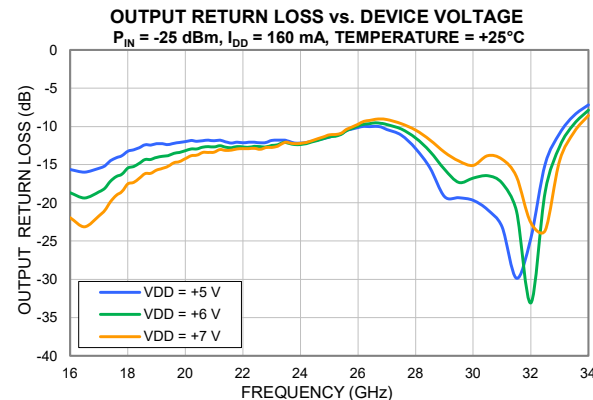
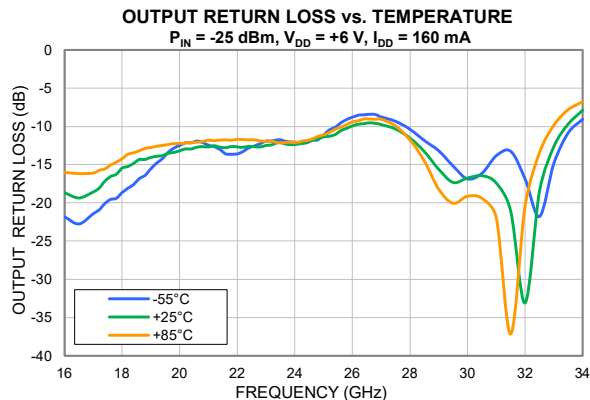
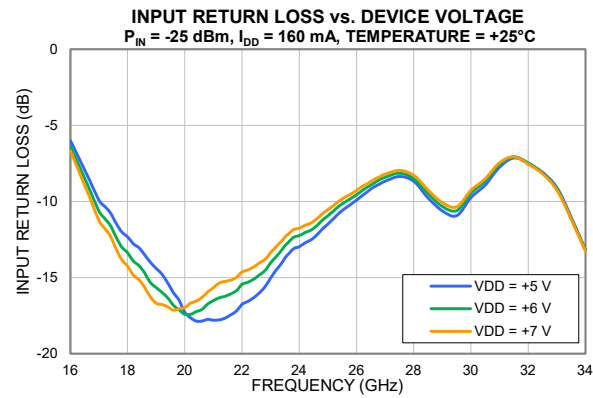
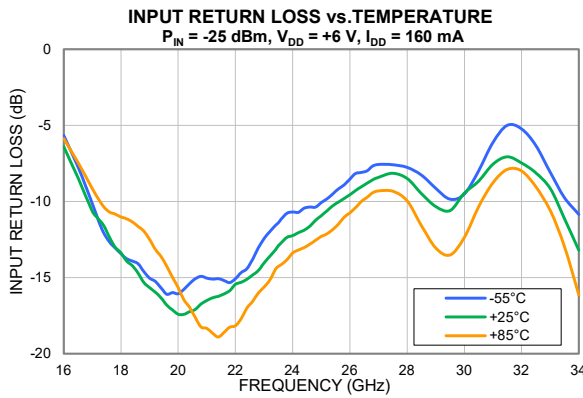
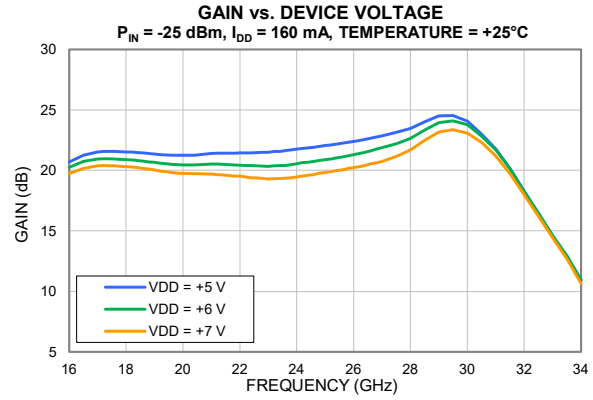
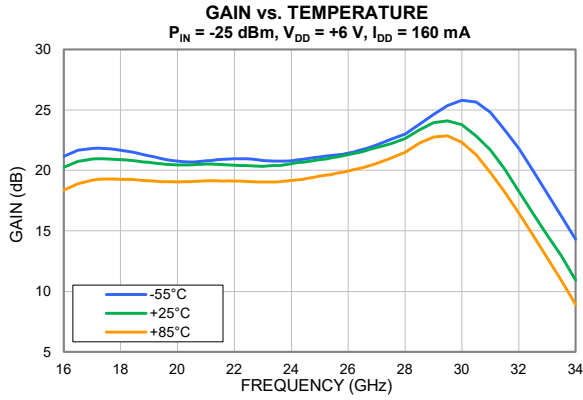



TYPICAL PERFORMANCE GRAPHS

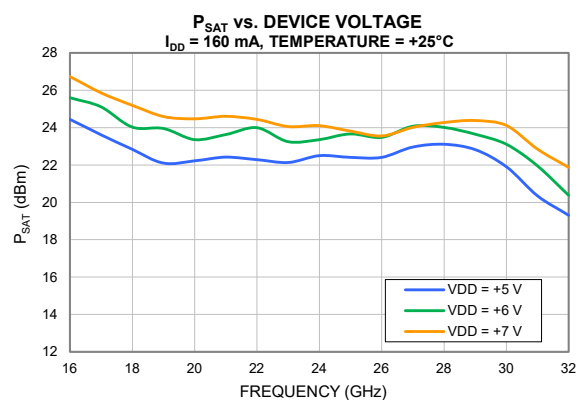
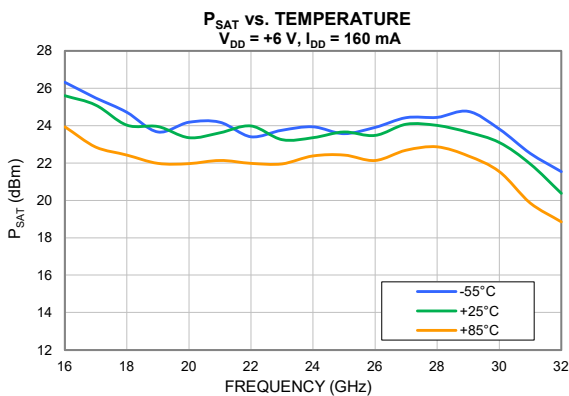
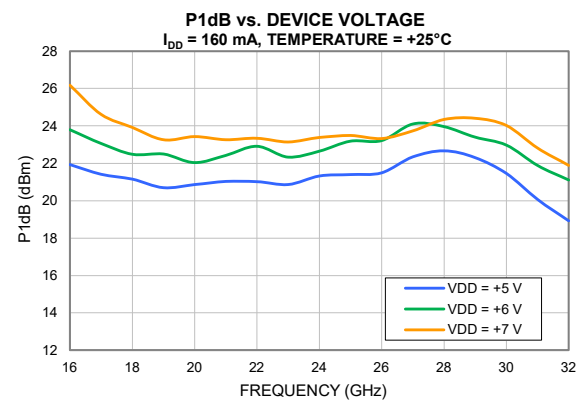
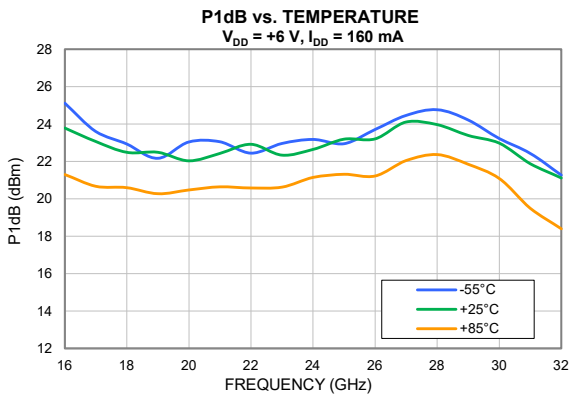
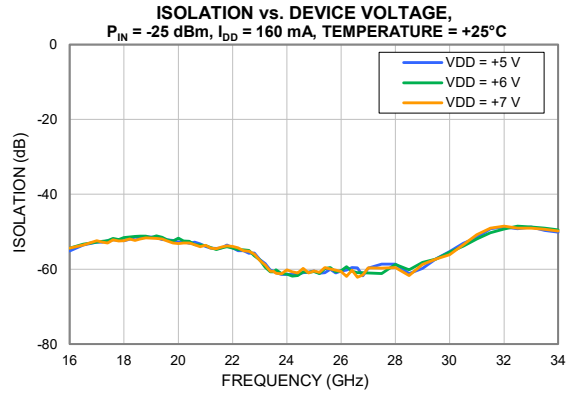
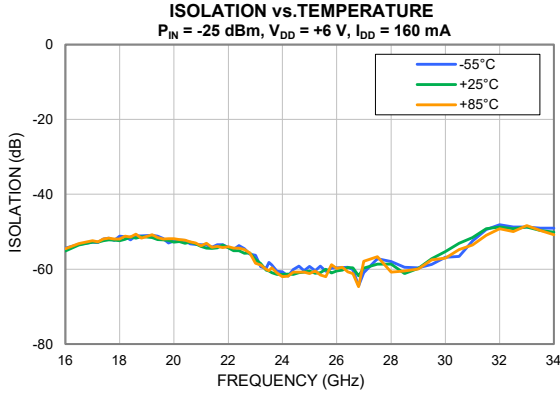



TYPICAL PERFORMANCE GRAPHS

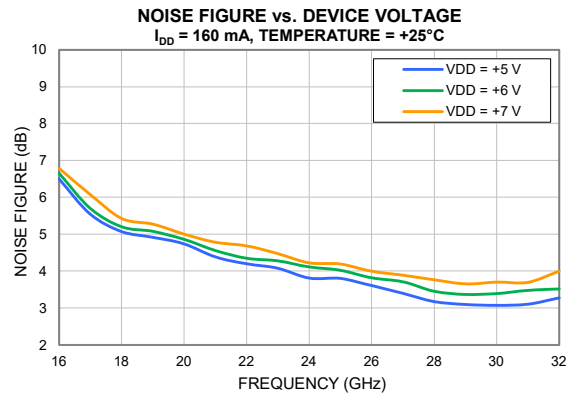
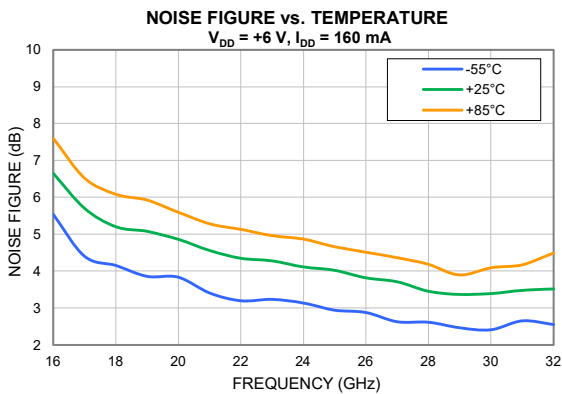
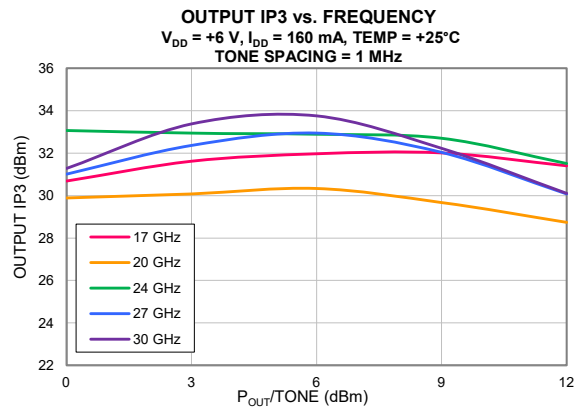
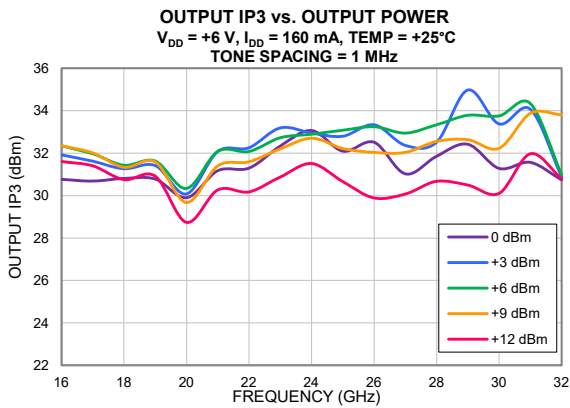
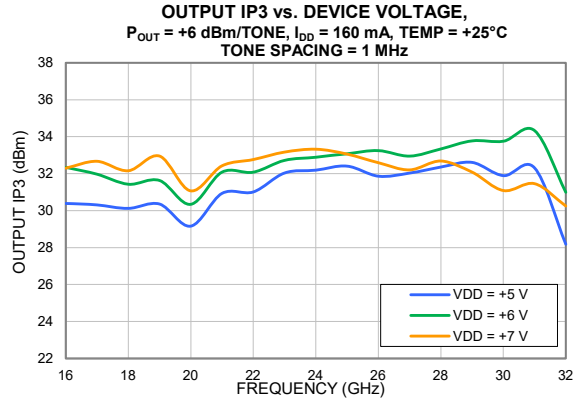
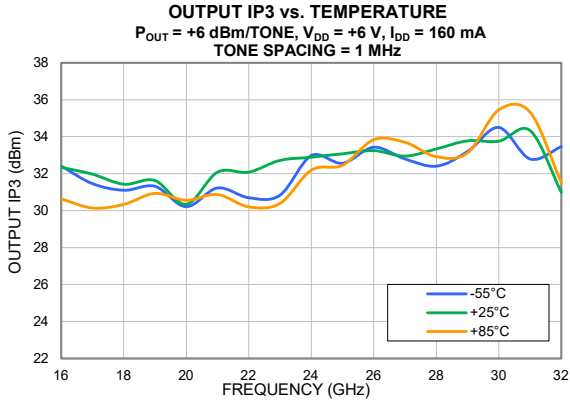



TYPICAL PERFORMANCE GRAPHS

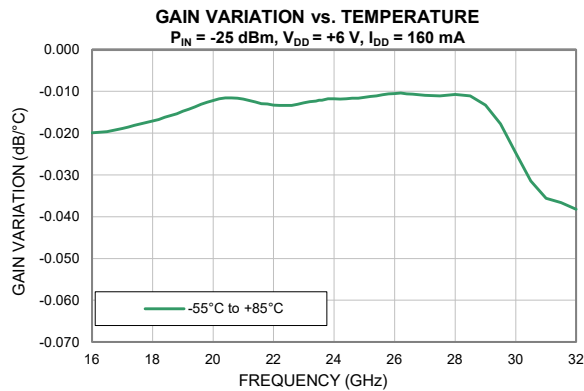
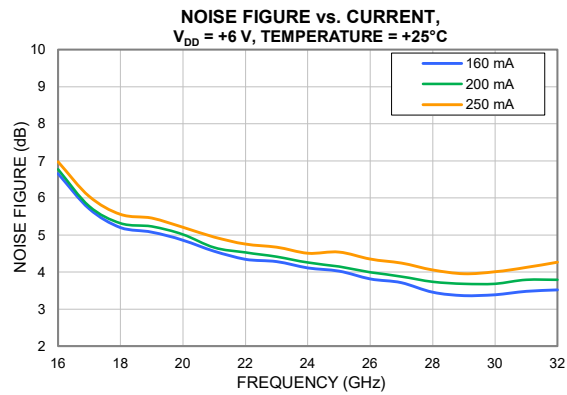
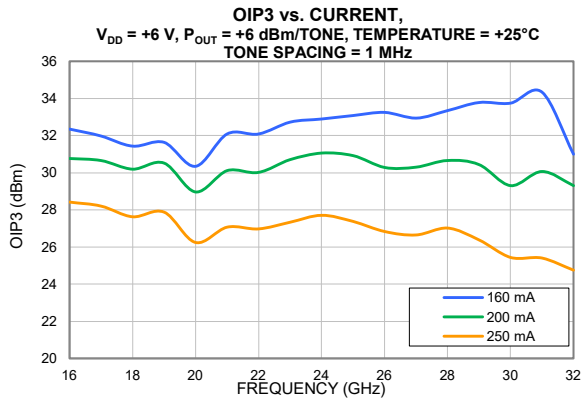
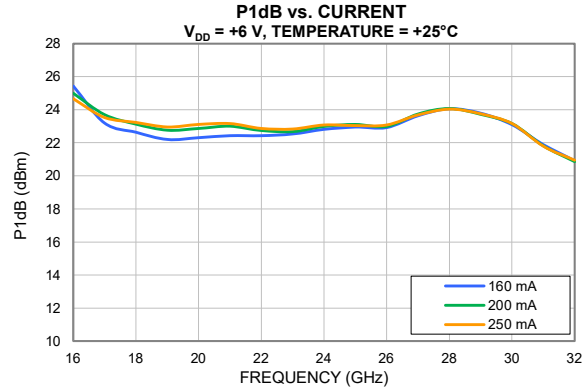
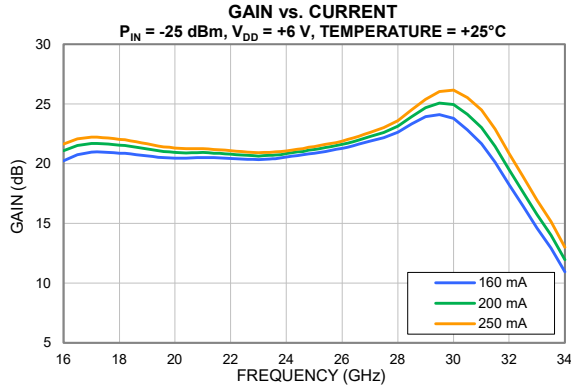



MMIC SURFACE MOUNT

Medium Power Amplifier

AVA-17303+

50Ω 17 to 31.5 GHz High Linearity Driver

ABSOLUTE MAXIMUM RATINGS⁷

Parameter	Ratings
Operating Temperature (ground lead)	-55°C to +85°C
Storage Temperature	-65°C to +150°C
Junction Temperature ⁸	+175°C
Total Power Dissipation	1.8 W
Input Power (CW), $V_{DD} = +6$ V	+25 dBm
DC Drain Voltage on V_{DD} ⁹	+9 V
DC Drain Current I_{DD} ¹⁰	500 mA
DC Voltage at RF-IN	+9 V
DC Voltage at RF-OUT	+9 V
DC Gate Voltage on V_G	-6 V to +1 V
DC Gate Current I_G	8 mA

7. Permanent damage may occur if any of these limits are exceeded. Maximum ratings are not intended for continuous normal operation.

8. Peak Temperature on top of Die.

9. $V_{DD} = V_{DD1} = V_{DD2} = V_{DD3}$.

10. $I_{DD} = I_{DD1} + I_{DD2} + I_{DD3}$.

THERMAL RESISTANCE

Parameter	Ratings
Thermal Resistance (Θ_{JC}) ¹¹	46.9°C/W

11. $\Theta_{JC} = (\text{Hot Spot Temperature on Die} - \text{Temperature at Ground Lead}) / \text{Dissipated Power}$

ESD RATING

	Class	Voltage Range	Reference Standard
HBM	1A	250 V to < 500 V	ANSI/ESDA/JEDEC JS-001-2023
CDM	C2A	500 V to < 750 V	ANSI/ESDA/JEDEC JS-002-2022



ESD HANDLING PRECAUTION: This device is designed to be Class 1A for HBM. Static charges may easily produce potentials higher than this with improper handling and can discharge into DUT and damage it. As a preventive measure Industry standard ESD handling precautions should be used at all times to protect the device from ESD damage.

MSL RATING

Moisture Sensitivity: MSL3 in accordance with IPC/JEDEC J-STD-020E/JEDEC J-STD-033C





FUNCTIONAL DIAGRAM (Top View)

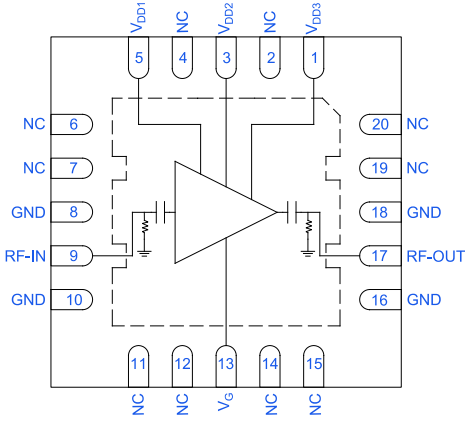

Figure 1. AVA-17303+ Functional Diagram

PAD DESCRIPTION

Function	Pad Number	Description (Refer to Fig 2)
RF-IN	9	RF-IN Pad connects to RF Input port.
RF-OUT	17	RF-OUT Pad connects to RF Output port.
V _{DD1}	5	DC input pad connects to Drain voltage 1.
V _{DD2}	3	DC input pad connects to Drain voltage 2.
V _{DD3}	1	DC input pad connects to Drain voltage 3.
V _G	13	DC input pad connects to Gate control voltage.
NC	2, 4, 6, 7, 11, 12, 14, 15, 19, 20	Not used internally. Connected to ground on test board.
GND	8, 10, 16, 18, Paddle	Connects to ground.

EVALUATION TEST BOARD

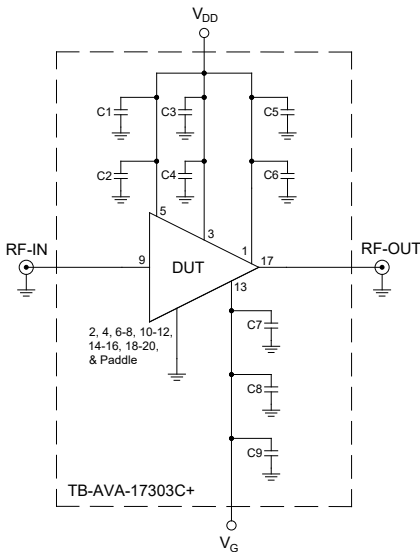

Figure 2. AVA-17303+ Evaluation and Application Circuit

Electrical Parameters and Conditions

Gain, Return Loss, Output Power at 1 dB Compression (P_{1dB}), Output IP3 (OIP3), and Noise Figure measured using N5245B PNA-X Microwave Network Analyzer.

Conditions:

- Gain and Return Loss: P_{IN} = -25 dBm
- Output IP3 (OIP3): Two tones, spaced 1 MHz apart, +6 dBm/Tone at output.

Power ON/Power OFF Sequence

Caution: Permanent damage to the device will occur if the Power ON and Power OFF sequences are not followed.

POWER ON:

- Set V_G = -1.2 V and Turn ON.
- Set V_{DD} = +6 V and Turn ON.
- Increase V_G to desired nominal I_{DD} = 160 mA.
- Turn ON RF signal.

POWER OFF:

- Turn OFF RF signal.
- Decrease V_G to -1.2 V.
- Turn OFF V_{DD}.
- Turn OFF V_G.

Component	Value	Size	Part Number	Manufacturer
C1, C3, C5, C9	10 μF	1206	CL31B106KBHNNNE	SAMSUNG
C2, C4, C6, C8	0.1 μF	0603	06035C104KAT2A	AVX CORPORATION
C7	100 pF	0603	GRM1885C1H101GA01D	MURATA



MMIC SURFACE MOUNT

Medium Power Amplifier

AVA-17303+

Mini-Circuits

50Ω 17 to 31.5 GHz High Linearity Driver

CASE STYLE DRAWING

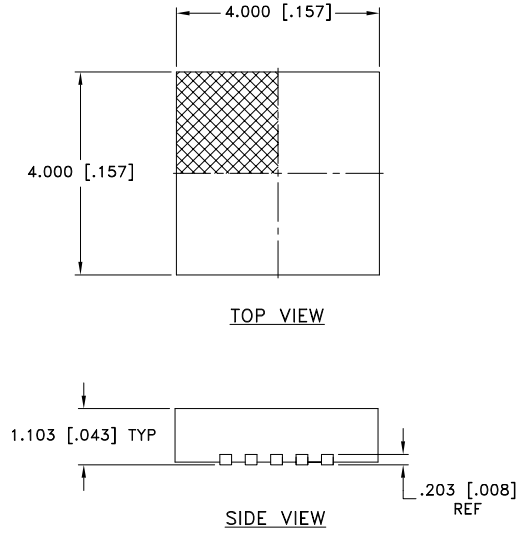

PCB Land Pattern

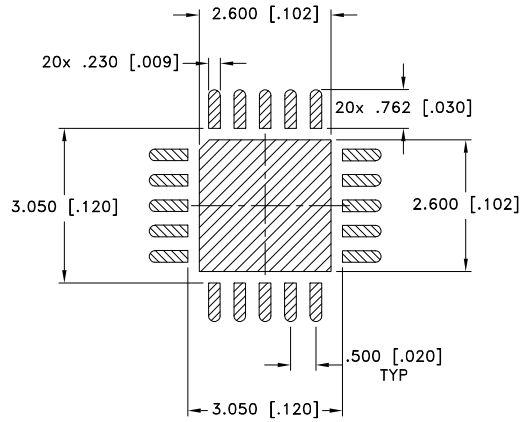

Suggested Layout,
Tolerance to be within ±0.050 [0.002]

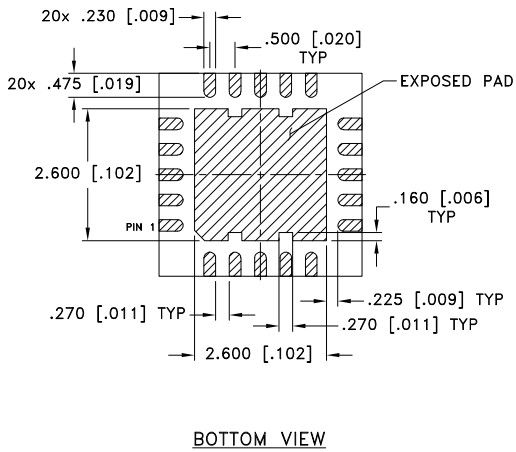

DENOTES METALLIZATION

Weight: .042 Grams

Dimensions are in mm [Inches]. Tolerances: 2 Pl. ± 0.254 [0.01]; 3 Pl. ± 0.127 [0.005] mm [inches]

PRODUCT MARKING

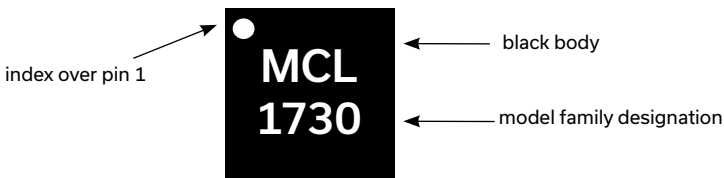

Marking may contain other features or characters for internal lot control



MMIC SURFACE MOUNT

Medium Power Amplifier **AVA-17303+**

50Ω 17 to 31.5 GHz High Linearity Driver

ADDITIONAL DETAILED INFORMATION IS AVAILABLE ON OUR DASHBOARD

[CLICK HERE](#)

Performance Data & Graphs	Data Graphs S-Parameter (S2P Files) Data Set (.zip file)
Case Style	DG983-4 Plastic package, exposed paddle, Lead Finish: Nickel-Palladium-Gold
RoHS Status	Compliant
Tape & Reel Standard quantities available on reel	F68 7" reels with 20, 50, 100, 200, 500, or 1000 devices 13" reels with 2000, 3000, or 4000 devices
Suggested Layout for PCB Design	PL-811
Evaluation Board	TB-AVA-17303C+ Gerber File
Environmental Ratings	ENV08T1
Product Handling	The use of no-clean solder is recommended. This package cannot be subjected to aqueous wash.

NOTES

- A. Performance and quality attributes and conditions not expressly stated in this specification document are intended to be excluded and do not form a part of this specification document.
- B. Electrical specifications and performance data contained in this specification document are based on Mini-Circuit's applicable established test performance criteria and measurement instructions.
- C. The parts covered by this specification document are subject to Mini-Circuits standard limited warranty and terms and conditions (collectively, "Standard Terms"); Purchasers of this part are entitled to the rights and benefits contained therein. For a full statement of the standard terms and the exclusive rights and remedies thereunder, please visit Mini-Circuits' website at www.minicircuits.com/terms/viewterm.html



Looking for pricing, stock, or lifecycle information?

Click below to explore more details on WIN SOURCE:

 [View AVA-17303+](#) on WIN SOURCE

 [Mini-Circuits](#) Information

Optimize Your Supply Chain with WIN SOURCE Solutions

-  Global Sourcing Solution
-  Obsolete Management
-  Cost Control Management
-  Shortage Management
-  Alternative Solution
-  Excess Inventory Management