

### General Description

The QPA9805 is a balanced amplifier module with embedded hybrid couplers to convert to single ended input and output ports. The module has an enable pin to allow for shutting down of the amplifier. The module requires minimal external components, which are VCC choke inductors and decoupling caps.

The QPA9805 provides 27.4 dBm P1dB with 20 dB gain and +43.2 dBm OIP3 across a wide frequency range of 600-1000 MHz to cover the 3GPP Bands 5, 6, 8, 12, 13, 14, 17 and 71. It is also operational up to 1200MHz. The linear driver amplifier is targeted for use in wireless infrastructure where high linearity, medium power and high integration is required. The balanced amplifier configuration provides very good input and output VSWR and is especially ideal as the output stage in a macro-cell transceiver board that connects to the high-power amplifier (HPA) board through a long cable or microstrip trace. The QPA9805 is packaged in a small 5x 5 mm leadless package that is internally matched to 50 Ω on all RF ports.

### Functional Block Diagram

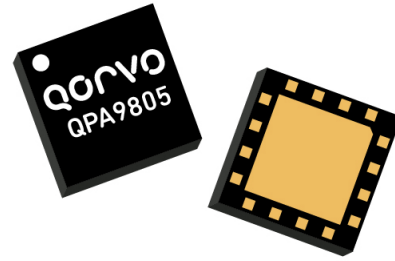
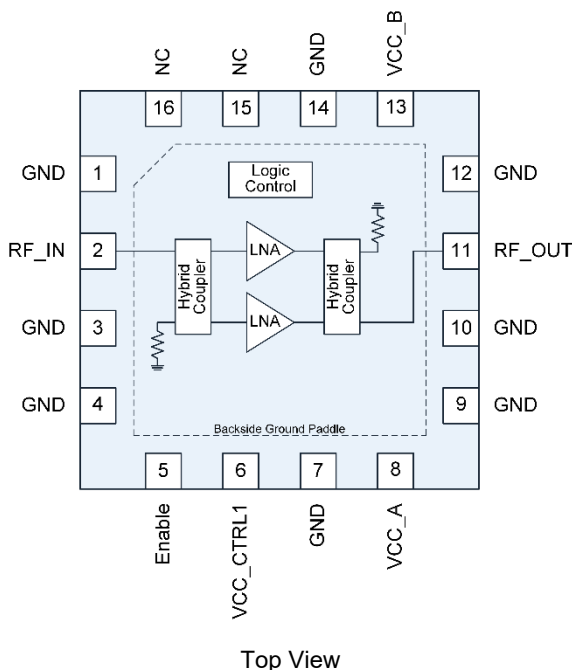

16 Pad 5 x 5 mm leadless SMT Package

### Product Features

- 600 – 1000 MHz; Operational up to 1200MHz
- Balanced Amplifier with integrated 3 dB hybrids
- Internally Matched 50 Ω Input / Output
- Shutdown Mode with 1.8V logic control
- 20 dB Gain
- +43.2 dBm OIP3
- +27.4 dBm P1dB
- Good gain flatness across Bands 5, 6, 8, 12, 13, 14, 17, and 71

### Applications

- Wireless Infrastructure
- Macro BTS Transceivers
- Booster Amps, Repeaters

### Ordering Information

Part No.	Description
QPA9805TR13	2,500 pieces on a 13" reel (standard)
QPA9805EVB-01	600-1200 MHz Evaluation Board

### Absolute Maximum Ratings

Parameter	Rating
Storage Temperature	-55 to +150 °C
RF Input Power, CW, 50 Ω, T=25 °C	+15 dBm
Supply Voltage (VCC)	+6 V
Enable Voltage (Enable)	VCC_CTRL1 + 0.5 V

Exceeding any one or a combination of the Absolute Maximum Rating conditions may cause permanent damage to the device. Extended application of Absolute Maximum Rating conditions to the device may reduce device reliability.

### Recommended Operating Conditions

Parameter	Min	Typ	Max	Units
Device Voltage (VCC_A&B)	+3.30	+5	+5.25	V
Enable (High)	+1.17	+1.8		V
Enable (Low)	-0.3		+0.63	V
T <sub>CASE</sub>	-40		+105	°C
T <sub>j</sub> for >10 <sup>6</sup> hours MTTF			+170	°C

Electrical specifications are measured at specified test conditions. Specifications are not guaranteed over all recommended operating conditions.

### Electrical Specifications

Parameter	Conditions <sup>(1)</sup>	Min	Typ	Max	Units
Operational Frequency Range		600		1200	MHz
Test Frequency			880		MHz
Gain		18.5	20	21.5	dB
Gain Slope (peak to peak)	F <sub>c</sub> ± 40 MHz		0.06		dB
	F <sub>c</sub> ± 100 MHz		0.1		dB
	F <sub>c</sub> ± 200 MHz		0.3		dB
Output IP3	P <sub>out</sub> = +12 dBm/tone, Δf = 1 MHz	+40.0	+43.2		dBm
Output P1dB		+26.0	+27.4		dBm
Noise Figure			4.5		dB
Input Return Loss			22		dB
Output Return Loss			22		dB
Current	I <sub>VCC_A</sub> (Pin 8) or I <sub>VCC_B</sub> (Pin 13)		115		mA
	I <sub>VCC_CTRL1</sub> (Pin 6)		18		mA
Total Current	I <sub>VCC_A</sub> , I <sub>VCC_B</sub> and I <sub>VCC_CTRL1</sub>		248	290	mA
Enable Time	50% Enable to 90% RF		250		ns
Disable Time	50% Enable to 10% RF		500		ns
Thermal Resistance, θ <sub>jc</sub>	Module (junction to backside ground paddle)			23.6	°C/W

Notes:

1. Test conditions unless otherwise noted: VCC\_A&B = VCC\_CTRL1 = +5.0 V, Enable = +1.8 V, Temp = +25 °C, 50 Ω system.

### Logic Table

Parameter	High	Low
Enable	Active	Shutdown

### Application Circuit Schematic and Layout

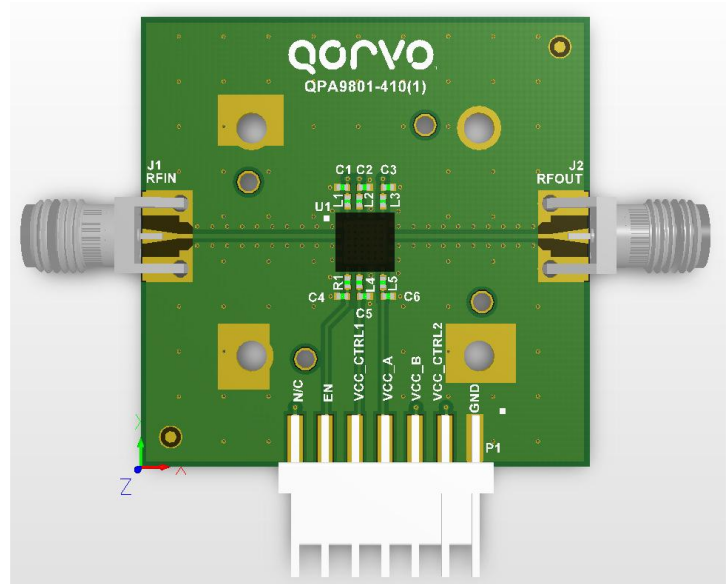
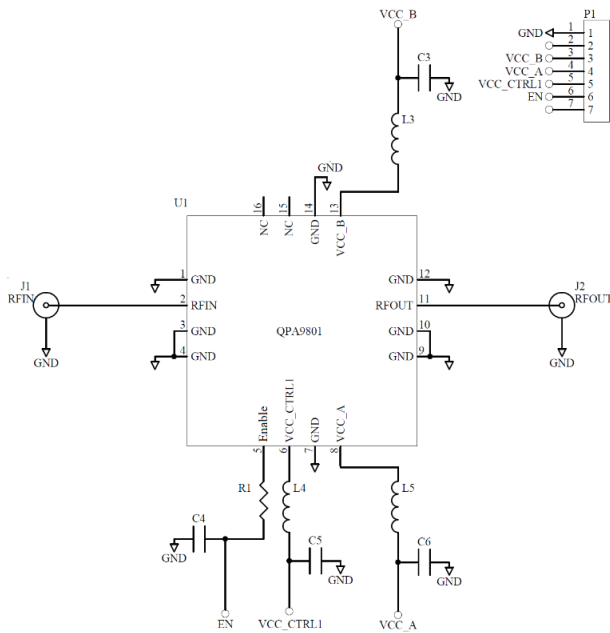

### Bill of Material – QPA9805EVB-01

Reference Des.	Value	Description	Manuf.	Part Number
-	-	Printed Circuit Board	-	-
U1	-	1/2 Watt Balanced Amplifier	Qorvo	QPA9805
L3, L5	68 nH	Inductor, wire wound	Coilcraft	0402CS-68NXGRW
R1, L4	0 Ω	Resistor, Chip, Jumper	Various	
C3, C6	1 μF	Capacitor, Chip, 10%, 10V, X5R	Various	
C5	100 pF	Capacitor, Chip, NPO, 5%, 50V, NPO/COG	Various	
C4	-	DNI		

**Typical Performance – VCC +5.0 V**

Parameter	Conditions <sup>(1)</sup>	Typical Value				Units
Frequency		617	728	869	960	MHz
Gain		19.8	19.9	19.9	19.9	dB
Gain Slope (peak to peak)	Fc ± 40 MHz	0.1	0.05	0.06	0.07	dB
	Fc ± 100 MHz	0.2	0.1	0.1	0.2	dB
	Fc ± 200 MHz	0.4	0.4	0.3	0.4	dB
Input Return Loss		24	34	22	18.5	dB
Output Return Loss		27	39	22	17.6	dB
Output IP3	Pout = +12 dBm/tone, Δf = 1 MHz	+43.3	+43.2	+43.2	+43.4	dBm
Output P1dB		+27.3	+27.3	+27.3	+27.3	dBm
Noise Figure		5.1	4.7	4.5	4.5	dB

**Notes:**

1. Test conditions unless otherwise noted: VCC\_A&B = VCC\_CTRL1 = +5.0V, Enable = +1.8V, Temp.=+25 °C

### Performance Plots – VCC +5.0 V

Test conditions unless otherwise noted: VCC\_A&B = VCC\_CTRL1 = +5V, Enable = +1.8 V, Temp.=+25 °C

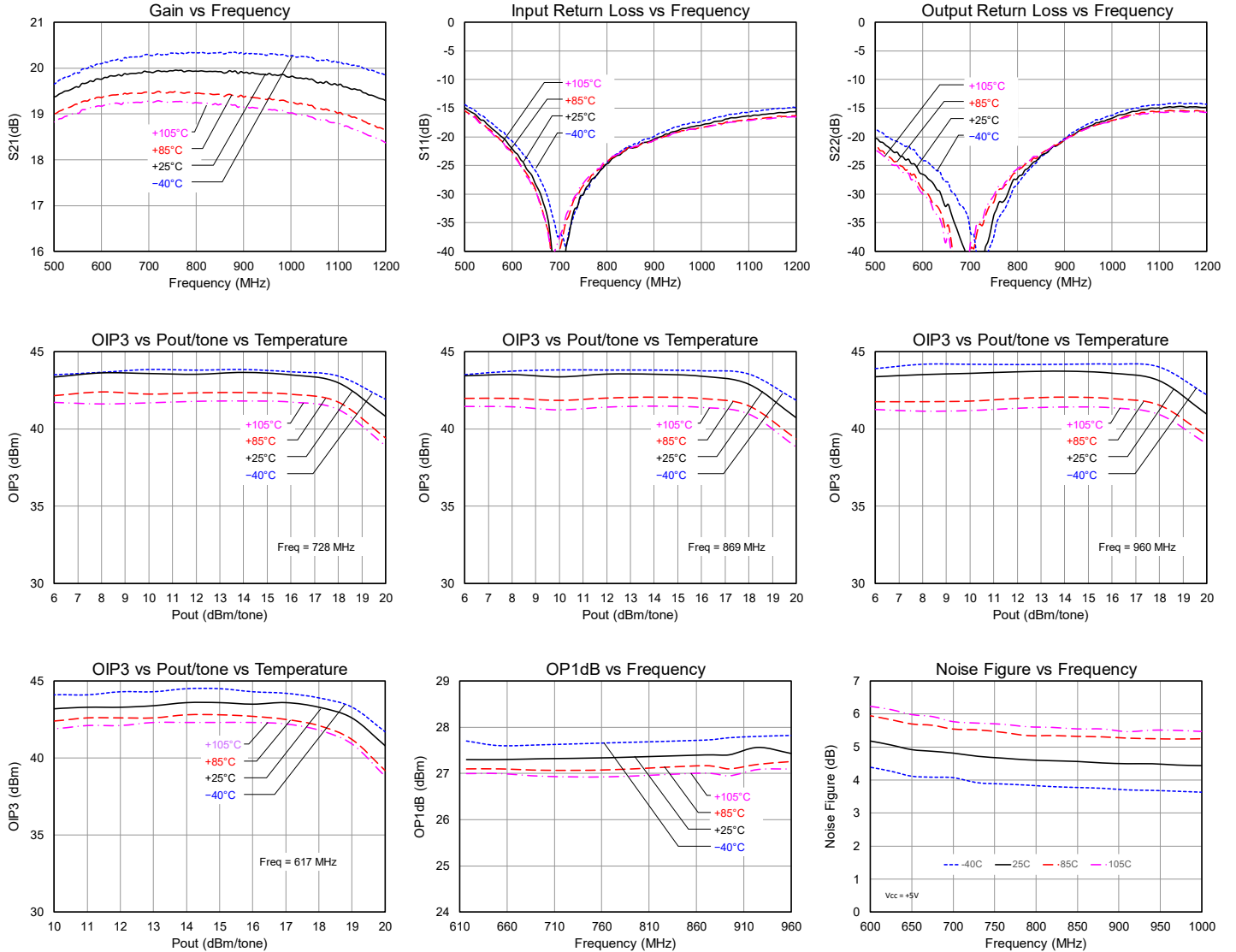

**Typical Performance –  $V_{CC} = +3.6\text{ V}$** 

Parameter	Conditions <sup>(1)</sup>	Typical Value				Units
Frequency		617	728	869	960	MHz
Gain		19.0	19.0	18.9	18.7	dB
Gain Slope (peak to peak)	Fc ± 40 MHz	0.08	0.05	0.06	0.07	dB
	Fc ± 100 MHz	0.1	0.1	0.1	0.2	dB
	Fc ± 200 MHz	0.3	0.4	0.3	0.4	dB
Input Return Loss		25	35	21	17.4	dB
Output Return Loss		30	40	22	17.8	dB
Output IP3	Pout = +10 dBm/tone, Δf = 1 MHz	+39.3	+39.1	+38.1	+37.9	dBm
Output P1dB		+23.8	+23.7	+23.9	+24.1	dBm
Noise Figure		3.4	3.2	3.2	3.3	dB

**Notes:**

1. Test conditions unless otherwise noted: VCC\_A&B = VCC\_CTRL1 = +3.6V, Enable = +1.8V, Temp.=+25 °C

### Performance Plots – $V_{CC} = +3.6\text{ V}$

Test conditions unless otherwise noted:  $V_{CC\_A\&B} = V_{CC\_CTRL1} = +3.6\text{V}$ , Enable = +1.8 V, Temp.=+25 °C

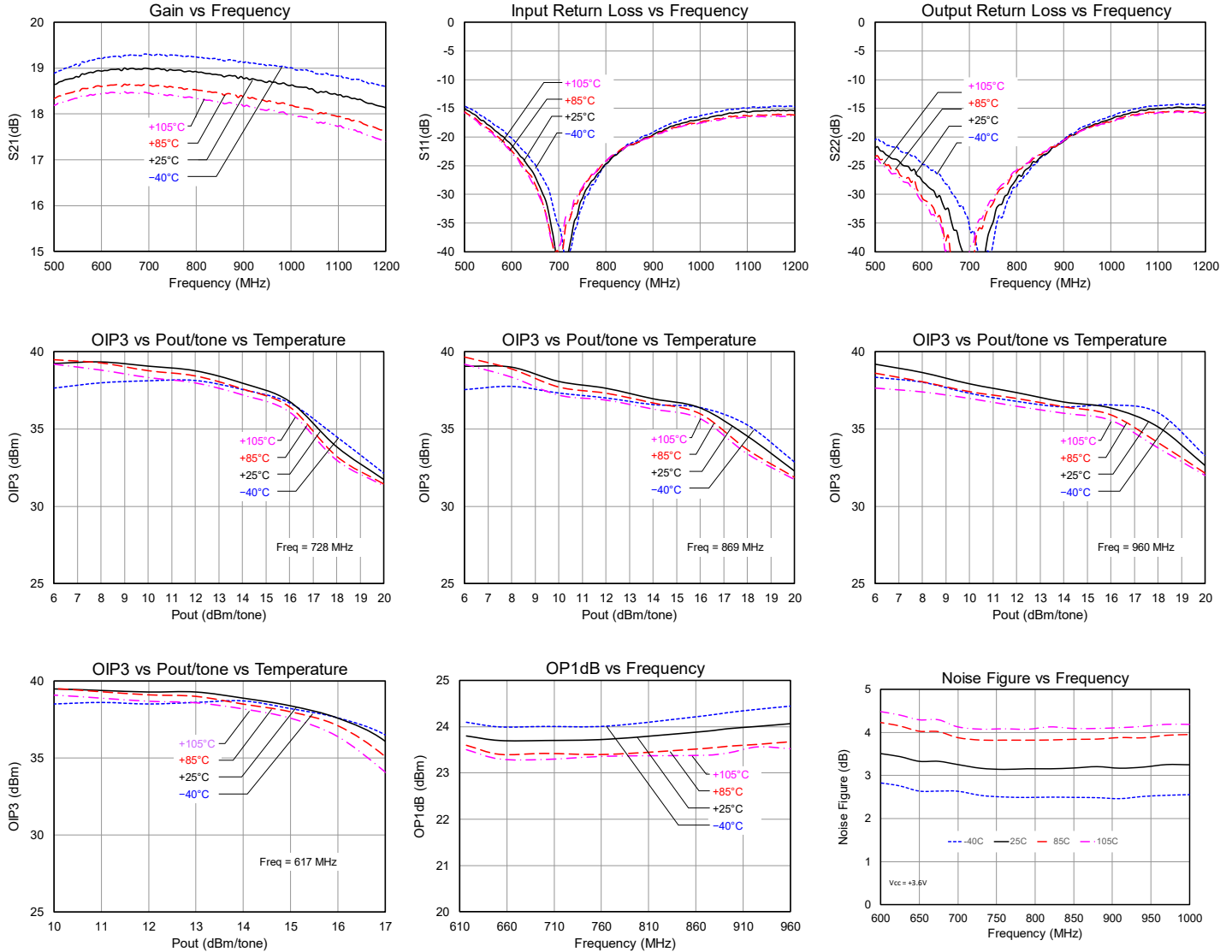

### Application Note – Reduced Bias Performance

The QPA9805 can be configured to be operated with lower bias current either by lowering  $V_{CC\_CTRL1}$  or by replacing L4 with a resistor and leaving  $V_{CC\_CTRL1} = V_{CC\_A\&B}$ . Typical performance is displayed below for various quiescent current settings.

### Typical Performance – Reduced Bias

VCC_CTRL1 (V)	I <sub>VCC_A&amp;B_Q</sub> (mA)	NF (dB)	P1dB (dBm)	OIP3 (dBm)
4.8	210	4.3	+27.2	+47.2
4.5	180	4.1	+27.1	+48.5
4.2	150	3.9	+26.9	+47.9
3.9	120	3.6	+26.8	+46.5
3.6	90	3.3	+26.8	+44.3

Frequency = 869 MHz

### Performance Plot – Reduced Bias

Test conditions unless otherwise noted:  $V_{CC\_A\&B} = +5.0\text{ V}$ ,  $I_{VCC\_A\&B} = \text{Vary}$ , Enable = +1.8 V, Temp. = +25 °C

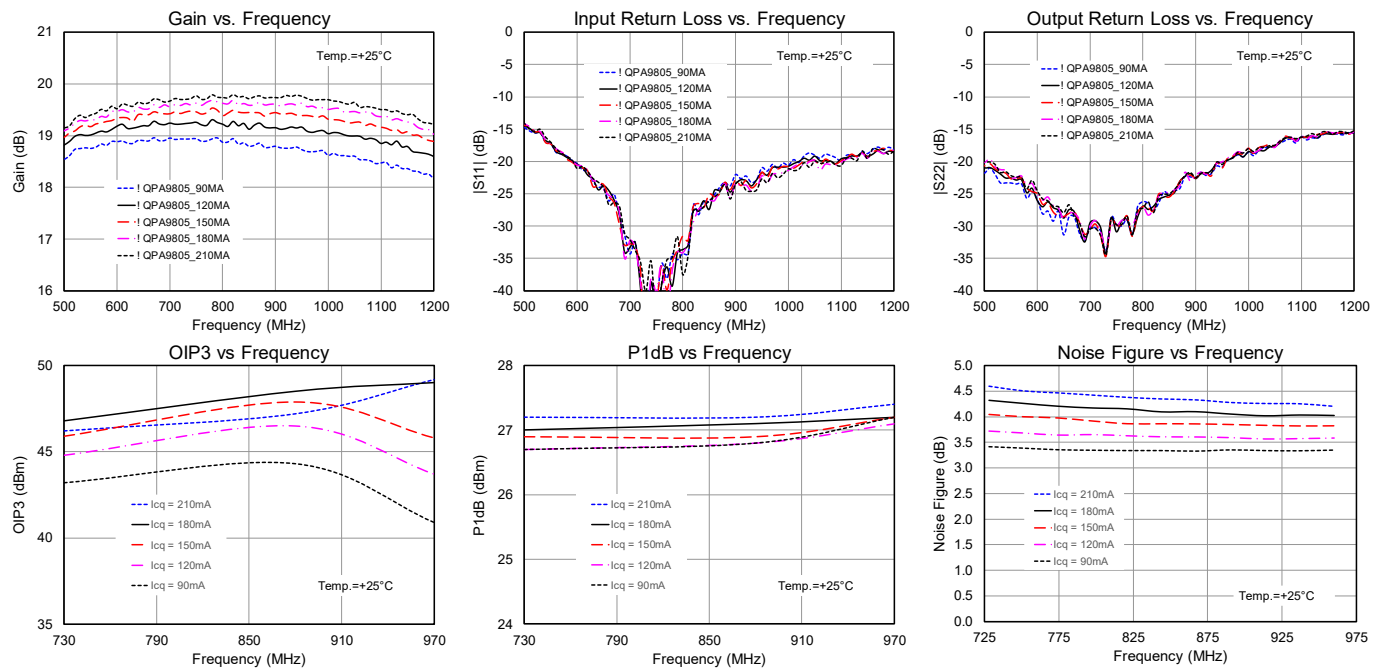

### Pin Configuration and Description

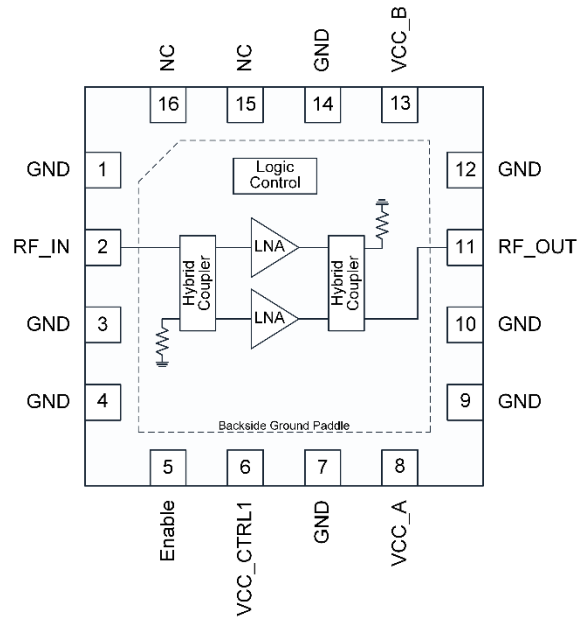

Top View

Pad No.	Label	Description
1, 3, 4, 7, 9, 10, 12, 14	GND	RF and DC Ground
2	RF_IN	RF Input, 50 Ω resistance presents, DC blocking capacitor required when cascading with non-zero DC voltage external circuitry
5	Enable	Enable Input, Logic “1” – Amplifiers ON; Logic “0” – Amplifiers OFF
6	VCC_CTRL1	DC Supply Voltage Input, BIAS control
8	VCC_A	DC Supply Voltage Input, Amplifier A
11	RF_OUT	RF Output, 50 Ω resistance presents, DC blocking capacitor required when cascading with non-zero DC voltage external circuitry
13	VCC_B	DC Supply Voltage Input, Amplifier B
15	NC	Not connected
16	NC	Not connected
Backside Paddle	-	RF/DC ground. See PCB Mounting Pattern for suggested footprint.

### Evaluation Board PCB Information

#### PC Board Layout

PCB Material (stack up):

- 1/2 oz. Cu top layer
- 0.008 Inch FR-4
- 1 oz. Cu middle layer 1
- .012 Inch FR-4
- 1 oz. Cu middle layer 2
- 0.008 Inch FR-4
- 1/2 oz. Cu bottom layer
- Finished board thickness is 0.034±.003

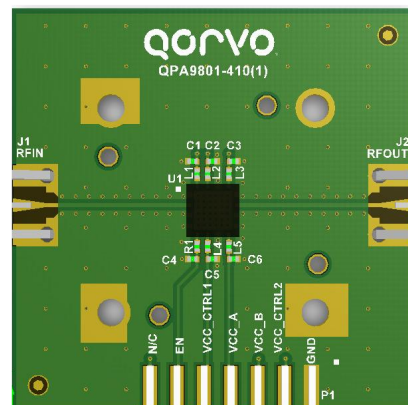

### Package Marking and Dimensions

Marking: Part Number – QPA9805

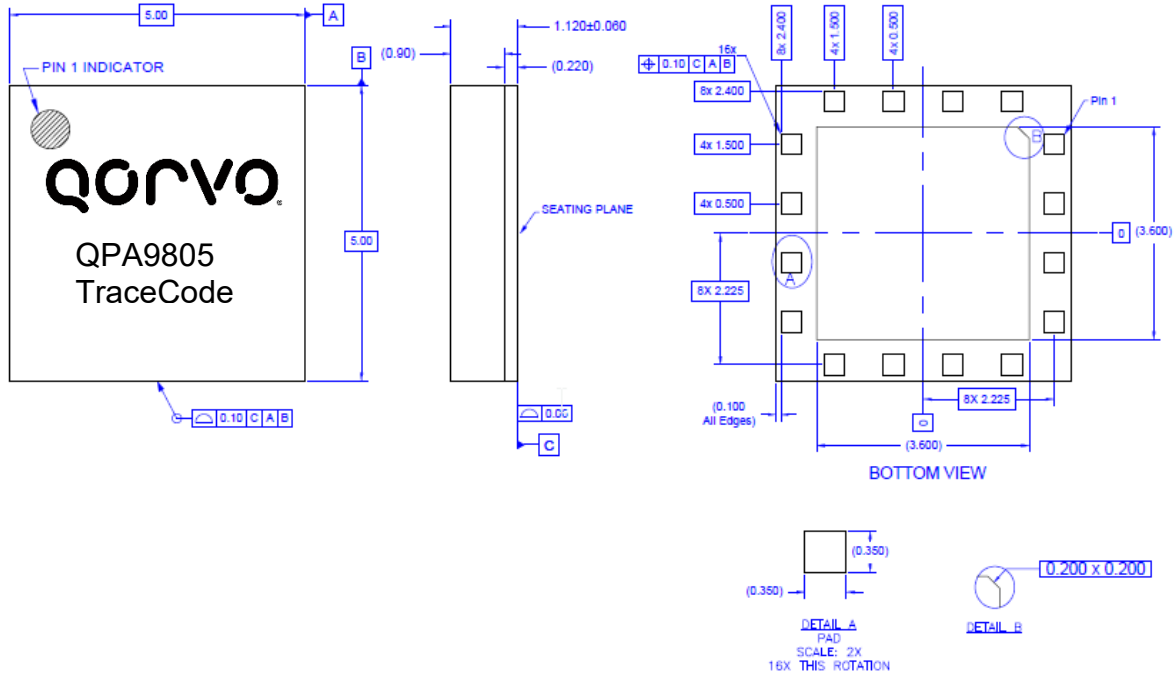

**Notes:**

1. All dimensions are in millimeters. Angles are in degrees.
2. The terminal #1 identifier and terminal numbering conform to JESD 95-1 SPP-012.
3. Contact plating: ENEPIG

### PCB Mounting Pattern

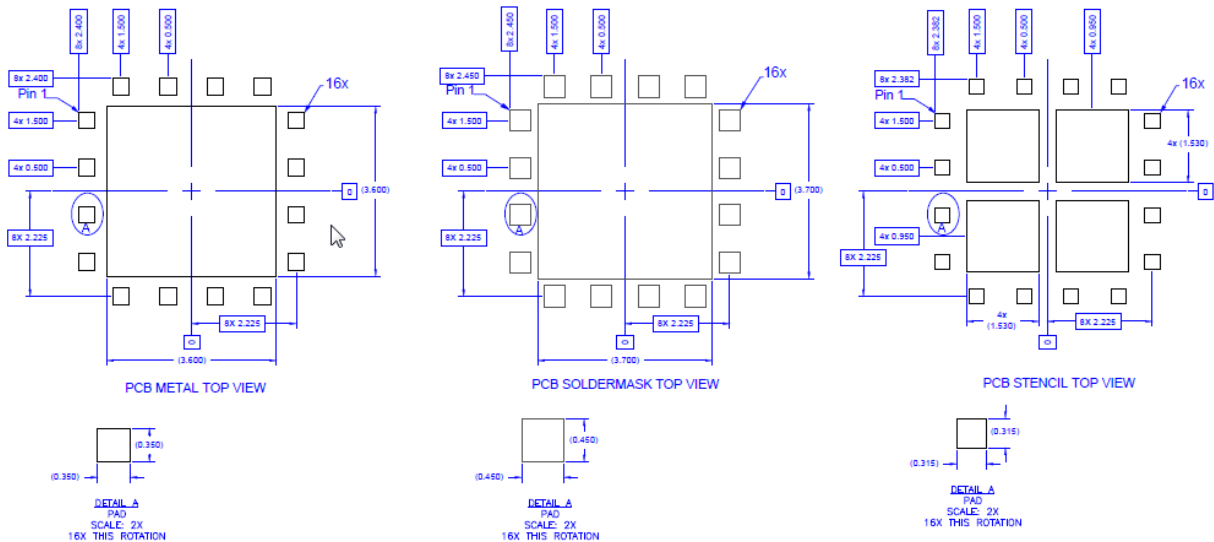

**Notes:**

1. All dimensions are in millimeters. Angles are in degrees.
2. Use 1 oz. copper minimum for top and bottom layer metal.
3. Vias are required under the backside paddle of this device for proper RF/DC grounding and thermal dissipation. We recommend a 0.35mm (#80/.0135") diameter bit for drilling via holes and a final plated thru diameter of 0.25 mm (0.010").
4. Ensure good package backside paddle solder attach for reliable operation and best electrical performance.

Tape and Reel Information – Carrier and Cover Tape Dimensions

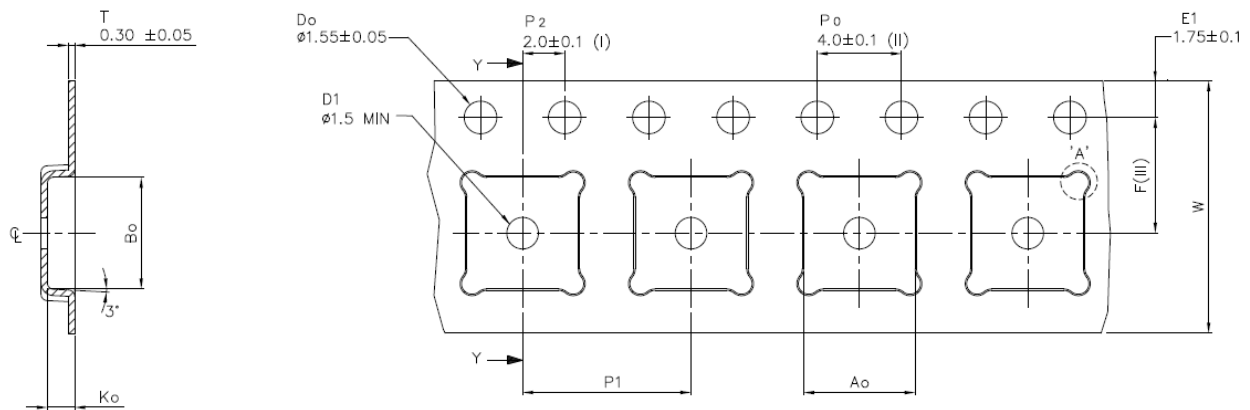
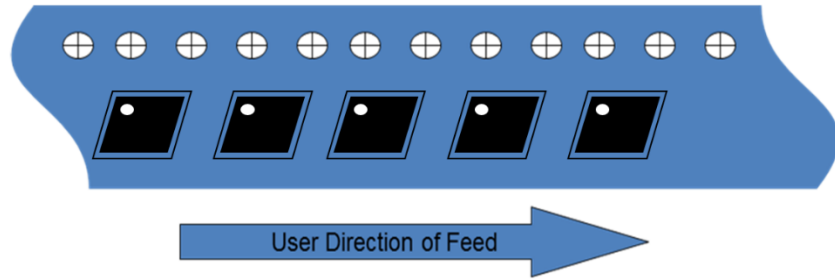

SECTION Y-Y

GENERAL TOLERANCE: ±0.2

Ao	5.30	+/-	0.1
Bo	5.30	+/-	0.1
Ko	1.30	+/-	0.1
F	5.50	+/-	0.1
P1	8.00	+/-	0.1
W	12.00	+/-	0.3

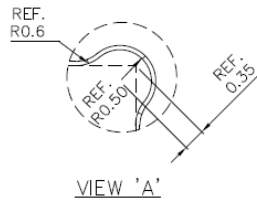

- (I) Measured from centreline of sprocket hole to centreline of pocket.
- (II) Cumulative tolerance of 10 sprocket holes is ± 0.20 .
- (III) Measured from centreline of sprocket hole to centreline of pocket.
- (IV) Other material available.

ALL DIMENSIONS IN MILLIMETRES UNLESS OTHERWISE STATED.

Feature	Measure	Symbol	Size (in)	Size (mm)
Cavity	Length	A0	0.209	5.30
	Width	B0	0.209	5.30
	Depth	K0	0.051	1.30
	Pitch	P1	0.315	8.00
Centerline Distance	Cavity to Perforation - Length Direction	P2	0.079	2.00
	Cavity to Perforation - Width Direction	F	0.217	5.50
Cover Tape	Width (Reference only)	C	0.362	9.20
Carrier Tape	Width	W	0.472	12.00

### Tape and Reel Information – Reel Dimensions

Standard T/R size = 2,500 pieces on a 13" reel.

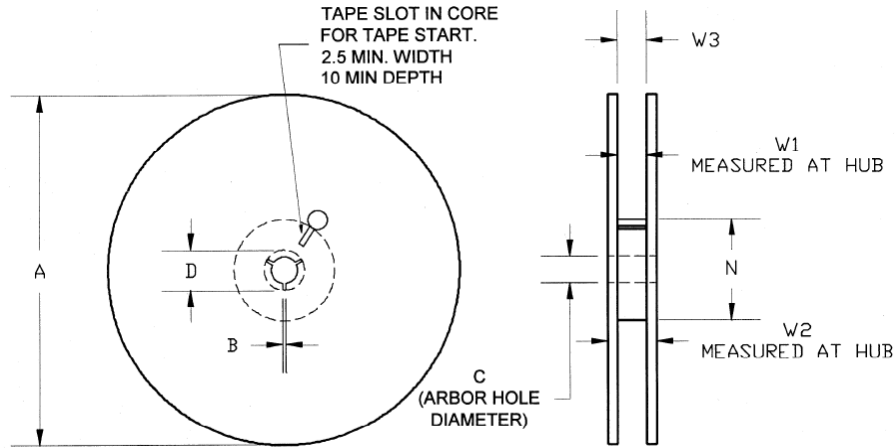

Feature	Measure	Symbol	Size (in)	Size (mm)
Flange	Diameter	A	12.992	330.0
	Thickness	W2	0.717	18.2
	Space Between Flange	W1	0.504	12.8
Hub	Outer Diameter	N	4.016	102.0
	Arbor Hole Diameter	C	0.512	13.0
	Key Slit Width	B	0.079	2.0
	Key Slit Diameter	D	0.787	20.0

### Tape and Reel Information – Tape Length and Label Placement

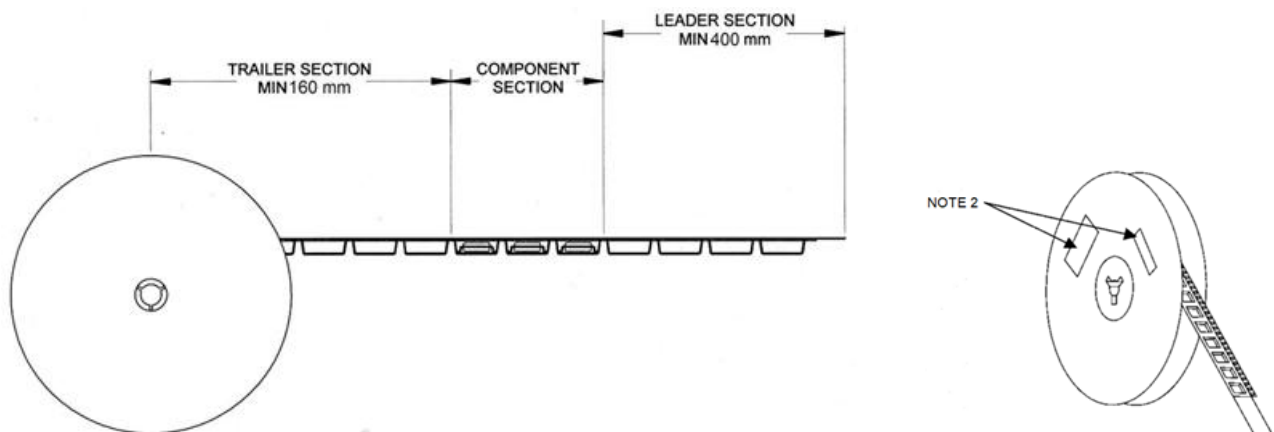

**Notes:**

1. Empty part cavities at the trailing and leading ends are sealed with cover tape. See EIA 481-1-A.
2. Labels are placed on the flange opposite the sprockets in the carrier tape.

## Handling Precautions

Parameter	Rating	Standard
ESD – Human Body Model (HBM)	Class 1B	ESDA / JEDEC JS-001-2012
ESD – Charged Device Model (CDM)	Class C3	JEDEC JESD22-C101F
MSL – Moisture Sensitivity Level	Level 3	IPC/JEDEC J-STD-020



Caution!  
ESD-Sensitive Device

## Solderability

Compatible with both lead-free (260°C max. reflow temp.) and tin/lead (245°C max. reflow temp.) soldering processes.

Solder profiles available upon request.

Contact plating: ENEPIG (*Plating thickness: Ni 0.40±0.10µm; Pd 0.145±0.035µm; Au 0.095±0.025µm*)

## RoHS Compliance

This part is compliant with EU 2011/65/EU RoHS directive (Restrictions on the Use of Certain Hazardous Substances in Electrical and Electronic Equipment) as amended by Directive 2015/863/EU.

This product also has the following attributes:

- Halogen Free (Chlorine, Bromine)
- Antimony Free
- TBBP-A (C<sub>15</sub>H<sub>12</sub>Br<sub>4</sub>O<sub>2</sub>) Free
- PFOS Free
- SVHC Free

## Contact Information

For the latest specifications, additional product information, worldwide sales and distribution locations:

Tel: 1-844-890-8163

Web: [www.qorvo.com](http://www.qorvo.com)

Email: [customer.support@qorvo.com](mailto:customer.support@qorvo.com)

## Important Notice

The information contained herein is believed to be reliable; however, Qorvo makes no warranties regarding the information contained herein and assumes no responsibility or liability whatsoever for the use of the information contained herein. All information contained herein is subject to change without notice. Customers should obtain and verify the latest relevant information before placing orders for Qorvo products. The information contained herein or any use of such information does not grant, explicitly or implicitly, to any party any patent rights, licenses, or any other intellectual property rights, whether with regard to such information itself or anything described by such information. **THIS INFORMATION DOES NOT CONSTITUTE A WARRANTY WITH RESPECT TO THE PRODUCTS DESCRIBED HEREIN, AND QORVO HEREBY DISCLAIMS ANY AND ALL WARRANTIES WITH RESPECT TO SUCH PRODUCTS WHETHER EXPRESS OR IMPLIED BY LAW, COURSE OF DEALING, COURSE OF PERFORMANCE, USAGE OF TRADE OR OTHERWISE, INCLUDING THE IMPLIED WARRANTIES OF MERCHANTABILITY AND FITNESS FOR A PARTICULAR PURPOSE.**

Without limiting the generality of the foregoing, Qorvo products are not warranted or authorized for use as critical components in medical, life-saving, or life-sustaining applications, or other applications where a failure would reasonably be expected to cause severe personal injury or death.

Copyright 2025 © Qorvo, Inc. | Qorvo is a registered trademark of Qorvo, Inc.

## Looking for pricing, stock, or lifecycle information?

Click below to explore more details on WIN SOURCE:

 [View QPA9805TR13 on WIN SOURCE](#)

 [Qorvo US Inc. Information](#)

## Optimize Your Supply Chain with WIN SOURCE Solutions

-  Global Sourcing Solution
-  Obsolete Management
-  Cost Control Management
-  Shortage Management
-  Alternative Solution
-  Excess Inventory Management