

General Description

The TQP9224 is a high-linearity three-stage power amplifier in a low-cost surface-mount package with on-chip bias control and temperature control circuits, suitable for small cell or enterprise Femto cell base station applications.

The TQP9224 provides 36.7 dB high gain and -50 dBc ACLR at +24 dBm linear power using a 20 MHz LTE signal over the 2.3–2.4 GHz frequency range covering 3GPP Bands 30, 40.

The TQP9224 integrates three high performance amplifier stages to allow for a compact system design and requires very few external components for operation. The amplifier is bias adjustable allowing the amplifier's power consumption to be optimized for specific performance requirements. The TQP9224 is available in a lead-free/RoHS-compliant 7 x 7 mm surface mount package.

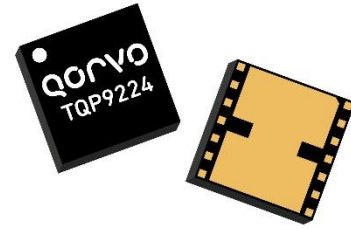

14 Pin 7 x 7 mm Leadless SMT Package

Product Features

- 2.3 – 2.4 GHz Frequency Range
- Fully integrated, 3-Stage Power Amplifier
- Internally Matched 50 Ω Input/Output
- -50 dBc ACLR at $P_{avg} = +24$ dBm
- 36.7 dB Gain
- 14% PAE at +24 dBm
- 204 mA Quiescent Current
- On-chip Control Bias and Temp. Comp Circuit
- RoHS compliant
- Covers Band 30, 40

Functional Block Diagram

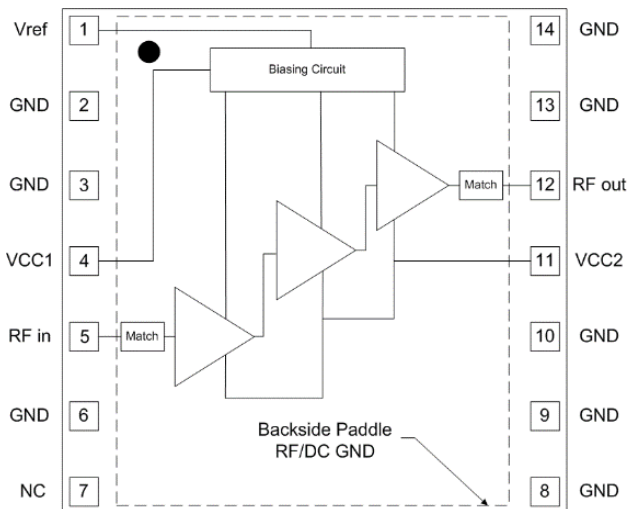

Top View

Applications

- Small Cell / Picocell
- Enterprise Femtocell
- Customer Premises Equipment (CPE)
- Data Cards and Terminals
- Distributed Antenna Systems (DAS)
- Booster Amps, Repeaters

Ordering Information

Part No.	Description
TQP9224TR13	2,500 pieces on a 13" reel (standard)
TQP9224PCB401	2.3–2.4 GHz Evaluation Board

Absolute Maximum Ratings

Parameter	Rating
Storage Temperature	-55 to +150 °C
RF Input Power, CW, 50Ω, T=+25 °C	+9 dBm
Supply Voltage (V _{CC})	6 V
V _{REF}	+3.5 V

Exceeding any one or a combination of the Absolute Maximum Rating conditions may cause permanent damage to the device. Extended application of Absolute Maximum Rating conditions to the device may reduce device reliability.

Recommended Operating Conditions

Parameter	Min	Typ	Max	Units
V _{CC1} , V _{CC2}	+3.6	+4.5	+5.25	V
V _{ref}	+2.75	+2.85	+2.95	V
T _{CASE}	-40		+85	°C
T _j at T _{CASE} max			+156	°C

Electrical specifications are measured at specified test conditions. Specifications are not guaranteed over all recommended operating conditions.

Electrical Specifications

Parameter	Conditions ⁽¹⁾	Min	Typ	Max	Units
Frequency Range		2300		2400	MHz
Test Frequency			2350		MHz
Gain		34	36.7	40	dB
Input Return Loss			16		dB
Output Return Loss			8		dB
Output P1dB			+33.6		dBm
ACLR	P _{OUT} = +24 dBm, 20 MHz LTE E-TM1.1, 9.5 dB PAR		-50	-45	dBc
Power Added Efficiency	P _{OUT} = +24 dBm, 20 MHz LTE E-TM1.1, 9.5 dB PAR	13	14		%
Spurious Output Level	P _{OUT} = +24 dBm, 10:1 VSWR		<60		dBc
VSWR survivability	No permanent degradation or failure	10:1			-
Quiescent Current, I _{CQ}	V _{CC1} + V _{CC2}	160	204	250	mA
Reference Current, I _{ref}	Temp = -40°C to +85°C, V _{REF} = +2.85V		8.7		mA
Leakage Current	V _{CC} = +4.5 V, V _{REF} = 0 V		1.5	8	μA
Operational Current, I _{CC}	P _{OUT} = +24 dBm		390	430	mA
Switching Speed	0% V _{ref} to 90% RF Rise time		1.7	2.5	μs
	100% V _{ref} to 10% RF Fall time		0.87	1	μs
Harmonics	2F ₀ at +24dBm, CW signal		-40	-35	dBc
	3F ₀ at +24dBm, CW signal		-54	-49	dBc
	4F ₀ at +24dBm, CW signal		-61	-56	dBc
Thermal Resistance, θ _{Jc}	Module (junction to case)			35.4	°C/W

Notes:

1. Test conditions unless otherwise noted: V_{CC1} = V_{CC2} = +4.5 V, V_{REF} = +2.85V, Temp = +25 °C, 50 Ω system.

Evaluation Board (TQP9224-PCB)

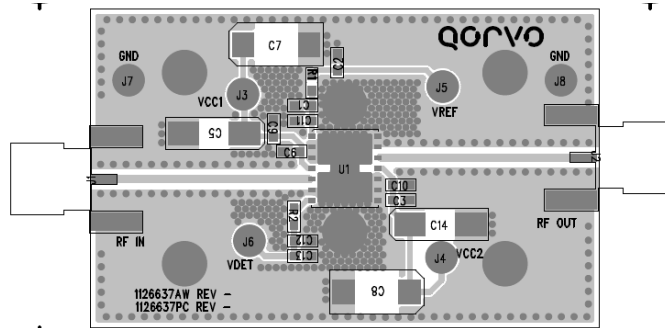
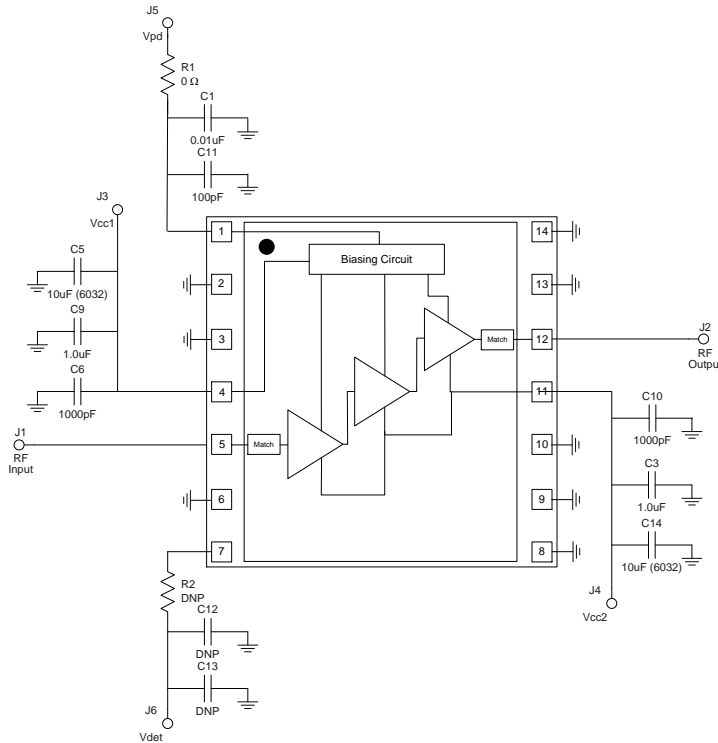

Bill of Material – TQP9224-PCB

Reference Des.	Value	Description	Manuf.	Part Number
n/a	n/a	Printed Circuit Board		
U1	n/a	High Linearity 0.25 W Power Amplifier	Qorvo	TQP9224
R1	0 Ω	Resistor, Chip, 0603, 5%	various	
C1	0.01 uF	Capacitor, Chip, 0603, 5%	various	
C11	100 pF	Capacitor, Chip, 0603, 5%	various	
C3, C9	0.1 uF	Capacitor, Chip, 0603, 5%	various	
C5, C14	10 uF	Capacitor, Chip, 6032, 10%, Tantalum	various	
C6, C10	1000 pF	Capacitor, Chip, 0603, NPO/COG, 5%	various	

Performance Plots

Test conditions unless otherwise noted: $V_{CC1} = V_{CC2} = +4.5V$, $V_{REF} = +2.85V$, $I_{CQ} = 204mA$, $I_{REF} = 8.7mA$, $Temp. = +25^{\circ}C$

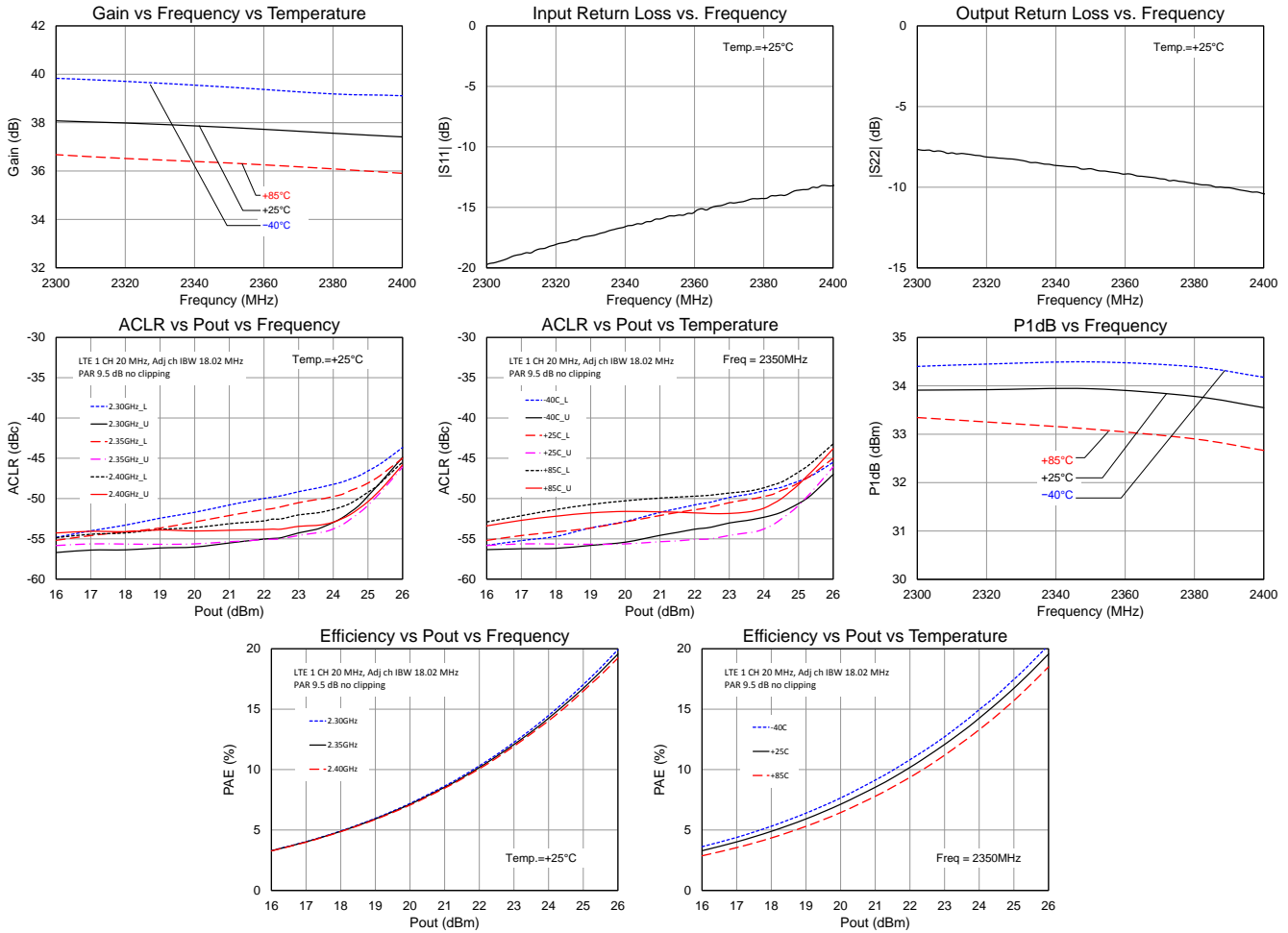

Pin Configuration and Description

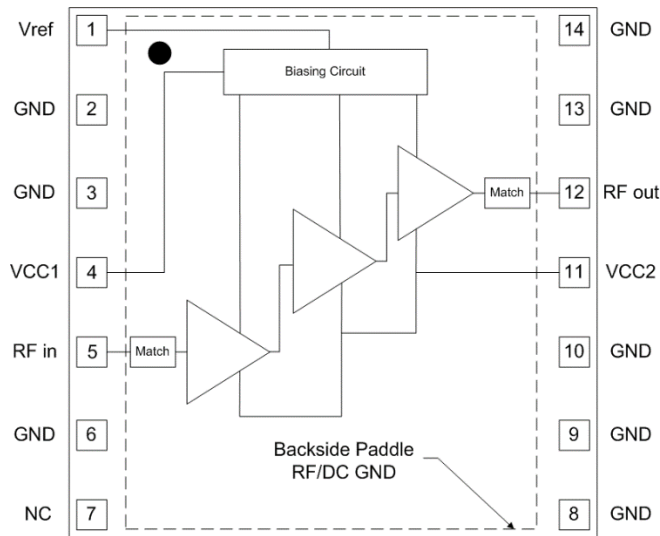

Top View

Pad No.	Label	Description
1	V _{REF}	Sets the bias current for the amplifiers. It can also be used to power down the device.
2, 3, 6, 8, 9, 10, 13, 14	GND	RF and DC ground.
4	V _{CC1}	Voltage supply for the active bias circuitry.
5	RFin	RF input pin. The DC is internally blocked at this pin.
7	NC	No internal connection.
11	V _{CC2}	DC voltage supply connection for AMP1, 2, 3.
12	RFout	RF output pin. The DC is internally blocked at this pin.
Backside Paddle	RF/DC GND	RF/DC ground. See PCB Mounting Pattern for suggested footprint.

Evaluation Board PCB Information

Qorvo PCB 1126637 Material and Stack-up

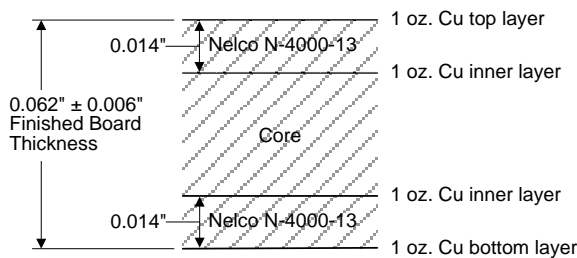

50 ohm line dimensions: width = .028"
spacing = .028".

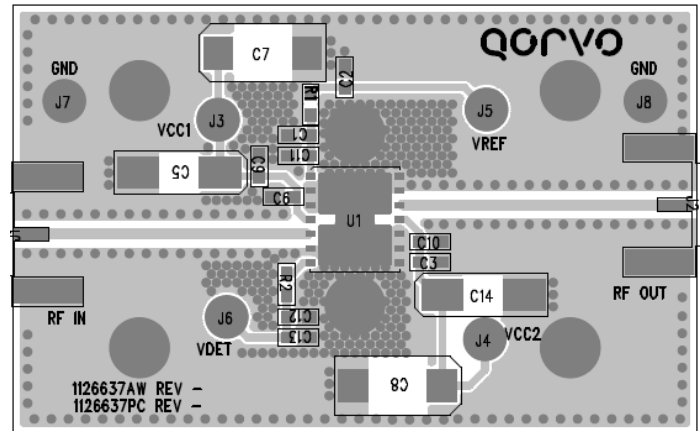

Package Marking and Dimensions

Marking: Part Number – TQP9224
Trace Code

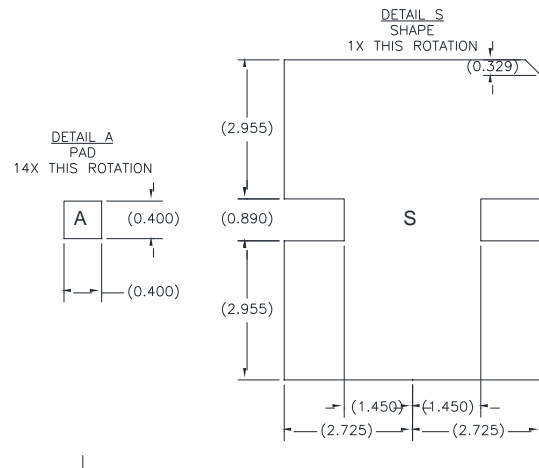
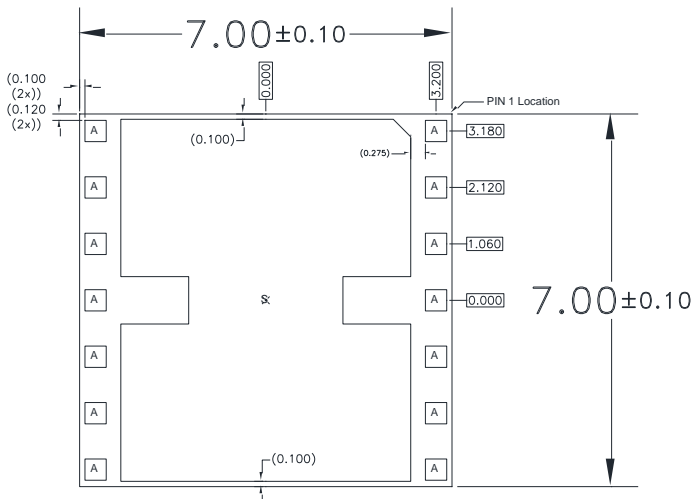
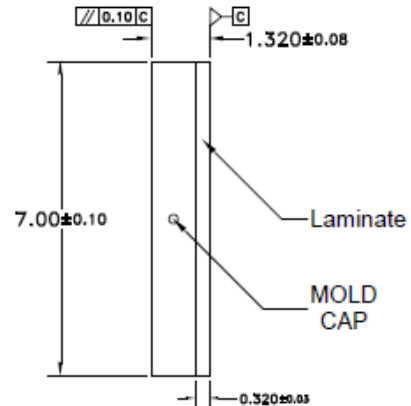
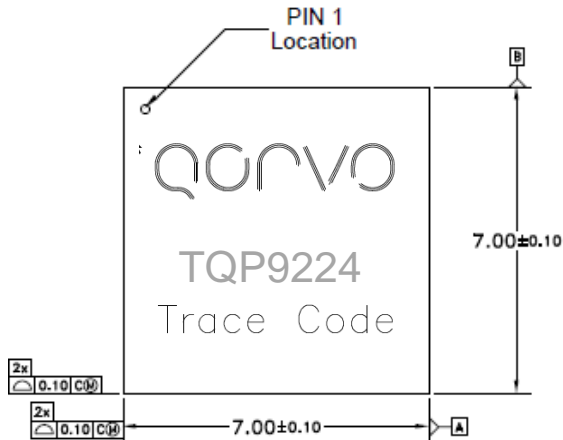

Notes:

1. All dimensions are in millimeters. Angles are in degrees.
2. Dimension and tolerance formats conform to ASME Y14.4M-1994.
3. The terminal #1 identifier and terminal numbering conform to JESD 95-1 SPP-012.

PCB Mounting Pattern

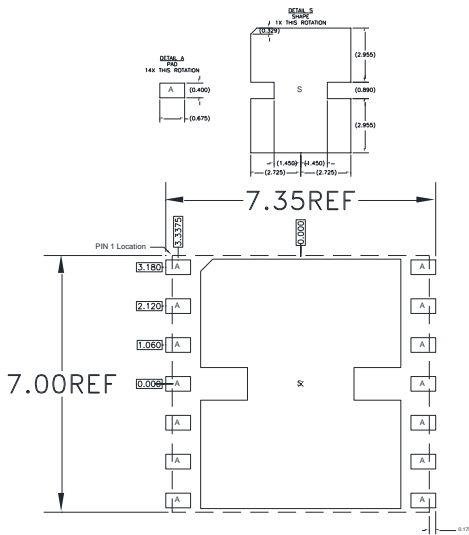

RECOMMENDED
LAND PATTERN

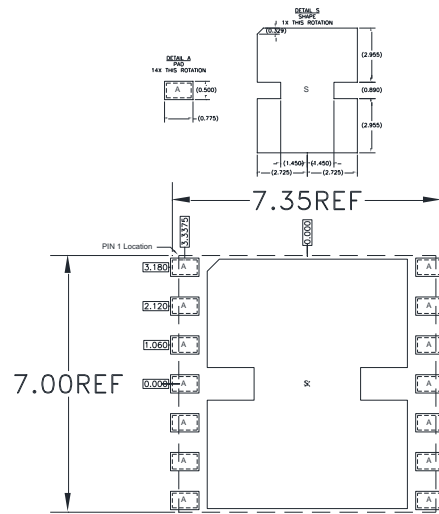

RECOMMENDED
LAND PATTERN MASK

Notes:

1. All dimensions are in millimeters. Angles are in degrees.
2. Use 1 oz. copper minimum for top and bottom layer metal.
3. Vias are required under the backside paddle of this device for proper RF/DC grounding and thermal dissipation. We recommend a 0.35mm (#80/.0135") diameter bit for drilling via holes and a final plated thru diameter of 0.25 mm (0.10").
4. Ensure good package backside paddle solder attach for reliable operation and best electrical performance.

Handling Precautions

Parameter	Rating	Standard
ESD – Human Body Model (HBM)	Class 2	ESDA / JEDEC JS-001-2012
ESD – Charged Device Model (CDM)	Class C3	JEDEC JESD22-C101F
MSL – Moisture Sensitivity Level	Level 3	IPC/JEDEC J-STD-020



Caution!
ESD-Sensitive Device

Solderability

Compatible with both lead-free (260°C max. reflow temp.) and tin/lead (245°C max. reflow temp.) soldering processes.

Solder profiles available upon request.

Contact plating: Electrolytic plated Au over Ni

RoHS Compliance

This part is compliant with EU 2002/95/EC RoHS directive (Restrictions on the Use of Certain Hazardous Substances in Electrical and Electronic Equipment). This product also has the following attributes:

- Product uses RoHS Exemption 7c-I to meet RoHS Compliance requirements
- Halogen Free (Chlorine, Bromine)
- Antimony Free
- TBBP-A (C₁₅H₁₂Br₄O₂) Free
- PFOS Free
- SVHC Free

Contact Information

For the latest specifications, additional product information, worldwide sales and distribution locations:

Tel: 1-844-890-8163

Web: www.qorvo.com

Email: customer.support@qorvo.com

For technical questions and application information: **Email:** appsupport@qorvo.com

Important Notice

The information contained herein is believed to be reliable; however, Qorvo makes no warranties regarding the information contained herein and assumes no responsibility or liability whatsoever for the use of the information contained herein. All information contained herein is subject to change without notice. Customers should obtain and verify the latest relevant information before placing orders for Qorvo products. The information contained herein or any use of such information does not grant, explicitly or implicitly, to any party any patent rights, licenses, or any other intellectual property rights, whether with regard to such information itself or anything described by such information. **THIS INFORMATION DOES NOT CONSTITUTE A WARRANTY WITH RESPECT TO THE PRODUCTS DESCRIBED HEREIN, AND QORVO HEREBY DISCLAIMS ANY AND ALL WARRANTIES WITH RESPECT TO SUCH PRODUCTS WHETHER EXPRESS OR IMPLIED BY LAW, COURSE OF DEALING, COURSE OF PERFORMANCE, USAGE OF TRADE OR OTHERWISE, INCLUDING THE IMPLIED WARRANTIES OF MERCHANTABILITY AND FITNESS FOR A PARTICULAR PURPOSE.**

Without limiting the generality of the foregoing, Qorvo products are not warranted or authorized for use as critical components in medical, life-saving, or life-sustaining applications, or other applications where a failure would reasonably be expected to cause severe personal injury or death.

Copyright 2018 © Qorvo, Inc. | Qorvo is a registered trademark of Qorvo, Inc.

Looking for pricing, stock, or lifecycle information?

Click below to explore more details on WIN SOURCE:

 [View TQP9224TR13 on WIN SOURCE](#)

 [Qorvo US Inc. Information](#)

Optimize Your Supply Chain with WIN SOURCE Solutions

-  Global Sourcing Solution
-  Obsolete Management
-  Cost Control Management
-  Shortage Management
-  Alternative Solution
-  Excess Inventory Management