



PIC16F1829LIN

20-Pin, 8-bit Flash LIN/J2602 Microcontroller

Cross-Referenced Material:

This data sheet refers heavily on the following Microchip data sheets:

- “PIC16(L)F1825/1829 Data Sheet” (DS41440)
- “MCP2021A/2A, LIN Transceiver with Voltage Regulator Data Sheet” (DS22298)

Please have these documents available when reading this device specification. Only deviations from the data sheets listed above will be noted.

High-Performance RISC CPU:

- Only 49 Instructions to Learn:
 - All single-cycle instructions except branches
- Operating Speed:
 - DC – 32 MHz oscillator/clock input
 - DC – 125 ns instruction cycle
- 16 Kbytes Linear Program Memory Addressing
- 1024 bytes Linear Data Memory Addressing
- Interrupt Capability with Automatic Context Saving
- 16-Level Deep Hardware Stack with Optional Overflow/Underflow Reset
- Direct, Indirect and Relative Addressing modes:
 - Two full 16-bit File Select Registers (FSRs)
 - FSRs can read Program and Data memory

Flexible Oscillator Structure:

- Precision 32 MHz Internal Oscillator Block:
 - Factory calibrated to $\pm 1\%$, typical
 - Software selectable frequencies range of 31 kHz to 32 MHz
- Four Crystal modes up to 32 MHz
- Three External Clock modes up to 32 MHz
- 4x Phase Lock Loop (PLL)
- Fail-Safe Clock Monitor:
 - Allows for safe shutdown if peripheral clock stops
- Two-Speed Oscillator Start-up
- Reference Clock Module:
 - Programmable clock output frequency and duty-cycle

Special Microcontroller Features:

- Self-Programmable under Software Control
- Power-on Reset (POR), Power-up Timer (PWRT) and Oscillator Start-up Timer (OST)
- Programmable Brown-out Reset (BOR)
- Extended Watchdog Timer (WDT)
- In-Circuit Serial Programming™ (ICSP™) via Two Pins
- In-Circuit Debug (ICD) via Two Pins
- Enhanced Low-Voltage Programming (LVP)
- Operating Voltage Range of the Microcontroller:
 - 2.3V-5.5V
- Programmable Code Protection
- Power-Saving Sleep mode

Analog Features:

- Analog-to-Digital Converter (ADC) Module:
 - 10-bit resolution
 - Nine analog input channels
 - Conversion available during Sleep
- Analog Comparator Module:
 - Two rail-to-rail analog comparators
 - Power mode control
 - Software controllable hysteresis
- Voltage Reference Module:
 - Fixed Voltage Reference (FVR) with multiple output levels
 - 5-bit rail-to-rail resistive DAC with positive and negative reference selection

Peripheral Features:

- 12 Digital I/O Pins and one Input-only Pin:
 - High current sink/source 25 mA/25 mA
 - Individually programmable weak pull-ups
 - Individually programmable Interrupt-on-change pins
- Timer0: 8-Bit Timer/Counter with 8-Bit Prescaler
- Enhanced Timer1:
 - 16-bit timer/counter with prescaler
 - External Gate Input mode
 - Dedicated, low-power 32 kHz oscillator driver
- Three Timer2 types: 8-Bit Timer/Counter with 8-Bit Period Register, Prescaler and Postscaler
- Two Capture, Compare, PWM (CCP) Modules (one is internal only)
- Two Enhanced CCP (ECCP) Modules:
 - Software-selectable time bases
 - Auto-shutdown and auto-restart
 - PWM steering

PIC16F1829LIN

Peripheral Features: (Continued)

- Enhanced Universal Synchronous Asynchronous Receiver Transmitter (EUSART) Module:
 - Supports LIN 2.1 and J2602
 - Auto-Baud Detect
 - Auto Wake-up on BREAK character
- mTouch™ Sensing Oscillator Module:
 - Up to 12 input channels
- Data Signal Modulator Module:
 - Selectable modulator and carrier sources
- SR Latch:
 - Multiple Set/Reset input options
 - Emulates 555 Timer applications
- On-board Voltage Regulator:
 - Output voltage of 5.0V with tolerances of $\pm 2\%$ over temperature range
 - Maximum continuous input voltage of 30V
 - Internal thermal overload protection
 - Internal short circuit current limit
 - External components limited to filter capacitor only and load capacitor
 - Automatic thermal shutdown
- Internal Bus Transceiver compliant with LIN Bus Specifications 1.3, 2.0 and 2.1, and compliant to SAE J2602:
 - Support Baud Rates up to 20 Kbaud
 - 43V load dump protected
 - Very low EMI meets stringent OEM requirements
 - Wide supply voltage, 7.0V-30.0V continuous
 - Internal bus pull-up resistor and diode
 - Protected against ground shorts
 - Protected against loss of ground
 - High current drive
 - Automatic thermal shutdown
- Extended Temperature Range: -40 to +125°C

PIC16F1829LIN Device Overview

Device	Program Memory	Data Memory		I/Os ⁽¹⁾	10-bit ADC (ch)	Cap Sense (ch)	Comparators	Timers (8/16-bit)	EUSART ⁽²⁾	ECCP (Full-Bridge)	ECCP (Half-Bridge)	CCP	SR Latch	Other Features
	Words	SRAM (bytes)	Data EEPROM (bytes)											
PIC16F1829LIN	8K	1024	256	13	9	12	2	4/1	1	1	1	1 ⁽³⁾	Yes	LIN/J2602 Transceiver, Voltage Regulator

- Note 1:** One pin is input-only.
Note 2: EUSART dedicated to LIN communications.
Note 3: One CCP only available internally.

FIGURE 1: 20-PIN DIAGRAM FOR PIC16F1829LIN

SSOP

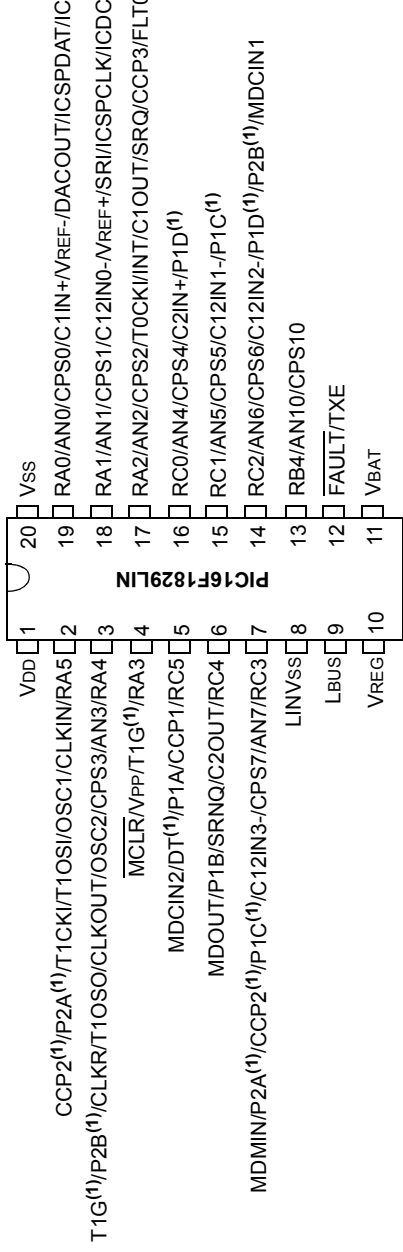

Note 1: Pin function is selectable via the APFCON0 or APFCON1 register.

PIC16F1829LIN

TABLE 1-1: PIC16F1829LIN PIN SUMMARY

I/O	20-Pin SSOP	A/D	Reference	Cap Sense	Comparator	SR Latch	Timers	CCP	EUSART	Interrupt	Modulator	Pull-up	Basic
RA0	19	AN0	VREF-DACOUT	CPS0	C1IN+	—	—	—	—	IOC	—	Y	ICSPDAT/ ICDDAT
RA1	18	AN1	VREF+	CPS1	C12IN0-	SRI	—	—	—	IOC	—	Y	ICSPCLK/ ICDCLK
RA2	17	AN2	—	CPS2	C1OUT	SRQ	T0CKI	CCP3 FLT0	—	INT/ IOC	—	Y	—
RA3	4	—	—	—	—	—	T1G ⁽¹⁾	—	—	IOC	—	Y ⁽⁴⁾	MCLR VPP
RA4	3	AN3	—	CPS3	—	—	T1G ⁽¹⁾ T1OSO	P2B ⁽¹⁾	—	IOC	—	Y	OSC2 CLKOUT CLKR
RA5	2	—	—	—	—	—	T1CKI T1OSI	CCP2 ⁽¹⁾ P2A ⁽¹⁾	—	IOC	—	Y	OSC1 CLKIN
RB4	13	AN10	—	CPS10	—	—	—	—	—	IOC	—	Y	—
RB5	⁽²⁾	—	—	—	—	—	—	—	RX ⁽¹⁾	—	—	Y	—
RB6	⁽²⁾	—	—	—	—	—	—	—	—	—	—	Y	CS/LWAKE
RB7	⁽²⁾	—	—	—	—	—	—	—	TX ⁽¹⁾	—	—	Y	—
RC0	16	AN4	—	CPS4	C2IN+	—	—	P1D ⁽¹⁾	—	—	—	Y	—
RC1	15	AN5	—	CPS5	C12IN1-	—	—	P1C ⁽¹⁾	—	—	—	Y	—
RC2	14	AN6	—	CPS6	C12IN2-	—	—	P1D ⁽¹⁾ P2B ⁽¹⁾	—	—	MDCIN1	Y	—
RC3	7	AN7	—	CPS7	C12IN3-	—	—	P1C ⁽¹⁾ CCP2 ⁽¹⁾ P2A ⁽¹⁾	—	—	MDMIN	Y	—
RC4	6	—	—	—	C2OUT	SRNQ	—	P1B	—	—	MDOUT	Y	—
RC5	5	—	—	—	—	—	—	CCP1 P1A	—	—	MDCIN2	Y	—
RC6	—	—	—	—	—	—	—	—	—	—	—	—	No connection
RC7	⁽²⁾	—	—	—	—	—	—	—	—	—	—	Y	POWERGOOD input from Voltage Regulator
FAULT /TXE	12	—	—	—	—	—	—	—	—	—	—	—	—
VBAT	11	—	—	—	—	—	—	—	—	—	—	—	—
VREG	10	—	—	—	—	—	—	—	—	—	—	—	—
LBUS	9	—	—	—	—	—	—	—	—	—	—	—	—
VDD	1	—	—	—	—	—	—	—	—	—	—	—	VDD
VSS	20	—	—	—	—	—	—	—	—	—	—	—	VSS
VSS	8	—	—	—	—	—	—	—	—	—	—	—	LIN VSS

Note 1: Pin function is selectable via the APFCON0 or APFCON1 register.
 2: Internal connection. No associated external pin.

Table of Contents

1.0 Device Overview	7
2.0 Using the PIC16F1829LIN in LIN Bus Applications	13
3.0 Enhanced Mid-range CPU	19
4.0 Memory Organization.....	21
5.0 I/O Ports	38
6.0 Analog-to-Digital Converter (ADC) Module.....	48
7.0 Master Synchronous Serial Port (MSSP1 and MSSP2) Module	51
8.0 Enhanced Universal Synchronous Asynchronous Receiver Transmitter (EUSART)	52
9.0 Consideration of Split Power Supplies and During Debug	57
10.0 Electrical Specifications	58
11.0 Packaging Information	64
Appendix A: Data Sheet Revision History	67
The Microchip Web Site	70
Customer Change Notification Service	70
Customer Support	70
Reader Response	71
Product Identification System	72

TO OUR VALUED CUSTOMERS

It is our intention to provide our valued customers with the best documentation possible to ensure successful use of your Microchip products. To this end, we will continue to improve our publications to better suit your needs. Our publications will be refined and enhanced as new volumes and updates are introduced.

If you have any questions or comments regarding this publication, please contact the Marketing Communications Department via E-mail at docerrors@microchip.com or fax the **Reader Response Form** in the back of this data sheet to (480) 792-4150. We welcome your feedback.

Most Current Data Sheet

To obtain the most up-to-date version of this data sheet, please register at our Worldwide Web site at:

<http://www.microchip.com>

You can determine the version of a data sheet by examining its literature number found on the bottom outside corner of any page. The last character of the literature number is the version number, (e.g., DS30000A is version A of document DS30000).

Errata

An errata sheet, describing minor operational differences from the data sheet and recommended workarounds, may exist for current devices. As device/documentation issues become known to us, we will publish an errata sheet. The errata will specify the revision of silicon and revision of document to which it applies.

To determine if an errata sheet exists for a particular device, please check with one of the following:

- Microchip's Worldwide Web site; <http://www.microchip.com>
- Your local Microchip sales office (see last page)

When contacting a sales office, please specify which device, revision of silicon and data sheet (include literature number) you are using.

Customer Notification System

Register on our web site at www.microchip.com to receive the most current information on all of our products.

PIC16F1829LIN

NOTES:

1.0 DEVICE OVERVIEW

The PIC16F1829LIN is described within this data sheet. It is available in 20-pin SSOP package. [Figure 1-1](#) shows a block diagram of the PIC16F1829LIN device. [Tables 1-1](#) and [1-2](#) show the pinout description.

Refer to [Table 1-1](#) for peripherals available per device.

TABLE 1-1: DEVICE PERIPHERAL SUMMARY

Peripheral		PIC16F1829LIN
ADC		•
Capacitive Sensing (CPS) Module		•
Data EEPROM		•
Digital-to-Analog Converter (DAC)		•
Digital Signal Modulator (DSM)		•
EUSART		•
Fixed Voltage Reference (FVR)		•
SR Latch		•
Capture/Compare/PWM Modules		
	ECCP1	•
	ECCP2	•
	CCP3	•
Comparators		
	C1	•
	C2	•
Timers		
	Timer0	•
	Timer1	•
	Timer2	•
	Timer4	•
	Timer6	•

PIC16F1829LIN

FIGURE 1-1: PIC16F1829LIN BLOCK DIAGRAM⁽¹⁾

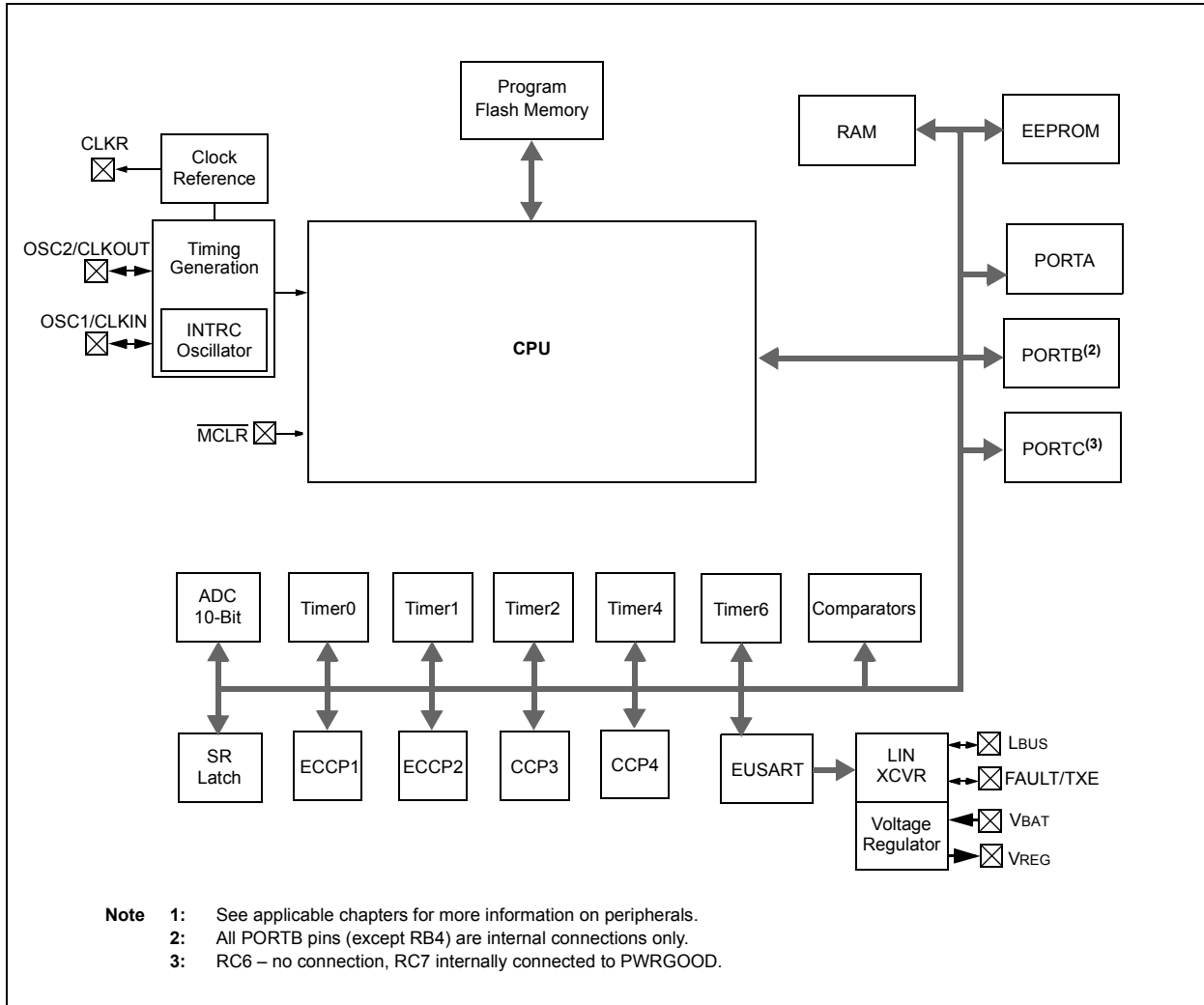

TABLE 1-2: PIC16F1829LIN PINOUT DESCRIPTION

Name	Function	Input Type	Output Type	Description
RA0/AN0/CPS0/C1IN+/VREF-/DACOUT/ICSPDAT/ICDDAT	RA0	TTL	CMOS	General purpose I/O.
	AN0	AN	—	A/D Channel 0 input.
	CPS0	AN	—	Capacitive sensing input 0.
	C1IN+	AN	—	Comparator C1 positive input.
	VREF-	AN	—	A/D and DAC Negative Voltage Reference input.
	DACOUT	—	AN	Digital-to-Analog Converter output.
	ICSPDAT	ST	CMOS	ICSP™ Data I/O.
	ICDDAT	ST	CMOS	In-Circuit Data I/O.
RA1/AN1/CPS1/C12IN0-/VREF+/SRI/ICSPCLK/ICDCLK	RA1	TTL	CMOS	General purpose I/O.
	AN1	AN	—	A/D Channel 1 input.
	CPS1	AN	—	Capacitive sensing input 1.
	C12IN0-	AN	—	Comparator C1 or C2 negative input.
	VREF+	AN	—	A/D and DAC Positive Voltage Reference input.
	SRI	ST	—	SR latch input.
	ICSPCLK	ST	—	Serial Programming Clock.
	ICDCLK	ST	—	In-Circuit Debug Clock.
RA2/AN2/CPS2/T0CKI/INT/C1OUT/SRQ/CCP3/FLT0	RA2	ST	CMOS	General purpose I/O.
	AN2	AN	—	A/D Channel 2 input.
	CPS2	AN	—	Capacitive sensing input 2.
	T0CKI	ST	—	Timer0 clock input.
	INT	ST	—	External interrupt.
	C1OUT	—	CMOS	Comparator C1 output.
	SRQ	—	CMOS	SR latch non-inverting output.
	CCP3	ST	CMOS	Capture/Compare/PWM 3.
RA3/T1G ⁽¹⁾ /VPP/MCLR	RA3	TTL	—	General purpose input.
	T1G	ST	—	Timer1 gate input.
	VPP	HV	—	Programming voltage.
	MCLR	ST	—	Master Clear with internal pull-up.
RA4/AN3/CPS3/OSC2/CLKOUT/T1OSO/CLKR/P2B ⁽¹⁾ /T1G ^(1,2)	RA4	TTL	CMOS	General purpose I/O.
	AN3	AN	—	A/D Channel 3 input.
	CPS3	AN	—	Capacitive sensing input 3.
	OSC2	—	CMOS	Comparator C2 output.
	CLKOUT	—	CMOS	Fosc/4 output.
	T1OSO	XTAL	XTAL	Timer1 oscillator connection.
	CLKR	—	CMOS	Clock Reference output.
	P2B	—	CMOS	PWM output.
T1G	ST	—	Timer1 gate input.	

Legend: AN = Analog input or output CMOS = CMOS compatible input or output OD = Open Drain
TTL = TTL compatible input ST = Schmitt Trigger input with CMOS levels I²C™ = Schmitt Trigger input with I²C levels
HV = High Voltage XTAL = Crystal

Note 1: Pin functions can be moved using the APFCON0 or APFCON1 register.
2: Default function location.
3: Internal Connection. No associated external pin.

PIC16F1829LIN

TABLE 1-2: PIC16F1829LIN PINOUT DESCRIPTION (CONTINUED)

Name	Function	Input Type	Output Type	Description
RA5/CLKIN/OSC1/T1OSI/ T1CKI/P2A ^(1,2) /CCP2 ⁽¹⁾	RA5	TTL	CMOS	General purpose I/O.
	CLKIN	CMOS	—	External clock input (EC mode).
	OSC1	XTAL	—	Crystal/Resonator (LP, XT, HS modes).
	T1OSI	XTAL	XTAL	Timer1 oscillator connection.
	T1CKI	ST	—	Timer1 clock input.
	P2A	—	CMOS	PWM output.
RB4/AN10/CPS10	RB4	TTL	CMOS	General purpose I/O.
	AN10	AN	—	A/D Channel 10 input.
	CPS10	AN	—	Capacitive sensing input 10.
RB5 ⁽³⁾ /RX ^(1,2)	RB5	TTL	CMOS	General purpose I/O.
	RX	ST	—	USART asynchronous input.
RB6 ⁽³⁾ /CS/LWAKE	RB6	TTL	CMOS	General purpose I/O.
	CS/ LWAKE	TTL	OD	LIN Transceiver Chip Select and Wake-up.
RB7 ⁽³⁾ /TX ^(1,2)	RB7	TTL	CMOS	General purpose I/O.
	TX	—	CMOS	USART asynchronous transmit.
RC0/AN4/CPS4/C2IN+/P1D ⁽¹⁾	RC0	TTL	CMOS	General purpose I/O.
	AN4	AN	—	A/D Channel 4 input.
	CPS4	AN	—	Capacitive sensing input 4.
	C2IN+	AN	—	Comparator C2 positive input.
	P1D	—	CMOS	PWM output.
RC1/AN5/CPS5/C12IN1-/P1C ⁽¹⁾	RC1	TTL	CMOS	General purpose I/O.
	AN5	AN	—	A/D Channel 5 input.
	CPS5	AN	—	Capacitive sensing input 5.
	C12IN1-	AN	—	Comparator C1 or C2 negative input.
	P1C	—	CMOS	PWM output.
RC2/AN6/CPS6/C12IN2-/ P1D ^(1,2) /P2B ^(1,2) /MDCIN1	RC2	TTL	CMOS	General purpose I/O.
	AN6	AN	—	A/D Channel 6 input.
	CPS6	AN	—	Capacitive sensing input 6.
	C12IN2-	AN	—	Comparator C1 or C2 negative input.
	P1D	—	CMOS	PWM output.
	P2B	—	CMOS	PWM output.
RC3/AN7/CPS7/C12IN3-/ P2A ^(1,2) /CCP2 ^(1,2) /P1C ^(1,2) / MDMIN	RC3	TTL	CMOS	General purpose I/O.
	AN7	AN	—	A/D Channel 7 input.
	CPS7	AN	—	Capacitive sensing input 7.
	C12IN3-	AN	—	Comparator C1 or C2 negative input.
	P2A	—	CMOS	PWM output.
	CCP2	AN	—	Capacitive sensing input 2.
	P1C	—	CMOS	PWM output.
	MDMIN	ST	—	Modulator source input.

Legend: AN = Analog input or output CMOS = CMOS compatible input or output OD = Open Drain
TTL = TTL compatible input ST = Schmitt Trigger input with CMOS levels I²C™ = Schmitt Trigger input with I²C levels
HV = High Voltage XTAL = Crystal

- Note 1:** Pin functions can be moved using the APFCON0 or APFCON1 register.
2: Default function location.
3: Internal Connection. No associated external pin.

TABLE 1-2: PIC16F1829LIN PINOUT DESCRIPTION (CONTINUED)

Name	Function	Input Type	Output Type	Description
RC4/C2OUT/SRNQ/P1B/ MDOUT	RC4	TTL	CMOS	General purpose I/O.
	C2OUT	—	CMOS	Comparator C2 output.
	SRNQ	—	CMOS	SR latch inverting output.
	P1B	—	CMOS	PWM output.
	MDOUT	—	CMOS	Modulator output.
RC5/P1A/CCP1// MDCIN2	RC5	TTL	CMOS	General purpose I/O.
	P1A	—	CMOS	PWM output.
	CCP1	ST	CMOS	Capture/Compare/PWM 1.
	MDCIN2	ST	—	Modulator Carrier Input 2.
RC6	RC6	—	—	No connection.
RC7/POWERGOOD	RC7	TTL	—	POWERGOOD input from voltage regulator.
FAULT/TXE	—	TTL	OD	LIN Fault Indicator and Transmitter Enable.
VBAT	Battery Supply	Power	—	Battery voltage input to the LIN Transceiver and the voltage regulator.
VREG	Regulator Output	—	Power	Regulated 5.0V output.
LBUS	Network Bus	HV	HV	LIN/J2602 bus network connection.
VDD	VDD	Power	—	Positive supply.
VSS	VSS	Power	—	Ground reference.
LIN VSS	VSS	Power	—	Ground reference for voltage regulator and LIN bus.

Legend: AN = Analog input or output CMOS = CMOS compatible input or output OD = Open Drain
TTL = TTL compatible input ST = Schmitt Trigger input with CMOS levels I²C™ = Schmitt Trigger input with I²C levels
HV = High Voltage XTAL = Crystal

- Note 1:** Pin functions can be moved using the APFCON0 or APFCON1 register.
2: Default function location.
3: Internal Connection. No associated external pin.

PIC16F1829LIN

NOTES:

2.0 USING THE PIC16F1829LIN IN LIN BUS APPLICATIONS

Note: Failure to follow the recommended setup and initialization may result in improper or unknown LIN operation.

2.1 Hardware

The PIC16F1829LIN internal connections are optimized to reduce the number of components in a typical LIN/J2602 node in a LIN bus system. Some features and modules of the stand-alone PIC16F1829 are no longer available or their functionality has changed.

FIGURE 2-1: TYPICAL LIN NETWORK CONFIGURATION

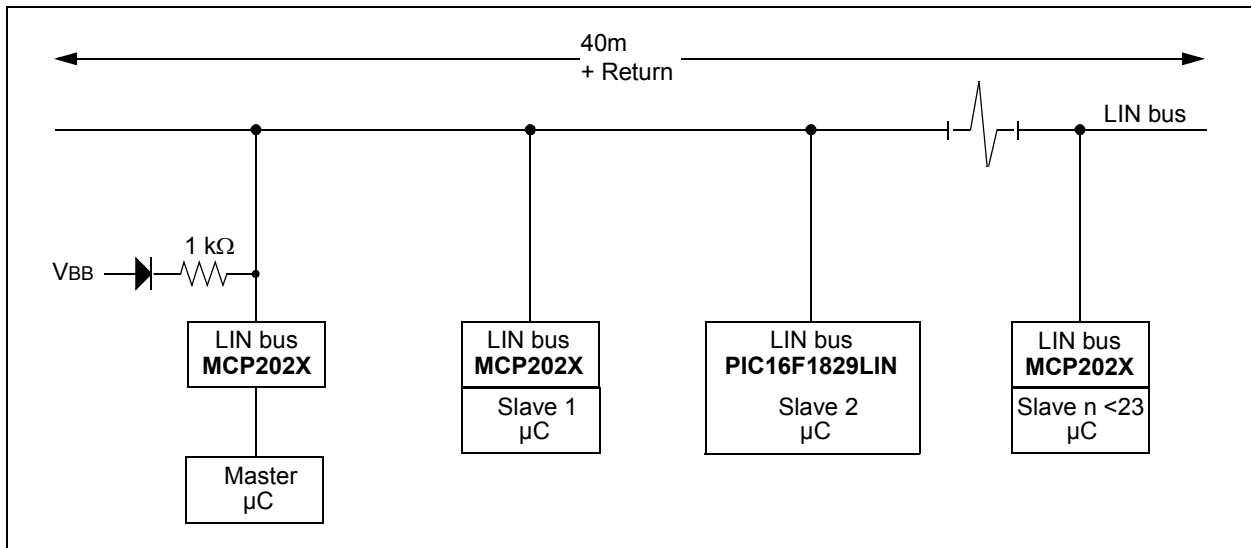

For this reason, the following figure (Figure 2-2) is a recommended block diagram. Note that the microcontroller is powered by the internal voltage regulator and an external connection must be made between VREG and VBB along with a load capacitor. FAULT/TXE can be monitored or controlled by any I/O pin.

PIC16F1829LIN

FIGURE 2-2: TYPICAL PIC16F1829LIN APPLICATION

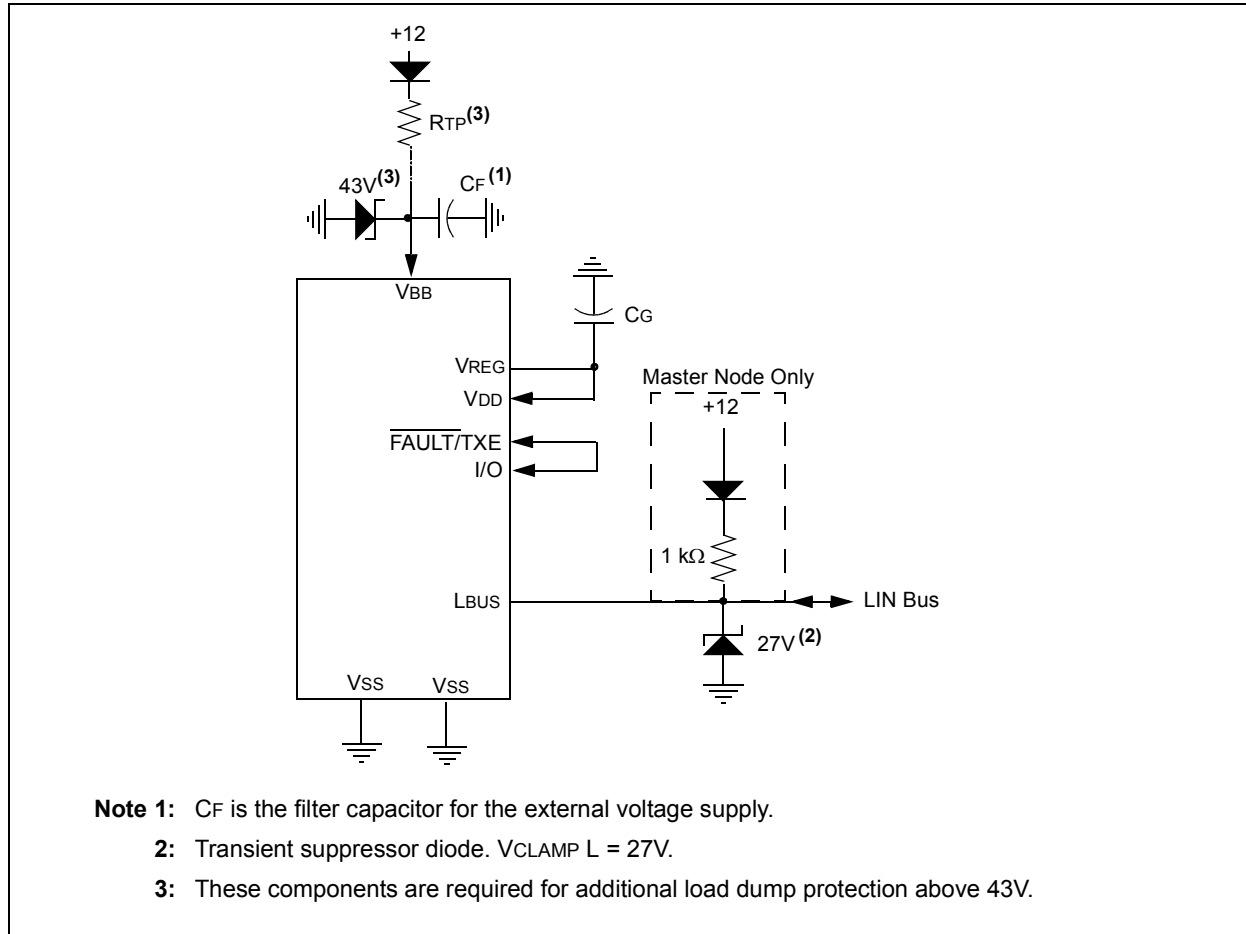

2.2 Software

Please refer to the sections of this data sheet to determine what facilities have changed and what register values need to be properly initialized. Failure to follow these guidelines may result in improper operation.

2.2.1 TYPICAL INITIALIZATION CODE

```
InitialiseIOports
    banksel ANSELH
    MOVLW 0x04          ;disable AN8:9,11
    ANDWF ANSELH,f
    banksel TRISB
    MOVLW 0xC0          ;PORTB7:6 must be inputs
    IORWF TRISB,f
    MOVLW 0xCF          ;PORTB5:4 must be outputs
    ANDWF TRISB,f
    MOVLW 0x80
    IORWF TRISC,f      ;PORTC7 is an input
    banksel LATB
    BSF LINCS          ;Chip Select Transceiver
    RETURN

SetupLINUSART
    banksel RCSTA
    MOVLW B'10010000'  ;UART enabled,8-bit,continuous receive
    MOVWF RCSTA
    MOVLW B'00000100'  ;8-bit, asynchronous, high-baudrate
    MOVWF TXSTA
    MOVLW B'00001000'  ;16-bit Baud Rate Generator
    MOVWF BAUDCON
    CLRF SPBRGH
    MOVLW 0x31          ;setup initially for 20KBaud @ 4.0MHz, BRGH=1, BRG16=1
    MOVWF SPBRG
    banksel LATB
    BSF LINCS          ;to enable transceiver
    RETURN
```

2.2.2 SAMPLE TRANSMIT SOFTWARE

This routine is called when PIR1<TXIF> = 1:

```
PutDATAbyte
    banksel TXREG
    MOVF INDF0,w        ; copy data byte into w-register
    MOVWF TXREG
    INCF FSR0, f        ; point to next location
    DECFSZ MESSAGE_COUNTER, f ; decrement Message Counter by one
    RETURN
```

PIC16F1829LIN

2.2.3 SAMPLE RECEIVE SOFTWARE

The following routines are called when $PIR1<RCIF> = 1$:

```
GetBREAK
    banksel RCSTA
    BTFSS RCSTA,FERR      ; was BREAK character longer than 8 bits?
    GOTO  BadBREAKchar   ; no, not a valid BREAK, too short
    MOVF  RCREG,w        ; dump break character, reset RCIF and FERR
    BTFSS STATUS,Z
    GOTO  BadBREAKchar   ; no, not a valid BREAK, not zero
    DECF  MESSAGE_COUNTER
    banksel PORTB
    BTFSS LINRX
    GOTO  $-2
    banksel BAUDCTL
    BSF   BAUDCTL,ABDEN  ; enable AutoBaud
    RETURN

BadBREAKchar
    MOVF  RCREG,w        ; dump break character, reset RCIF and FERR
    RETURN

GetSYNC
    banksel BAUDCTL
    BTFSC BAUDCTL,ABDOVF; did baud rate generator overflow?
    GOTO  BadSYNCchar; yes, bad sync character
    BTFSC RCSTA,FERR; was there a Framing Error?
    GOTO  BadSYNCchar; yes, bad sync character
    DECF  SPBRG
    MOVF  RCREG,w        ; dump sync character, reset RCIF
    DECF  MESSAGE_COUNTER
    RETURN

BadSYNCchar
    BCF   BAUDCTL,ABDOVF; clear the overflow condition
    MOVLW .12           ; reset the state machine
    MOVWF MESSAGE_COUNTER
    RETURN

GetDATAbyte
    banksel RCREG
    MOVF  RCREG,w        ; get character, reset RCIF and FERR
    MOVWF RXTX_REG      ; copy data into w-register
    MOVWF INDF0         ; copy data into data area
    INCF  FSR0, f       ; point to next location
    DECF  MESSAGE_COUNTER, f ; decrement number of bytes to receive by one
    RETURN
```

2.3 Routing CCP4 to a Pin

Normally, CCP4 uses RC6 as an output pin. This pin is not available on the PIC16F1829LIN. This output function can be re-routed to RC4, through the Data Signal Modulator (DSM), as shown below.

```
; Setup CCP4
banksel PR2
movlw 0xFF          ; set PWM for highest resolution
movwf PR2
banksel CCP4CON
movlw b'00001100'; set for PWM mode
movwf CCP4CON
movlw 0x80          ; preload the duty cycle with a value
movwf CCPR4L
banksel CCPTMRS
movlw 0x00          ; set Timer2 as clock source
movwf CCPTMRS
banksel PIR1
bcf   PIR1,TMR2IF; clear timer overflow flag
movlw b'00000101'; clock prescaler = 4
movwf T2CON
bsf   T2CON,TMR2ON; turn on Timer 2
; Setup DSM to route CCP4 to RC4
banksel MDCON
movlw b'11000000'; enable DSM, enable output pin
movwf MDCON
movlw 0x00          ; modulation controlled by MCBIT
movwf MDSRC
movlw 0x87          ; select CCP4 as carrier frequency and disable RC6
movwf MDCARL
movwf MDCARH        ; modulation source does not matter because high and low carriers are the
                    ; same.
```

PIC16F1829LIN

NOTES:

3.0 ENHANCED MID-RANGE CPU

See "PIC16(L)F1825/1829 Data Sheet" (DS41440) for description of the enhanced mid-range 8-bit CPU core.

FIGURE 3-1: CORE BLOCK DIAGRAM

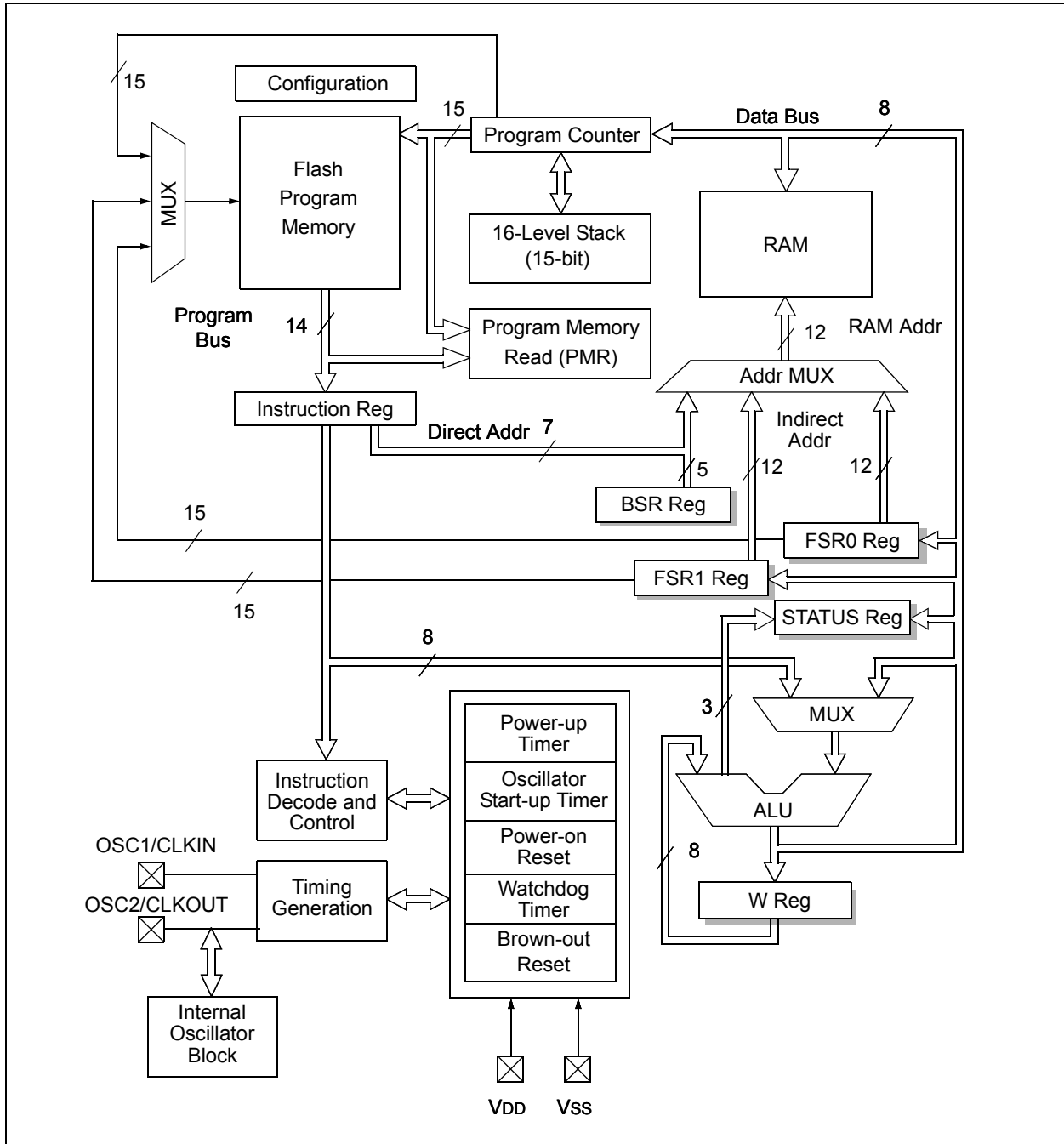

PIC16F1829LIN

NOTES:

4.0 MEMORY ORGANIZATION

See “*PIC16(L)F1825/1829 Data Sheet*” (DS41440) for descriptions of Program memory, Data RAM and Data EEPROM.

TABLE 4-1: PIC16F1829LIN MEMORY MAP, BANKS 0-7

BANK 0		BANK 1		BANK 2		BANK 3		BANK 4		BANK 5		BANK	
000h	INDF0	100h	INDF0	180h	INDF0	200h	INDF0	280h	INDF0	300h	INDF0	300h	INDF0
001h	INDF1	101h	INDF1	181h	INDF1	201h	INDF1	281h	INDF1	301h	INDF1	301h	INDF1
002h	PCL	102h	PCL	182h	PCL	202h	PCL	282h	PCL	302h	PCL	302h	PCL
003h	STATUS	103h	STATUS	183h	STATUS	203h	STATUS	283h	STATUS	303h	STATUS	303h	STATUS
004h	FSR0L	104h	FSR0L	184h	FSR0L	204h	FSR0L	284h	FSR0L	304h	FSR0L	304h	FSR0L
005h	FSR0H	105h	FSR0H	185h	FSR0H	205h	FSR0H	285h	FSR0H	305h	FSR0H	305h	FSR0H
006h	FSR1L	106h	FSR1L	186h	FSR1L	206h	FSR1L	286h	FSR1L	306h	FSR1L	306h	FSR1L
007h	FSR1H	107h	FSR1H	187h	FSR1H	207h	FSR1H	287h	FSR1H	307h	FSR1H	307h	FSR1H
008h	BSR	108h	BSR	188h	BSR	208h	BSR	288h	BSR	308h	BSR	308h	BSR
009h	WREG	109h	WREG	189h	WREG	209h	WREG	289h	WREG	309h	WREG	309h	WREG
00Ah	PCLATH	10Ah	PCLATH	18Ah	PCLATH	20Ah	PCLATH	28Ah	PCLATH	30Ah	PCLATH	30Ah	PCLATH
00Bh	INTCON	10Bh	INTCON	18Bh	INTCON	20Bh	INTCON	28Bh	INTCON	30Bh	INTCON	30Bh	INTCON
00Ch	PORTA	10Ch	TRISA	18Ch	ANSELA	20Ch	WPUA	28Ch	—	30Ch	—	30Ch	—
00Dh	PORTB	10Dh	TRISB	18Dh	ANSELB	20Dh	WPUB	28Dh	—	30Dh	—	30Dh	—
00Eh	PORTC	10Eh	TRISC	18Eh	ANSELC	20Eh	WPUC	28Eh	—	30Eh	—	30Eh	—
00Fh	—	10Fh	—	18Fh	—	20Fh	—	28Fh	—	30Fh	—	30Fh	—
010h	—	110h	—	190h	—	210h	—	290h	—	310h	—	310h	—
011h	PIR1	111h	PIE1	191h	EEDR1	211h	SSP1BUF	291h	CCPR1L	311h	CCPR3L	311h	CCPR3L
012h	PIR2	112h	PIE2	192h	EEDR2	212h	SSP1ADD	292h	CCPR1H	312h	CCPR3H	312h	CCPR3H
013h	—	113h	—	193h	EEDATL	213h	SSP1MSK	293h	CCP1CON	313h	CCP3CON	313h	CCP3CON
014h	—	114h	—	194h	EEDATH	214h	SSP1STAT	294h	PWM1CON	314h	—	314h	—
015h	TMR0	115h	OPTION_REG	195h	ECON1	215h	SSP1CON2	295h	CCPIAS	315h	—	315h	—
016h	TMR1L	116h	PCON	196h	ECON2	216h	SSP1CON2	296h	PSTR1CON	316h	—	316h	—
017h	TMR1H	117h	WDTCON	197h	—	217h	SSP1CON3	297h	—	317h	—	317h	—
018h	T1CON	118h	OSCTUNE	198h	—	218h	—	298h	CCPR2L	318h	—	318h	—
019h	T1GCON	119h	OSCCON	199h	RCREG	219h	SSP2BUF	299h	CCPR2H	319h	—	319h	—
01Ah	TMR2	11Ah	OSCSSTAT	19Ah	TXREG	21Ah	SSP2ADD	29Ah	CCP2CON	31Ah	—	31Ah	—
01Bh	PR2	11Bh	ADRESL	19Bh	SPBRGL	21Bh	SSP2MSK	29Bh	PWM2CON	31Bh	—	31Bh	—
01Ch	T2CON	11Ch	ADRESH	19Ch	SPBRGH	21Ch	SSP2STAT	29Ch	CCP2AS	31Ch	—	31Ch	—
01Dh	—	11Dh	ADCON0	19Dh	RCSTA	21Dh	SSP2CON2	29Dh	PSTR2CON	31Dh	—	31Dh	—
01Eh	CPSCON0	11Eh	ADCON1	19Eh	TXSTA	21Eh	SSP2CON2	29Eh	CCPTMRS	31Eh	—	31Eh	—
01Fh	CPSCON1	11Fh	—	19Fh	BAUDCON	21Fh	SSP2CON3	29Fh	—	31Fh	—	31Fh	—
020h	General Purpose Register 96 Bytes	120h	General Purpose Register 80 Bytes	1A0h	General Purpose Register 80 Bytes	220h	General Purpose Register 80 Bytes	2A0h	General Purpose Register 80 Bytes	320h	General Purpose Register 80 Bytes	320h	General Purpose Register 80 Bytes
06Fh	—	16Fh	—	1EFh	—	26Fh	—	2EFh	—	36Fh	—	36Fh	—
070h	—	170h	—	1F0h	—	270h	—	2F0h	—	370h	—	370h	—
07Fh	—	17Fh	—	1FFh	—	27Fh	—	2FFh	—	37Fh	—	37Fh	—

Legend: ■ = Unimplemented data memory locations, read as '0'

Note 1: Registers in bold have functional differences. Please refer to the appropriate chapters for details.

TABLE 4-2: PIC16F1829LIN MEMORY MAP, BANKS 8-15

BANK 8		BANK 9		BANK 10		BANK 11		BANK 12		BANK 13		BANK 14	
400h	INDF0	480h	INDF0	500h	INDF0	580h	INDF0	600h	INDF0	680h	INDF0	700h	INDF0
401h	INDF1	481h	INDF1	501h	INDF1	581h	INDF1	601h	INDF1	681h	INDF1	701h	INDF1
402h	PCL	482h	PCL	502h	PCL	582h	PCL	602h	PCL	682h	PCL	702h	PCL
403h	STATUS	483h	STATUS	503h	STATUS	583h	STATUS	603h	STATUS	683h	STATUS	703h	STATUS
404h	FSR0L	484h	FSR0L	504h	FSR0L	584h	FSR0L	604h	FSR0L	684h	FSR0L	704h	FSR0L
405h	FSR0H	485h	FSR0H	505h	FSR0H	585h	FSR0H	605h	FSR0H	685h	FSR0H	705h	FSR0H
406h	FSR1L	486h	FSR1L	506h	FSR1L	586h	FSR1L	606h	FSR1L	686h	FSR1L	706h	FSR1L
407h	FSR1H	487h	FSR1H	507h	FSR1H	587h	FSR1H	607h	FSR1H	687h	FSR1H	707h	FSR1H
408h	BSR	488h	BSR	508h	BSR	588h	BSR	608h	BSR	688h	BSR	708h	BSR
409h	WREG	489h	WREG	509h	WREG	589h	WREG	609h	WREG	689h	WREG	709h	WREG
40Ah	PCLATH	48Ah	PCLATH	50Ah	PCLATH	58Ah	PCLATH	60Ah	PCLATH	68Ah	PCLATH	70Ah	PCLATH
40Bh	INTCON	48Bh	INTCON	50Bh	INTCON	58Bh	INTCON	60Bh	INTCON	68Bh	INTCON	70Bh	INTCON
40Ch	—	48Ch	—	50Ch	—	58Ch	—	60Ch	—	68Ch	—	70Ch	—
40Dh	—	48Dh	—	50Dh	—	58Dh	—	60Dh	—	68Dh	—	70Dh	—
40Eh	—	48Eh	—	50Eh	—	58Eh	—	60Eh	—	68Eh	—	70Eh	—
40Fh	—	48Fh	—	50Fh	—	58Fh	—	60Fh	—	68Fh	—	70Fh	—
410h	—	490h	—	510h	—	590h	—	610h	—	690h	—	710h	—
411h	—	491h	—	511h	—	591h	—	611h	—	691h	—	711h	—
412h	—	492h	—	512h	—	592h	—	612h	—	692h	—	712h	—
413h	—	493h	—	513h	—	593h	—	613h	—	693h	—	713h	—
414h	—	494h	—	514h	—	594h	—	614h	—	694h	—	714h	—
415h	TMR4	495h	—	515h	—	595h	—	615h	—	695h	—	715h	—
416h	PR4	496h	—	516h	—	596h	—	616h	—	696h	—	716h	—
417h	T4CON	497h	—	517h	—	597h	—	617h	—	697h	—	717h	—
418h	—	498h	—	518h	—	598h	—	618h	—	698h	—	718h	—
419h	—	499h	—	519h	—	599h	—	619h	—	699h	—	719h	—
41Ah	—	49Ah	—	51Ah	—	59Ah	—	61Ah	—	69Ah	—	71Ah	—
41Bh	—	49Bh	—	51Bh	—	59Bh	—	61Bh	—	69Bh	—	71Bh	—
41Ch	TMR6	49Ch	—	51Ch	—	59Ch	—	61Ch	—	69Ch	—	71Ch	—
41Dh	PR6	49Dh	—	51Dh	—	59Dh	—	61Dh	—	69Dh	—	71Dh	—
41Eh	T6CON	49Eh	—	51Eh	—	59Eh	—	61Eh	—	69Eh	—	71Eh	—
41Fh	—	49Fh	—	51Fh	—	59Fh	—	61Fh	—	69Fh	—	71Fh	—
420h	General Purpose Register 80 Bytes	4A0h	General Purpose Register 80 Bytes	520h	General Purpose Register 80 Bytes	5A0h	General Purpose Register 80 Bytes	620h	General Purpose Register 48 Bytes	6A0h	Unimplemented Read as '0'	720h	Unimplemented Read as '0'
46Fh	Accesses 70h – 7Fh	4EFh	Accesses 70h – 7Fh	56Fh	Accesses 70h – 7Fh	5EFh	Accesses 70h – 7Fh	66Fh	Accesses 70h – 7Fh	6EFh	Accesses 70h – 7Fh	76Fh	Accesses 70h – 7Fh
470h	—	4F0h	—	570h	—	5F0h	—	670h	—	6F0h	—	770h	—
47Fh	—	4Fh	—	57Fh	—	5Fh	—	67Fh	—	6Fh	—	77Fh	—

Legend: ■ = Unimplemented data memory locations, read as '0'

Note 1: Registers in bold have functional differences. Please refer to the appropriate chapters for details.

TABLE 4-3: PIC16F1829LIN MEMORY MAP, BANKS 16-23

BANK 16			BANK 17			BANK 18			BANK 19			BANK 20			BANK 21			BANK 22		
800h	INDF0	880h	INDF0	900h	INDF0	980h	INDF0	A00h	INDF0	A80h	INDF0	A00h	INDF0	A80h	INDF0	B00h	INDF0	B00h	INDF0	B00h
801h	INDF1	881h	INDF1	901h	INDF1	981h	INDF1	A01h	INDF1	A81h	INDF1	A01h	INDF1	A81h	INDF1	B01h	INDF1	B01h	INDF1	B01h
802h	PCL	882h	PCL	902h	PCL	982h	PCL	A02h	PCL	A82h	PCL	A02h	PCL	A82h	PCL	B02h	PCL	B02h	PCL	B02h
803h	STATUS	883h	STATUS	903h	STATUS	983h	STATUS	A03h	STATUS	A83h	STATUS	A03h	STATUS	A83h	STATUS	B03h	STATUS	B03h	STATUS	B03h
804h	FSR0L	884h	FSR0L	904h	FSR0L	984h	FSR0L	A04h	FSR0L	A84h	FSR0L	A04h	FSR0L	A84h	FSR0L	B04h	FSR0L	B04h	FSR0L	B04h
805h	FSR0H	885h	FSR0H	905h	FSR0H	985h	FSR0H	A05h	FSR0H	A85h	FSR0H	A05h	FSR0H	A85h	FSR0H	B05h	FSR0H	B05h	FSR0H	B05h
806h	FSR1L	886h	FSR1L	906h	FSR1L	986h	FSR1L	A06h	FSR1L	A86h	FSR1L	A06h	FSR1L	A86h	FSR1L	B06h	FSR1L	B06h	FSR1L	B06h
807h	FSR1H	887h	FSR1H	907h	FSR1H	987h	FSR1H	A07h	FSR1H	A87h	FSR1H	A07h	FSR1H	A87h	FSR1H	B07h	FSR1H	B07h	FSR1H	B07h
808h	BSR	888h	BSR	908h	BSR	988h	BSR	A08h	BSR	A88h	BSR	A08h	BSR	A88h	BSR	B08h	BSR	B08h	BSR	B08h
809h	WREG	889h	WREG	909h	WREG	989h	WREG	A09h	WREG	A89h	WREG	A09h	WREG	A89h	WREG	B09h	WREG	B09h	WREG	B09h
80Ah	PCLATH	88Ah	PCLATH	90Ah	PCLATH	98Ah	PCLATH	A0Ah	PCLATH	A8Ah	PCLATH	A0Ah	PCLATH	A8Ah	PCLATH	B0Ah	PCLATH	B0Ah	PCLATH	B0Ah
80Bh	INTCON	88Bh	INTCON	90Bh	INTCON	98Bh	INTCON	A0Bh	INTCON	A8Bh	INTCON	A0Bh	INTCON	A8Bh	INTCON	B0Bh	INTCON	B0Bh	INTCON	B0Bh
80Ch	—	88Ch	—	90Ch	—	98Ch	—	A0Ch	—	A8Ch	—	A0Ch	—	A8Ch	—	B0Ch	—	B0Ch	—	B0Ch
80Dh	—	88Dh	—	90Dh	—	98Dh	—	A0Dh	—	A8Dh	—	A0Dh	—	A8Dh	—	B0Dh	—	B0Dh	—	B0Dh
80Eh	—	88Eh	—	90Eh	—	98Eh	—	A0Eh	—	A8Eh	—	A0Eh	—	A8Eh	—	B0Eh	—	B0Eh	—	B0Eh
80Fh	—	88Fh	—	90Fh	—	98Fh	—	A0Fh	—	A8Fh	—	A0Fh	—	A8Fh	—	B0Fh	—	B0Fh	—	B0Fh
810h	—	890h	—	910h	—	990h	—	A10h	—	A90h	—	A10h	—	A90h	—	B10h	—	B10h	—	B10h
811h	—	891h	—	911h	—	991h	—	A11h	—	A91h	—	A11h	—	A91h	—	B11h	—	B11h	—	B11h
812h	—	892h	—	912h	—	992h	—	A12h	—	A92h	—	A12h	—	A92h	—	B12h	—	B12h	—	B12h
813h	—	893h	—	913h	—	993h	—	A13h	—	A93h	—	A13h	—	A93h	—	B13h	—	B13h	—	B13h
814h	—	894h	—	914h	—	994h	—	A14h	—	A94h	—	A14h	—	A94h	—	B14h	—	B14h	—	B14h
815h	—	895h	—	915h	—	995h	—	A15h	—	A95h	—	A15h	—	A95h	—	B15h	—	B15h	—	B15h
816h	—	896h	—	916h	—	996h	—	A16h	—	A96h	—	A16h	—	A96h	—	B16h	—	B16h	—	B16h
817h	—	897h	—	917h	—	997h	—	A17h	—	A97h	—	A17h	—	A97h	—	B17h	—	B17h	—	B17h
818h	—	898h	—	918h	—	998h	—	A18h	—	A98h	—	A18h	—	A98h	—	B18h	—	B18h	—	B18h
819h	—	899h	—	919h	—	999h	—	A19h	—	A99h	—	A19h	—	A99h	—	B19h	—	B19h	—	B19h
81Ah	—	89Ah	—	91Ah	—	99Ah	—	A1Ah	—	A9Ah	—	A1Ah	—	A9Ah	—	B1Ah	—	B1Ah	—	B1Ah
81Bh	—	89Bh	—	91Bh	—	99Bh	—	A1Bh	—	A9Bh	—	A1Bh	—	A9Bh	—	B1Bh	—	B1Bh	—	B1Bh
81Ch	—	89Ch	—	91Ch	—	99Ch	—	A1Ch	—	A9Ch	—	A1Ch	—	A9Ch	—	B1Ch	—	B1Ch	—	B1Ch
81Dh	—	89Dh	—	91Dh	—	99Dh	—	A1Dh	—	A9Dh	—	A1Dh	—	A9Dh	—	B1Dh	—	B1Dh	—	B1Dh
81Eh	—	89Eh	—	91Eh	—	99Eh	—	A1Eh	—	A9Eh	—	A1Eh	—	A9Eh	—	B1Eh	—	B1Eh	—	B1Eh
81Fh	—	89Fh	—	91Fh	—	99Fh	—	A1Fh	—	A9Fh	—	A1Fh	—	A9Fh	—	B1Fh	—	B1Fh	—	B1Fh
820h	Unimplemented Read as '0'	8A0h	Unimplemented Read as '0'	920h	Unimplemented Read as '0'	9A0h	Unimplemented Read as '0'	A20h	Unimplemented Read as '0'	AA0h	Unimplemented Read as '0'	A20h	Unimplemented Read as '0'	AA0h	Unimplemented Read as '0'	B20h	Unimplemented Read as '0'	B20h	Unimplemented Read as '0'	B20h
86Fh	Accesses 70h – 7Fh	8EFh	Accesses 70h – 7Fh	96Fh	Accesses 70h – 7Fh	9EFh	Accesses 70h – 7Fh	A6Fh	Accesses 70h – 7Fh	AEFh	Accesses 70h – 7Fh	A6Fh	Accesses 70h – 7Fh	AEFh	Accesses 70h – 7Fh	B6Fh	Accesses 70h – 7Fh	B6Fh	Accesses 70h – 7Fh	B6Fh
870h	—	8F0h	—	970h	—	9F0h	—	A70h	—	AF0h	—	A70h	—	AF0h	—	B70h	—	B70h	—	B70h
87Fh	—	8FFh	—	97Fh	—	9FFh	—	A7Fh	—	AFh	—	A7Fh	—	AFh	—	B7Fh	—	B7Fh	—	B7Fh

Legend: ■ = Unimplemented data memory locations, read as '0'.

Note 1: Registers in bold have functional differences. Please refer to the appropriate chapters for details.

TABLE 4-4: PIC16F1829LIN MEMORY MAP, BANKS 24-31

BANK 24		BANK 25		BANK 26		BANK 27		BANK 28		BANK 29		BANK 30		BANK 31	
C00h	INDF0	C80h	INDF0	D00h	INDF0	D80h	INDF0	E00h	INDF0	E80h	INDF0	F00h	INDF0		
C01h	INDF1	C81h	INDF1	D01h	INDF1	D81h	INDF1	E01h	INDF1	E81h	INDF1	F01h	INDF1		
C02h	PCL	C82h	PCL	D02h	PCL	D82h	PCL	E02h	PCL	E82h	PCL	F02h	PCL		
C03h	STATUS	C83h	STATUS	D03h	STATUS	D83h	STATUS	E03h	STATUS	E83h	STATUS	F03h	STATUS		
C04h	FSR0L	C84h	FSR0L	D04h	FSR0L	D84h	FSR0L	E04h	FSR0L	E84h	FSR0L	F04h	FSR0L		
C05h	FSR0H	C85h	FSR0H	D05h	FSR0H	D85h	FSR0H	E05h	FSR0H	E85h	FSR0H	F05h	FSR0H		
C06h	FSR1L	C86h	FSR1L	D06h	FSR1L	D86h	FSR1L	E06h	FSR1L	E86h	FSR1L	F06h	FSR1L		
C07h	FSR1H	C87h	FSR1H	D07h	FSR1H	D87h	FSR1H	E07h	FSR1H	E87h	FSR1H	F07h	FSR1H		
C08h	BSR	C88h	BSR	D08h	BSR	D88h	BSR	E08h	BSR	E88h	BSR	F08h	BSR		
C09h	WREG	C89h	WREG	D09h	WREG	D89h	WREG	E09h	WREG	E89h	WREG	F09h	WREG		
C0Ah	PCLATH	C8Ah	PCLATH	D0Ah	PCLATH	D8Ah	PCLATH	E0Ah	PCLATH	E8Ah	PCLATH	F0Ah	PCLATH		
C0Bh	INTCON	C8Bh	INTCON	D0Bh	INTCON	D8Bh	INTCON	E0Bh	INTCON	E8Bh	INTCON	F0Bh	INTCON		
C0Ch	—	C8Ch	—	D0Ch	—	D8Ch	—	E0Ch	—	E8Ch	—	F0Ch	—		
C0Dh	—	C8Dh	—	D0Dh	—	D8Dh	—	E0Dh	—	E8Dh	—	F0Dh	—		
C0Eh	—	C8Eh	—	D0Eh	—	D8Eh	—	E0Eh	—	E8Eh	—	F0Eh	—		
C0Fh	—	C8Fh	—	D0Fh	—	D8Fh	—	E0Fh	—	E8Fh	—	F0Fh	—		
C10h	—	C90h	—	D10h	—	D90h	—	E10h	—	E90h	—	F10h	—		
C11h	—	C91h	—	D11h	—	D91h	—	E11h	—	E91h	—	F11h	—		
C12h	—	C92h	—	D12h	—	D92h	—	E12h	—	E92h	—	F12h	—		
C13h	—	C93h	—	D13h	—	D93h	—	E13h	—	E93h	—	F13h	—		
C14h	—	C94h	—	D14h	—	D94h	—	E14h	—	E94h	—	F14h	—		
C15h	—	C95h	—	D15h	—	D95h	—	E15h	—	E95h	—	F15h	—		
C16h	—	C96h	—	D16h	—	D96h	—	E16h	—	E96h	—	F16h	—		
C17h	—	C97h	—	D17h	—	D97h	—	E17h	—	E97h	—	F17h	—		
C18h	—	C98h	—	D18h	—	D98h	—	E18h	—	E98h	—	F18h	—		
C19h	—	C99h	—	D19h	—	D99h	—	E19h	—	E99h	—	F19h	—		
C1Ah	—	C9Ah	—	D1Ah	—	D9Ah	—	E1Ah	—	E9Ah	—	F1Ah	—		
C1Bh	—	C9Bh	—	D1Bh	—	D9Bh	—	E1Bh	—	E9Bh	—	F1Bh	—		
C1Ch	—	C9Ch	—	D1Ch	—	D9Ch	—	E1Ch	—	E9Ch	—	F1Ch	—		
C1Dh	—	C9Dh	—	D1Dh	—	D9Dh	—	E1Dh	—	E9Dh	—	F1Dh	—		
C1Eh	—	C9Eh	—	D1Eh	—	D9Eh	—	E1Eh	—	E9Eh	—	F1Eh	—		
C1Fh	—	C9Fh	—	D1Fh	—	D9Fh	—	E1Fh	—	E9Fh	—	F1Fh	—		
C20h	Unimplemented Read as '0'	CA0h	Unimplemented Read as '0'	D20h	Unimplemented Read as '0'	DA0h	Unimplemented Read as '0'	E20h	Unimplemented Read as '0'	EA0h	Unimplemented Read as '0'	F20h	Unimplemented Read as '0'		
C6Fh	—	CFh	—	D6Fh	—	DFh	—	E6Fh	—	EFh	—	F6Fh	—		
C70h	Accesses 70h – 7Fh	CF0h	Accesses 70h – 7Fh	D70h	Accesses 70h – 7Fh	DF0h	Accesses 70h – 7Fh	E70h	Accesses 70h – 7Fh	EF0h	Accesses 70h – 7Fh	F70h	Accesses 70h – 7Fh		
CFh	—	CFh	—	D7Fh	—	DFh	—	E7Fh	—	EFh	—	F7Fh	—		

Legend: ■ = Unimplemented data memory locations, read as '0'.

PIC16F1829LIN

TABLE 4-5: PIC16F1829LIN MEMORY MAP, BANK 31

Bank 31	
F8Ch	Unimplemented Read as '0'
FE3h	
FE4h	STATUS_SHAD
FE5h	WREG_SHAD
FE6h	BSR_SHAD
FE7h	PCLATH_SHAD
FE8h	FSR0L_SHAD
FE9h	FSR0H_SHAD
FEAh	FSR1L_SHAD
FEBh	FSR1H_SHAD
FEC	—
FEDh	STKPTR
FEEh	TOSL
FEFh	TOSH

Legend: = Unimplemented data memory locations, read as '0'.

PIC16F1829LIN

TABLE 4-6: SPECIAL FUNCTION REGISTER SUMMARY

Address	Name	Bit 7	Bit 6	Bit 5	Bit 4	Bit 3	Bit 2	Bit 1	Bit 0	Value on POR, BOR	Value on all other Resets	
Bank 0												
000h ⁽¹⁾	INDF0	Addressing this location uses contents of FSR0H/FSR0L to address data memory (not a physical register)								xxxx xxxx	xxxx xxxx	
001h ⁽¹⁾	INDF1	Addressing this location uses contents of FSR1H/FSR1L to address data memory (not a physical register)								xxxx xxxx	xxxx xxxx	
002h ⁽¹⁾	PCL	Program Counter (PC) Least Significant Byte								0000 0000	0000 0000	
003h ⁽¹⁾	STATUS	—	—	—	\overline{TO}	\overline{PD}	Z	DC	C	---1 1000	---q quuu	
004h ⁽¹⁾	FSR0L	Indirect Data Memory Address 0 Low Pointer								0000 0000	uuuu uuuu	
005h ⁽¹⁾	FSR0H	Indirect Data Memory Address 0 High Pointer								0000 0000	0000 0000	
006h ⁽¹⁾	FSR1L	Indirect Data Memory Address 1 Low Pointer								0000 0000	uuuu uuuu	
007h ⁽¹⁾	FSR1H	Indirect Data Memory Address 1 High Pointer								0000 0000	0000 0000	
008h ⁽¹⁾	BSR	—	—	—	BSR<4:0>				—	---0 0000	---0 0000	
009h ⁽¹⁾	WREG	Working Register								0000 0000	uuuu uuuu	
00Ah ⁽¹⁾	PCLATH	—	Write Buffer for the upper 7 bits of the Program Counter								-000 0000	-000 0000
00Bh ⁽¹⁾	INTCON	GIE	PEIE	TMR0IE	INTE	IOCIE	TMR0IF	INTF	IOCIF	0000 0000	0000 0000	
00Ch	PORTA	—	—	RA5	RA4	RA3	RA2	RA1	RA0	--xx xxxx	--xx xxxx	
00Dh⁽²⁾	PORTB	LINTX	LINCS	LINRX	RB4	—	—	—	—	xxxx ----	xxxx ----	
00Eh⁽²⁾	PORTC	PWRGD	—	RC5	RC4	RC3	RC2	RC1	RC0	xxxx xxxx	xxxx xxxx	
00Fh	—	Unimplemented								—	—	
010h	—	Unimplemented								—	—	
011h	PIR1	TMR1GIF	ADIF	RCIF	TXIF	SSP1IF	CCP1IF	TMR2IF	TMR1IF	0000 0000	0000 0000	
012h	PIR2	OSFIF	C2IF	C1IF	EEIF	BCL1IF	—	—	CCP2IF	0000 0--0	0000 0--0	
013h	PIR3	—	—	CCP4IF	CCP3IF	TMR6IF	—	TMR4IF	—	--00 0-0-	--00 0-0-	
014h	PIR4	—	—	—	—	—	—	BCL2IF	SSP2IF	---- --00	---- --00	
015h	TMR0	Timer0 Module Register								xxxx xxxx	uuuu uuuu	
016h	TMR1L	Holding Register for the Least Significant Byte of the 16-bit TMR1 Register								xxxx xxxx	uuuu uuuu	
017h	TMR1H	Holding Register for the Most Significant Byte of the 16-bit TMR1 Register								xxxx xxxx	uuuu uuuu	
018h	T1CON	TMR1CS1	TMR1CS0	T1CKPS<1:0>		T1OSCEN	$\overline{T1SYNC}$	—	TMR1ON	0000 00-0	uuuu uu-u	
019h	T1GCON	TMR1GE	T1GPOL	T1GTM	T1GSPM	T1GGO/DONE	T1GVAL	T1GSS<1:0>		0000 0x00	uuuu uxuu	
01Ah	TMR2	Timer2 Module Register								0000 0000	0000 0000	
01Bh	PR2	Timer2 Period Register								1111 1111	1111 1111	
01Ch	T2CON	—	T2OUTPS<3:0>				TMR2ON	T2CKPS<1:0>		-000 0000	-000 0000	
01Dh	—	Unimplemented								—	—	
01Eh	CPSCON0	CPSON	CPSRM	—	—	CPSRNG<1:0>		CPSOUT	T0XCS	00-- 0000	00-- 0000	
01Fh	CPSCON1	—	—	—	—	CPSCH<3:0>				---- 0000	---- 0000	

Legend: x = unknown, u = unchanged, q = value depends on condition, - = unimplemented, r = reserved.
Shaded locations are unimplemented, read as '0'.

Note 1: These registers can be addressed from any bank.

Note 2: Registers in bold have functional differences. Please refer to the appropriate chapters in the data sheet for details.

PIC16F1829LIN

TABLE 4-6: SPECIAL FUNCTION REGISTER SUMMARY (CONTINUED)

Address	Name	Bit 7	Bit 6	Bit 5	Bit 4	Bit 3	Bit 2	Bit 1	Bit 0	Value on POR, BOR	Value on all other Resets	
Bank 1												
080h ⁽¹⁾	INDF0	Addressing this location uses contents of FSR0H/FSR0L to address data memory (not a physical register)								xxxx xxxx	xxxx xxxx	
081h ⁽¹⁾	INDF1	Addressing this location uses contents of FSR1H/FSR1L to address data memory (not a physical register)								xxxx xxxx	xxxx xxxx	
082h ⁽¹⁾	PCL	Program Counter (PC) Least Significant Byte								0000 0000	0000 0000	
083h ⁽¹⁾	STATUS	—	—	—	\overline{TO}	\overline{PD}	Z	DC	C	---1 1000	---q quuu	
084h ⁽¹⁾	FSR0L	Indirect Data Memory Address 0 Low Pointer								0000 0000	uuuu uuuu	
085h ⁽¹⁾	FSR0H	Indirect Data Memory Address 0 High Pointer								0000 0000	0000 0000	
086h ⁽¹⁾	FSR1L	Indirect Data Memory Address 1 Low Pointer								0000 0000	uuuu uuuu	
087h ⁽¹⁾	FSR1H	Indirect Data Memory Address 1 High Pointer								0000 0000	0000 0000	
088h ⁽¹⁾	BSR	—	—	—	BSR<4:0>			—	—	---0 0000	---0 0000	
089h ⁽¹⁾	WREG	Working Register								0000 0000	uuuu uuuu	
08Ah ⁽¹⁾	PCLATH	—	Write Buffer for the upper 7 bits of the Program Counter								-000 0000	-000 0000
08Bh ⁽¹⁾	INTCON	GIE	PEIE	TMR0IE	INTE	IOCIE	TMR0IF	INTF	IOCIF	0000 0000	0000 0000	
08Ch	TRISA	—	—	TRISA5	TRISA4	TRISA3	TRISA2	TRISA1	TRISA0	--11 1111	--11 1111	
08Dh⁽²⁾	TRISB	TRISB7	TRISB6	TRISB5	TRISB4	—	—	—	—	1111 ----	1111 ----	
08Eh⁽²⁾	TRISC	TRISC7	TRISC6	TRISC5	TRISC4	TRISC3	TRISC2	TRISC1	TRISC0	1111 1111	1111 1111	
08Fh	—	Unimplemented								—	—	
090h	—	Unimplemented								—	—	
091h⁽²⁾	PIE1	TMR1GIE	ADIE	RCIE	TXIE	SSP1IE	CCP1IE	TMR2IE	TMR1IE	0000 0000	0000 0000	
092h	PIE2	OSFIE	C2IE	C1IE	EEIE	BCL1IE	—	—	CCP2IE	0000 0--0	0000 0--0	
093h	PIE3	—	—	CCP4IE	CCP3IE	TMR6IE	—	TMR4IE	—	--00 0-0-	--00 0-0-	
094h⁽²⁾	PIE4	—	—	—	—	—	—	BCL2IE	SSP2IE	---- --00	---- --00	
095h	OPTION_REG	\overline{WPUEN}	INTEDG	TMR0CS	TMR0SE	PSA	PS<2:0>			1111 1111	1111 1111	
096h	PCON	STKOVF	STKUNF	—	—	\overline{RMCLR}	\overline{RI}	\overline{POR}	\overline{BOR}	00-- 11qq	qq-- qquu	
097h	WDTCON	—	—	WDTPS<4:0>				—	SWDTEN	--01 0110	--01 0110	
098h	OSCTUNE	—	—	TUN<5:0>				—	—	--00 0000	--00 0000	
099h	OSCCON	SPLLEN	IRCF<3:0>			—	SCS<1:0>			0011 1-00	0011 1-00	
09Ah	OSCSTAT	T1OSCR	PLL	OSTS	HFIOFR	HFIOFL	MFIOFR	LFIOFR	HFIOFS	10q0 0q00	qqqq qq0q	
09Bh	ADRESL	A/D Result Register Low								xxxx xxxx	uuuu uuuu	
09Ch	ADRESH	A/D Result Register High								xxxx xxxx	uuuu uuuu	
09Dh	ADCON0	—	CHS<4:0>				—	$\overline{GO/DONE}$	ADON	-000 0000	-000 0000	
09Eh	ADCON1	ADFM	ADCS<2:0>		—	ADNREF	ADPREF<1:0>			0000 -000	0000 -000	
09Fh	—	Unimplemented								—	—	

Legend: x = unknown, u = unchanged, q = value depends on condition, - = unimplemented, r = reserved.
Shaded locations are unimplemented, read as '0'.

- Note** 1: These registers can be addressed from any bank.
2: Registers in bold have functional differences. Please refer to the appropriate chapters in the data sheet for details.

PIC16F1829LIN

TABLE 4-6: SPECIAL FUNCTION REGISTER SUMMARY (CONTINUED)

Address	Name	Bit 7	Bit 6	Bit 5	Bit 4	Bit 3	Bit 2	Bit 1	Bit 0	Value on POR, BOR	Value on all other Resets	
Bank 2												
100h ⁽¹⁾	INDF0	Addressing this location uses contents of FSR0H/FSR0L to address data memory (not a physical register)								xxxx xxxx	xxxx xxxx	
101h ⁽¹⁾	INDF1	Addressing this location uses contents of FSR1H/FSR1L to address data memory (not a physical register)								xxxx xxxx	xxxx xxxx	
102h ⁽¹⁾	PCL	Program Counter (PC) Least Significant Byte								0000 0000	0000 0000	
103h ⁽¹⁾	STATUS	—	—	—	\overline{TO}	\overline{PD}	Z	DC	C	---1 1000	---q quuu	
104h ⁽¹⁾	FSR0L	Indirect Data Memory Address 0 Low Pointer								0000 0000	uuuu uuuu	
105h ⁽¹⁾	FSR0H	Indirect Data Memory Address 0 High Pointer								0000 0000	0000 0000	
106h ⁽¹⁾	FSR1L	Indirect Data Memory Address 1 Low Pointer								0000 0000	uuuu uuuu	
107h ⁽¹⁾	FSR1H	Indirect Data Memory Address 1 High Pointer								0000 0000	0000 0000	
108h ⁽¹⁾	BSR	—	—	—	BSR<4:0>				---	0000	---	0000
109h ⁽¹⁾	WREG	Working Register								0000 0000	uuuu uuuu	
10Ah ⁽¹⁾	PCLATH	—	Write Buffer for the upper 7 bits of the Program Counter								-000 0000	-000 0000
10Bh ⁽¹⁾	INTCON	GIE	PEIE	TMR0IE	INTE	IOCIE	TMR0IF	INTF	IOCIF	0000 0000	0000 0000	
10Ch	LATA	—	—	LATA5	LATA4	—	LATA2	LATA1	LATA0	--xx -xxx	--uu -uuu	
10Dh⁽²⁾	LATB	LATB7	LATB6	LATB5	LATB4	—	—	—	—	xxxx ----	xxxx ----	
10Eh⁽²⁾	LATC	PWRGD	—	LATC5	LATC4	LATC3	LATC2	LATC1	LATC0	xxxx xxxx	uuuu uuuu	
10Fh	—	Unimplemented								—	—	
110h	—	Unimplemented								—	—	
111h	CM1CON0	C1ON	C1OUT	C1OE	C1POL	—	C1SP	C1HYS	C1SYNC	0000 -100	0000 -100	
112h	CM1CON1	C1INTP	C1INTN	C1PCH<1:0>		—	—	C1NCH1	C1NCH0	0000 ---0	0000 ---0	
113h	CM2CON0	C2ON	C2OUT	C2OE	C2POL	—	C2SP	C2HYS	C2SYNC	0000 -100	0000 -100	
114h	CM2CON1	C2INTP	C2INTN	C2PCH<1:0>		—	—	C2NCH<1:0>		0000 --00	0000 --00	
115h	CMOUT	—	—	—	—	—	—	MC2OUT	MC1OUT	---- --00	---- --00	
116h	BORCON	SBOREN	—	—	—	—	—	—	BORRDY	1--- ---q	u--- ---u	
117h	FVRCON	FVREN	FVRRDY	TSEN	TSRNG	CDAFVR<1:0>		ADFVR<1:0>		0q00 0000	0q00 0000	
118h	DACCON0	DACEN	DACLPS	DACOE	—	DACPSS<1:0>		—	DACNSS	000- 00-0	000- 00-0	
119h	DACCON1	—	—	—	DACR<4:0>				---	0000	---	0000
11Ah	SRCON0	SRLEN	SRCLK<2:0>			SRQEN	SRNQEN	SRPS	SRPR	0000 0000	0000 0000	
11Bh	SRCON1	SRSPE	SRSCKE	SRSC2E	SRSC1E	SRRPE	SRRCKE	SRR2E	SRR1E	0000 0000	0000 0000	
11Ch	—	Unimplemented								—	—	
11Dh⁽²⁾	APFCON0	RXDTSEL	—	—	—	T1GSEL	TXCKSEL	—	—	000- 0000	000- 0000	
11Eh⁽²⁾	APFCON1	—	—	—	—	P1DSEL	P1CSEL	P2BSEL	CCP2SEL	--00 0000	--00 0000	
11Fh	—	Unimplemented								—	—	

Legend: x = unknown, u = unchanged, q = value depends on condition, - = unimplemented, r = reserved.
Shaded locations are unimplemented, read as '0'.

Note 1: These registers can be addressed from any bank.

Note 2: Registers in bold have functional differences. Please refer to the appropriate chapters in the data sheet for details.

PIC16F1829LIN

TABLE 4-6: SPECIAL FUNCTION REGISTER SUMMARY (CONTINUED)

Address	Name	Bit 7	Bit 6	Bit 5	Bit 4	Bit 3	Bit 2	Bit 1	Bit 0	Value on POR, BOR	Value on all other Resets	
Bank 3												
180h ⁽¹⁾	INDF0	Addressing this location uses contents of FSR0H/FSR0L to address data memory (not a physical register)								xxxx xxxx	xxxx xxxx	
181h ⁽¹⁾	INDF1	Addressing this location uses contents of FSR1H/FSR1L to address data memory (not a physical register)								xxxx xxxx	xxxx xxxx	
182h ⁽¹⁾	PCL	Program Counter (PC) Least Significant Byte								0000 0000	0000 0000	
183h ⁽¹⁾	STATUS	—	—	—	\overline{TO}	\overline{PD}	Z	DC	C	---1 1000	---q quuu	
184h ⁽¹⁾	FSR0L	Indirect Data Memory Address 0 Low Pointer								0000 0000	uuuu uuuu	
185h ⁽¹⁾	FSR0H	Indirect Data Memory Address 0 High Pointer								0000 0000	0000 0000	
186h ⁽¹⁾	FSR1L	Indirect Data Memory Address 1 Low Pointer								0000 0000	uuuu uuuu	
187h ⁽¹⁾	FSR1H	Indirect Data Memory Address 1 High Pointer								0000 0000	0000 0000	
188h ⁽¹⁾	BSR	—	—	—	BSR<4:0>			—	—	---0 0000	---0 0000	
189h ⁽¹⁾	WREG	Working Register								0000 0000	uuuu uuuu	
18Ah ⁽¹⁾	PCLATH	—	Write Buffer for the upper 7 bits of the Program Counter								-000 0000	-000 0000
18Bh ⁽¹⁾	INTCON	GIE	PEIE	TMR0IE	INTE	IOCFIE	TMR0IF	INTF	IOCFIF	0000 0000	0000 0000	
18Ch	ANSELA	—	—	—	ANSA4	—	ANSA2	ANSA1	ANSA0	---1 -111	---1 -111	
18Dh ⁽²⁾	ANSELB	ANSB7	ANSB6	ANSB5	ANSB4	—	—	—	—	1111 ----	1111 ----	
18Eh ⁽²⁾	ANSELC	ANSC7	—	—	—	ANSC3	ANSC2	ANSC1	ANSC0	11-- 1111	11-- 1111	
18Fh	—	Unimplemented								—	—	
190h	—	Unimplemented								—	—	
191h	EEADRL	EEPROM / Program Memory Address Register Low Byte								0000 0000	0000 0000	
192h	EEADRH	—	EEPROM / Program Memory Address Register High Byte								-000 0000	-000 0000
193h	EEDATL	EEPROM / Program Memory Read Data Register Low Byte								xxxx xxxx	uuuu uuuu	
194h	EEDATH	—	—	EEPROM / Program Memory Read Data Register High Byte						--xx xxxx	--uu uuuu	
195h	EECON1	EEPGD	CFGS	LWLO	FREE	WRERR	WREN	WR	RD	0000 x000	0000 q000	
196h	EECON2	EEPROM control register 2								0000 0000	0000 0000	
197h	—	Unimplemented								—	—	
198h	—	Unimplemented								—	—	
199h	RCREG	EUSART Receive Data Register								0000 0000	0000 0000	
19Ah	TXREG	EUSART Transmit Data Register								0000 0000	0000 0000	
19Bh	SPBRGL	BRG<7:0>								0000 0000	0000 0000	
19Ch	SPBRGH	BRG<15:8>								0000 0000	0000 0000	
19Dh	RCSTA	SPEN	RX9	SREN	CREN	ADDEN	FERR	OERR	RX9D	0000 000x	0000 000x	
19Eh	TXSTA	CSRC	TX9	TXEN	SYNC	SEnDB	BRGH	TRMT	TX9D	0000 0010	0000 0010	
19Fh ⁽²⁾	BAUDCON	ABDOVF	RCIDL	—	SCKP	BRG16	—	WUE	ABDEN	01-0 0-00	01-0 0-00	

Legend: x = unknown, u = unchanged, q = value depends on condition, - = unimplemented, r = reserved.
Shaded locations are unimplemented, read as '0'.

- Note** 1: These registers can be addressed from any bank.
2: Registers in bold have functional differences. Please refer to the appropriate chapters in the data sheet for details.

PIC16F1829LIN

TABLE 4-6: SPECIAL FUNCTION REGISTER SUMMARY (CONTINUED)

Address	Name	Bit 7	Bit 6	Bit 5	Bit 4	Bit 3	Bit 2	Bit 1	Bit 0	Value on POR, BOR	Value on all other Resets	
Bank 4												
200h ⁽¹⁾	INDF0	Addressing this location uses contents of FSR0H/FSR0L to address data memory (not a physical register)								xxxx xxxx	xxxx xxxx	
201h ⁽¹⁾	INDF1	Addressing this location uses contents of FSR1H/FSR1L to address data memory (not a physical register)								xxxx xxxx	xxxx xxxx	
202h ⁽¹⁾	PCL	Program Counter (PC) Least Significant Byte								0000 0000	0000 0000	
203h ⁽¹⁾	STATUS	—	—	—	\overline{TO}	\overline{PD}	Z	DC	C	---1 1000	---q quuu	
204h ⁽¹⁾	FSR0L	Indirect Data Memory Address 0 Low Pointer								0000 0000	uuuu uuuu	
205h ⁽¹⁾	FSR0H	Indirect Data Memory Address 0 High Pointer								0000 0000	0000 0000	
206h ⁽¹⁾	FSR1L	Indirect Data Memory Address 1 Low Pointer								0000 0000	uuuu uuuu	
207h ⁽¹⁾	FSR1H	Indirect Data Memory Address 1 High Pointer								0000 0000	0000 0000	
208h ⁽¹⁾	BSR	—	—	—	BSR<4:0>				---	0000	---	0000
209h ⁽¹⁾	WREG	Working Register								0000 0000	uuuu uuuu	
20Ah ⁽¹⁾	PCLATH	—	Write Buffer for the upper 7 bits of the Program Counter								-000 0000	-000 0000
20Bh ⁽¹⁾	INTCON	GIE	PEIE	TMR0IE	INTE	IOCFE	TMR0IF	INTF	IOCF	0000 0000	0000 0000	
20Ch	WPUA	—	—	WPUA5	WPUA4	WPUA3	WPUA2	WPUA1	WPUA0	--11 1111	--11 1111	
20Dh ⁽²⁾	WPUB	WPUB7	WPUB6	WPUB5	WPUB4	—	—	—	—	1111 ----	1111 ----	
20Eh ⁽²⁾	WPUC	WPUC7	WPUC6	WPUC5	WPUC4	WPUC3	WPUC2	WPUC1	WPUC0	1111 1111	1111 1111	
20Fh	—	Unimplemented								—	—	
210h	—	Unimplemented								—	—	
211h ⁽²⁾	SSP1BUF	Don't care								xxxx xxxx	uuuu uuuu	
212h ⁽²⁾	SSP1ADD	Don't care								0000 0000	0000 0000	
213h ⁽²⁾	SSP1MSK	Don't care								1111 1111	1111 1111	
214h ⁽²⁾	SSP1STAT	0	0	0	0	0	0	0	0	0000 0000	0000 0000	
215h ⁽²⁾	SSP1CON1	0	0	0	0	0000			0000 0000	0000 0000		
216h ⁽²⁾	SSP1CON2	0	0	0	0	0	0	0	0	0000 0000	0000 0000	
217h ⁽²⁾	SSP1CON3	0	0	0	0	0	0	0	0	0000 0000	0000 0000	
218h	—	Unimplemented								—	—	
219h ⁽²⁾	SSP2BUF	Don't care								xxxx xxxx	uuuu uuuu	
21Ah ⁽²⁾	SSP2ADD	Don't care								0000 0000	0000 0000	
21Bh ⁽²⁾	SSP2MSK	Don't care								1111 1111	1111 1111	
21Ch ⁽²⁾	SSP2STAT	0	0	0	0	0	0	0	0	0000 0000	0000 0000	
21Dh ⁽²⁾	SSP2CON1	0	0	0	0	0000			0000 0000	0000 0000		
21Eh ⁽²⁾	SSP2CON2	0	0	0	0	0	0	0	0	0000 0000	0000 0000	
21Fh ⁽²⁾	SSP2CON3	0	0	0	0	0	0	0	0	0000 0000	0000 0000	

Legend: x = unknown, u = unchanged, q = value depends on condition, - = unimplemented, r = reserved.
Shaded locations are unimplemented, read as '0'.

Note 1: These registers can be addressed from any bank.
2: Registers in bold have functional differences. Please refer to the appropriate chapters in the data sheet for details.

PIC16F1829LIN

TABLE 4-6: SPECIAL FUNCTION REGISTER SUMMARY (CONTINUED)

Address	Name	Bit 7	Bit 6	Bit 5	Bit 4	Bit 3	Bit 2	Bit 1	Bit 0	Value on POR, BOR	Value on all other Resets	
Bank 5												
280h ⁽¹⁾	INDF0	Addressing this location uses contents of FSR0H/FSR0L to address data memory (not a physical register)								xxxx xxxx	xxxx xxxx	
281h ⁽¹⁾	INDF1	Addressing this location uses contents of FSR1H/FSR1L to address data memory (not a physical register)								xxxx xxxx	xxxx xxxx	
282h ⁽¹⁾	PCL	Program Counter (PC) Least Significant Byte								0000 0000	0000 0000	
283h ⁽¹⁾	STATUS	—	—	—	\overline{TO}	\overline{PD}	Z	DC	C	---1 1000	---q quuu	
284h ⁽¹⁾	FSR0L	Indirect Data Memory Address 0 Low Pointer								0000 0000	uuuu uuuu	
285h ⁽¹⁾	FSR0H	Indirect Data Memory Address 0 High Pointer								0000 0000	0000 0000	
286h ⁽¹⁾	FSR1L	Indirect Data Memory Address 1 Low Pointer								0000 0000	uuuu uuuu	
287h ⁽¹⁾	FSR1H	Indirect Data Memory Address 1 High Pointer								0000 0000	0000 0000	
288h ⁽¹⁾	BSR	—	—	—	BSR<4:0>					---0 0000	---0 0000	
289h ⁽¹⁾	WREG	Working Register								0000 0000	uuuu uuuu	
28Ah ⁽¹⁾	PCLATH	—	Write Buffer for the upper 7 bits of the Program Counter								-000 0000	-000 0000
28Bh ⁽¹⁾	INTCON	GIE	PEIE	TMR0IE	INTE	IOCIE	TMR0IF	INTF	IOCIF	0000 0000	0000 0000	
28Ch	—	Unimplemented								—	—	
28Dh	—	Unimplemented								—	—	
28Eh	—	Unimplemented								—	—	
28Fh	—	Unimplemented								—	—	
290h	—	Unimplemented								—	—	
291h	CCPR1L	Capture/Compare/PWM Register 1 (LSB)								xxxx xxxx	uuuu uuuu	
292h	CCPR1H	Capture/Compare/PWM Register 1 (MSB)								xxxx xxxx	uuuu uuuu	
293h	CCP1CON	P1M<1:0>		DC1B<1:0>		CCP1M<3:0>				0000 0000	0000 0000	
294h	PWM1CON	P1RSEN	P1DC<6:0>								0000 0000	0000 0000
295h	CCP1AS	CCP1ASE	CCP1AS<2:0>			PSS1AC<1:0>		PSS1BD<1:0>		0000 0000	0000 0000	
296h	PSTR1CON	—	—	—	STR1SYNC	STR1D	STR1C	STR1B	STR1A	---0 0001	---0 0001	
297h	—	Unimplemented								—	—	
298h	CCPR2L	Capture/Compare/PWM Register 2 (LSB)								xxxx xxxx	uuuu uuuu	
299h	CCPR2H	Capture/Compare/PWM Register 2 (MSB)								xxxx xxxx	uuuu uuuu	
29Ah	CCP2CON	P2M1	P2M0	DC2B1	DC2B0	CCP2M3	CCP2M2	CCP2M1	CCP2M0	0000 0000	0000 0000	
29Bh	PWM2CON	P2RSEN	P2DC6	P2DC5	P2DC4	P2DC3	P2DC2	P2DC1	P2DC0	0000 0000	0000 0000	
29Ch	CCP2AS	CCP2ASE	CCP2AS2	CCP2AS1	CCP2AS0	PSS2AC1	PSS2AC0	PSS2BD1	PSS2BD0	0000 0000	0000 0000	
29Dh	PSTR2CON	—	—	—	STR2SYNC	STR2D	STR2C	STR2B	STR2A	---0 0001	---0 0001	
29Eh ⁽²⁾	CCPTMRS	0	C4TSEL0	C3TSEL1	C3TSEL0	C2TSEL1	C2TSEL0	C1TSEL1	C1TSEL0	0000 0000	0000 0000	
29Fh	—	Unimplemented								—	—	

Legend: x = unknown, u = unchanged, q = value depends on condition, - = unimplemented, r = reserved.
Shaded locations are unimplemented, read as '0'.

Note 1: These registers can be addressed from any bank.

2: Registers in bold have functional differences. Please refer to the appropriate chapters in the data sheet for details.

PIC16F1829LIN

TABLE 4-6: SPECIAL FUNCTION REGISTER SUMMARY (CONTINUED)

Address	Name	Bit 7	Bit 6	Bit 5	Bit 4	Bit 3	Bit 2	Bit 1	Bit 0	Value on POR, BOR	Value on all other Resets	
Bank 6												
300h ⁽¹⁾	INDF0	Addressing this location uses contents of FSR0H/FSR0L to address data memory (not a physical register)								xxxx xxxx	xxxx xxxx	
301h ⁽¹⁾	INDF1	Addressing this location uses contents of FSR1H/FSR1L to address data memory (not a physical register)								xxxx xxxx	xxxx xxxx	
302h ⁽¹⁾	PCL	Program Counter (PC) Least Significant Byte								0000 0000	0000 0000	
303h ⁽¹⁾	STATUS	—	—	—	\overline{TO}	\overline{PD}	Z	DC	C	---1 1000	---q quuu	
304h ⁽¹⁾	FSR0L	Indirect Data Memory Address 0 Low Pointer								0000 0000	uuuu uuuu	
305h ⁽¹⁾	FSR0H	Indirect Data Memory Address 0 High Pointer								0000 0000	0000 0000	
306h ⁽¹⁾	FSR1L	Indirect Data Memory Address 1 Low Pointer								0000 0000	uuuu uuuu	
307h ⁽¹⁾	FSR1H	Indirect Data Memory Address 1 High Pointer								0000 0000	0000 0000	
308h ⁽¹⁾	BSR	—	—	—	BSR<4:0>					---0 0000	---0 0000	
309h ⁽¹⁾	WREG	Working Register								0000 0000	uuuu uuuu	
30Ah ⁽¹⁾	PCLATH	—	Write Buffer for the upper 7 bits of the Program Counter								-000 0000	-000 0000
30Bh ⁽¹⁾	INTCON	GIE	PEIE	TMR0IE	INTE	IOCFIE	TMR0IF	INTF	IOCF	0000 0000	0000 0000	
30Ch	—	Unimplemented								—	—	
30Dh	—	Unimplemented								—	—	
30Eh	—	Unimplemented								—	—	
30Fh	—	Unimplemented								—	—	
310h	—	Unimplemented								—	—	
311h	CCPR3L	Capture/Compare/PWM Register 3 (LSB)								xxxx xxxx	uuuu uuuu	
312h	CCPR3H	Capture/Compare/PWM Register 3 (MSB)								xxxx xxxx	uuuu uuuu	
313h	CCP3CON	—	—	DC3B1	DC3B0	CCP3M3	CCP3M2	CCP3M1	CCP3M0	--00 0000	--00 0000	
314h	—	Unimplemented								—	—	
315h	—	Unimplemented								—	—	
316h	—	Unimplemented								—	—	
317h	—	Unimplemented								—	—	
318h	CCPR4L	Capture/Compare/PWM Register 4 (LSB)								xxxx xxxx	uuuu uuuu	
319h	CCPR4H	Capture/Compare/PWM Register 4 (MSB)								xxxx xxxx	uuuu uuuu	
31Ah	CCP4CON	P4M1	P4M0	DC4B1	DC4B0	CCP4M3	CCP4M2	CCP4M1	CCP4M0	--00 0000	--00 0000	
31Bh	—	Unimplemented								—	—	
31Ch	—	Unimplemented								—	—	
31Dh	—	Unimplemented								—	—	
31Eh	—	Unimplemented								—	—	
31Fh	—	Unimplemented								—	—	

Legend: x = unknown, u = unchanged, q = value depends on condition, - = unimplemented, r = reserved.
Shaded locations are unimplemented, read as '0'.

Note 1: These registers can be addressed from any bank.
2: Registers in bold have functional differences. Please refer to the appropriate chapters in the data sheet for details.

PIC16F1829LIN

TABLE 4-6: SPECIAL FUNCTION REGISTER SUMMARY (CONTINUED)

Address	Name	Bit 7	Bit 6	Bit 5	Bit 4	Bit 3	Bit 2	Bit 1	Bit 0	Value on POR, BOR	Value on all other Resets	
Bank 7												
380h ⁽¹⁾	INDF0	Addressing this location uses contents of FSR0H/FSR0L to address data memory (not a physical register)								xxxx xxxx	xxxx xxxx	
381h ⁽¹⁾	INDF1	Addressing this location uses contents of FSR1H/FSR1L to address data memory (not a physical register)								xxxx xxxx	xxxx xxxx	
382h ⁽¹⁾	PCL	Program Counter (PC) Least Significant Byte								0000 0000	0000 0000	
383h ⁽¹⁾	STATUS	—	—	—	\overline{TO}	\overline{PD}	Z	DC	C	---1 1000	---q quuu	
384h ⁽¹⁾	FSR0L	Indirect Data Memory Address 0 Low Pointer								0000 0000	uuuu uuuu	
385h ⁽¹⁾	FSR0H	Indirect Data Memory Address 0 High Pointer								0000 0000	0000 0000	
386h ⁽¹⁾	FSR1L	Indirect Data Memory Address 1 Low Pointer								0000 0000	uuuu uuuu	
387h ⁽¹⁾	FSR1H	Indirect Data Memory Address 1 High Pointer								0000 0000	0000 0000	
388h ⁽¹⁾	BSR	—	—	—	BSR<4:0>			---	0000	---	0000	
389h ⁽¹⁾	WREG	Working Register								0000 0000	uuuu uuuu	
38Ah ⁽¹⁾	PCLATH	—	Write Buffer for the upper 7 bits of the Program Counter								-000 0000	-000 0000
38Bh ⁽¹⁾	INTCON	GIE	PEIE	TMR0IE	INTE	IOCFIE	TMR0IF	INTF	IOCFIF	0000 0000	0000 0000	
38Ch	INLVLA	—	—	INLVLA5	INLVLA4	INLVLA3	INLVLA2	INLVLA1	INLVLA0	--00 0100	--00 0100	
38Dh	INVLVB	INVLVB7	INVLVB6	INVLVB5	INVLVB4	—	—	—	—	0000 ----	0000 ----	
38Eh	INLVLC	INLVLC7	INLVLC6	INLVLC5	INLVLC4	INLVLC3	INLVLC2	INLVLC1	INLVLC0	11xx xxxx	11xx xxxx	
38Fh	—	Unimplemented								—	—	
390h	—	Unimplemented								—	—	
391h	IOCAP	—	—	IOCAP5	IOCAP4	IOCAP3	IOCAP2	IOCAP1	IOCAP0	--00 0000	--00 0000	
392h	IOCAN	—	—	IOCAN5	IOCAN4	IOCAN3	IOCAN2	IOCAN1	IOCAN0	--00 0000	--00 0000	
393h	IOCAF	—	—	IOCAF5	IOCAF4	IOCAF3	IOCAF2	IOCAF1	IOCAF0	--00 0000	--00 0000	
394h	IOCBP	IOCBP7	IOCBP6	IOCBP5	IOCBP4	—	—	—	—	0000 ----	0000 ----	
395h	IOCBN	IOCBN7	IOCBN6	IOCBN5	IOCBN4	—	—	—	—	0000 ----	0000 ----	
396h	IOCBF	IOCBF7	IOCBF6	IOCBF5	IOCBF4	—	—	—	—	0000 ----	0000 ----	
397h	—	Unimplemented								—	—	
398h	—	Unimplemented								—	—	
399h	—	Unimplemented								—	—	
39Ah	CLKRCON	CLKREN	CLKROE	CLKRSLR	CLKRDC<1:0>		CLKRDIV<2:0>			0011 0000	0011 0000	
39Bh	—	Unimplemented								—	—	
39Ch	MDCON	MDEN	MDOE	MDSLR	MDOPOL	MDOOUT	—	—	MDBIT	0010 ---0	0010 ---0	
39Dh	MDSRC	MDMSODIS	—	—	—	MDMS<3:0>			x--- xxxx	u--- uuuu		
39Eh	MDCARL	MDCLDIS	MDCLPOL	MDCLSYNC	—	MDCL<3:0>			xxx- xxxx	uuu- uuuu		
39Fh	MDCARH	MDCHDIS	MDCHPOL	MDCHSYNC	—	MDCH<3:0>			xxx- xxxx	uuu- uuuu		

Legend: x = unknown, u = unchanged, q = value depends on condition, - = unimplemented, r = reserved.
Shaded locations are unimplemented, read as '0'.

- Note** 1: These registers can be addressed from any bank.
2: Registers in bold have functional differences. Please refer to the appropriate chapters in the data sheet for details.

PIC16F1829LIN

TABLE 4-6: SPECIAL FUNCTION REGISTER SUMMARY (CONTINUED)

Address	Name	Bit 7	Bit 6	Bit 5	Bit 4	Bit 3	Bit 2	Bit 1	Bit 0	Value on POR, BOR	Value on all other Resets	
Bank 8												
400h ⁽¹⁾	INDF0	Addressing this location uses contents of FSR0H/FSR0L to address data memory (not a physical register)								xxxx xxxx	xxxx xxxx	
401h ⁽¹⁾	INDF1	Addressing this location uses contents of FSR1H/FSR1L to address data memory (not a physical register)								xxxx xxxx	xxxx xxxx	
402h ⁽¹⁾	PCL	Program Counter (PC) Least Significant Byte								0000 0000	0000 0000	
403h ⁽¹⁾	STATUS	—	—	—	\overline{TO}	\overline{PD}	Z	DC	C	---1 1000	---q quuu	
404h ⁽¹⁾	FSR0L	Indirect Data Memory Address 0 Low Pointer								0000 0000	uuuu uuuu	
405h ⁽¹⁾	FSR0H	Indirect Data Memory Address 0 High Pointer								0000 0000	0000 0000	
406h ⁽¹⁾	FSR1L	Indirect Data Memory Address 1 Low Pointer								0000 0000	uuuu uuuu	
407h ⁽¹⁾	FSR1H	Indirect Data Memory Address 1 High Pointer								0000 0000	0000 0000	
408h ⁽¹⁾	BSR	—	—	—	BSR<4:0>			---	0000	---	0000	
409h ⁽¹⁾	WREG	Working Register								0000 0000	uuuu uuuu	
40Ah ⁽¹⁾	PCLATH	—	Write Buffer for the upper 7 bits of the Program Counter								-000 0000	-000 0000
40Bh ⁽¹⁾	INTCON	GIE	PEIE	TMR0IE	INTE	IOCFIE	TMR0IF	INTF	IOCFIF	0000 0000	0000 0000	
40Ch	—	Unimplemented								—	—	
40Dh	—	Unimplemented								—	—	
40Eh	—	Unimplemented								—	—	
40Fh	—	Unimplemented								—	—	
410h	—	Unimplemented								—	—	
411h	—	Unimplemented								—	—	
412h	—	Unimplemented								—	—	
413h	—	Unimplemented								—	—	
414h	—	Unimplemented								—	—	
415h	TMR4	Timer4 Module Register								0000 0000	0000 0000	
416h	PR4	Timer4 Period Register								1111 1111	1111 1111	
417h	T4CON	—	T4OUTPS<3:0>			TMR4ON	T4CKPS<1:0>		---	0000	---	0000
418h	—	Unimplemented								—	—	
419h	—	Unimplemented								—	—	
41Ah	—	Unimplemented								—	—	
41Bh	—	Unimplemented								—	—	
41Ch	TMR6	Timer6 Module Register								0000 0000	0000 0000	
41Dh	PR6	Timer6 Period Register								1111 1111	1111 1111	
41Eh	T6CON	—	T6OUTPS<3:0>			TMR6ON	T6CKPS<1:0>		---	0000	---	0000
41Fh	—	Unimplemented								—	—	

Legend: x = unknown, u = unchanged, q = value depends on condition, - = unimplemented, r = reserved.
Shaded locations are unimplemented, read as '0'.

Note 1: These registers can be addressed from any bank.
2: Registers in bold have functional differences. Please refer to the appropriate chapters in the data sheet for details.

PIC16F1829LIN

TABLE 4-6: SPECIAL FUNCTION REGISTER SUMMARY (CONTINUED)

Address	Name	Bit 7	Bit 6	Bit 5	Bit 4	Bit 3	Bit 2	Bit 1	Bit 0	Value on POR, BOR	Value on all other Resets	
Banks 9-30												
x00h/ x80h ⁽¹⁾	INDF0	Addressing this location uses contents of FSR0H/FSR0L to address data memory (not a physical register)								xxxx xxxx	xxxx xxxx	
x00h/ x81h ⁽¹⁾	INDF1	Addressing this location uses contents of FSR1H/FSR1L to address data memory (not a physical register)								xxxx xxxx	xxxx xxxx	
x02h/ x82h ⁽¹⁾	PCL	Program Counter (PC) Least Significant Byte								0000 0000	0000 0000	
x03h/ x83h ⁽¹⁾	STATUS	—	—	—	\overline{TO}	\overline{PD}	Z	DC	C	---1 1000	---q quuu	
x04h/ x84h ⁽¹⁾	FSR0L	Indirect Data Memory Address 0 Low Pointer								0000 0000	uuuu uuuu	
x05h/ x85h ⁽¹⁾	FSR0H	Indirect Data Memory Address 0 High Pointer								0000 0000	0000 0000	
x06h/ x86h ⁽¹⁾	FSR1L	Indirect Data Memory Address 1 Low Pointer								0000 0000	uuuu uuuu	
x07h/ x87h ⁽¹⁾	FSR1H	Indirect Data Memory Address 1 High Pointer								0000 0000	0000 0000	
x08h/ x88h ⁽¹⁾	BSR	—	—	—	BSR<4:0>				---	0000	---	0000
x09h/ x89h ⁽¹⁾	WREG	Working Register								0000 0000	uuuu uuuu	
x0Ah/ x8Ah ⁽¹⁾	PCLATH	—	Write Buffer for the upper 7 bits of the Program Counter								-000 0000	-000 0000
x0Bh/ x8Bh ⁽¹⁾	INTCON	GIE	PEIE	TMR0IE	INTE	IOCFIE	TMR0IF	INTF	IOCFIF	0000 0000	0000 0000	
x0Ch/ x8Ch — x1Fh/ x9Fh	—	Unimplemented								—	—	

Legend: x = unknown, u = unchanged, q = value depends on condition, - = unimplemented, r = reserved.
Shaded locations are unimplemented, read as '0'.

Note 1: These registers can be addressed from any bank.

Note 2: Registers in bold have functional differences. Please refer to the appropriate chapters in the data sheet for details.

PIC16F1829LIN

TABLE 4-6: SPECIAL FUNCTION REGISTER SUMMARY (CONTINUED)

Address	Name	Bit 7	Bit 6	Bit 5	Bit 4	Bit 3	Bit 2	Bit 1	Bit 0	Value on POR, BOR	Value on all other Resets	
Bank 31												
F80h ⁽¹⁾	INDF0	Addressing this location uses contents of FSR0H/FSR0L to address data memory (not a physical register)								xxxx xxxx	xxxx xxxx	
F81h ⁽¹⁾	INDF1	Addressing this location uses contents of FSR1H/FSR1L to address data memory (not a physical register)								xxxx xxxx	xxxx xxxx	
F82h ⁽¹⁾	PCL	Program Counter (PC) Least Significant Byte								0000 0000	0000 0000	
F83h ⁽¹⁾	STATUS	—	—	—	\overline{TO}	\overline{PD}	Z	DC	C	---1 1000	---q quuu	
F84h ⁽¹⁾	FSR0L	Indirect Data Memory Address 0 Low Pointer								0000 0000	uuuu uuuu	
F85h ⁽¹⁾	FSR0H	Indirect Data Memory Address 0 High Pointer								0000 0000	0000 0000	
F86h ⁽¹⁾	FSR1L	Indirect Data Memory Address 1 Low Pointer								0000 0000	uuuu uuuu	
F87h ⁽¹⁾	FSR1H	Indirect Data Memory Address 1 High Pointer								0000 0000	0000 0000	
F88h ⁽¹⁾	BSR	—	—	—	BSR<4:0>				---	0000	---	0000
F89h ⁽¹⁾	WREG	Working Register								0000 0000	uuuu uuuu	
F8Ah ⁽¹⁾	PCLATH	—	Write Buffer for the upper 7 bits of the Program Counter								-000 0000	-000 0000
F8Bh ⁽¹⁾	INTCON	GIE	PEIE	TMR0IE	INTE	IOCFIE	TMR0IF	INTF	IOCFIF	0000 0000	0000 0000	
F8Ch — FE3h	—	Unimplemented								—	—	
FE4h	STATUS_SHAD	—	—	—	—	—	Z_SHAD	DC_SHAD	C_SHAD	---- -xxx	---- -uuu	
FE5h	WREG_SHAD	Working Register Shadow								0000 0000	uuuu uuuu	
FE6h	BSR_SHAD	—	—	—	Bank Select Register Shadow				---	xxxx	---	uuuu
FE7h	PCLATH_SHAD	—	Program Counter Latch High Register Shadow								-xxx xxxx	uuuu uuuu
FE8h	FSR0L_SHAD	Indirect Data Memory Address 0 Low Pointer Shadow								xxxx xxxx	uuuu uuuu	
FE9h	FSR0H_SHAD	Indirect Data Memory Address 0 High Pointer Shadow								xxxx xxxx	uuuu uuuu	
FEAh	FSR1L_SHAD	Indirect Data Memory Address 1 Low Pointer Shadow								xxxx xxxx	uuuu uuuu	
FEBh	FSR1H_SHAD	Indirect Data Memory Address 1 High Pointer Shadow								xxxx xxxx	uuuu uuuu	
FECh	—	Unimplemented								—	—	
FEDh	STKPTR	—	—	—	Current Stack pointer				---1 1111	---1 1111		
FEEh	TOSL	Top-of-Stack Low byte								xxxx xxxx	uuuu uuuu	
FEFh	TOSH	—	Top-of-Stack High byte								-xxx xxxx	-uuu uuuu

Legend: x = unknown, u = unchanged, q = value depends on condition, - = unimplemented, r = reserved.
Shaded locations are unimplemented, read as '0'.

Note 1: These registers can be addressed from any bank.

Note 2: Registers in bold have functional differences. Please refer to the appropriate chapters in the data sheet for details.

PIC16F1829LIN

5.0 I/O PORTS

5.1 Alternate Pin Function

The Alternate Pin Function Control 0 (APFCON0) and Alternate Pin Function Control 1 (APFCON1) registers are used to steer specific peripheral input and output functions between different pins. It functions the same as described in the “PIC16(L)F1825/1829 Data Sheet” (DS41440) with the differences described below.

The APFCON0 and APFCON1 registers are shown in [Register 5-1](#) and [Register 5-2](#). For this device family, the following functions can be moved between different pins.

- RX/DT/TX/CK
- T1G
- P1B/P1C/P1D/P2B
- CCP1/P1A/CCP2

These bits have no effect on the values of any TRIS register. PORT and TRIS overrides will be routed to the correct pin. The unselected pin will be unaffected.

Register Definitions: Alternate Pin Function Control

REGISTER 5-1: APFCON0: ALTERNATE PIN FUNCTION CONTROL REGISTER 0

R/W-0/0	R/W-0/0	R/W-0/0	U-0	R/W-0/0	R/W-0/0	U-0	U-0
RXDTSEL	—	—	—	T1GSEL	TXCKSEL	—	—
bit 7							bit 0

Legend:

R = Readable bit

W = Writable bit

U = Unimplemented bit, read as '0'

u = Bit is unchanged

x = Bit is unknown

-n/n = Value at POR and BOR/Value at all other Resets

'1' = Bit is set

'0' = Bit is cleared

- bit 7 **RXDTSEL:** Pin Selection bit
0 = RX/DT function is on RB5
1 = Do not use
- bit 6-4 **Unimplemented:** Read as '0'
- bit 3 **T1GSEL:** Pin Selection bit
0 = T1G function is on RA4
1 = T1G function is on RA3
- bit 2 **TXCKSEL:** Pin Selection bit
0 = TX/CK function is on RB7
1 = TX/CK function is on RC4
- bit 1-0 **Unimplemented:** Read as '0'

REGISTER 5-2: APFCON1: ALTERNATE PIN FUNCTION CONTROL REGISTER 1

U-0	U-0	R/W-0/0	R/W-0/0	R/W-0/0	R/W-0/0	R/W-0/0	R/W-0/0
—	—	—	—	P1DSEL	P1CSEL	P2BSEL	CCP2SEL
bit 7						bit 0	

Legend:

R = Readable bit

W = Writable bit

U = Unimplemented bit, read as '0'

u = Bit is unchanged

x = Bit is unknown

-n/n = Value at POR and BOR/Value at all other Resets

'1' = Bit is set

'0' = Bit is cleared

bit 7-4 **Unimplemented:** Read as '0'

bit 3 **P1DSEL:** Pin Selection bit
 0 = P1D function is on RC2
 1 = P1D function is on RC0

bit 2 **P1CSEL:** Pin Selection bit
 0 = P1C function is on RC3
 1 = P1C function is on RC1

bit 1 **P2BSEL:** Pin Selection bit
 0 = P2B function is on RC2
 1 = P2B function is on RA4

bit 0 **CCP2SEL:** Pin Selection bit
 0 = CCP2 function is on RC3
 1 = CCP2 function is on RA5

PIC16F1829LIN

5.2 PORTB Registers

PORTB is a 4-bit wide, bidirectional port. It functions the same as described in the “PIC16(L)F1825/1829 Data Sheet” (DS41440) with the following differences:

- Three bits are dedicated to the LIN transceiver. No pins are associated with this function. Only RB4 is available on a pin. The corresponding data direction register is TRISB. The TRISB bits must be set as ‘001x 0000’.
- The PORTB Data Latch register (LATB) is also memory-mapped. Read-modify-write operations on the LATB register read and write the latched output value for PORTB.

EXAMPLE 5-1: INITIALIZING PORTB

```
banksel PORTB
MOVLW  0C0h   ; set LINCS and LINTX
           ; high
MOVWF  PORTB  ; Initialize PORTB by
           ; clearing output
           ; data latches

banksel LATB
CLRF   LATB   ; Alternate method
           ; to clear output
           ; data latches

banksel TRISB
MOVLW  030h   ; Value used to
           ; initialize data
           ; direction
MOVWF  TRISB  ; Set RB<7:6> as outputs
           ; and RB<5:4> as inputs
```

Note: On a Power-on Reset, RB<5:4> are configured as analog inputs by default and read as ‘0’.

5.2.1 ANSELB REGISTER

The ANSELB register ([Register 5-6](#)) is used to configure the Input mode of an I/O pin to analog. Setting the appropriate ANSELB bit high will cause all digital reads on the pin to be read as ‘0’ and allow analog functions on the pin to operate correctly.

The state of the ANSELB bits has no effect on digital output functions. A pin with TRIS clear and ANSELB set will still operate as a digital output, but the Input mode will be analog. This can cause unexpected behavior when executing READ-MODIFY-WRITE instructions on the affected port.

Note: The ANSELB bits default to the Analog mode after Reset. To use any pins as digital general purpose or peripheral inputs, the corresponding ANSEL bits must be initialized to ‘0’ by user software.

REGISTER 5-3: PORTB: PORTB REGISTER

R/W-x	R/W-x	R/W-x	R/W-x	U-0	U-0	U-0	U-0
LINTX	LINCS	LINRX	RB4	—	—	—	—
bit 7							bit 0

Legend:

R = Readable bit	W = Writable bit	U = Unimplemented bit, read as '0'
-n = Value at POR	'1' = Bit is set	'0' = Bit is cleared
		x = Bit is unknown

bit 7 **LINTX:** Dedicated the LIN Transceiver Transmit Function
bit 6 **LINCS:** Dedicated the LIN Transceiver Chip Select Function
bit 5 **LINRX:** Dedicated the LIN Transceiver Receive Function
bit 4 **RB4:** Port I/O pin bit
bit 3-0 **Unimplemented:** Read as '0'

REGISTER 5-4: TRISB: PORTB TRI-STATE REGISTER

R/W-1/1	R/W-1/1	R/W-1/1	R/W-1/1	U-0	U-0	U-0	U-0
TRISB7	TRISB6	TRISB5	TRISB4	—	—	—	—
bit 7							bit 0

Legend:

R = Readable bit	W = Writable bit	U = Unimplemented bit, read as '0'
u = Bit is unchanged	x = Bit is unknown	-n/n = Value at POR and BOR/Value at all other Resets
'1' = Bit is set	'0' = Bit is cleared	

bit 7 **TRISB7:** Must be set to '0', Dedicated the LIN Transceiver Transmit Function
bit 6 **TRISB6:** Must be set to '0', Dedicated the LIN Transceiver Chip Select Function
bit 5 **TRISB5:** Must be set to '1', Dedicated the LIN Transceiver Receive Function
bit 4 **TRISB4:** PORTB4 Tri-State Control bits
 1 = PORTB pin configured as an input (tri-stated)
 0 = PORTB pin configured as an output
bit 3-0 **Unimplemented:** Read as '0'

PIC16F1829LIN

REGISTER 5-5: LATB: PORTB DATA LATCH REGISTER

R/W-x/u	R/W-x/u	R/W-x/u	R/W-x/u	U-0	U-0	U-0	U-0
LATB7	LATB6	LATB5	LATB4	—	—	—	—
bit 7							bit 0

Legend:

R = Readable bit W = Writable bit U = Unimplemented bit, read as '0'
u = Bit is unchanged x = Bit is unknown -n/n = Value at POR and BOR/Value at all other Resets
'1' = Bit is set '0' = Bit is cleared

bit 7-5 **LATB<7:5>**: Dedicated the LIN Transceiver Transmit Function⁽¹⁾

bit 4 **LATB4**: RB4 Port I/O Output Latch Register bit⁽¹⁾

bit 3-0 **Unimplemented**: Read as '0'

Note 1: Writes to PORTB are actually written to the corresponding LATB register. Reads from the PORTB register actually return the I/O pin values.

REGISTER 5-6: ANSELB: PORTB ANALOG SELECT REGISTER

R/W-1/1	R/W-1/1	R/W-1/1	R/W-1/1	U-0	U-0	U-0	U-0
ANSB7	ANSB6	ANSB5	ANSB4	—	—	—	—
bit 7							bit 0

Legend:

R = Readable bit W = Writable bit U = Unimplemented bit, read as '0'
u = Bit is unchanged x = Bit is unknown -n/n = Value at POR and BOR/Value at all other Resets
'1' = Bit is set '0' = Bit is cleared

bit 7-5 **ANSB<7:5>**: Analog Select between Analog or Digital Function on Pins RB<7:5>
0 = Must be set to '0'. Digital I/O. Pin is assigned to port or digital special function.
1 = Not used

bit 4 **ANSB4**: Analog Select between Analog or Digital Function on Pin RB4
0 = Digital I/O. Pin is assigned to port or digital special function.
1 = Analog input. Pin is assigned as analog input⁽¹⁾. Digital input buffer is disabled.

bit 3-0 **Unimplemented**: Read as '0'

Note 1: When setting a pin to an analog input, the corresponding TRIS bit must be set to Input mode in order to allow external control of the voltage on the pin.

REGISTER 5-7: WPUB: WEAK PULL-UP PORTB REGISTER

R/W-1/1	R/W-1/1	R/W-1/1	R/W-1/1	U-0	U-0	U-0	U-0
WPUB7	WPUB6	WPUB5	WPUB4	—	—	—	—
bit 7							bit 0

Legend:

R = Readable bit W = Writable bit U = Unimplemented bit, read as '0'
u = Bit is unchanged x = Bit is unknown -n/n = Value at POR and BOR/Value at all other Resets
'1' = Bit is set '0' = Bit is cleared

bit 7-4 **WPUB<7:4>**: Weak Pull-up Register bits
1 = Pull-up enabled
0 = Pull-up disabled

bit 3-0 **Unimplemented**: Read as '0'

- Note 1:** Global **WPUEN** bit of the **OPTION_REG** register must be cleared for individual pull-ups to be enabled.
Note 2: The weak pull-up device is automatically disabled if the pin is configured as an output.

REGISTER 5-8: INLVLB: PORTB INPUT LEVEL CONTROL REGISTER

R/W-0/0	R/W-0/0	R/W-0/0	R/W-0/0	U-0	U-0	U-0	U-0
INLVLB7	INLVLB6	INLVLB5	INLVLB4	—	—	—	—
bit 7							bit 0

Legend:

R = Readable bit W = Writable bit U = Unimplemented bit, read as '0'
u = Bit is unchanged x = Bit is unknown -n/n = Value at POR and BOR/Value at all other Resets
'1' = Bit is set '0' = Bit is cleared

bit 7-4 **INLVLB<7:4>**: PORTB Input Level Select bits
For RB<7:4> pins, respectively
1 = ST input used for PORT reads and Interrupt-on-Change
0 = TTL input used for PORT reads and Interrupt-on-Change

bit 3-0 **Unimplemented**: Read as '0'

TABLE 5-1: SUMMARY OF REGISTERS ASSOCIATED WITH PORTB

Name	Bit 7	Bit 6	Bit 5	Bit 4	Bit 3	Bit 2	Bit 1	Bit 0	Register on Page
ANSELB	ANSB7	ANSB6	ANSB5	ANSB4	—	—	—	—	42
INLVLB	INLVLB7	INLVLB6	INLVLB5	INLVLB4	—	—	—	—	43
LATB	LATB7	LATB6	LATB5	LATB4	—	—	—	—	42
PORTB	LINTX	LINCS	LINRX	RB4	—	—	—	—	41
TRISB	TRISB7	TRISB6	TRISB5	TRISB4	—	—	—	—	41
WPUB	WPUB7	WPUB6	WPUB5	WPUB4	—	—	—	—	43

Legend: x = unknown, u = unchanged, - = unimplemented locations read as '0'. Shaded cells are not used by PORTB.

PIC16F1829LIN

5.3 PORTC Registers

PORTC is an 8-bit wide, bidirectional port. It functions the same as described in the “PIC16(L)F1825/1829 Data Sheet” (DS41440) with the following differences:

- One bit is dedicated to the LIN transceiver and one bit is not available. No pins are associated with this function. Only RC<5:0> are available on pins. The corresponding data direction register is TRISC. The TRISC bits must be set as ‘1xxx xxxx’.
- The PORTC Data Latch register (LATC) is also memory mapped. Read-modify-write operations on the LATC register read and write the latched output value for PORTC.

Note: On a Power-on Reset, RC<7:6> and RC<3:0> are configured as analog inputs and read as ‘0’.

EXAMPLE 5-2: INITIALIZING PORTC

```
banksel PORTC
CLRF   PORTC   ; Initialize PORTC by
                ; clearing output
                ; data latches

banksel LATC
CLRF   LATC    ; Alternate method
                ; to clear output
                ; data latches

banksel TRISC
MOVLW  0FFh   ; Value used to
                ; initialize data
                ; direction
```

5.3.1 ANSELC REGISTER

The ANSELC register (Register 5-12) is used to configure the Input mode of an I/O pin to analog. Setting the appropriate ANSELC bit high will cause all digital reads on the pin to be read as ‘0’ and allow analog functions on the pin to operate correctly.

The state of the ANSELC bits has no effect on digital output functions. A pin with TRIS clear and ANSELC set will still operate as a digital output, but the Input mode will be analog. This can cause unexpected behavior when executing READ-MODIFY-WRITE instructions on the affected port.

Note: The ANSELC bits default to the Analog mode after Reset. To use any pins as digital general purpose or peripheral inputs, the corresponding ANSEL bits must be initialized to ‘0’ by user software.

5.3.2 PORTC FUNCTIONS AND OUTPUT PRIORITIES

Each PORTC pin is multiplexed with other functions. The pins, their combined functions and their output priorities are briefly described here. For additional information, please refer to Table 1-1 and Table 1-2.

When multiple outputs are enabled, the actual pin control goes to the peripheral with the lowest number in the following lists.

Analog input and some digital input functions are not included in the list below (see Table 5-2). These input functions can remain active when the pin is configured as an output. Certain digital input functions override other port functions and are included in the priority list.

TABLE 5-2: PORTC OUTPUT PRIORITY

Pin Name	Function Priority ⁽¹⁾
RC0	P1D ⁽²⁾
RC1	P1C ⁽²⁾
RC2	P1D ⁽²⁾ P2B ⁽²⁾
RC3	CCP2 ⁽²⁾ P1C ⁽²⁾ P2A ⁽²⁾
RC4	MDOUT SRNQ C2OUT P1B
RC5	CCP1/P1A
RC6 ⁽³⁾	Not available
RC7 ⁽³⁾	PWRGD

- Note**
- 1: Priority listed from highest to lowest.
 - 2: Pin function is selectable via the APFCON0 or APFCON1 register.
 - 3: RC6 is not available to a pin. RC7 is internally connected to the PWRGD signal from the LIN transceiver.

REGISTER 5-9: PORTC: PORTC REGISTER

R/W-x/u	R/W-x/u	R/W-x/u	R/W-x/u	R/W-x/u	R/W-x/u	R/W-x/u	R/W-x/u
PWRGD	—	RC5	RC4	RC3	RC2	RC1	RC0
bit 7							bit 0

Legend:

R = Readable bit	W = Writable bit	U = Unimplemented bit, read as '0'
u = Bit is unchanged	x = Bit is unknown	-n/n = Value at POR and BOR/Value at all other Resets
'1' = Bit is set	'0' = Bit is cleared	

bit 7 **PWRGD**: Power Good Signal from Voltage Regulator
 1 = Voltage Regulator is stable and within operating limits
 0 = Voltage Regulator is not stable

bit 6 **No Function**

bit 5-0 **RC<5:0>**: PORTC General Purpose I/O Pin bits
 1 = Port pin is $\geq V_{IH}$
 0 = Port pin is $\leq V_{IL}$

REGISTER 5-10: TRISC: PORTC TRI-STATE REGISTER

R/W-1/1	R/W-1/1	R/W-1/1	R/W-1/1	R/W-1/1	R/W-1/1	R/W-1/1	R/W-1/1
TRISC7	—	TRISC5	TRISC4	TRISC3	TRISC2	TRISC1	TRISC0
bit 7							bit 0

Legend:

R = Readable bit	W = Writable bit	U = Unimplemented bit, read as '0'
u = Bit is unchanged	x = Bit is unknown	-n/n = Value at POR and BOR/Value at all other Resets
'1' = Bit is set	'0' = Bit is cleared	

bit 7 **TRISC7**: PORTC Tri-State Control bit
 1 = PORTC pin configured as PWRGD input (tri-stated)
 0 = Do not use to avoid internal contention

bit 6 **Don't Care**

bit 5-0 **TRISC<5:0>**: PORTC Tri-State Control bits
 1 = PORTC pin configured as an input (tri-stated)
 0 = PORTC pin configured as an output

PIC16F1829LIN

REGISTER 5-11: LATC: PORTC DATA LATCH REGISTER

R/W-x/u	R/W-x/u	R/W-x/u	R/W-x/u	R/W-x/u	R/W-x/u	R/W-x/u	R/W-x/u
PWRGD	—	LATC5	LATC4	LATC3	LATC2	LATC1	LATC0
bit 7							bit 0

Legend:

R = Readable bit W = Writable bit U = Unimplemented bit, read as '0'
u = Bit is unchanged x = Bit is unknown -n/n = Value at POR and BOR/Value at all other Resets
'1' = Bit is set '0' = Bit is cleared

bit 7 **PWRGD**: Configured as an Input Value; Don't Care

bit 6 **Don't Care**

bit 5-0 **LATC<7:0>**: PORTC Output Latch Value bits⁽¹⁾

Note 1: Writes to PORTC are actually written to corresponding LATC register. Reads from PORTC register is return of actual I/O pin values.

REGISTER 5-12: ANSELC: PORTC ANALOG SELECT REGISTER

R/W-1/1	R/W-1/1	U-0	U-0	R/W-1/1	R/W-1/1	R/W-1/1	R/W-1/1
ANSC7	—	—	—	ANSC3	ANSC2	ANSC1	ANSC0
bit 7							bit 0

Legend:

R = Readable bit W = Writable bit U = Unimplemented bit, read as '0'
u = Bit is unchanged x = Bit is unknown -n/n = Value at POR and BOR/Value at all other Resets
'1' = Bit is set '0' = Bit is cleared

bit 7 **ANSC7**: Analog Select between Analog or Digital Function on Pin RC7

0 = Set for PWRGD input
1 = Do not use

bit 6-4 **Unimplemented**: Read as '0'

bit 3-0 **ANSC<3:0>**: Analog Select between Analog or Digital Function on Pins RC<3:0>

0 = Digital I/O. Pin is assigned to port or digital special function.
1 = Analog input. Pin is assigned as analog input⁽¹⁾. Digital input buffer disabled.

Note 1: When setting a pin to an analog input, the corresponding TRIS bit must be set to Input mode in order to allow external control of the voltage on the pin.

REGISTER 5-13: WPUC: WEAK PULL-UP PORTC REGISTER

R/W-1/1	R/W-1/1	R/W-1/1	R/W-1/1	R/W-1/1	R/W-1/1	R/W-1/1	R/W-1/1
WPUC7	WPUC6	WPUC5	WPUC4	WPUC3	WPUC2	WPUC1	WPUC0
bit 7							bit 0

Legend:

R = Readable bit W = Writable bit U = Unimplemented bit, read as '0'
u = Bit is unchanged x = Bit is unknown -n/n = Value at POR and BOR/Value at all other Resets
'1' = Bit is set '0' = Bit is cleared

bit 7-0 **WPUC<7:0>**: Weak Pull-up Register bits^(1, 2)
1 = Pull-up enabled
0 = Pull-up disabled

- Note 1:** Global WPUEN bit of the OPTION_REG register must be cleared for individual pull-ups to be enabled.
2: The weak pull-up device is automatically disabled if the pin is configured as an output.

REGISTER 5-14: INLVLC: PORTC INPUT LEVEL CONTROL REGISTER

R/W-0/0	R/W-0/0	R/W-0/0	R/W-0/0	R/W-0/0	R/W-1/1	R/W-0/0	R/W-0/0
INLVLC7	INLVLC6	INLVLC5	INLVLC4	INLVLC3	INLVLC2	INLVLC1	INLVLC0
bit 7							bit 0

Legend:

R = Readable bit W = Writable bit U = Unimplemented bit, read as '0'
u = Bit is unchanged x = Bit is unknown -n/n = Value at POR and BOR/Value at all other Resets
'1' = Bit is set '0' = Bit is cleared

bit 7-0 **INLVLC<7:0>**: PORTC Input Level Select bits
For RC<7:0> pins:
1 = ST input used for port reads and Interrupt-on-change
0 = TTL input used for port reads and Interrupt-on-change

TABLE 5-3: SUMMARY OF REGISTERS ASSOCIATED WITH PORTC

Name	Bit 7	Bit 6	Bit 5	Bit 4	Bit 3	Bit 2	Bit 1	Bit 0	Register on Page
ANSEL	ANSEL7	—	—	—	ANSEL3	ANSEL2	ANSEL1	ANSEL0	46
INLVLC	INLVLC7	INLVLC6	INLVLC5	INLVLC4	INLVLC3	INLVLC2	INLVLC1	INLVLC0	47
LATC	PWRGD	—	LATC5	LATC4	LATC3	LATC2	LATC1	LATC0	46
PORTC	PWRGD	—	RC5	RC4	RC3	RC2	RC1	RC0	45
TRISC	TRISC7	—	TRISC5	TRISC4	TRISC3	TRISC2	TRISC1	TRISC0	45
WPUC	WPUC7	WPUC6	WPUC5	WPUC4	WPUC3	WPUC2	WPUC1	WPUC0	47

Legend: x = unknown, u = unchanged, - = unimplemented locations read as '0'. Shaded cells are not used by PORTC.

PIC16F1829LIN

6.0 ANALOG-TO-DIGITAL CONVERTER (ADC) MODULE

The Analog-to-Digital Converter (ADC) allows conversion of an analog input signal to a 10-bit binary representation of that signal. It functions the same as described in the "PIC16(L)F1825/1829 Data Sheet" (DS41440) with the differences shown in Figure 6-1.

FIGURE 6-1: ADC BLOCK DIAGRAM

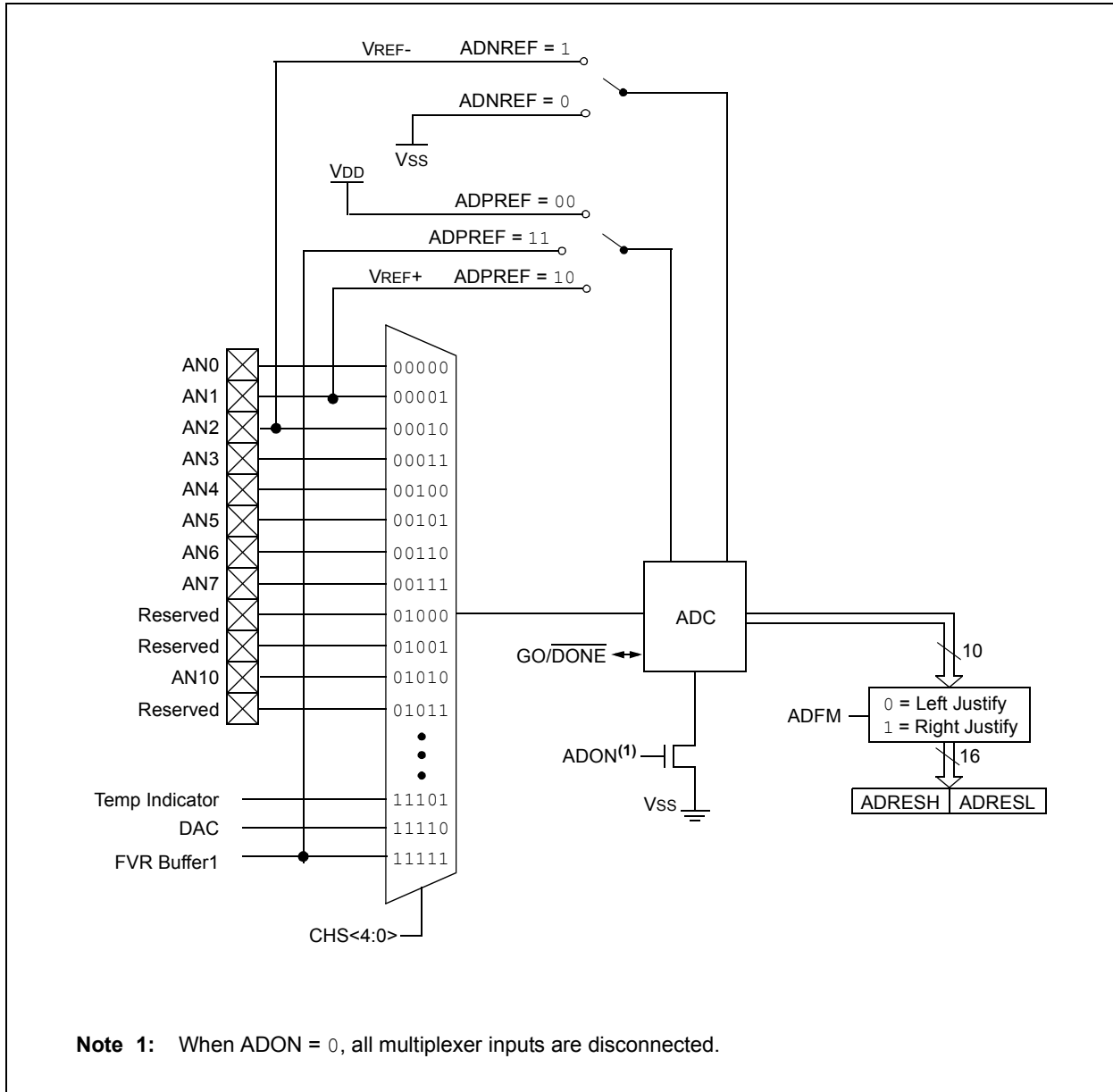

6.1 ADC Register Definitions

The following registers are used to control the operation of the ADC.

Register Definitions: ADC Control

REGISTER 6-1: ADCON0: A/D CONTROL REGISTER 0

U-0	R/W-0/0	R/W-0/0	R/W-0/0	R/W-0/0	R/W-0/0	R/W-0/0	R/W-0/0
—	CHS<4:0>					GO/DONE	ADON
bit 7							bit 0

Legend:

R = Readable bit	W = Writable bit	U = Unimplemented bit, read as '0'
u = Bit is unchanged	x = Bit is unknown	-n/n = Value at POR and BOR/Value at all other Resets
'1' = Bit is set	'0' = Bit is cleared	

bit 7 **Unimplemented:** Read as '0'

bit 6-2 **CHS<4:0>:** Analog Channel Select bits

- 00000 = AN0
- 00001 = AN1
- 00010 = AN2
- 00011 = AN3
- 00100 = AN4
- 00101 = AN5
- 00110 = AN6
- 00111 = AN7
- 01000 = Reserved
- 01001 = Reserved
- 01010 = AN10
- 01011 = Reserved
- 01100 = Reserved. No channel connected.
-
-
-
- 11100 = Reserved. No channel connected.
- 11101 = Temperature Indicator⁽³⁾
- 11110 = DAC output⁽¹⁾
- 11111 = FVR (Fixed Voltage Reference) Buffer 1 Output⁽²⁾

bit 1 **GO/DONE:** A/D Conversion Status bit

- 1 = A/D conversion cycle in progress. Setting this bit starts an A/D conversion cycle. This bit is automatically cleared by hardware when the A/D conversion has completed.
- 0 = A/D conversion completed/not in progress

bit 0 **ADON:** ADC Enable bit

- 1 = ADC is enabled
- 0 = ADC is disabled and consumes no operating current

- Note 1:** See **Section 17.0 “Digital-to-Analog Converter (DAC) Module”** of the “PIC16(L)F1825/1829 Data Sheet” (DS41440) for more information.
- 2:** See **Section 14.0 “Fixed Voltage Reference (FVR)”** of the “PIC16(L)F1825/1829 Data Sheet” (DS41440) for more information.
- 3:** See **Section 15.0 “Temperature Indicator Module”** of the “PIC16(L)F1825/1829 Data Sheet” (DS41440) for more information.

PIC16F1829LIN

TABLE 6-1: SUMMARY OF REGISTERS ASSOCIATED WITH ADC

Name	Bit 7	Bit 6	Bit 5	Bit 4	Bit 3	Bit 2	Bit 1	Bit 0	Register on Page
ADCON0	—	CHS<4:0>					GO/DONE	ADON	49
ADCON1	ADFM	ADCS<2:0>			—	ADNREF	ADPREF<1:0>		—
ADRESH	A/D Result Register High								—
ADRESL	A/D Result Register Low								—
ANSELA	—	—	—	ANSA4	—	ANSA2	ANSA1	ANSA0	—
ANSELB ⁽¹⁾	ANSB7	ANSB6	ANSB5	ANSB4	—	—	—	—	42
ANSELC	ANSC7	—	—	—	ANSC3	ANSC2	ANSC1	ANSC0	46
CCP4CON	P4M1	P4M0	DC4B1	DC4B0	CCP4M3	CCP4M2	CCP4M1	CCP4M0	—
INLVLA	—	—	INLVLA5	INLVLA4	INLVLA3	INLVLA2	INLVLA1	INLVLA0	—
INVLVB ⁽¹⁾	INVLVB7	INVLVB6	INVLVB5	INVLVB4	—	—	—	—	43
INLVLC	INLVLC7 ⁽¹⁾	INLVLC6 ⁽¹⁾	INLVLC5	INLVLC4	INLVLC3	INLVLC2	INLVLC1	INLVLC0	47
INTCON	GIE	PEIE	TMR0IE	INTE	IOCIE	TMR0IF	INTF	IOCIF	—
PIE1	TMR1GIE	ADIE	RCIE	TXIE	SSP1IE	CCP1IE	TMR2IE	TMR1IE	—
PIR1	TMR1GIF	ADIF	RCIF	TXIF	SSP1IF	CCP1IF	TMR2IF	TMR1IF	—
TRISA	—	—	TRISA5	TRISA4	TRISA3	TRISA2	TRISA1	TRISA0	—
TRISB ⁽¹⁾	TRISB7	TRISB6	TRISB5	TRISB4	—	—	—	—	41
TRISC	TRISC7 ⁽¹⁾	TRISC6 ⁽¹⁾	TRISC5	TRISC4	TRISC3	TRISC2	TRISC1	TRISC0	45
FVRCON	FVREN	FVRRDY	TSEN	TSRNG	CDAFVR<1:0>		ADFVR<1:0>		—
DACCON0	DACEN	DACLPS	DACOE	—	DACPSS<1:0>		—	DACNSS	—
DACCON1	—	—	—	DACR<4:0>					—

Legend: x = unknown, u = unchanged, — = unimplemented read as '0', q = value depends on condition. Shaded cells are not used for ADC module.

Note 1: TRISC6 is not used as the signal does not come out to a pin. TRISC7 must be set to '1'. TRISB bits should be set as described in [Register 5-4](#).

7.0 MASTER SYNCHRONOUS SERIAL PORT (MSSP1 AND MSSP2) MODULE

7.1 Master SSPx (MSSPx) Module Overview

The Master Synchronous Serial Port (MSSPx) module is not to be used as its operation conflicts with LIN pin functions.

TABLE 7-1: SUMMARY OF REGISTERS ASSOCIATED WITH MSSP OPERATION

Name	Bit 7	Bit 6	Bit 5	Bit 4	Bit 3	Bit 2	Bit 1	Bit 0	Register on Page
ANSELA	—	—	—	ANSA4	—	ANSA2	ANSA1	ANSA0	—
ANSELB	ANSB7	ANSB6	ANSB5	ANSB4	—	—	—	—	42
ANSELC	ANSC7	—	—	—	ANSC3	ANSC2	ANSC1	ANSC0	46
APFCON0	RXDTSEL	—	—	—	T1GSEL	TXCKSEL	—	—	38
APFCON1	—	—	—	—	P1DSEL	P1CSEL	P2BSEL	CCP2SEL	39
INLVLA	—	—	INLVLA5	INLVLA4	INLVLA3	INLVLA2	INLVLA1	INLVLA0	—
INVLVB	INVLVB7	INVLVB6	INVLVB5	INVLVB4	—	—	—	—	43
INLVLC	INLVLC7	INLVLC6	INLVLC5	INLVLC4	INLVLC3	INLVLC2	INLVLC1	INLVLC0	47
INTCON	GIE	PEIE	TMR0IE	INTE	IOCFIE	TMR0IF	INTF	IOCFIF	—
PIE1	TMR1GIE	ADIE	RCIE	TXIE	SSP1IE	CCP1IE	TMR2IE	TMR1IE	—
PIR1	TMR1GIF	ADIF	RCIF	TXIF	SSP1IF	CCP1IF	TMR2IF	TMR1IF	—
SSP1BUF	Don't care								—
SSP1CON1	0	0	0	0	0	0	0	0	—
SSP1CON3	0	0	0	0	0	0	0	0	—
SSP1STAT	0	0	0	0	0	0	0	0	—
TRISA	—	—	TRISA5	TRISA4	TRISA3	TRISA2	TRISA1	TRISA0	—
TRISB	TRISB7	TRISB6	TRISB5	TRISB4	—	—	—	—	41
TRISC	TRISC7	TRISC6	TRISC5	TRISC4	TRISC3	TRISC2	TRISC1	TRISC0	45

Legend: — = Unimplemented location, read as '0'. Shaded cells are not used by the MSSP1 in SPI mode.

PIC16F1829LIN

8.0 ENHANCED UNIVERSAL SYNCHRONOUS ASYNCHRONOUS RECEIVER TRANSMITTER (EUSART)

The Enhanced Universal Synchronous Asynchronous Receiver Transmitter (EUSART) module is a serial I/O communications peripheral. It functions the same as described in the “PIC16(L)F1825/1829 Data Sheet” (DS41440) with the following differences:

- The 9-bit character length and Address detection should not be used.
- Programmable clock and data polarity should not be used.

8.1 Asynchronous Transmission Setup

1. Initialize the SPBRGH, SPBRGL register pair and the BRGH and BRG16 bits to achieve the desired baud rate (see **Section 26.3, EUSART Baud Rate Generator (BRG)** in the “PIC16(L)F1825/1829 Data Sheet” (DS41440)).
2. Enable the asynchronous serial port by clearing the SYNC bit and setting the SPEN bit.
3. TX9 control bit should always be ‘0’ for LIN transmission.
4. Set the SCKP bit if inverted transmit is desired.
5. Enable the transmission by setting the TXEN control bit. This will cause the TXIF interrupt bit to be set.
6. If interrupts are desired, set the TXIE interrupt enable bit of the PIE1 register. An interrupt will occur immediately, provided that the GIE and PEIE bits of the INTCON register are also set.
7. If 9-bit transmission is selected, the ninth bit should be loaded into the TX9D data bit.
8. Load 8-bit data into the TXREG register. This will start the transmission.

TABLE 8-1: SUMMARY OF REGISTERS ASSOCIATED WITH ASYNCHRONOUS TRANSMISSION

Name	Bit 7	Bit 6	Bit 5	Bit 4	Bit 3	Bit 2	Bit 1	Bit 0	Register on Page
APFCON0	RXDTSEL	—	—	—	T1GSEL	TXCKSEL	—	—	38
BAUDCON	ABDOVF	RCIDL	—	SCKP	BRG16	—	WUE	ABDEN	56
INLVLA	—	—	INLVLA5	INLVLA4	INLVLA3	INLVLA2	INLVLA1	INLVLA0	—
INVLVB	INVLVB7	INVLVB6	INVLVB5	INVLVB4	—	—	—	—	43
INLVLC	INLVLC7	INLVLC6	INLVLC5	INLVLC4	INLVLC3	INLVLC2	INLVLC1	INLVLC0	47
INTCON	GIE	PEIE	TMR0IE	INTE	IOCF	TMR0IF	INTF	IOCF	—
PIE1	TMR1GIE	ADIE	RCIE	TXIE	SSP1IE	CCP1IE	TMR2IE	TMR1IE	—
PIR1	TMR1GIF	ADIF	RCIF	TXIF	SSP1IF	CCP1IF	TMR2IF	TMR1IF	—
RCSTA	SPEN	RX9	SREN	CREN	ADDEN	FERR	OERR	RX9D	55
SPBRGL	BRG<7:0>								52*
SPBRGH	BRG<15:8>								52*
TRISA	—	—	TRISA5	TRISA4	TRISA3	TRISA2	TRISA1	TRISA0	—
TRISB	TRISB7	TRISB6	TRISB5	TRISB4	—	—	—	—	41
TRISC	TRISC7	TRISC6	TRISC5	TRISC4	TRISC3	TRISC2	TRISC1	TRISC0	45
TXREG	EUSART Transmit Data Register								52*
TXSTA	CSRC	TX9	TXEN	SYNC	SENDB	BRGH	TRMT	TX9D	54

Legend: — = unimplemented location, read as ‘0’. Shaded cells are not used for Asynchronous Transmission.

* Page provides register information.

8.2 Asynchronous Reception Setup

1. Initialize the SPBRGH, SPBRGL register pair and the BRGH and BRG16 bits to achieve the desired baud rate (see **Section 26.3, EUSART Baud Rate Generator (BRG)** in the “PIC16(L)F1825/1829 Data Sheet” (DS41440)).
2. Clear the ANSEL bit for the RX pin (if applicable).
3. Enable the serial port by setting the SPEN bit. The SYNC bit must be clear for asynchronous operation.
4. If interrupts are desired, set the RCIE bit of the PIE1 register and the GIE and PEIE bits of the INTCON register.
5. If 9-bit reception is desired, set the RX9 bit.
6. Enable reception by setting the CREN bit.
7. The RCIF interrupt flag bit will be set when a character is transferred from the RSR to the receive buffer. An interrupt will be generated if the RCIE interrupt enable bit was also set.
8. Read the RCSTA register to get the error flags and, if 9-bit data reception is enabled, the ninth data bit.
9. Get the received eight Least Significant data bits from the receive buffer by reading the RCREG register.
10. If an overrun occurred, clear the OERR flag by clearing the CREN receiver enable bit.

TABLE 8-2: SUMMARY OF REGISTERS ASSOCIATED WITH ASYNCHRONOUS RECEPTION

Name	Bit 7	Bit 6	Bit 5	Bit 4	Bit 3	Bit 2	Bit 1	Bit 0	Register on Page
APFCON0	RXDTSEL	—	—	—	T1GSEL	TXCKSEL	—	—	38
BAUDCON	ABDOVF	RCIDL	—	SCKP	BRG16	—	WUE	ABDEN	56
INLVLA	—	—	INLVLA5	INLVLA4	INLVLA3	INLVLA2	INLVLA1	INLVLA0	—
INVLVB	INVLVB7	INVLVB6	INVLVB5	INVLVB4	—	—	—	—	43
INLVLC	INLVLC7	INLVLC6	INLVLC5	INLVLC4	INLVLC3	INLVLC2	INLVLC1	INLVLC0	47
INTCON	GIE	PEIE	TMR0IE	INTE	IOCIE	TMR0IF	INTF	IOCIF	—
PIE1	TMR1GIE	ADIE	RCIE	TXIE	SSP1IE	CCP1IE	TMR2IE	TMR1IE	—
PIR1	TMR1GIF	ADIF	RCIF	TXIF	SSP1IF	CCP1IF	TMR2IF	TMR1IF	—
RCREG	EUSART Receive Data Register								53*
RCSTA	SPEN	RX9	SREN	CREN	ADDEN	FERR	OERR	RX9D	55
SPBRGL	BRG<7:0>								52, 53*
SPBRGH	BRG<15:8>								52, 53*
TRISA	—	—	TRISA5	TRISA4	TRISA3	TRISA2	TRISA1	TRISA0	—
TRISB	TRISB7	TRISB6	TRISB5	TRISB4	—	—	—	—	41
TRISC	TRISC7	TRISC6	TRISC5	TRISC4	TRISC3	TRISC2	TRISC1	TRISC0	45
TXSTA	CSRC	TX9	TXEN	SYNC	SENDB	BRGH	TRMT	TX9D	54

Legend: — = unimplemented location, read as ‘0’. Shaded cells are not used for Asynchronous Reception.

* Page provides register information.

PIC16F1829LIN

REGISTER 8-1: TXSTA: TRANSMIT STATUS AND CONTROL REGISTER

R/W-/0	R/W-0/0	R/W-0/0	R/W-0/0	R/W-0/0	R/W-0/0	R-1/1	R/W-0/0
CSRC	TX9	TXEN	SYNC	SENDB	BRGH	TRMT	TX9D
bit 7							bit 0

Legend:

R = Readable bit

W = Writable bit

U = Unimplemented bit, read as '0'

u = Bit is unchanged

x = Bit is unknown

-n/n = Value at POR and BOR/Value at all other Resets

'1' = Bit is set

'0' = Bit is cleared

bit 7 **CSRC:** Must be '0'

bit 6 **TX9:** Must be '0'

bit 5 **TXEN:** Transmit Enable bit

1 = Transmit enabled

0 = Transmit disabled

bit 4 **SYNC:** Must be '0'

bit 3 **SENDB:** Send BREAK Character bit

1 = Send Sync Break on next transmission (cleared by hardware upon completion)

0 = Sync Break transmission completed

bit 2 **BRGH:** High Baud Rate Select bit

1 = High speed

0 = Low speed

bit 1 **TRMT:** Transmit Shift Register Status bit

1 = TSR empty

0 = TSR full

bit 0 **TX9D:** Must be '0'

REGISTER 8-2: RCSTA: RECEIVE STATUS AND CONTROL REGISTER

R/W-0/0	R/W-0/0	R/W-0/0	R/W-0/0	R/W-0/0	R-0/0	R-0/0	R-x/x
SPEN	RX9	SREN	CREN	ADDEN	FERR	OERR	RX9D
bit 7							bit 0

Legend:

R = Readable bit	W = Writable bit	U = Unimplemented bit, read as '0'
u = Bit is unchanged	x = Bit is unknown	-n/n = Value at POR and BOR/Value at all other Resets
'1' = Bit is set	'0' = Bit is cleared	

bit 7	SPEN: Serial Port Enable bit 1 = Serial port enabled (configures RX/DT and TX/CK pins as serial port pins) 0 = Serial port disabled (held in Reset)
bit 6	RX9: Must be '0'
bit 5	SREN: Don't Care
bit 4	CREN: Continuous Receive Enable bit 1 = Enables receiver 0 = Disables receiver
bit 3	ADDEN: Must be '0'
bit 2	FERR: Framing Error bit 1 = Framing error (can be updated by reading RCREG register and receive next valid byte) 0 = No framing error
bit 1	OERR: Overrun Error bit 1 = Overrun error (can be cleared by clearing bit CREN) 0 = No overrun error
bit 0	RX9D: Must be '0'

PIC16F1829LIN

REGISTER 8-3: BAUDCON: BAUD RATE CONTROL REGISTER

R-0/0	R-1/1	U-0	R/W-0/0	R/W-0/0	U-0	R/W-0/0	R/W-0/0
ABDOVF	RCIDL	—	SCKP	BRG16	—	WUE	ABDEN
bit 7							bit 0

Legend:

R = Readable bit	W = Writable bit	U = Unimplemented bit, read as '0'
u = Bit is unchanged	x = Bit is unknown	-n/n = Value at POR and BOR/Value at all other Resets
'1' = Bit is set	'0' = Bit is cleared	

- bit 7 **ABDOVF:** Auto-Baud Detect Overflow bit
Asynchronous mode:
 1 = Auto-baud timer overflowed
 0 = Auto-baud timer did not overflow
Synchronous mode:
 Don't care
- bit 6 **RCIDL:** Receive Idle Flag bit
Asynchronous mode:
 1 = Receiver is Idle
 0 = Start bit has been received and the receiver is receiving
Synchronous mode:
 Don't care
- bit 5 **Unimplemented:** Read as '0'
- bit 4 **SCKP:** Must be '0'
- bit 3 **BRG16:** 16-bit Baud Rate Generator bit
 1 = 16-bit Baud Rate Generator is used
 0 = 8-bit Baud Rate Generator is used
- bit 2 **Unimplemented:** Read as '0'
- bit 1 **WUE:** Wake-up Enable bit
 1 = Receiver is waiting for a falling edge. No character will be received, byte RCIF will be set. WUE will automatically clear after RCIF is set.
 0 = Receiver is operating normally
- bit 0 **ABDEN:** Auto-Baud Detect Enable bit
 1 = Auto-Baud Detect mode is enabled (clears when auto-baud is complete)
 0 = Auto-Baud Detect mode is disabled

9.0 CONSIDERATION OF SPLIT POWER SUPPLIES AND DURING DEBUG

When the microcontroller is powered by a source other than the LIN Voltage Regulator, the following should be observed. This also applies when debugging and power the microcontroller from the emulator.

Leaving RB7/TX or RB6/LINCS outputs in a high state ('1') will source current into the internal voltage regulator and prevent the RESET circuit from detecting a Power-on-event. Always drive RB7/TX low when putting the transceiver into Power-Down mode by controlling RB6/CS = 0.

If the microcontroller is supplied by the debugging tool, be aware that the VBAT must be applied to the VBAT pin for the transceiver to operate.

PIC16F1829LIN

10.0 ELECTRICAL SPECIFICATIONS

Absolute Maximum Ratings^(†)

Ambient temperature under bias.....	-40°C to +125°C
Storage temperature.....	-65°C to +150°C
Voltage on VDD with respect to VSS.....	-0.3V to +6.5V
Voltage on $\overline{\text{MCLR}}$ with respect to VSS.....	-0.3V to +9.0V
Voltage on all other logic level pins with respect to VSS.....	-0.3V to (VDD + 0.3V)
Total power dissipation (Note 5).....	800 mW
Maximum current out of VSS pin, -40°C ≤ TA ≤ +125°C for extended.....	35 mA
Maximum current into VDD pin, -40°C ≤ TA ≤ +125°C for extended.....	30 mA
Clamp current, IK (VPIN < 0 or VPIN > VDD).....	± 20 mA
Maximum output current sunk by any I/O pin.....	25 mA
Maximum output current sourced by any I/O pin.....	25 mA
VBB Battery Voltage, non-operating (LIN bus recessive, no regulator load, t < 60s).....	-0.3 to +43V
VBB Battery Voltage, transient ISO 7637 Test 1	-200V
VBB Battery Voltage, transient ISO 7637 Test 2a	+150V
VBB Battery Voltage, transient ISO 7637 Test 3a	-300V
VBB Battery Voltage, transient ISO 7637 Test 3b	+200V
VBB Battery Voltage, continuous	-0.3 to +30V
VLBUS Bus Voltage, continuous.....	-18 to +30V
VLBUS Bus Voltage, transient (Note 1).....	-27 to +43V
ILBUS Bus Short Circuit Current Limit	200 mA
ESD protection on LIN, VBB (IEC 61000-4-2, 330 Ohm, 150 pF) (Note 3).....	Minimum ±9 kV
ESD protection on LIN, VBB (Charge Device Model) (Note 2).....	±1500V
ESD protection on LIN, VBB (Human Body Model, 1 kOhm, 100 pF) (Note 4).....	±8 kV
ESD protection on LIN, VBB (Machine Model) (Note 2).....	±800V
ESD protection on all other pins (Human Body Model) (Note 2).....	> 4 kV
Maximum Junction Temperature.....	150°C
Storage Temperature.....	-55 to +150°C

Note 1: ISO 7637/1 load dump compliant (t < 500 ms).

2: According to JESD22-A114-B.

3: According to IBEE, without bus filter.

4: Limited by Test Equipment.

5: Power dissipation is calculated as follows:

$$P_{DIS} = V_{DD} \times \{I_{DD} - \sum \{I_{OH}\} + \sum \{(V_{DD} - V_{OH}) \times I_{OH}\} + \sum \{V_{OL} \times I_{OL}\}.$$

† NOTICE: Stresses above those listed under “Absolute Maximum Ratings” may cause permanent damage to the device. This is a stress rating only and functional operation of the device at those or any other conditions above those indicated in the operation listings of this specification is not implied. Exposure above maximum rating conditions for extended periods may affect device reliability.

FIGURE 10-1: PIC16F1829LIN VOLTAGE FREQUENCY GRAPH, $-40^{\circ}\text{C} \leq T_A \leq +125^{\circ}\text{C}$

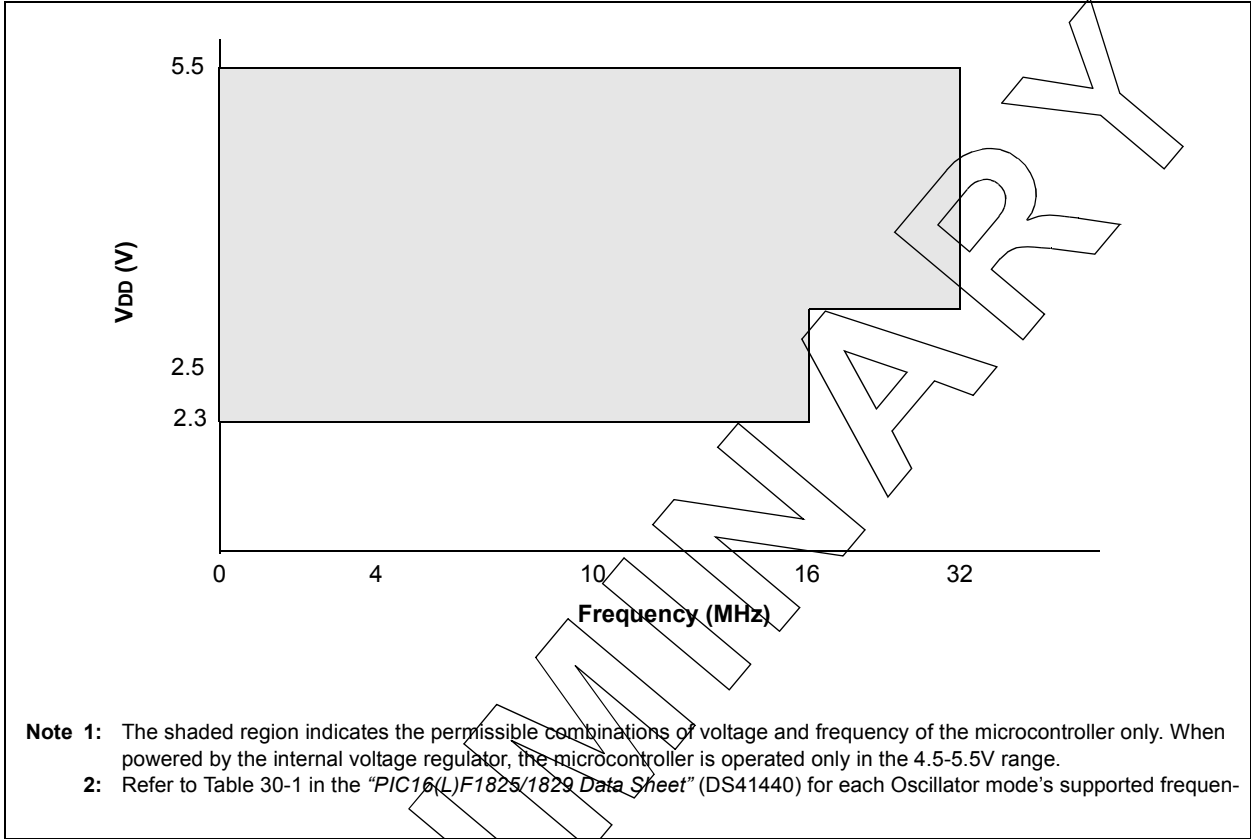
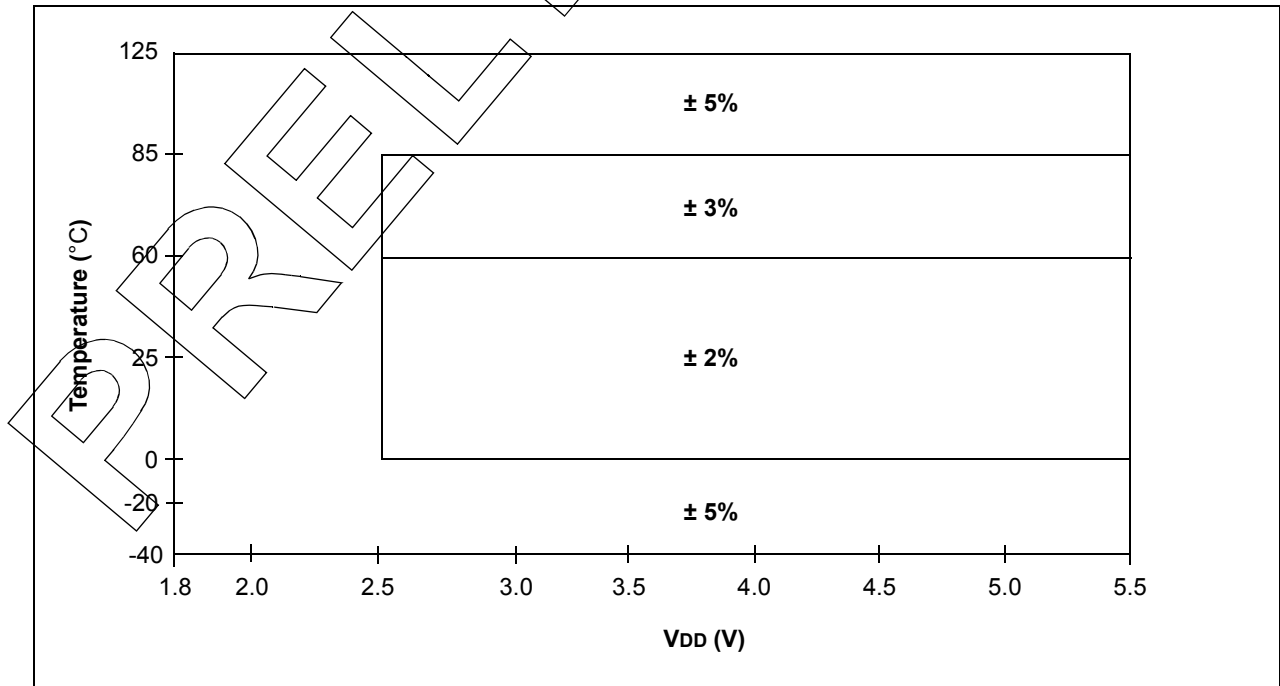

FIGURE 10-2: HFINTOSC FREQUENCY ACCURACY OVER DEVICE VDD AND TEMPERATURE



PIC16F1829LIN

10.1 DC Characteristics: PIC16F1829LIN-E (Extended)

PIC16F1829LIN		Standard Operating Conditions (unless otherwise stated)					
		Operating temperature $-40^{\circ}\text{C} \leq T_A \leq +125^{\circ}\text{C}$ for extended					
Param. No.	Sym.	Characteristic	Min.	Typ†	Max.	Units	Conditions
D001	VDD	Supply Voltage					
		PIC16F1829LIN	2.3	—	5.5	V	Fosc \leq 32 MHz (Note 1)

* These parameters are characterized but not tested.

† Data in "Typ" column is at 5.0V, 25°C unless otherwise stated. These parameters are for design guidance only and are not tested.

Note 1: PLL required for 32 MHz operation.

10.2 DC Characteristics: PIC16F1829LIN-E (Extended)

PIC16F1829LIN		Standard Operating Conditions (unless otherwise stated)						
		Operating temperature $-40^{\circ}\text{C} \leq T_A \leq +125^{\circ}\text{C}$ for extended						
Param. No.	Symbol	Device Characteristics	Min.	Typ†	Max.	Units	Conditions	
							VDD	
							Note	
TBD	IBBQ	Current for Transceiver and Voltage Regulator⁽¹⁾						
		VBB Quiescent Operating Current	—	115	210	μA	5.0	IOUT = 0 mA, LBUS recessive
		VBB Transmitter-off Current	—	90	190	μA	5.0	With VREG on, transmitter off, receiver on, FAULT/TXE = VIH, CS = VIH
TBD	IBBPD	VBB Power-down Current	—	16	26	μA	5.0	With VREG powered-off, receiver on and transmitter off, FAULT/TXE = VIH, TXD = VIH, CS = VIL
TBD	IBBNO-GND	VBB Current with VSS Floating	-1	—	1	mA	5.0	VBB = 12V, GND to VBB, VLIN = 0-18V
D010		Supply Current (IDD)^(2,3)						
			—	5.5	15	μA	1.8	Fosc = 32 kHz LP Oscillator
			—	7.8	18	μA	3.0	
D010			—	20	55	μA	1.8	Fosc = 32 kHz LP Oscillator
			—	25	60	μA	3.0	
			—	27	65	μA	5.0	

* These parameters are characterized but not tested.

† Data in "Typ" column is at 3.0V, 25°C unless otherwise stated. These parameters are for design guidance only and are not tested.

TBD = To be determined

- Note 1:** The peripheral current is the sum of the base IDD or IPD and the additional current consumed when this peripheral is enabled. The peripheral Δ current can be determined by subtracting the base IDD or IPD current from this limit. Maximum values should be used when calculating total current consumption.
- 2:** The test conditions for all IDD measurements in active Operation mode are: OSC1 = external square wave, from rail-to-rail; all I/O pins tri-stated, pulled to VDD; MCLR = VDD; WDT disabled.
- 3:** The supply current is mainly a function of the operating voltage and frequency. Other factors, such as I/O pin loading and switching rate, oscillator type, internal code execution pattern and temperature, also have an impact on the current consumption.
- 4:** 8 MHz internal RC oscillator with 4x PLL enabled.
- 5:** 8 MHz crystal oscillator with 4x PLL enabled.
- 6:** For RC oscillator configurations, current through REXT is not included. The current through the resistor can be extended by the formula $I_R = V_{DD}/2R_{EXT}$ (mA) with REXT in k Ω .

10.2 DC Characteristics: PIC16F1829LIN-E (Extended) (Continued)

PIC16F1829LIN			Standard Operating Conditions (unless otherwise stated) Operating temperature $-40^{\circ}\text{C} \leq T_A \leq +125^{\circ}\text{C}$ for extended					
Param. No.	Symbol	Device Characteristics	Min.	Typ†	Max.	Units	Conditions	
							VDD	Note
Supply Current (IDD)^(2, 3)								
D011			—	83	140	μA	1.8	FOSC = 1 MHz XT Oscillator
			—	130	230	μA	3.0	
D011			—	105	160	μA	1.8	FOSC = 1 MHz XT Oscillator
			—	160	250	μA	3.0	
			—	230	320	μA	5.0	
D012			—	220	310	μA	1.8	FOSC = 4 MHz XT Oscillator
			—	378	540	μA	3.0	
D012			—	240	300	μA	1.8	FOSC = 4 MHz XT Oscillator
			—	400	500	μA	3.0	
			—	500	760	μA	5.0	
D013			—	46	160	μA	1.8	FOSC = 1 MHz EC Oscillator Medium-Power mode
			—	90	230	μA	3.0	
D013			—	70	180	μA	1.8	FOSC = 1 MHz EC Oscillator Medium-Power mode
			—	120	240	μA	3.0	
			—	190	320	μA	5.0	

* These parameters are characterized but not tested.

† Data in "Typ" column is at 3.0V, 25°C unless otherwise stated. These parameters are for design guidance only and are not tested.

TBD = To be determined

- Note**
- The peripheral current is the sum of the base IDD or IPD and the additional current consumed when this peripheral is enabled. The peripheral current can be determined by subtracting the base IDD or IPD current from this limit. Maximum values should be used when calculating total current consumption.
 - The test conditions for all IDD measurements in active Operation mode are: OSC1 = external square wave, from rail-to-rail; all I/O pins tri-stated, pulled to VDD; MCLR = VDD; WDT disabled.
 - The supply current is mainly a function of the operating voltage and frequency. Other factors, such as I/O pin loading and switching rate, oscillator type, internal code execution pattern and temperature, also have an impact on the current consumption.
 - 8 MHz internal RC oscillator with 4x PLL enabled.
 - 8 MHz crystal oscillator with 4x PLL enabled.
 - For RC oscillator configurations, current through REXT is not included. The current through the resistor can be extended by the formula $I_R = V_{DD}/2R_{EXT}$ (mA) with REXT in k Ω .

PIC16F1829LIN

10.2 DC Characteristics: PIC16F1829LIN-E (Extended) (Continued)

PIC16F1829LIN				Standard Operating Conditions (unless otherwise stated) Operating temperature $-40^{\circ}\text{C} \leq T_A \leq +125^{\circ}\text{C}$ for extended				
Param. No.	Symbol	Device Characteristics	Min.	Typ†	Max.	Units	Conditions	
							V _{DD}	Note
D014		Supply Current (I _{DD}) ^(2, 3)	—	192	250	μA	1.8	Fosc = 4 MHz EC Oscillator Medium-Power mode
			—	336	430	μA	3.0	
D014			—	210	275	μA	1.8	Fosc = 4 MHz EC Oscillator Medium-Power mode
			—	356	450	μA	3.0	
			—	430	650	μA	5.0	
D015			—	6.5	18	μA	1.8	Fosc = 31 kHz LFINTOSC
			—	9.0	20	μA	3.0	
D015			—	20	60	μA	1.8	Fosc = 31 kHz LFINTOSC
			—	25	65	μA	3.0	
			—	27	70	μA	5.0	
D016			—	110	170	μA	1.8	Fosc = 500 kHz MFINTOSC
			—	130	200	μA	3.0	
D016			—	125	180	μA	1.8	Fosc = 500 kHz MFINTOSC
			—	155	250	μA	3.0	
			—	160	280	μA	5.0	
D017*			—	0.6	0.85	mA	1.8	Fosc = 8 MHz HFINTOSC
			—	0.9	1.25	mA	3.0	
D017*			—	0.6	0.85	mA	1.8	Fosc = 8 MHz HFINTOSC
			—	0.96	1.35	mA	3.0	
			—	1.03	1.55	mA	5.0	
D018			—	0.9	1.2	mA	1.8	Fosc = 16 MHz HFINTOSC
			—	1.4	1.95	mA	3.0	
D018			—	0.92	1.2	mA	1.8	Fosc = 16 MHz HFINTOSC
			—	1.49	1.9	mA	3.0	
			—	1.58	2.4	mA	5.0	

* These parameters are characterized but not tested.

† Data in "Typ" column is at 3.0V, 25°C unless otherwise stated. These parameters are for design guidance only and are not tested.

TBD = To be determined

- Note**
- The peripheral current is the sum of the base I_{DD} or I_{PD} and the additional current consumed when this peripheral is enabled. The peripheral Δ current can be determined by subtracting the base I_{DD} or I_{PD} current from this limit. Maximum values should be used when calculating total current consumption.
 - The test conditions for all I_{DD} measurements in active Operation mode are: OSC1 = external square wave, from rail-to-rail; all I/O pins tri-stated, pulled to V_{DD}; MCLR = V_{DD}; WDT disabled.
 - The supply current is mainly a function of the operating voltage and frequency. Other factors, such as I/O pin loading and switching rate, oscillator type, internal code execution pattern and temperature, also have an impact on the current consumption.
 - 8 MHz internal RC oscillator with 4x PLL enabled.
 - 8 MHz crystal oscillator with 4x PLL enabled.
 - For RC oscillator configurations, current through R_{EXT} is not included. The current through the resistor can be extended by the formula $I_R = V_{DD}/2R_{EXT}$ (mA) with R_{EXT} in kΩ.

10.2 DC Characteristics: PIC16F1829LIN-E (Extended) (Continued)

PIC16F1829LIN			Standard Operating Conditions (unless otherwise stated) Operating temperature $-40^{\circ}\text{C} \leq T_A \leq +125^{\circ}\text{C}$ for extended					
Param. No.	Symbol	Device Characteristics	Min.	Typ†	Max.	Units	Conditions	
							V _{DD}	Note
D019		Supply Current (I _{DD}) ^(2, 3)	—	2.8	3.6	mA	3.0	Fosc = 32 MHz HFINTOSC (Note 4)
			—	3.4	3.9	mA	3.6	
D019			—	2.8	4.0	mA	3.0	Fosc = 32 MHz HFINTOSC (Note 4)
			—	3.0	4.5	mA	5.0	
D020			—	2.7	3.6	mA	3.0	Fosc = 32 MHz HS Oscillator (Note 5)
			—	3.2	4.2	mA	3.6	
D020			—	2.7	4.0	mA	3.0	Fosc = 32 MHz HS Oscillator (Note 5)
			—	3.2	4.3	mA	5.0	
D021			—	222	350	μA	1.8	Fosc = 4 MHz EXTRC (Note 6)
			—	400	690	μA	3.0	
D021			—	240	500	μA	1.8	Fosc = 4 MHz EXTRC (Note 6)
			—	416	800	μA	3.0	
			—	497	900	μA	5.0	

* These parameters are characterized but not tested.

† Data in "Typ" column is at 3.0V, 25°C unless otherwise stated. These parameters are for design guidance only and are not tested.

TBD = To be determined

- Note 1:** The peripheral current is the sum of the base I_{DD} or I_{PD} and the additional current consumed when this peripheral is enabled. The peripheral Δ current can be determined by subtracting the base I_{DD} or I_{PD} current from this limit. Maximum values should be used when calculating total current consumption.
- Note 2:** The test conditions for all I_{DD} measurements in active Operation mode are: OSC1 = external square wave, from rail-to-rail; all I/O pins tri-stated, pulled to V_{DD}; MCLR = V_{DD}; WDT disabled.
- Note 3:** The supply current is mainly a function of the operating voltage and frequency. Other factors, such as I/O pin loading and switching rate, oscillator type, internal code execution pattern and temperature, also have an impact on the current consumption.
- Note 4:** 8 MHz internal RC oscillator with 4x PLL enabled.
- Note 5:** 8 MHz crystal oscillator with 4x PLL enabled.
- Note 6:** For RC oscillator configurations, current through R_{EXT} is not included. The current through the resistor can be extended by the formula $I_R = V_{DD}/2R_{EXT}$ (mA) with R_{EXT} in kΩ.

PIC16F1829LIN

11.0 PACKAGING INFORMATION

11.1 Package Marking Information

20-Lead SSOP (5.30 mm)

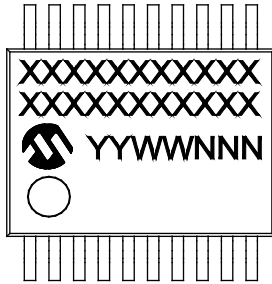

Example

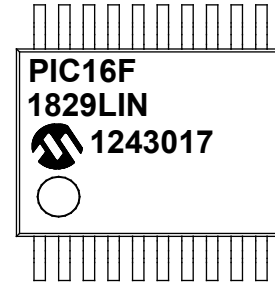

Legend:	XX...X	Customer-specific information
	Y	Year code (last digit of calendar year)
	YY	Year code (last 2 digits of calendar year)
	WW	Week code (week of January 1 is week '01')
	NNN	Alphanumeric traceability code
	(e3)	Pb-free JEDEC designator for Matte Tin (Sn)
	*	This package is Pb-free. The Pb-free JEDEC designator (e3) can be found on the outer packaging for this package.
Note:	In the event the full Microchip part number cannot be marked on one line, it will be carried over to the next line, thus limiting the number of available characters for customer-specific information.	

- * Standard PIC[®] device marking consists of Microchip part number, year code, week code, and traceability code. For PIC device marking beyond this, certain price adders apply. Please check with your Microchip Sales Office. For QTP devices, any special marking adders are included in QTP price.

11.2 Package Details

The following sections give the technical details of the packages.

20-Lead Plastic Shrink Small Outline (SS) – 5.30 mm Body [SSOP]

Note: For the most current package drawings, please see the Microchip Packaging Specification located at <http://www.microchip.com/packaging>

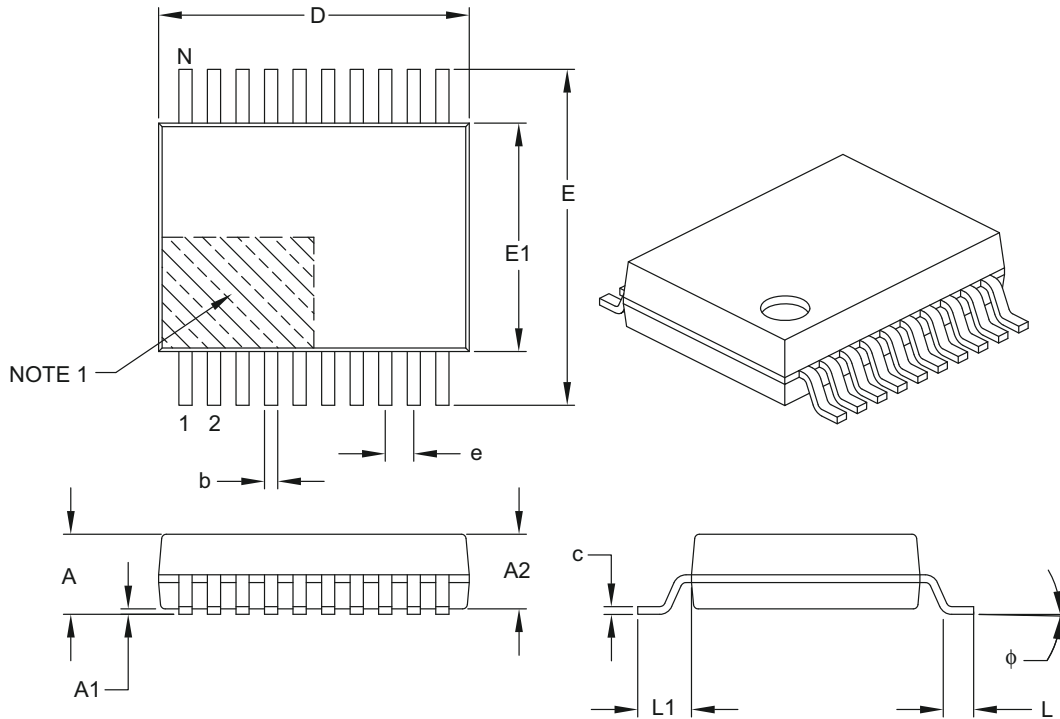

		Units	MILLIMETERS		
Dimension Limits			MIN	NOM	MAX
Number of Pins	N		20		
Pitch	e		0.65 BSC		
Overall Height	A	–	–	–	2.00
Molded Package Thickness	A2		1.65	1.75	1.85
Standoff	A1		0.05	–	–
Overall Width	E		7.40	7.80	8.20
Molded Package Width	E1		5.00	5.30	5.60
Overall Length	D		6.90	7.20	7.50
Foot Length	L		0.55	0.75	0.95
Footprint	L1		1.25 REF		
Lead Thickness	c		0.09	–	0.25
Foot Angle	ϕ		0°	4°	8°
Lead Width	b		0.22	–	0.38

Notes:

- Pin 1 visual index feature may vary, but must be located within the hatched area.
- Dimensions D and E1 do not include mold flash or protrusions. Mold flash or protrusions shall not exceed 0.20 mm per side.
- Dimensioning and tolerancing per ASME Y14.5M.

BSC: Basic Dimension. Theoretically exact value shown without tolerances.

REF: Reference Dimension, usually without tolerance, for information purposes only.

Microchip Technology Drawing C04-072B

PIC16F1829LIN

20-Lead Plastic Shrink Small Outline (SS) - 5.30 mm Body [SSOP]

Note: For the most current package drawings, please see the Microchip Packaging Specification located at <http://www.microchip.com/packaging>

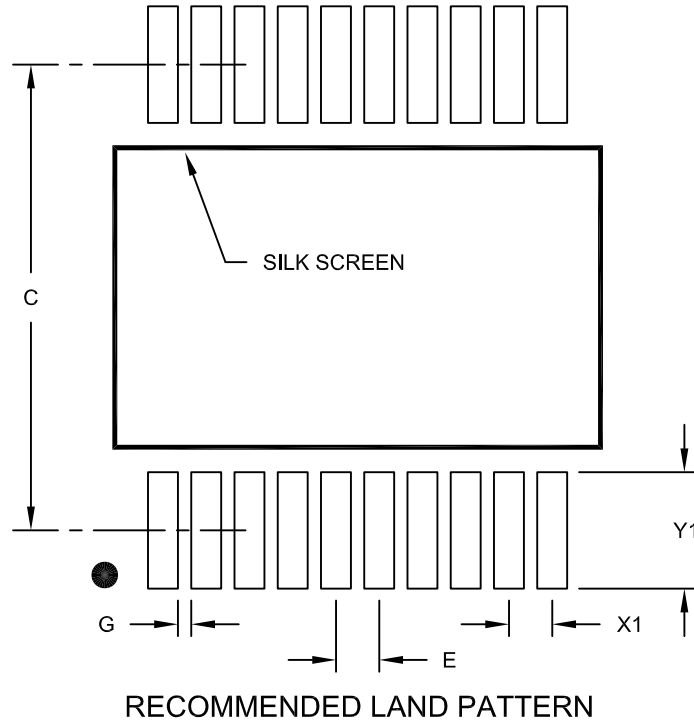

		Units	MILLIMETERS		
		Dimension Limits	MIN	NOM	MAX
Contact Pitch	E	0.65 BSC			
Contact Pad Spacing	C		7.20		
Contact Pad Width (X20)	X1				0.45
Contact Pad Length (X20)	Y1				1.75
Distance Between Pads	G	0.20			

Notes:

1. Dimensioning and tolerancing per ASME Y14.5M

BSC: Basic Dimension. Theoretically exact value shown without tolerances.

Microchip Technology Drawing No. C04-2072A

APPENDIX A: DATA SHEET REVISION HISTORY

Revision A (12/2012)

Initial release.

PIC16F1829LIN

INDEX

A

Absolute Maximum Ratings	55
ADC	45
Associated Registers	47
Block Diagram	45
ADCON0 Register	25, 46
ADCON1 Register	25
ADRESH Register	25
Alternate Pin Function	35
Analog Features	1
Analog-to-Digital Converter. <i>See</i> ADC	
ANSELB Register	39
ANSELC Register	43
APFCON0 Register	35
APFCON1 Register	36
Asynchronous Reception Setup	50
Asynchronous Transmission Setup	49

B

BAUDCON Register	53
Block Diagrams	
ADC	45
PIC16F1829LIN	7, 17

C

CCP1CON Register	29, 30
CCPR1H Register	29, 30
CCPR1L Register	29, 30
Code Examples	
Initializing PORTB	37
Initializing PORTC	41
Cross-Referenced Material	1
Customer Change Notification Service	67
Customer Notification Service	67
Customer Support	67

D

DC Characteristics	
Extended	57
Device Overview	6

E

Electrical Specifications	55
Enhanced Mid-range CPU	17
Enhanced Universal Synchronous Asynchronous Receiver Transmitter (EUSART)	49
Errata	5
EUSART	49
Asynchronous Mode	
Associated Registers	
Receive	50
Transmit	49

F

Flexible Oscillator Structure	1
FSR Register	24, 25, 26, 27, 28, 29, 30, 31, 32, 33, 34

H

Hardware	11
High-Performance RISC CPU	1

I

I/O Ports	35
INDF Register	24, 25, 26, 27, 28, 29, 30, 31, 32, 33, 34

INLVLB Register	40
INLVLC Register	44
Internet Address	67

L

LATA Register	43
LATB Register	39

M

Master SSPx (MSSPx) Module Overview	48
Master Synchronous Serial Port. <i>See</i> MSSPx	
Memory Organization	18
Microchip Internet Web Site	67
MSSPx	48

P

Packaging	
SSOP	62
Packaging Information	61
PCL Register	24, 25, 26, 27, 28, 29, 30, 31, 32, 33, 34
PCLATH Register	24, 25, 26, 27, 28, 29, 30, 31, 32, 33, 34
PCON Register	25
Peripheral Features	1
PIE1 Register	25
PIE2 Register	25
PIE3 Register	25
PIE4 Register	25
Pinout Descriptions	
PIC16F1829LIN	8
PIR1 Register	24
PIR2 Register	24
PIR3 Register	24
PIR4 Register	24
PORTA	
LATA Register	26
PORTA Register	24
PORTB	
ANSELB Register	37
Associated Registers	40
LATB Register	26
PORTB Register	24
PORTB Register	38
PORTB Registers	37
PORTC	
ANSELC Register	41
Associated Registers	44
LATC Register	26
PORTC Functions and Output Priorities	41
PORTC Register	24
PORTC Register	42
PORTC Registers	41
PR2 Register	24
PR4 Register	32
PR6 Register	32

R

RCREG Register	27
RCSTA Register	27, 52
Reader Response	68
Registers	
ADCON0 (ADC Control 0)	46
ANSELB (PORTB Analog Select)	39
ANSELC (PORTC Analog Select)	43
APFCON0 (Alternate Pin Function Control 0)	35

APFCON1 (Alternate Pin Function Control 1).....	36
BAUDCON (Baud Rate Control).....	53
INLVLB (Input Level Control PORTB).....	40
INLVLC (Input Level Control PORTC).....	44
LATB (Data Latch PORTB).....	39
LATC (Data Latch PORTC).....	43
PORTB.....	38
PORTC.....	42
RCSTA (Receive Status and Control).....	52
Special Function, Summary.....	24
TRISB (Tri-State PORTB).....	38
TRISC (Tri-State PORTC).....	42
TXSTA (Transmit Status and Control).....	51
WPUB (Weak Pull-up PORTB).....	40
WPUC (Weak Pull-up PORTC).....	44
Revision History.....	64
Routing CCP4 to a Pin.....	15

S

Software.....	12
SPBRG Register.....	27
Special Function Registers (SFRs).....	24
Special Microcontroller Features.....	1
SPI Mode (MSSPx)	
Associated Registers.....	48
SSP1ADD Register.....	28
SSP1BUF Register.....	28
SSP1CON Register.....	28
SSP1CON2 Register.....	28
SSP1CON3 Register.....	28
SSP1MSK Register.....	28
SSP1STAT Register.....	28
SSP2ADD Register.....	28
SSP2BUF Register.....	28
SSP2CON Register.....	28
SSP2CON2 Register.....	28
SSP2CON3 Register.....	28
SSP2MSK Register.....	28
SSP2STAT Register.....	28

T

T1CON Register.....	24
T2CON Register.....	24
T4CON Register.....	32
T6CON Register.....	32
TMR0 Register.....	24
TMR1H Register.....	24
TMR1L Register.....	24
TMR2 Register.....	24
TMR4 Register.....	32
TMR6 Register.....	32
TRISA Register.....	25
TRISB Register.....	25, 38
TRISC Register.....	25, 42
TXREG Register.....	27
TXSTA Register.....	27, 51

U

Using the PIC16F1829LIN in LIN Bus Applications.....	11
--	----

W

WPUB Register.....	40
WPUC Register.....	44
WWW Address.....	67
WWW, On-Line Support.....	5

PIC16F1829LIN

THE MICROCHIP WEB SITE

Microchip provides online support via our WWW site at www.microchip.com. This web site is used as a means to make files and information easily available to customers. Accessible by using your favorite Internet browser, the web site contains the following information:

- **Product Support** – Data sheets and errata, application notes and sample programs, design resources, user's guides and hardware support documents, latest software releases and archived software
- **General Technical Support** – Frequently Asked Questions (FAQ), technical support requests, online discussion groups, Microchip consultant program member listing
- **Business of Microchip** – Product selector and ordering guides, latest Microchip press releases, listing of seminars and events, listings of Microchip sales offices, distributors and factory representatives

CUSTOMER CHANGE NOTIFICATION SERVICE

Microchip's customer notification service helps keep customers current on Microchip products. Subscribers will receive e-mail notification whenever there are changes, updates, revisions or errata related to a specified product family or development tool of interest.

To register, access the Microchip web site at www.microchip.com. Under "Support", click on "Customer Change Notification" and follow the registration instructions.

CUSTOMER SUPPORT

Users of Microchip products can receive assistance through several channels:

- Distributor or Representative
- Local Sales Office
- Field Application Engineer (FAE)
- Technical Support
- Development Systems Information Line

Customers should contact their distributor, representative or field application engineer (FAE) for support. Local sales offices are also available to help customers. A listing of sales offices and locations is included in the back of this document.

Technical support is available through the web site at: <http://microchip.com/support>

READER RESPONSE

It is our intention to provide you with the best documentation possible to ensure successful use of your Microchip product. If you wish to provide your comments on organization, clarity, subject matter, and ways in which our documentation can better serve you, please FAX your comments to the Technical Publications Manager at (480) 792-4150.

Please list the following information, and use this outline to provide us with your comments about this document.

TO: Technical Publications Manager Total Pages Sent _____

RE: Reader Response

From: Name _____

Company _____

Address _____

City / State / ZIP / Country _____

Telephone: (_____) _____ - _____ FAX: (_____) _____ - _____

Application (optional):

Would you like a reply? Y N

Device: PIC16F1829LIN

Literature Number: DS41673A

Questions:

1. What are the best features of this document?

2. How does this document meet your hardware and software development needs?

3. Do you find the organization of this document easy to follow? If not, why?

4. What additions to the document do you think would enhance the structure and subject?

5. What deletions from the document could be made without affecting the overall usefulness?

6. Is there any incorrect or misleading information (what and where)?

7. How would you improve this document?

PIC16F1829LIN

PRODUCT IDENTIFICATION SYSTEM

To order or obtain information, e.g., on pricing or delivery, refer to the factory or the listed sales office.

<u>PART NO.</u>	<u>[X]⁽¹⁾</u>	-	<u>X</u>	<u>/XX</u>	<u>XXX</u>
Device	Tape and Reel Option		Temperature Range	Package	Pattern
Device:	PIC16F1829LIN				
Tape and Reel Option:	Blank = Standard packaging (tube or tray) T = Tape and Reel ⁽¹⁾				
Temperature Range:	E = -40°C to +125°C (Extended)				
Package:⁽²⁾	SS = SSOP				
Pattern:	QTP, SQTP, Code or Special Requirements (blank otherwise)				

Examples:

a) PIC16F1829LIN - E/SS
Extended temperature,
SSOP package

Note 1: Tape and Reel identifier only appears in the catalog part number description. This identifier is used for ordering purposes and is not printed on the device package. Check with your Microchip Sales Office for package availability with the Tape and Reel option.

2: For other small form-factor package availability and marking information, please visit www.microchip.com/packaging or contact your local sales office.

Note the following details of the code protection feature on Microchip devices:

- Microchip products meet the specification contained in their particular Microchip Data Sheet.
- Microchip believes that its family of products is one of the most secure families of its kind on the market today, when used in the intended manner and under normal conditions.
- There are dishonest and possibly illegal methods used to breach the code protection feature. All of these methods, to our knowledge, require using the Microchip products in a manner outside the operating specifications contained in Microchip's Data Sheets. Most likely, the person doing so is engaged in theft of intellectual property.
- Microchip is willing to work with the customer who is concerned about the integrity of their code.
- Neither Microchip nor any other semiconductor manufacturer can guarantee the security of their code. Code protection does not mean that we are guaranteeing the product as “unbreakable.”

Code protection is constantly evolving. We at Microchip are committed to continuously improving the code protection features of our products. Attempts to break Microchip's code protection feature may be a violation of the Digital Millennium Copyright Act. If such acts allow unauthorized access to your software or other copyrighted work, you may have a right to sue for relief under that Act.

Information contained in this publication regarding device applications and the like is provided only for your convenience and may be superseded by updates. It is your responsibility to ensure that your application meets with your specifications. MICROCHIP MAKES NO REPRESENTATIONS OR WARRANTIES OF ANY KIND WHETHER EXPRESS OR IMPLIED, WRITTEN OR ORAL, STATUTORY OR OTHERWISE, RELATED TO THE INFORMATION, INCLUDING BUT NOT LIMITED TO ITS CONDITION, QUALITY, PERFORMANCE, MERCHANTABILITY OR FITNESS FOR PURPOSE. Microchip disclaims all liability arising from this information and its use. Use of Microchip devices in life support and/or safety applications is entirely at the buyer's risk, and the buyer agrees to defend, indemnify and hold harmless Microchip from any and all damages, claims, suits, or expenses resulting from such use. No licenses are conveyed, implicitly or otherwise, under any Microchip intellectual property rights.

Trademarks

The Microchip name and logo, the Microchip logo, dsPIC, FlashFlex, KEELOQ, KEELOQ logo, MPLAB, PIC, PICmicro, PICSTART, PIC³² logo, rPIC, SST, SST Logo, SuperFlash and UNI/O are registered trademarks of Microchip Technology Incorporated in the U.S.A. and other countries.

FilterLab, Hampshire, HI-TECH C, Linear Active Thermistor, MTP, SEEVAL and The Embedded Control Solutions Company are registered trademarks of Microchip Technology Incorporated in the U.S.A.

Silicon Storage Technology is a registered trademark of Microchip Technology Inc. in other countries.

Analog-for-the-Digital Age, Application Maestro, BodyCom, chipKIT, chipKIT logo, CodeGuard, dsPICDEM, dsPICDEM.net, dsPICworks, dsSPEAK, ECAN, ECONOMONITOR, FanSense, HI-TIDE, In-Circuit Serial Programming, ICSP, Mindi, MiWi, MPASM, MPF, MPLAB Certified logo, MPLIB, MPLINK, mTouch, Omniclient Code Generation, PICC, PICC-18, PICDEM, PICDEM.net, PICkit, PICtail, REAL ICE, rLAB, Select Mode, SQI, Serial Quad I/O, Total Endurance, TSHARC, UniWinDriver, WiperLock, ZENA and Z-Scale are trademarks of Microchip Technology Incorporated in the U.S.A. and other countries.

SQTP is a service mark of Microchip Technology Incorporated in the U.S.A.

GestIC and ULPP are registered trademarks of Microchip Technology Germany II GmbH & Co. & KG, a subsidiary of Microchip Technology Inc., in other countries.

All other trademarks mentioned herein are property of their respective companies.

© 2012, Microchip Technology Incorporated, Printed in the U.S.A., All Rights Reserved.

 Printed on recycled paper.

ISBN: 9781620768204

QUALITY MANAGEMENT SYSTEM
CERTIFIED BY DNV
== ISO/TS 16949 ==

Microchip received ISO/TS-16949:2009 certification for its worldwide headquarters, design and wafer fabrication facilities in Chandler and Tempe, Arizona; Gresham, Oregon and design centers in California and India. The Company's quality system processes and procedures are for its PIC® MCUs and dsPIC® DSCs, KEELOQ® code hopping devices, Serial EEPROMs, microperipherals, nonvolatile memory and analog products. In addition, Microchip's quality system for the design and manufacture of development systems is ISO 9001:2000 certified.



MICROCHIP

Worldwide Sales and Service

AMERICAS

Corporate Office
2355 West Chandler Blvd.
Chandler, AZ 85224-6199
Tel: 480-792-7200
Fax: 480-792-7277
Technical Support:
<http://www.microchip.com/support>
Web Address:
www.microchip.com

Atlanta
Duluth, GA
Tel: 678-957-9614
Fax: 678-957-1455

Boston
Westborough, MA
Tel: 774-760-0087
Fax: 774-760-0088

Chicago
Itasca, IL
Tel: 630-285-0071
Fax: 630-285-0075

Cleveland
Independence, OH
Tel: 216-447-0464
Fax: 216-447-0643

Dallas
Addison, TX
Tel: 972-818-7423
Fax: 972-818-2924

Detroit
Farmington Hills, MI
Tel: 248-538-2250
Fax: 248-538-2260

Indianapolis
Noblesville, IN
Tel: 317-773-8323
Fax: 317-773-5453

Los Angeles
Mission Viejo, CA
Tel: 949-462-9523
Fax: 949-462-9608

Santa Clara
Santa Clara, CA
Tel: 408-961-6444
Fax: 408-961-6445

Toronto
Mississauga, Ontario,
Canada
Tel: 905-673-0699
Fax: 905-673-6509

ASIA/PACIFIC

Asia Pacific Office
Suites 3707-14, 37th Floor
Tower 6, The Gateway
Harbour City, Kowloon
Hong Kong
Tel: 852-2401-1200
Fax: 852-2401-3431

Australia - Sydney
Tel: 61-2-9868-6733
Fax: 61-2-9868-6755

China - Beijing
Tel: 86-10-8569-7000
Fax: 86-10-8528-2104

China - Chengdu
Tel: 86-28-8665-5511
Fax: 86-28-8665-7889

China - Chongqing
Tel: 86-23-8980-9588
Fax: 86-23-8980-9500

China - Hangzhou
Tel: 86-571-2819-3187
Fax: 86-571-2819-3189

China - Hong Kong SAR
Tel: 852-2943-5100
Fax: 852-2401-3431

China - Nanjing
Tel: 86-25-8473-2460
Fax: 86-25-8473-2470

China - Qingdao
Tel: 86-532-8502-7355
Fax: 86-532-8502-7205

China - Shanghai
Tel: 86-21-5407-5533
Fax: 86-21-5407-5066

China - Shenyang
Tel: 86-24-2334-2829
Fax: 86-24-2334-2393

China - Shenzhen
Tel: 86-755-8864-2200
Fax: 86-755-8203-1760

China - Wuhan
Tel: 86-27-5980-5300
Fax: 86-27-5980-5118

China - Xian
Tel: 86-29-8833-7252
Fax: 86-29-8833-7256

China - Xiamen
Tel: 86-592-2388138
Fax: 86-592-2388130

China - Zhuhai
Tel: 86-756-3210040
Fax: 86-756-3210049

ASIA/PACIFIC

India - Bangalore
Tel: 91-80-3090-4444
Fax: 91-80-3090-4123

India - New Delhi
Tel: 91-11-4160-8631
Fax: 91-11-4160-8632

India - Pune
Tel: 91-20-2566-1512
Fax: 91-20-2566-1513

Japan - Osaka
Tel: 81-6-6152-7160
Fax: 81-6-6152-9310

Japan - Tokyo
Tel: 81-3-6880-3770
Fax: 81-3-6880-3771

Korea - Daegu
Tel: 82-53-744-4301
Fax: 82-53-744-4302

Korea - Seoul
Tel: 82-2-554-7200
Fax: 82-2-558-5932 or
82-2-558-5934

Malaysia - Kuala Lumpur
Tel: 60-3-6201-9857
Fax: 60-3-6201-9859

Malaysia - Penang
Tel: 60-4-227-8870
Fax: 60-4-227-4068

Philippines - Manila
Tel: 63-2-634-9065
Fax: 63-2-634-9069

Singapore
Tel: 65-6334-8870
Fax: 65-6334-8850

Taiwan - Hsin Chu
Tel: 886-3-5778-366
Fax: 886-3-5770-955

Taiwan - Kaohsiung
Tel: 886-7-213-7828
Fax: 886-7-330-9305

Taiwan - Taipei
Tel: 886-2-2508-8600
Fax: 886-2-2508-0102

Thailand - Bangkok
Tel: 66-2-694-1351
Fax: 66-2-694-1350

EUROPE

Austria - Wels
Tel: 43-7242-2244-39
Fax: 43-7242-2244-393

Denmark - Copenhagen
Tel: 45-4450-2828
Fax: 45-4485-2829

France - Paris
Tel: 33-1-69-53-63-20
Fax: 33-1-69-30-90-79

Germany - Munich
Tel: 49-89-627-144-0
Fax: 49-89-627-144-44

Italy - Milan
Tel: 39-0331-742611
Fax: 39-0331-466781

Netherlands - Drunen
Tel: 31-416-690399
Fax: 31-416-690340



Spain - Madrid
Tel: 34-91-708-08-90
Fax: 34-91-708-08-91

UK - Wokingham
Tel: 44-118-921-5869
Fax: 44-118-921-5820

11/29/12

Looking for pricing, stock, or lifecycle information?

Click below to explore more details on WIN SOURCE:

-  [View PIC16F1829LINT-E/SSVAO on WIN SOURCE](#)
-  [Microchip Technology](#) Information

Optimize Your Supply Chain with WIN SOURCE Solutions

-  Global Sourcing Solution
-  Obsolete Management
-  Cost Control Management
-  Shortage Management
-  Alternative Solution
-  Excess Inventory Management