



**THE DATASHEET OF
PMA3-313GLN+**





Monolithic Amplifier PMA3-313GLN+

50Ω 26.5 to 31 GHz

THE BIG DEAL

- High Gain 18.2 dB at 30 GHz
- Excellent Gain Flatness, ±1dB from 26.5 to 31 GHz
- Low NF, 1.8 dB at 30 GHz
- P1dB, 12.2 typ. at 30 GHz
- OIP3, 21.5dBm typ. at 30 GHz
- Built-In Bias Tee and DC Blocks
- Patent pending

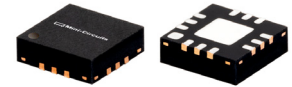

Generic photo used for illustration purposes only

CASE STYLE: DQ1225

+RoHS Compliant

The +Suffix identifies RoHS Compliance. See our web site for RoHS Compliance methodologies and qualifications

APPLICATIONS

- 5G
- Fixed Satellite
- Mobile

PRODUCT OVERVIEW

The PMA3-313GLN+ is a PHEMT based high gain, low noise MMIC amplifier with a unique combination of high gain, excellent gain flatness and low noise figure, making it ideal for using as the first stage driver amplifier of receiver applications. This design operates on a single 4V supply, is matched to 50Ohm and comes in a tiny plastic package (3 x 3 x 0.89mm), accommodating dense circuit board layouts.

KEY FEATURES

Feature	Advantages
Low noise, 1.8 dB at 30 GHz	Enables lower system noise figure performance.
High Gain, 20.1 dB at 30 GHz	Enables signal amplification without the need for multiple gain stage, minimizing the effect of subsequent stages on noise figure.
Excellent Gain Flatness	Typical ±1dB gain flatness across the entire frequency range minimizes the need for external equalizer networks, making it a great fit for instrumentation and EW applications.
Built-in Bias Tee & DC Blocks	Minimizes the external component count & PC board space, making it less expensive and user friendly for system designers.
3 x 3mm 12-lead MCLP package	Tiny footprint saves space in dense layouts while providing low inductance, repeatable transitions, and excellent thermal contact to the PCB.

*Electrical maximum ratings are not intended for continuous normal operation.

REV. C
ECO-011519
PMA3-313GLN+
GY/RS/CP/AM
220120



HIGH GAIN, LOW NOISE

Monolithic Amplifier PMA3-313GLN+

Mini-Circuits

ELECTRICAL SPECIFICATIONS¹ AT 25°C, VS=4V AND R1=18Ω, UNLESS NOTED OTHERWISE

Parameter	Condition (GHz)	Vs=4.0V			Units
		Min.	Typ.	Max.	
Frequency Range		26.5		31	GHz
Noise Figure	26.5		1.6		dB
	27.5		1.7		
	30		1.8		
	31		1.8		
Gain	26.5	17.0	21.4	25.1	dB
	27.5	16.1	20.7	23.9	
	30	14.5	20.1	23.9	
	31		19.4	—	
Input Return Loss	26.5		10		dB
	27.5		9		
	30		12		
	31		13		
Output Return Loss	26.5		7		dB
	27.5		8		
	30		12		
	31		10		
Output Power @ 1 dB compression	26.5		12.0		dBm
	27.5		12.0		
	30		12.2		
	31		12.3		
Output IP3	26.5		21.5		dBm
	27.5		21.6		
	30		21.5		
	31		21.6		
Supply Voltage (Vs)		3.75	4.0	4.25	V
Device Operating Current (IDD)			78	112	mA
Device Current Variation vs. Temperature ²			-50		μA/°C
Device Current Variation vs. Voltage			0.02		mA/mV
Thermal Resistance, junction-to-ground lead			106		°C/W

1. Measured on Mini-Circuits Characterization test board TB-PMA3-313GLN+ with thru-line loss being deducted. See Characterization Test Circuit (Fig. 1)

2. Device Current Variation vs. Temperature = (Current at 85°C - Current at -45°C)/130°C

MAXIMUM RATINGS³

Parameter	Ratings
Operating Temperature (ground lead)	-40°C to 85°C
Storage Temperature	-65°C to 150°C
Junction Temperature	146°C
Total Power Dissipation	0.65W
Input Power (CW), Vs=4V	+23 dBm (5 minutes max.) +13 dBm (continuous)
DC Voltage at Port 2 & 8	2V
DC Voltage (Vs)	6V

3. Permanent damage may occur if any of these limits are exceeded.





HIGH GAIN, LOW NOISE

Monolithic Amplifier PMA3-313GLN+

SIMPLIFIED SCHEMATIC AND PAD DESCRIPTION

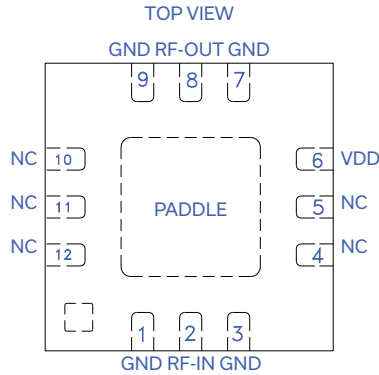
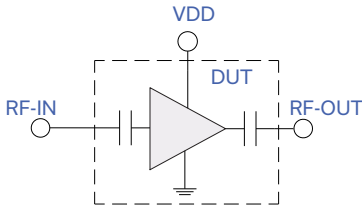

Function	Pad Number	Description (See Application Circuit, Fig. 1)
RF-IN	2	RF Input Pad. Connects to RF input
RF-OUT	8	RF Output Pad. Connects to RF output
VDD	6	DC Power Supply Pad. Connects to Voltage Source Vs via R1
Ground	1,3,7,9 & Paddle	Connects to ground
No Connection	4,5,10,11 & 12	Not used internally. Connected to ground on test board

RECOMMENDED APPLICATION AND CHARACTERIZATION TEST CIRCUIT

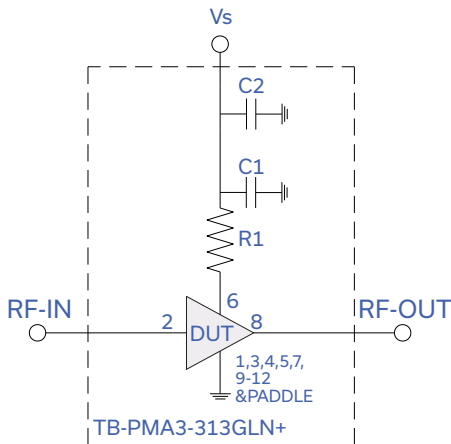

Fig 1. Application and Characterization Circuit

Note: This block diagram is used for characterization. (DUT is soldered on Mini-Circuits Characterization test board TB-PMA3-313GLN+) Gain, Return loss, Output power at 1dB compression (P1 dB), output IP3 (OIP3) and noise figure measured using Agilent's N5245A microwave network analyzer.

Conditions:

1. Gain and Return loss: Pin= -25dBm
2. Output IP3 (OIP3): Two tones, spaced 1 MHz apart, -5dBm/tone at output.

Component	Size	Value	Part Number	Manufacturer
R1	0603	18 Ohm	SG73G1JTTD18R0C	KOA
C1	0402	5 pF	GJM1555C1H5R0CB01D	Murata
C2	0402	0.1 uF	GRM155R71C104KA88D	Murata

PRODUCT MARKING

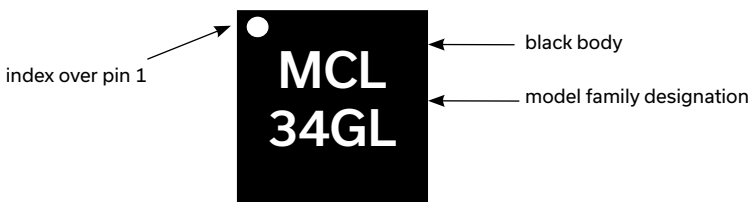

Marking may contain other features or characters for internal lot control





HIGH GAIN, LOW NOISE

Monolithic Amplifier PMA3-313GLN+

Mini-Circuits

ADDITIONAL DETAILED TECHNICAL INFORMATION IS AVAILABLE ON OUR DASH BOARD. TO ACCESS [CLICK HERE](#)

Performance Data	Data Table graphs, s-parameter data set (.zip file)
Case Style	DQ1225 Plastic package, exposed paddle, lead finish: Matte Tin
Tape & Reel Standard quantities available on reel	F66 7" reels with 20, 50, 100, 200, 500, 1K, or 2K devices.
Suggested Layout for PCB Design	PL-674
Evaluation Board	TB-PMA3-313GLN+ (Without connectors) TB-PMA3313GLNC+ (With connectors)
Environmental Ratings	ENV08T1

ESD RATING

Human Body Model (HBM): Class 1A (250 to <500V) in accordance with ANSI/ESD STM 5.1 - 2001

MSL RATING

Moisture Sensitivity: MSL1 in accordance with IPC/JEDEC J-STD-020D

MSL TEST FLOW CHART

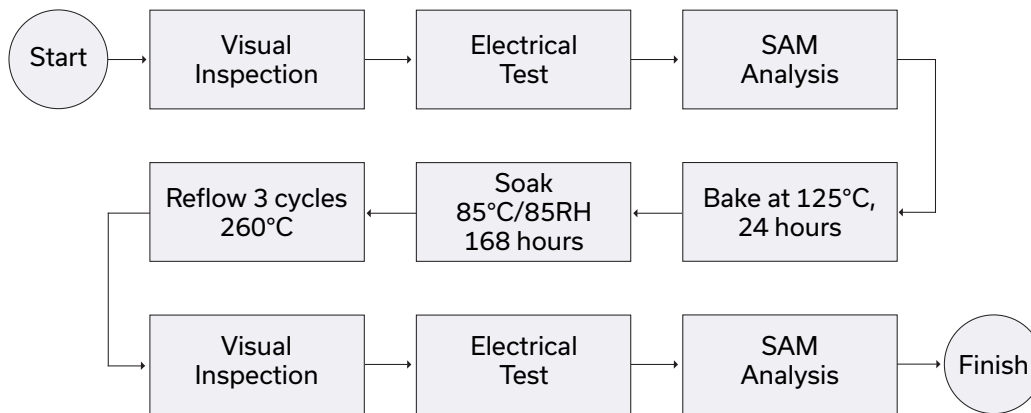

- NOTES**
- A. Performance and quality attributes and conditions not expressly stated in this specification document are intended to be excluded and do not form a part of this specification document.
 - B. Electrical specifications and performance data contained in this specification document are based on Mini-Circuit's applicable established test performance criteria and measurement instructions.
 - C. The parts covered by this specification document are subject to Mini-Circuits standard limited warranty and terms and conditions (collectively, "Standard Terms"); Purchasers of this part are entitled to the rights and benefits contained therein. For a full statement of the standard. Terms and the exclusive rights and remedies thereunder, please visit Mini-Circuits' website at www.minicircuits.com/MCLStore/terms.jsp



Looking for pricing, stock, or lifecycle information?

Click below to explore more details on WIN SOURCE:

 [View PMA3-313GLN+ on WIN SOURCE](#)

 [Mini-Circuits Information](#)

Optimize Your Supply Chain with WIN SOURCE Solutions

-  Global Sourcing Solution
-  Obsolete Management
-  Cost Control Management
-  Shortage Management
-  Alternative Solution
-  Excess Inventory Management