

PLG Radial Lead Type, Higher Capacitance

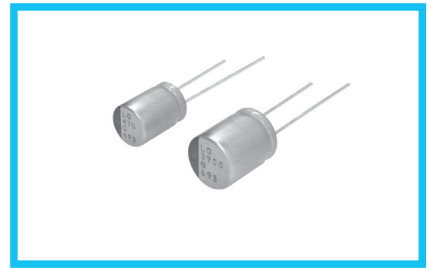

- Higher Capacitance, Low ESR, High ripple current.
- Load life of 2000 hours at 105°C.
- Radial lead type : Lead free flow soldering condition correspondence
- Compliant to the RoHS directive (2011/65/EU,(EU)2015/863).



PLG

Higher Capacitance
PLF

Products which are scheduled to be discontinued.
Not recommended for new designs.

Specifications

Item	Performance Characteristics		
Category Temperature Range	-55 to +105°C		
Rated Voltage Range	2.5 to 16V		
Rated Capacitance Range	330 to 3900µF		
Capacitance Tolerance	±20% at 120Hz, 20°C		
Tangent of loss angle (tan δ)	Less than or equal to the specified value at 120Hz, 20°C		
ESR (※ 1)	Less than or equal to the specified value at 100kHz, 20°C		
Leakage Current (※ 2)	Less than or equal to the specified value. After 2 minutes' application of rated voltage at 20°C		
Temperature Characteristics (Max.Impedance Ratio)	$Z(+105^{\circ}\text{C}) / Z(+20^{\circ}\text{C}) \leq 1.25$ (100kHz) $Z(-55^{\circ}\text{C}) / Z(+20^{\circ}\text{C}) \leq 1.25$		
Endurance	The specifications listed at right shall be met when the capacitors are restored to 20°C after the rated voltage is applied for 2000 hours at 105°C.	Capacitance change	Within ± 20% of the initial capacitance value (※ 3)
		tan δ	150% or less than the initial specified value
		ESR (※ 1)	150% or less than the initial specified value
		Leakage current (※ 2)	Less than or equal to the initial specified value
Damp Heat (Steady State)	The specifications listed at right shall be met when the capacitors are restored to 20°C after the rated voltage is applied for 1000 hours at 60°C, 90% RH.	Capacitance change	Within ± 20% of the initial capacitance value (※ 3)
		tan δ	150% or less than the initial specified value
		ESR (※ 1)	150% or less than the initial specified value
		Leakage current (※ 2)	Less than or equal to the initial specified value
Resistance to Soldering Heat	After soldering the capacitor under the soldering conditions prescribed here as preheat at 150 to 200°C for 60 to 180 seconds and peak temperature at 265°C for 10 seconds or less, the capacitor shall meet the specifications listed at right, provided that its temperature profile is measured at both of terminal ends facing the soldering side.	Capacitance change	Within ± 10% of the initial capacitance value (※ 3)
		tan δ	130% or less than the initial specified value
		ESR (※ 1)	130% or less than the initial specified value
		Leakage current (※ 2)	Less than or equal to the initial specified value
Marking	Navy blue print on the case top		

- ※ 1 ESR should be measured at both of the terminal ends closest to the capacitor body.
- ※ 2 Conditioning : If any doubt arises, measure the leakage current after the voltage treatment of applying DC rated voltage continuously to the capacitor for 120 minutes at 105°C.
- ※ 3 Initial value : The value before test of examination of resistance to soldering.

Dimensions

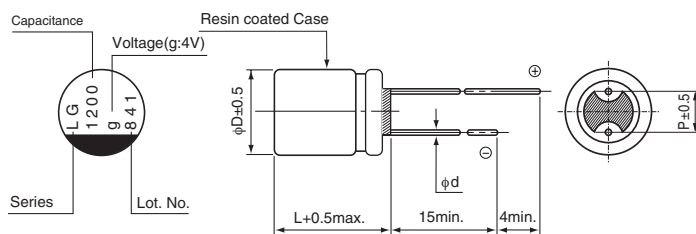

	(mm)		
Size	φ8 × 9L	φ8 × 12L	φ10 × 13L
φD	8.0	8.0	10.0
L	8.5	11.5	12.5
P	3.5	3.5	5.0
φd	0.6	0.6	0.6

Voltage	2.5	4	6.3	10	16
Code	e	g	j	A	C

Type numbering system (Example : 4V 1200µF)

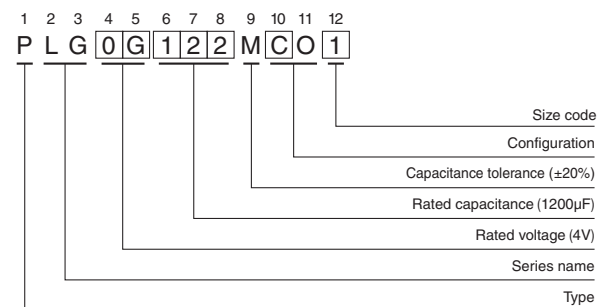

Frequency coefficient of rated ripple current

Frequency	120Hz	1kHz	10kHz	100kHz or more
Coefficient	0.05	0.30	0.70	1.00

Please refer to the Guidelines for Aluminum Electrolytic Capacitors for end seal configuration information.

• Dimension table in next page.

PLG

■ Dimensions

Rated Voltage (V) Code	Surge Voltage (V)	Rated Capacitance (μF)	Case Size φD × L (mm)	tan δ	Leakage Current (μA) (at 20°C after 2 minutes)	ESR (mΩ) (20°C/100kHz)	Rated Ripple (mA _{rms}) (105°C/100kHz)	Part Number
2.5 (0E)	2.8	1800	8 × 9	0.08	900	9	6000	PLG0E182MCO1
		2200	8 × 12	0.08	1100	8	6700	PLG0E222MDO1
		2700	10 × 13	0.08	1350	8	5560	PLG0E272MDO1
		3900	10 × 13	0.08	1950	8	7000	PLG0E392MDO1
4 (0G)	4.6	1200	8 × 9	0.08	960	9	5900	PLG0G122MCO1
		1800	8 × 12	0.08	1440	9	6500	PLG0G182MDO1
		2700	10 × 13	0.08	2160	8	6900	PLG0G272MDO1
6.3 (0J)	7.2	820	8 × 9	0.08	1033	9	5700	PLG0J821MCO1
		1200	8 × 12	0.08	1512	9	6100	PLG0J122MDO1
		1500	10 × 13	0.08	1890	9	6300	PLG0J152MDO1
		1800	10 × 13	0.08	2268	8	6600	PLG0J182MDO1
10 (1A)	11.5	560	8 × 9	0.08	1120	11	5100	PLG1A561MCO1
		820	8 × 12	0.08	1640	10	5800	PLG1A821MDO1
		1200	10 × 13	0.08	2400	9	6200	PLG1A122MDO1
16 (1C)	18.4	330	8 × 9	0.08	1056	13	4700	PLG1C331MCO1
		470	8 × 12	0.08	1504	11	5400	PLG1C471MDO1
		820	10 × 13	0.08	2624	11	5600	PLG1C821MDO1

• For formed lead or taped product specifications and minimum order quantity, please refer to the Guidelines for Aluminum Electrolytic Capacitors.







Looking for pricing, stock, or lifecycle information?

Click below to explore more details on WIN SOURCE:

 [View PLG1C821MDO1 on WIN SOURCE](#)

 [Nichicon Information](#)

Optimize Your Supply Chain with WIN SOURCE Solutions

-  Global Sourcing Solution
-  Obsolete Management
-  Cost Control Management
-  Shortage Management
-  Alternative Solution
-  Excess Inventory Management