



GRF6011
SPDT Failsafe Switch
0.01 to 6 GHz

FEATURES

Path: RFC to RF1: 1.9 GHz, $V_{DD} = 3.3\text{ V}$

- Insertion Loss: 0.43 dB
- IP1dB: 32 dBm
- IIP3: 49.5 dBm
- Failsafe Mode: High Loss

Path: RFC to RF2: 1.9 GHz, $V_{DD} = 3.3\text{ V}$

- Insertion Loss: 0.33 dB
- IP1dB: 30.5 dBm
- IIP3: 51 dBm
- Failsafe Mode: 0.4 dB Loss

APPLICATIONS

- Signal Boosters/Repeaters
- Tower Mounted Amplifiers
- ISM Radios
- Automotive Telematics
- RFID

DESCRIPTION

The GRF6011 is a linear, ultra-low loss SPDT Switch that has been designed with failsafe characteristics when all voltage inputs are removed. In switching mode, the device delivers IP1dB levels greater than 1 Watt along with >49 dBm IIP3 levels for both RF paths.

When powered down (failsafe mode) RFC to RF1 defaults to a high insertion loss while RFC to RF2 defaults to a low insertion loss state that retains high linearity.

With optimization of external components, the upper frequency range of the device can be extended to 6 GHz. Data plots using this high frequency tune are also included on the following pages. Optimization for a particular band essentially involves selecting the optimal series capacitor values (M1, M4, M5) for the three RF Ports.

The device is operated from a supply voltage of 3 volts to 5 volts with the single control input (V_{SELECT}) from 3 volts up to V_{DD} .

Please consult with the GRF applications engineering team for technical support.

BLOCK DIAGRAM

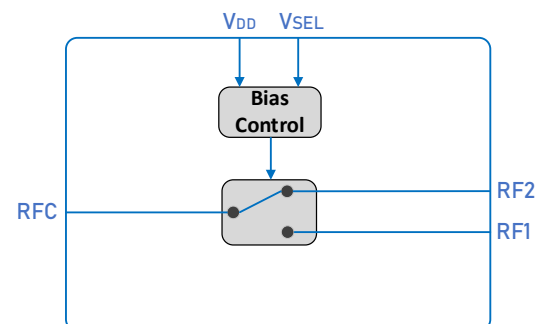

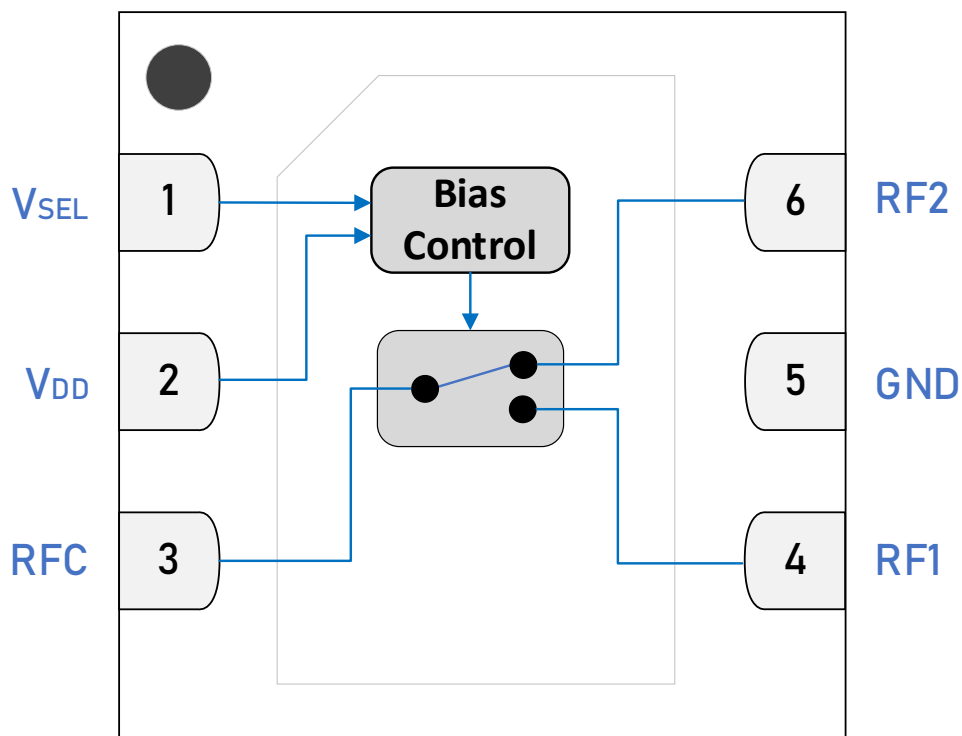

1.5 x 1.5mm DFN-6 Pin Out (Top View)

Pin Assignments

Pin	Name	Description	Note
1	V _{SELECT}	Switching Control Input	V _{SEL} voltage selects RF path.
2	V _{DD}	Supply Voltage Input	Supply voltage input from 3 to 5 V.
3	RFC	Common RF Path	An external DC blocking capacitor must be used.
4	RF1	RFC to RF1	This path defaults to high insertion loss when all power is removed. An external DC blocking capacitor must be used.
5	GND	Ground	No internal connection to die. We recommend connecting these pins to ground.
6	RF2	RFC to RF2	This path defaults to low insertion loss when all power is removed. An external DC blocking capacitor must be used.
PKG BASE	GND	Ground	Provides DC and RF ground as well as thermal heat sink. Recommend multiple 8 mil vias beneath the package for optimal RF and thermal performance. Refer to evaluation board top layer graphic on schematic page.

Power On/Off Sequence (V_{DD}/V_{SEL}/RF)

	V _{DD}	V _{SEL}	RF		RF	V _{SEL}	V _{DD}
POWER ON →	On →	On →	On	POWER OFF →	Off →	Off →	Off

NOTE: Voltage can be applied to and removed from V_{DD} and V_{SEL} simultaneously.

Control Logic Truth Table

Mode	Description	V _{DD}	V _{SEL}
RFC to RF1	Selects RF1	≥ 3 V	1
RFC to RF2	Selects RF2	≥ 3 V	0
Failsafe	No voltage input (RF2 path selected)	0 V or float	0 V or float
V _{SEL} Logic Level "0"	Logic Low	≥ 3 V	< 0.1 V
V _{SEL} Logic Level "1"	Logic High	≥ 3 V	3 V ≤ V _{SEL} ≤ V _{DD}

Absolute Ratings

Parameter	Symbol	Min.	Max.	Unit
Supply Voltage	V_{DD}	0	6	V
RF Input Power (average) VSWR: 1:1	$P_{IN\ MAX}$		36	dBm
Operating Temperature (package base)	$T_{PKG\ BASE}$	-40	105	°C
Maximum Channel Temperature	T_{MAX}		170	°C

Electrostatic Discharge

Human Body Model	HBM	175		V
------------------	-----	-----	--	---

Storage

Storage Temperature	T_{STG}	-65	150	°C
Moisture Sensitivity Level	MSL		1	–



Caution! ESD Sensitive Device

Exceeding Absolute Maximum Rating conditions may cause permanent damage to the device.

Note: For additional information, please refer to *Package Manufacturing Information* | *Guerrilla RF* (guerrilla-rf.com)



All Guerrilla RF products are provided in RoHS compliant lead (Pb)-free packaging requiring no exemptions. Additional information for this topic can be found at this link - *Environmental and Restricted Substance Statement Library*

Recommended Operating Conditions

Parameter	Symbol	Specification			Unit	Condition
		Min.	Typ.	Max.		
Supply Voltage	V_{DD}	0	3.3	6	V	
RF Frequency Range	F_{TEST}	0.01	1.9	6	GHz	Typical application schematic with external matching components (notes 1, 2).
Operating Temperature (package base)	$T_{PKG\ BASE}$	-40		105	°C	
RFIN Port Impedance	Z_{RFIN}		50		Ω	Single-ended.
RFOUT Port Impedance	Z_{RFOUT}		50		Ω	Single-ended.

Note 1: Operation outside this range is possible, but with degraded performance of some parameters.

Note 2: Contact the Guerrilla RF Applications team for guidance on optimizing the tuning of the device for alternative bands.

Nominal Operating Conditions

The following conditions apply unless noted otherwise: typical application schematic using the 0.1 to 6 GHz tuning set, 50 Ω system impedance, $V_{DD} = 3.3$ V, $V_{SEL} = 3.3$ V, $I_{DD} = 1000$ μ A, $F_{TEST} = 1.9$ GHz, $T_{PKG\ BASE} = 25$ $^{\circ}$ C. Evaluation board losses are included within the specifications.

Parameter	Symbol	Specification			Unit	Condition
		Min.	Typ.	Max.		
Switch Mode: RFC to RF1 Selected						
Loss (Package Device)	Loss_1		0.43		dB	$V_{DD} = 3.3$ V, $V_{SEL} = 3.3$ V, $T_A = 25^{\circ}$ C.
Isolation: RF1 to RF2	Isol_1_2		22		dB	
Input Power for 1 dB Compression	IP1dB_1		32		dBm	
Input 3rd Order Intercept Point	IIP3_1		49.5		dBm	
Supply Current	I_{DD}		1000		μ A	
V_{SEL} Current	I_{SELECT}		800		μ A	
Switch Mode: RFC to RF2 Selected						
Loss (Package Device)	Loss_2		0.33		dB	$V_{DD} = 3.3$ V, $V_{SEL} = 0$ V, $T_A = 25^{\circ}$ C.
Isolation: RF1 to RF2	Isol_1_2		25		dB	
Input Power for 1 dB Compression	IP1dB_2		30.5		dBm	
Input 3rd Order Intercept Point	IIP3_2		51		dBm	
Supply Current	I_{DD}		300		μ A	
V_{SEL} Current	I_{SELECT}		0		μ A	
Failsafe Mode: RFC to RF2 (default short)						
Loss	Loss_2		0.40		dB	$V_{DD} = 0$ V, $V_{SEL} = 0$ V, $T_A = 25^{\circ}$ C.
Isolation: RF1 to RF2	Isol_1_2		22		dB	
Input Power for 1 dB Compression	IP1dB_2		29		dBm	
Input 3rd Order Intercept Point	IIP3_2		48		dBm	
Failsafe Mode: RFC to RF1 (default open)						
Loss	Loss_1		23		dB	$V_{DD} = 0$ V, $V_{SEL} = 0$ V, $T_A = 25^{\circ}$ C.
Thermal Data						
Thermal Resistance: (Infrared Scan)	Θ_{JC}		TBD		$^{\circ}$ C/W	On standard evaluation board.

GRF6011 Switching Times

The following conditions apply unless noted otherwise: typical application schematic using the 0.1 to 6 GHz tuning set, 50 Ω system impedance, $V_{DD} = 3.3$ V, $V_{SEL} = 3.3$ V, $I_{DD} = 1000$ μ A, $F_{TEST} = 1.9$ GHz, $T_{PKG\ BASE} = 25$ °C. Evaluation board losses are included within the specifications.

Path	State	Freq (GHz)	V_{DD} (V)	V_{SEL} (V)	P_{IN} (dBm)	Time (ns)
Normal Mode						
RFC to RF1 (50% V_{SEL} to 90% RF1_Out)	On	1.9	3.3	0 \rightarrow 3.3	5	75
RFC to RF1 (50% V_{SEL} to 10% RF1_Out)	Off	1.9	3.3	3.3 \rightarrow 0	5	31
RFC to RF2 (50% V_{SEL} to 90% RF2_Out)	On	1.9	3.3	3.3 \rightarrow 0	5	82
RFC to RF2 (50% V_{SEL} to 10% RF2_Out)	Off	1.9	3.3	0 \rightarrow 3.3	5	79
Failsafe Mode						
Failsafe Off to Failsafe On	On	1.9	3.3 \rightarrow 0	3.3 \rightarrow 0	5	6000
Failsafe On to Failsafe Off	Off	1.9	0 \rightarrow 3.3	0 \rightarrow 3.3	5	600

Failsafe Characteristics: $V_{DD} = V_{SEL} = 0$ V

1. RFC to RF1 defaults to high insertion loss state.
2. RFC to RF2 defaults to low insertion loss state.

GRF6011 Typical Operating Curves: 3.3 V, 1000 μ A, 0.7 to 4 GHz Tune

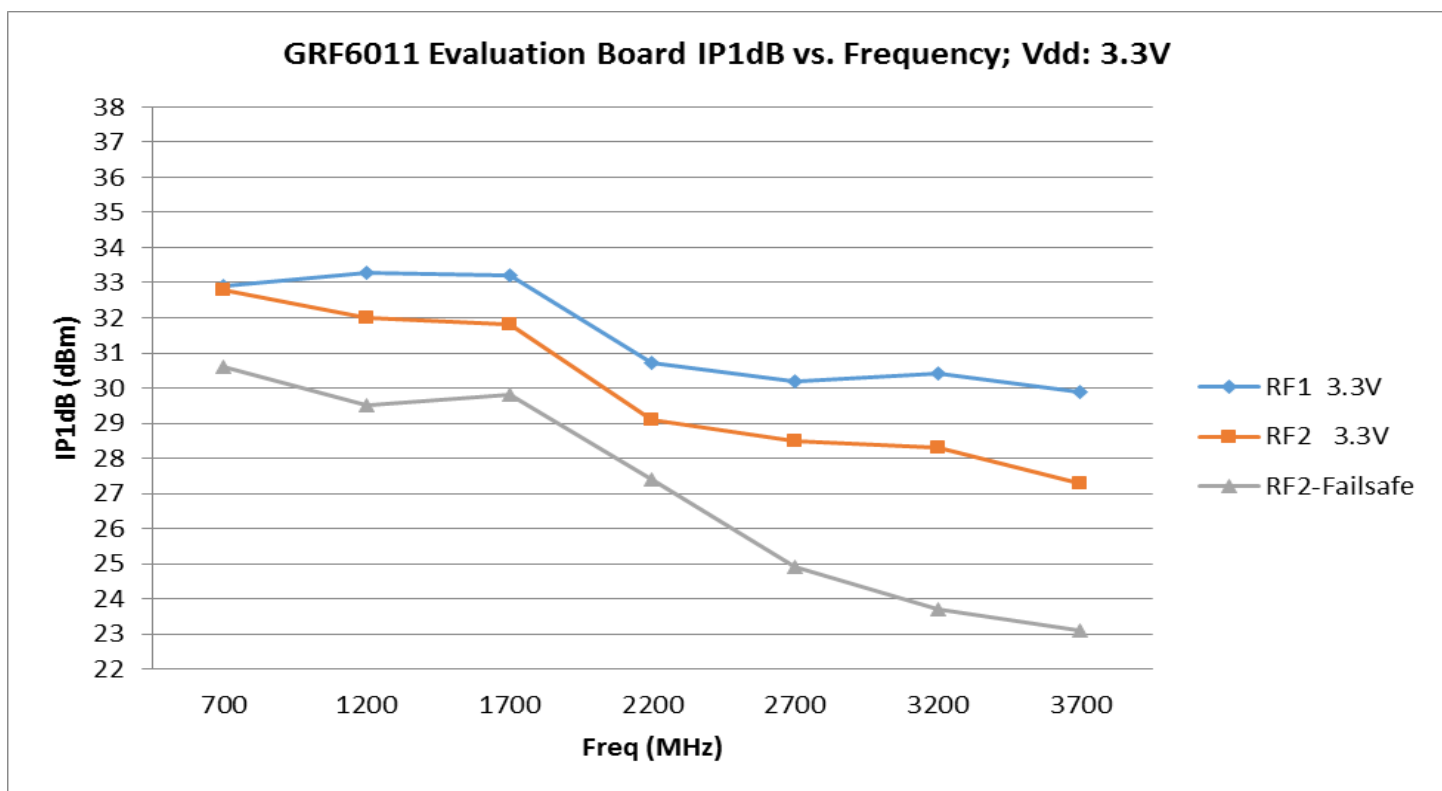
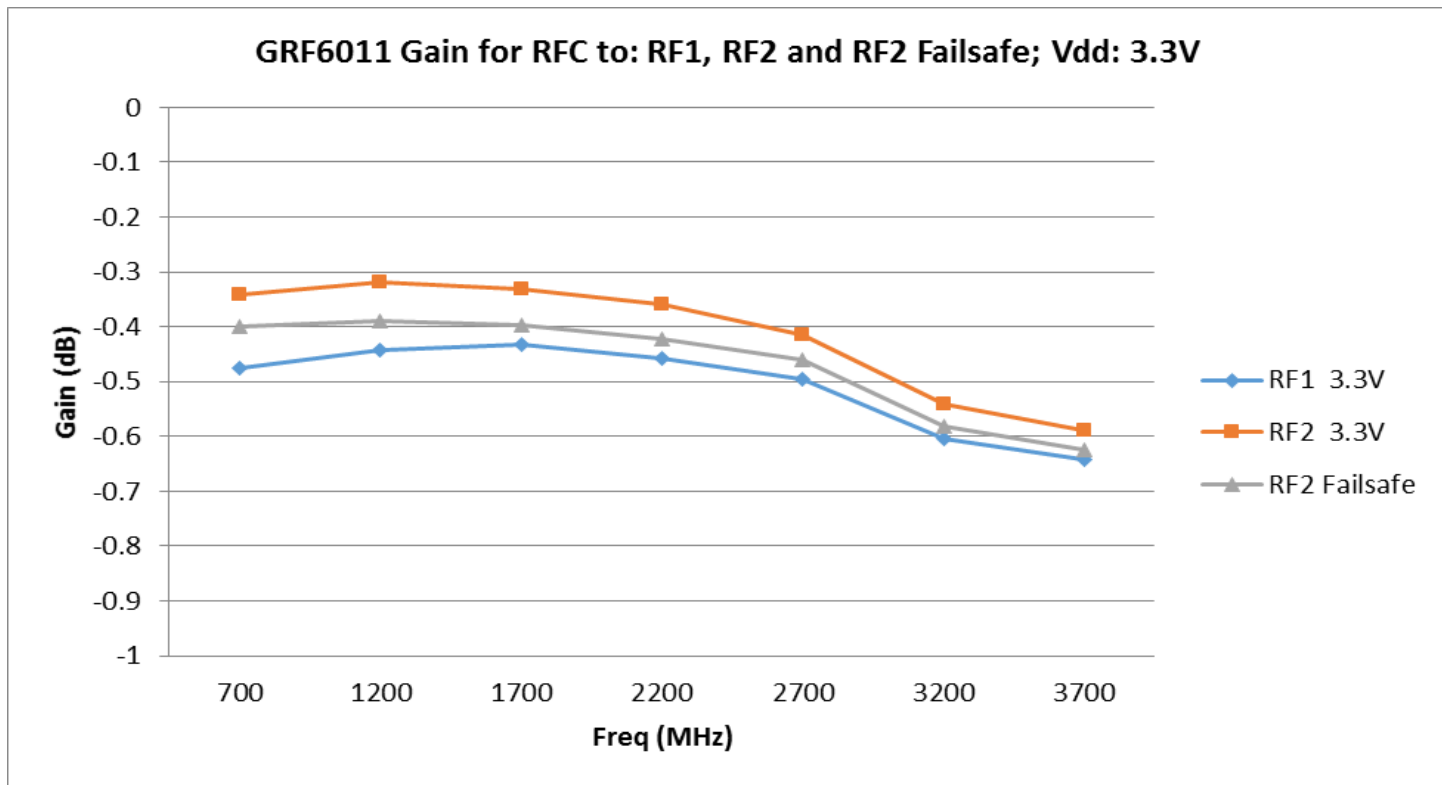

GRF6011 Typical Operating Curves: 3.3 V, 1000 μ A, 0.7 to 4 GHz Tune

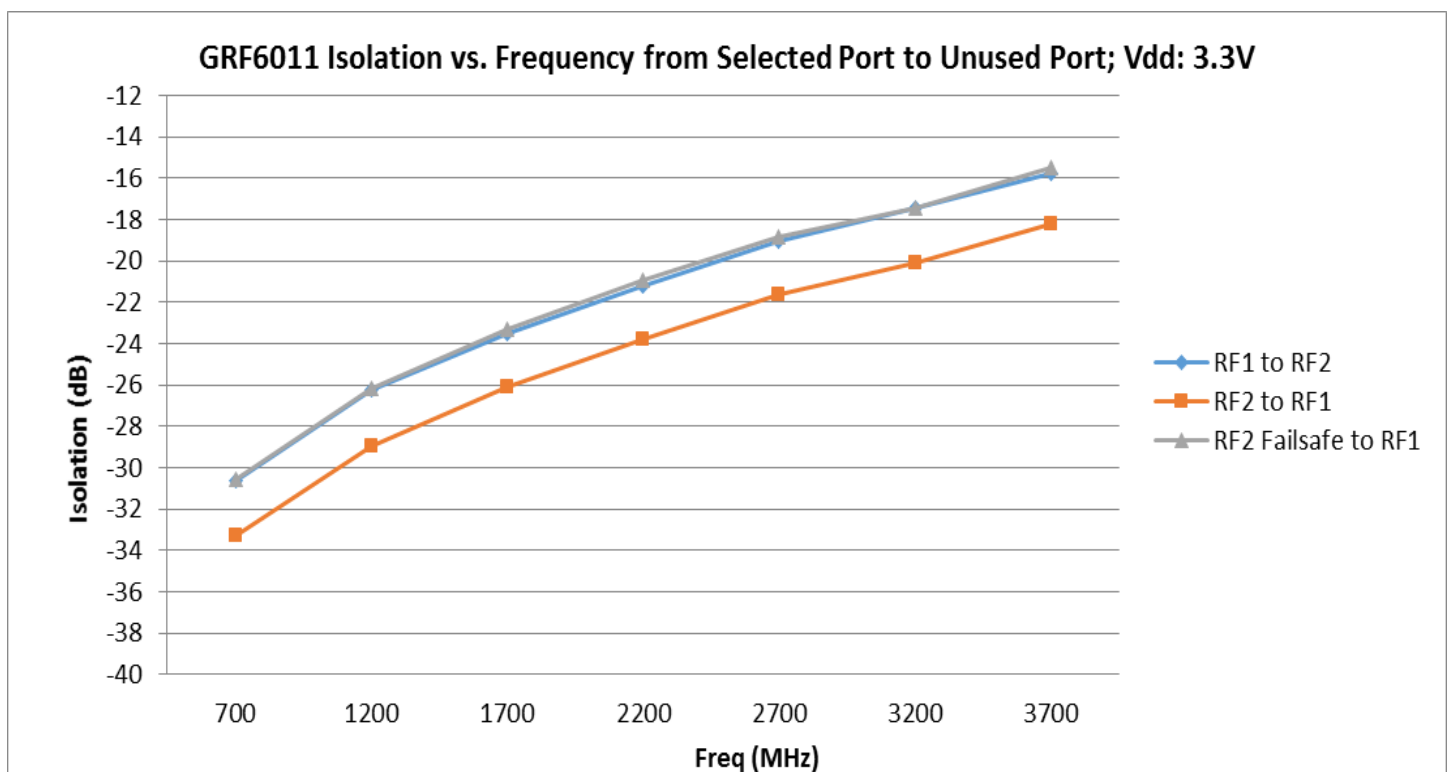
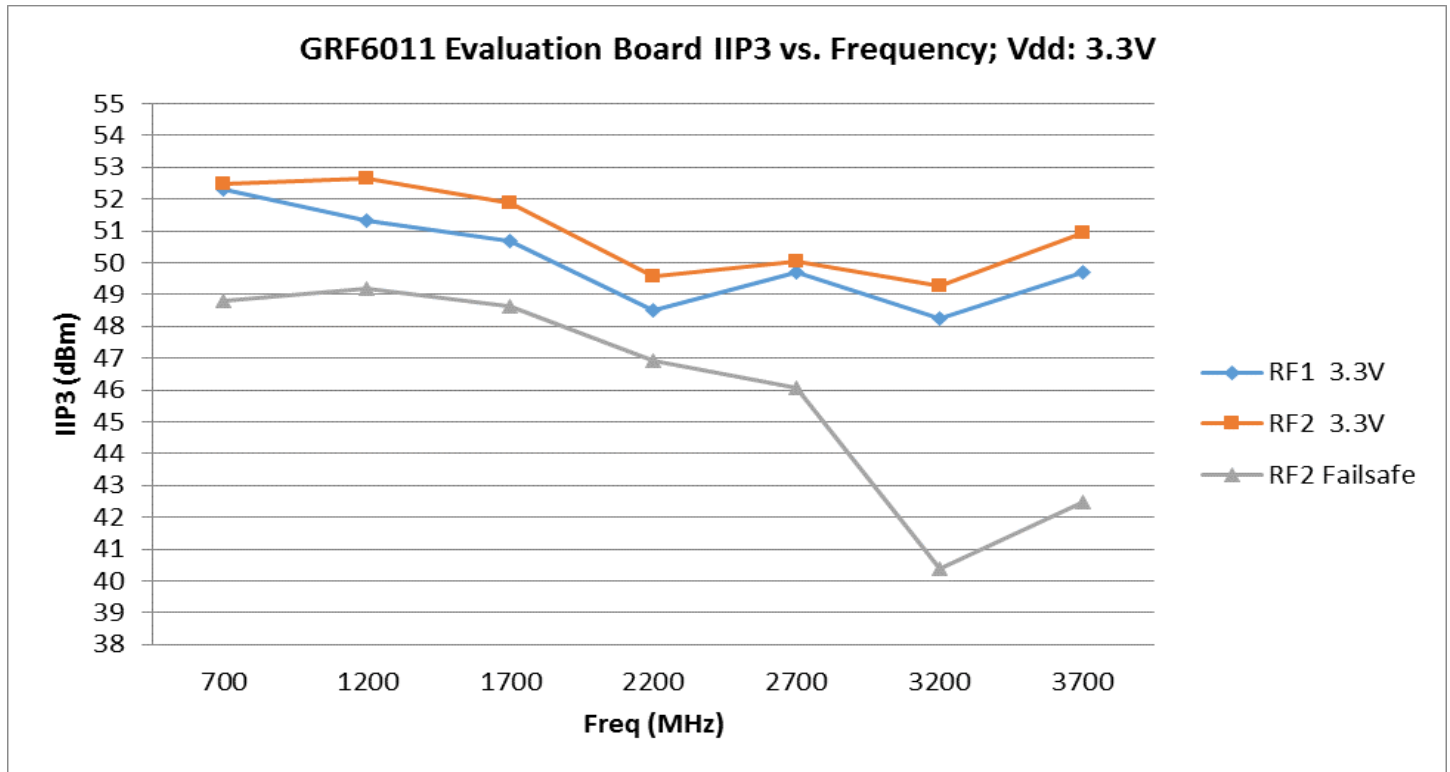

GRF6011 Typical Operating Curves: 3.3 V, 1000 μ A, 4 to 6 GHz Tune

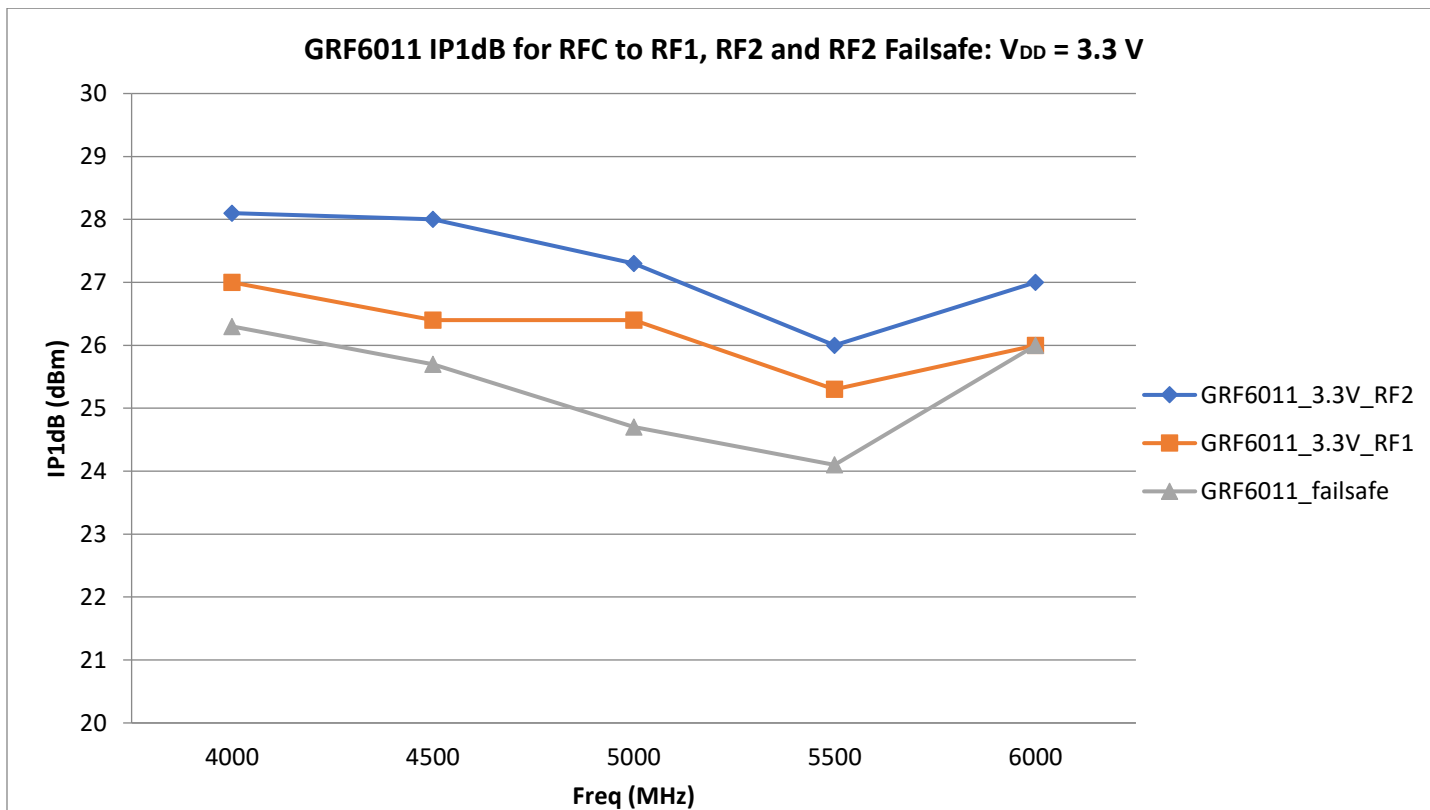
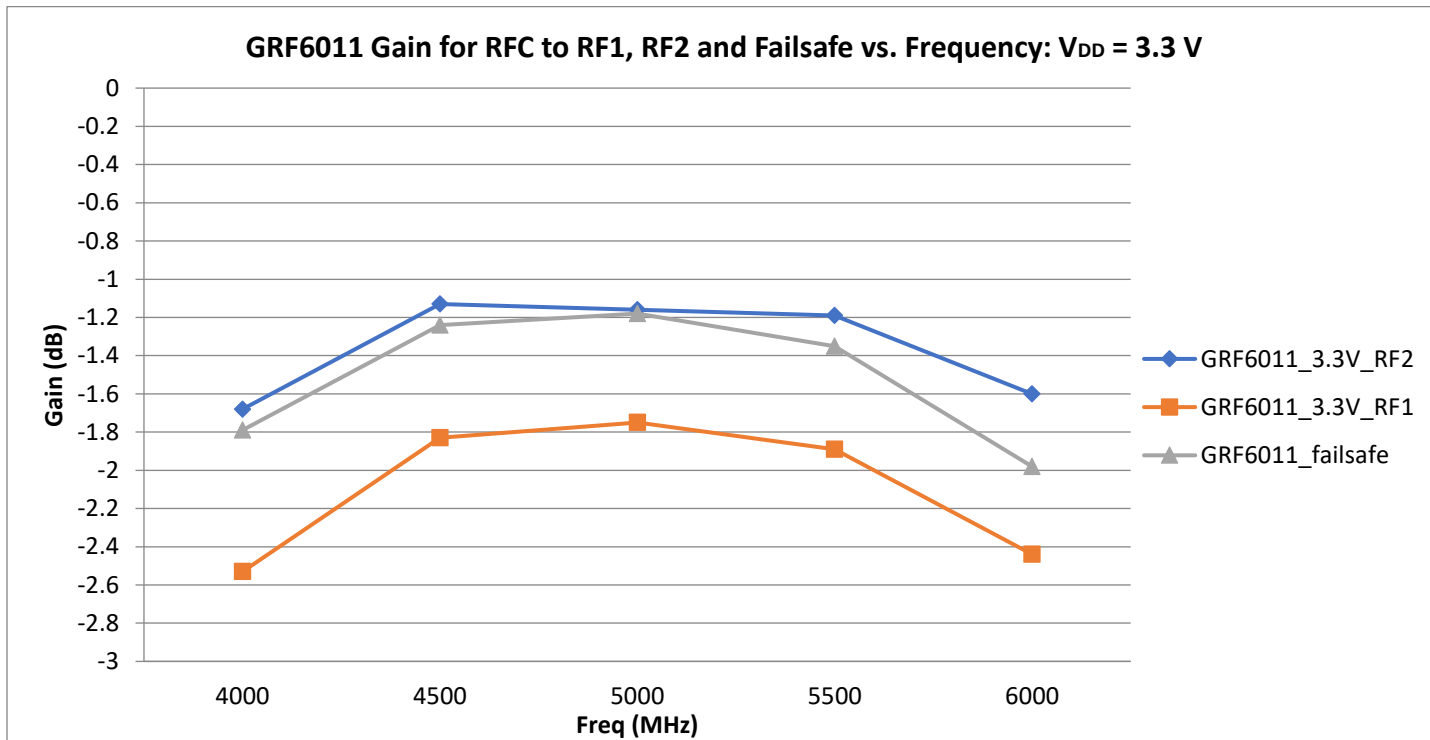

GRF6011 Typical Operating Curves: 3.3 V, 1000 μ A, 4 to 6 GHz Tune

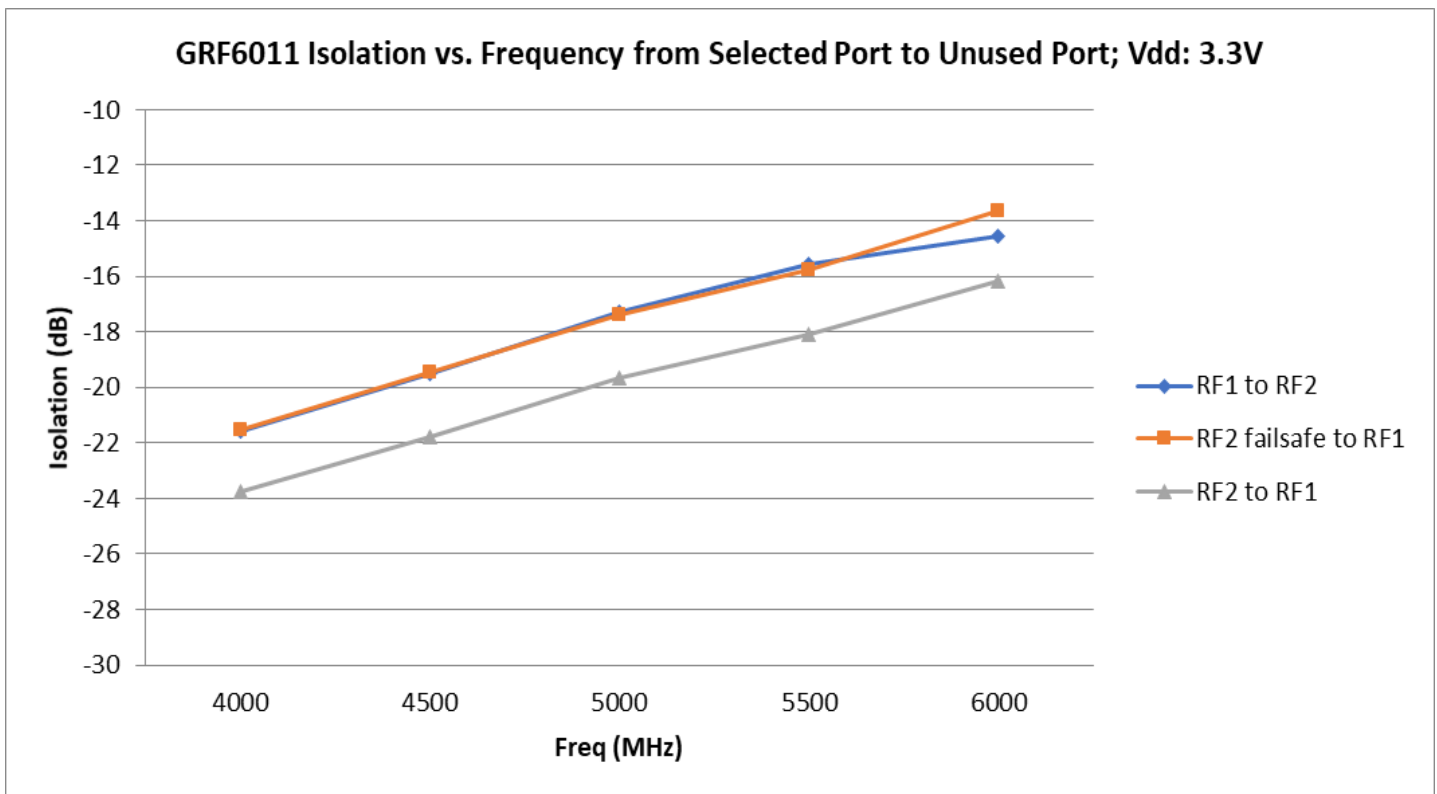
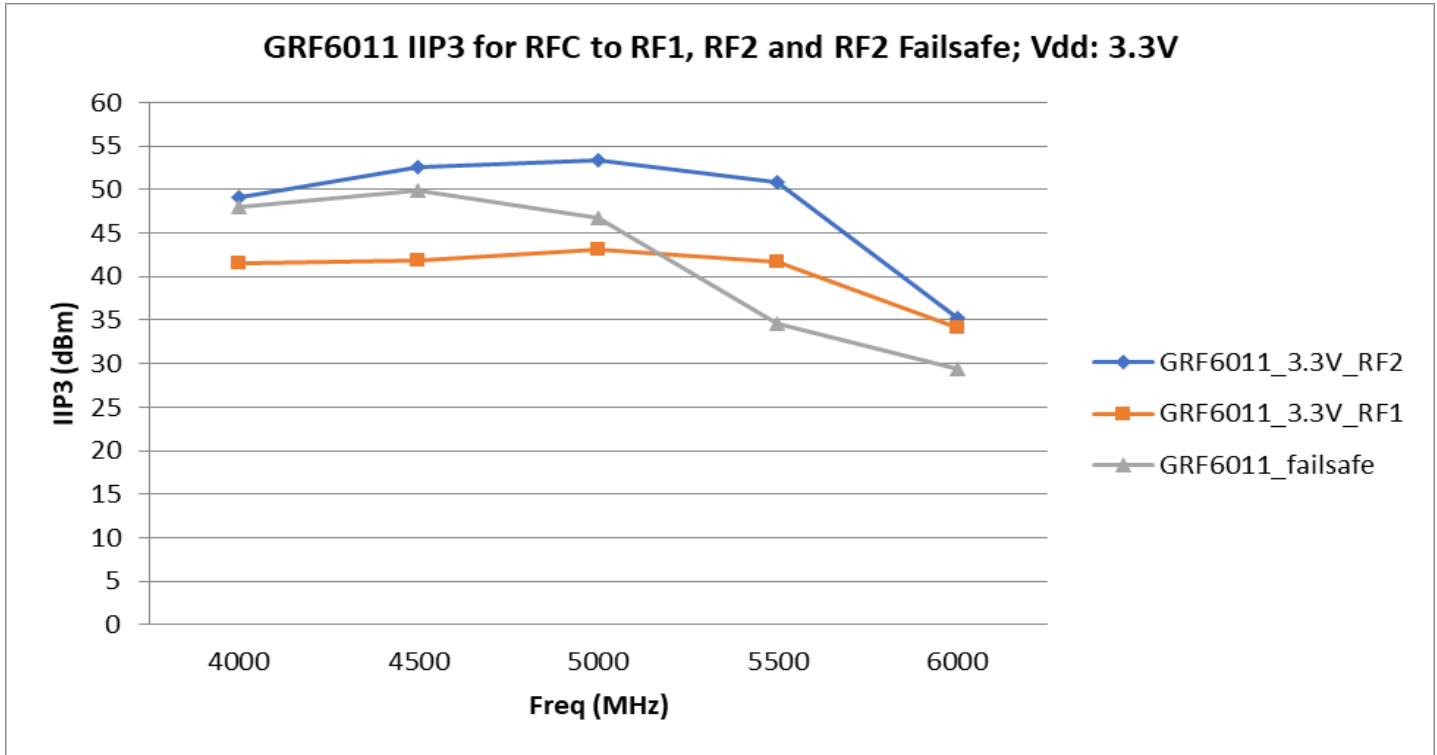

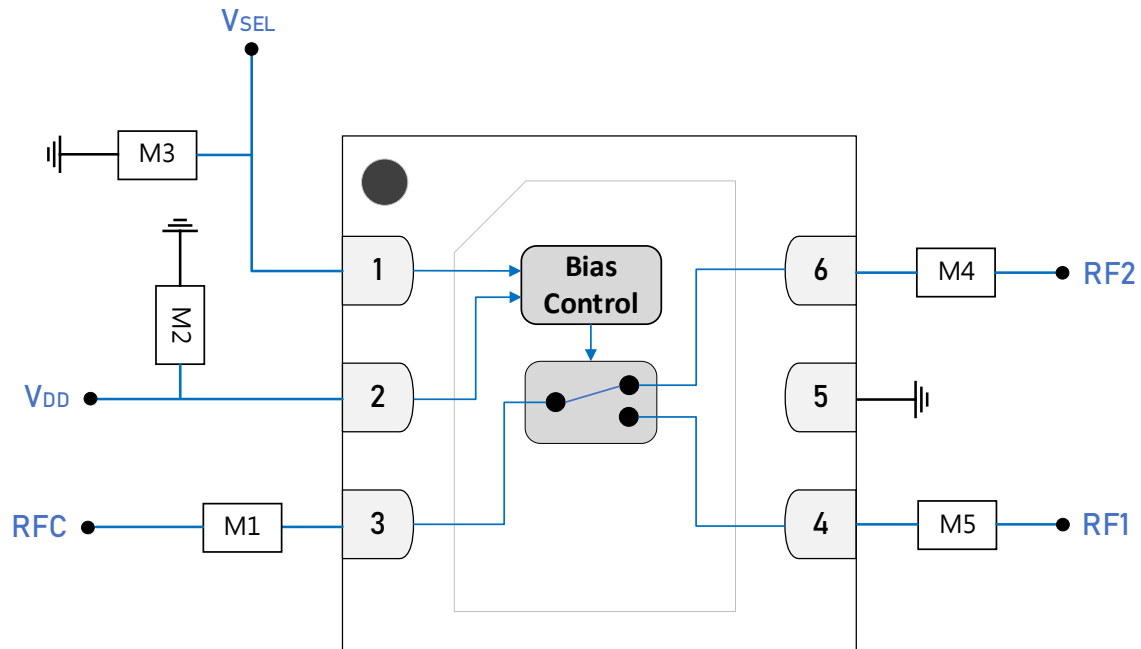

GRF6011 Standard Evaluation Board Schematic

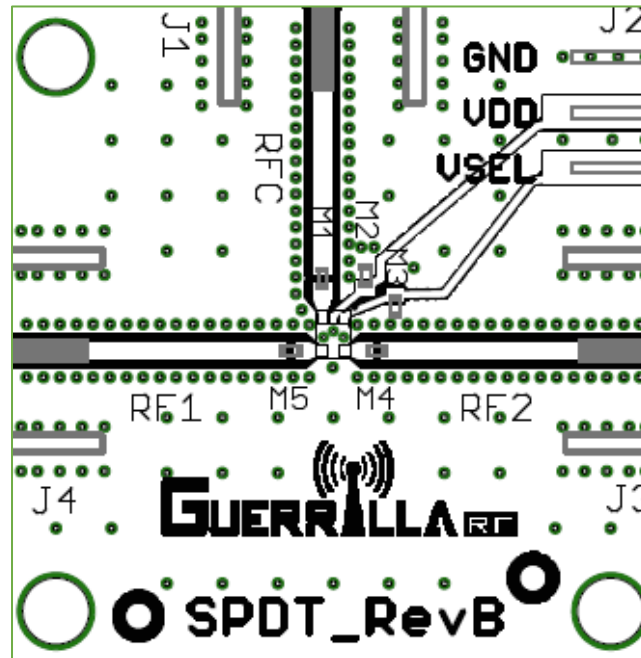

GRF6011 Evaluation Board Assembly Diagram

GRF6011 Standard Evaluation Board Assembly Diagram Reference: 0.4 to 4 GHz Tune

Component	Type	Manufacturer	Family	Value	Package Size	Substitution
M1	Capacitor	Murata	GJM	47 pF	0402	ok
M2	Capacitor	Murata	GRM	100 pF	0402	ok
M3	Capacitor	Murata	GRM	100 pF	0402	ok
M4	Capacitor	Murata	GJM	47 pF	0402	ok
M5	Capacitor	Murata	GJM	47 pF	0402	ok

GRF6011 Evaluation Board Assembly Diagram Reference: 4 to 6 GHz Tune

Component	Type	Manufacturer	Family	Value	Package Size	Substitution
M1	Capacitor	Murata	GJM	1.0 pF	0402	ok
M2	Capacitor	Murata	GRM	100 pF	0402	ok
M3	Capacitor	Murata	GRM	100 pF	0402	ok
M4	Capacitor	Murata	GJM	1.0 pF	0402	ok
M5	Capacitor	Murata	GJM	1.0 pF	0402	ok

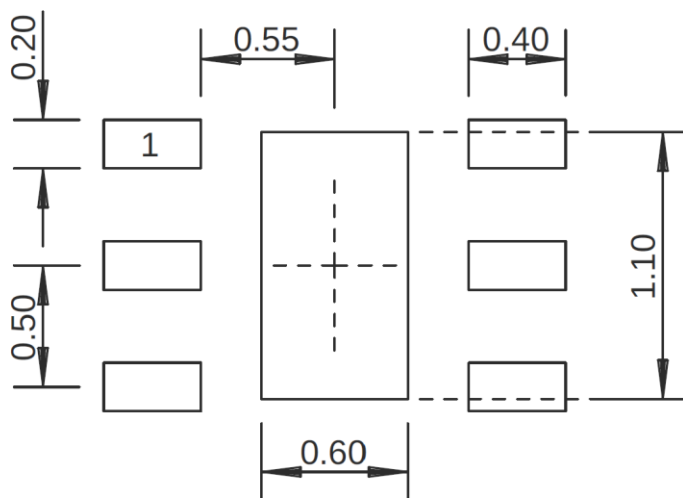

1.5 x 1.5 mm DFN-6 Suggested PCB Footprint (Top View)

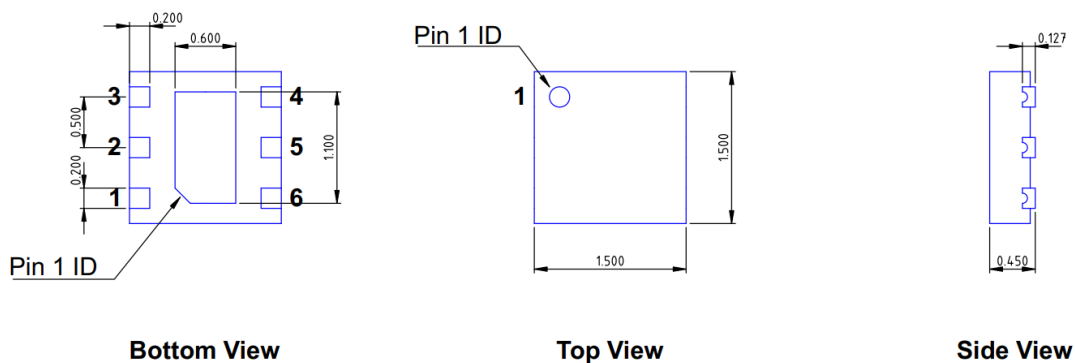

DFN6 1.5x1.5mm
 Dimensions in millimeters
 Dimensional Tolerance: ± 0.05

1.5 x 1.5 mm DFN-6 Package Dimensions

Package Marking Diagram

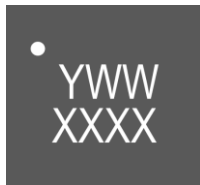

- Line 1: "Y" = YEAR (single digit). "WW" = WEEK the Device was assembled.
- Line 2: "XXXX" = Device Part Number.

Tape and Reel Information

Guerrilla RF's tape and reel specification complies with Electronics Industries Alliance (EIA) standards for "Embossed Carrier Tape of Surface Mount Components for Automatic Handling" (reference EIA-481). See the following page for the Tape and Reel Specification and Device Package Information table, which includes units per reel.

Devices are loaded with pins down into the carrier pocket with protective cover tape and reeled onto a plastic reel. Each reel is packaged in a cardboard box. There are product labels on the reel, the protective ESD bag and the outside surface of the box.

For the Tape and Reel Reference Table, please refer to: [Package Manufacturing Information | Guerrilla RF \(guerrilla-rf.com\)](#)

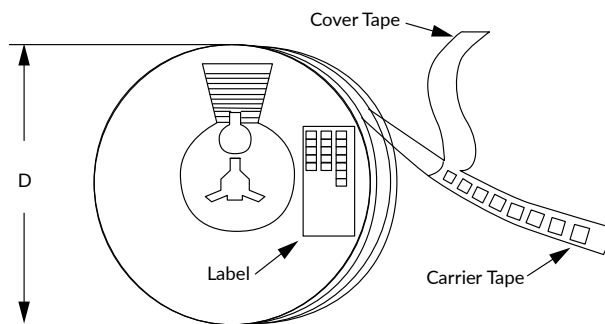

Tape and Reel Packaging with Reel Diameter Noted (D)

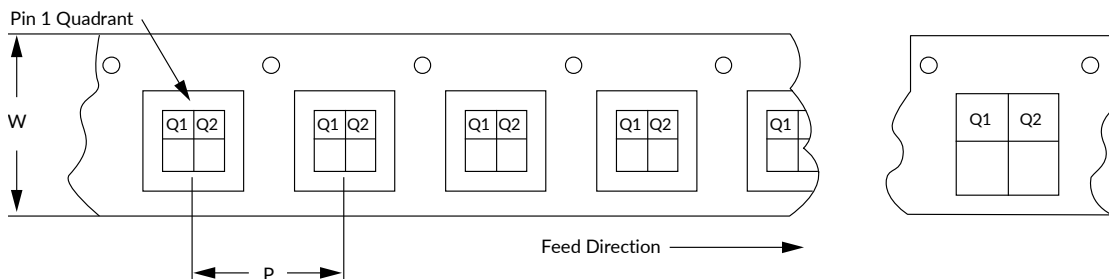

Carrier Tape Width (W), Pitch (P), Feed Direction and Pin 1 Quadrant Information



Revision History

Revision Date	Description of Change
January 13, 2017	Preliminary Data Sheet.
June 23, 2025	Converted Data Sheet to new format only (no change to device or device specifications). Extended lower frequency range from 100 MHz to 10 MHz.



Data Sheet Classifications

Data Sheet Status	Notes
Advance	S-parameter and NF data based on EM simulations for the fully packaged device using foundry-supplied transistor S-parameters. Linearity estimates based on device size, bias condition and experience with related devices.
Preliminary	All data based on limited evaluation board measurements taken within the Guerrilla RF Applications Lab. All parametric values are subject to change pending the collection of additional data.
Release Ø	All data based on measurements taken with <i>production-released</i> material. TYP values are based on a combination of ATE and bench-level measurements, with MIN/MAX limits defined using <i>modelled estimates</i> that account for part-to-part variations and expected process spreads. Although unlikely, future refinements to the TYP/MIN/MAX values may be in order as multiple lots are processed through the factory.
Release A-Z	All data based on measurements taken with production-released material <i>derived from multiple lots which have been fabricated over an extended period of time</i> . MIN/MAX limits may be refined over previous releases as more statistically significant data is collected to account for process spreads.

Information in this data sheet is specific to the Guerrilla RF, Inc. ("Guerrilla RF") product identified.

This data sheet, including the information contained in it, is provided by Guerrilla RF as a service to its customers and may be used for informational purposes only by the customer. Guerrilla RF assumes no responsibility for errors or omissions on this data sheet or the information contained herein. Information provided is believed to be accurate and reliable, however, no responsibility is assumed by Guerrilla RF for its use, nor for any infringement of patents, or other rights of third parties, resulting from its use. Guerrilla RF assumes no liability for any data sheet, data sheet information, materials, products, product information, or other information provided hereunder, including the sale, distribution, reproduction or use of Guerrilla RF products, information, or materials.

No license, whether express, implied, by estoppel, by implication or otherwise is granted by this data sheet for any intellectual property of Guerrilla RF, or any third party, including without limitation, patents, patent rights, copyrights, trademarks, and trade secrets. All rights are reserved by Guerrilla RF.

All information herein, products, product information, data sheets, and data sheet information are subject to change and availability without notice. Guerrilla RF reserves the right to change component circuitry, recommended application circuitry and specifications at any time without prior notice. Guerrilla RF may further change its data sheet, product information, documentation, products, services, specifications, or product descriptions at any time, without notice. Guerrilla RF makes no commitment to update any materials or information and shall have no responsibility whatsoever for conflicts, incompatibilities, or other difficulties arising from any future changes.

GUERRILLA RF INFORMATION, PRODUCTS, PRODUCT INFORMATION, DATA SHEETS AND DATA SHEET INFORMATION ARE PROVIDED "AS IS" AND WITHOUT WARRANTY OF ANY KIND, WHETHER EXPRESS, IMPLIED, STATUTORY, OR OTHERWISE, INCLUDING FITNESS FOR A PARTICULAR PURPOSE OR USE, MERCHANTABILITY, PERFORMANCE, QUALITY OR NON-INFRINGEMENT OF ANY INTELLECTUAL PROPERTY RIGHT; ALL SUCH WARRANTIES ARE HEREBY EXPRESSLY DISCLAIMED. GUERRILLA RF DOES NOT WARRANT THE ACCURACY OR COMPLETENESS OF THE INFORMATION, TEXT, GRAPHICS OR OTHER ITEMS CONTAINED WITHIN THESE MATERIALS. GUERRILLA RF SHALL NOT BE LIABLE FOR ANY DAMAGES, INCLUDING BUT NOT LIMITED TO ANY SPECIAL, INDIRECT, INCIDENTAL, STATUTORY, OR CONSEQUENTIAL DAMAGES, INCLUDING WITHOUT LIMITATION, LOST REVENUES OR LOST PROFITS THAT MAY RESULT FROM THE USE OF THE MATERIALS OR INFORMATION, WHETHER OR NOT THE RECIPIENT OF MATERIALS HAS BEEN ADVISED OF THE POSSIBILITY OF SUCH DAMAGE.

Customers are solely responsible for their use of Guerrilla RF products in the Customer's products and applications or in ways which deviate from Guerrilla RF's published specifications, either intentionally or as a result of design defects, errors, or operation of products outside of published parameters or design specifications. Customers should include design and operating safeguards to minimize these and other risks. Guerrilla RF assumes no liability or responsibility for applications assistance, customer product design, or damage to any equipment resulting from the use of Guerrilla RF products outside of stated published specifications or parameters.

Looking for pricing, stock, or lifecycle information?

Click below to explore more details on WIN SOURCE:

 [View GRF6011 on WIN SOURCE](#)

 [Guerrilla RF, Inc. Information](#)

Optimize Your Supply Chain with WIN SOURCE Solutions

-  Global Sourcing Solution
-  Obsolete Management
-  Cost Control Management
-  Shortage Management
-  Alternative Solution
-  Excess Inventory Management