

FEATURES

Analog input

- Worldwide NTSC/PAL/SECAM color demodulation support with autodetection
- One 10-bit ADC, 4x oversampling for CVBS, Y/C, and YPbPr
- 8 analog video input channels with on-chip antialiasing filter
- Fully differential, pseudo differential, and single-ended CVBS video input support
- STB diagnostics on differential video inputs
- CVBS (composite), Y/C (S-Video), and YPbPr (component) video input support
- Fast switching capability between analog inputs
- Adaptive contrast enhancement (ACE)
- Excellent common-mode noise rejection capabilities
- Rovi (Macrovision) copy protection detection
- Up to 4 V common-mode input range solution
- Vertical blanking interval (VBI) data slicer
- Mobile High-Definition Link (MHL) capable receiver
- High-bandwidth Digital Content Protection (HDCP) authentication and decryption support
- 75 MHz maximum pixel clock frequency, allowing HDTV formats up to 720p/1080i at 60 Hz
- 24 bits per pixel mode supported
- HDCP repeater support, up to 25 KSVs supported
- Adaptive TMDS equalizer
- High-Definition Multimedia Interface (HDMI) capable receiver
- HDCP authentication and decryption support
- 162 MHz maximum pixel clock frequency, allowing HDTV formats up to 1080p and display resolutions up to UXGA (1600 x 1200 at 60 Hz)
- HDCP repeater support, up to 25 KSVs supported
- Integrated CEC controller, CEC 1.4 compatible

Adaptive TMDS equalizer

5 V detect and Hot Plug assert

Component video processor

- Any-to-any 3 x 3 color space conversion (CSC) matrix
- Contrast/brightness/hue/saturation video adjustment
- Timing adjustments controls for horizontal sync (HS)/vertical sync (VS)/data enable (DE) timing
- Video mute function

Serial digital audio output interface

- HDMI/MHL audio extraction support
- Advanced audio muting feature
- I²S-compatible, left justified, and right justified audio output modes

8-channel TDM output mode available

2 Mobile Industry Processor Interface (MIPI) Camera Serial Interface 2 (CSI-2) transmitters

- 4-lane transmitter with 4 lanes, 2 lanes, and 1 lane muxing options for HDMI/MHL/SDP/digital input port sources
- 1-lane transmitter for standard definition processor (SDP) sources

8-bit digital input/output port

General

- 2-wire serial microprocessor unit (MPU) interface (I²C compatible)
- 40°C to +85°C temperature grade
- 100-ball, 9 mm x 9 mm, RoHS-compliant CSP_BGA package
- Qualified for automotive applications

APPLICATIONS

- Portable devices
- Automotive infotainment (head unit and rear seat entertainment systems)
- HDMI repeaters and video switches

FUNCTIONAL BLOCK DIAGRAM

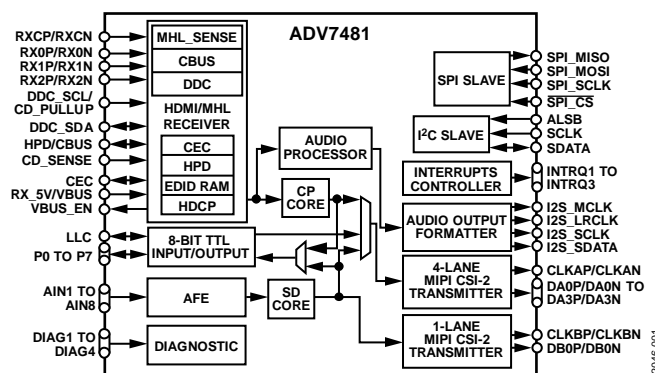

Figure 1.

Rev. 0

Document Feedback

Information furnished by Analog Devices is believed to be accurate and reliable. However, no responsibility is assumed by Analog Devices for its use, nor for any infringements of patents or other rights of third parties that may result from its use. Specifications subject to change without notice. No license is granted by implication or otherwise under any patent or patent rights of Analog Devices. Trademarks and registered trademarks are the property of their respective owners.

TABLE OF CONTENTS

Features	1	Power-Down Sequence.....	17
Applications.....	1	Theory of Operation	18
Functional Block Diagram	1	Combined HDMI/MHL Receiver.....	18
Revision History	2	MHL Receiver	18
General Description	3	HDMI Receiver.....	18
Detailed Functional Block Diagram	4	Component Processor	19
Specifications.....	5	Analog Front End.....	19
Electrical Characteristics.....	5	Short to Battery Diagnostics	19
Analog Video Specifications	7	Standard Definition Processor	20
MIPI Video Output Specifications.....	8	8-Bit Digital Input/Output Port	20
Analog Specifications.....	8	Audio Processing.....	21
Timing Specifications	9	MIPI CSI-2 Transmitters.....	21
Absolute Maximum Ratings.....	13	Interrupts.....	21
Thermal Resistance	13	Outline Dimensions	22
ESD Caution.....	13	Ordering Guide	22
Pin Configuration and Function Descriptions.....	14	Automotive Products.....	22
Power Supply Recommendation	17		
Power-Up Sequence	17		

REVISION HISTORY

6/14—Revision 0: Initial Version

GENERAL DESCRIPTION

The [ADV7481](#) is an integrated video decoder and combined HDMI®/MHL® receiver. It is targeted at connectivity enabled head units requiring a wired, uncompressed digital audio/video link from smartphones and other consumer electronics devices to support streaming and integration of cloud-based multimedia content and applications into an automotive infotainment system.

The [ADV7481](#) MHL 2.1 capable receiver supports a maximum pixel clock frequency of 75 MHz, allowing resolutions up to 720p/1080i at 60 Hz in 24-bit mode. The [ADV7481](#) features a link control bus (CBUS) that handles the link layer, translation layer, CBUS electrical discovery, and display data channel (DDC) commands. The implementation of the MHL sideband channel (MSC) commands by the system processor can be handled either by the I²C bus, or via a dedicated serial peripheral interface (SPI) bus. A dedicated interrupt pin (INTRQ3) is available to indicate that events related to CBUS have occurred.

The [ADV7481](#) also features an enable pin (VBUS_EN) to dynamically enable or disable the output of a voltage regulator, which provides a 5 V voltage bus (VBUS) signal to the MHL source.

The [ADV7481](#) HDMI capable receiver supports a maximum pixel clock frequency of 162 MHz, allowing HDTV formats up to 1080p, and display resolutions up to UXGA (1600 × 1200 at 60 Hz). The device integrates a consumer electronics control (CEC) controller that supports the capability discovery and control (CDC) feature. The HDMI input port has dedicated 5 V detect and Hot Plug™ assert pins.

The HDMI/MHL receiver includes an adaptive transition minimized differential signaling (TMDS) equalizer that ensures robust operation of the interface with long cables.

The [ADV7481](#) single receiver port is capable of accepting both HDMI and MHL electrical signals. Automatic detection between HDMI and MHL is achieved by using cable impedance detection through the CD_SENSE pin.

The [ADV7481](#) contains a component processor (CP) that processes the video signals from the HDMI/MHL receiver. It provides features such as contrast, brightness, and saturation adjustments, as well as free run and timing adjustment controls for HS/VS/DE timing.

The [ADV7481](#) analog front end (AFE) comprises a single high speed, 10-bit analog-to-digital converter (ADC) that digitizes the analog video signal before applying it to the SDP.

The eight analog video inputs can accept single-ended, pseudo differential, and fully differential composite video signals, as

well as S-Video and YPbPr video signals, supporting a wide range of consumer and automotive video sources.

Short to battery (STB) events can be detected on differential input video signals. STB protection is provided by ac coupling the input video signals. The [ADV7481](#), in combination with an external resistor divider, provides a common-mode input range of 4 V, enabling the removal of large signal common-mode transients present on the video lines.

The automatic gain control (AGC) and clamp restore circuitry allow an input video signal up to 1.0 V p-p at the analog video input pins of the [ADV7481](#). Alternatively, the AGC and clamp restore circuitry can be bypassed for manual settings.

The SDP of the [ADV7481](#) is capable of decoding a large selection of analog baseband video signals in composite, S-Video, and component formats. The SDP supports world-wide NTSC, PAL, and SECAM standards.

The [ADV7481](#) features an 8-bit digital input/output port, supporting input and output video resolutions up to 720p/1080i in both the 8-bit interleaved 4:2:2 SDR and DDR modes.

To enable glueless interfacing of these video input sources to the latest generation of infotainment system on chips (SoCs), the [ADV7481](#) features two MIPI® CSI-2 transmitters. The four-lane transmitter provides four data lanes, two data lanes, and one data lane muxing options, and can be used to output video from the HDMI receiver, the MHL receiver, the SDP, and the digital input port. The single-lane transmitter can be used to output video from the SDP only.

The [ADV7481](#) offers a flexible audio output port for audio data extracted from the MHL or HDMI streams. The HDMI/MHL receiver has advanced audio functionality, such as a mute controller that prevents audible extraneous noise in the audio output. Additionally, the [ADV7481](#) can be set to output time division multiplexing (TDM) serial audio, which allows the transmission of eight multiplexed serial audio channels on a single audio output interface port.

The [ADV7481](#) is programmed via a 2-wire, serial, bidirectional port (I²C compatible).

Fabricated in an advanced CMOS process, the [ADV7481](#) is available in a 9 mm × 9 mm, RoHS-compliant, 100-ball CSP_BGA package and is specified over the -40°C to +85°C temperature range.

The [ADV7481](#) is offered in automotive and industrial versions.

DETAILED FUNCTIONAL BLOCK DIAGRAM

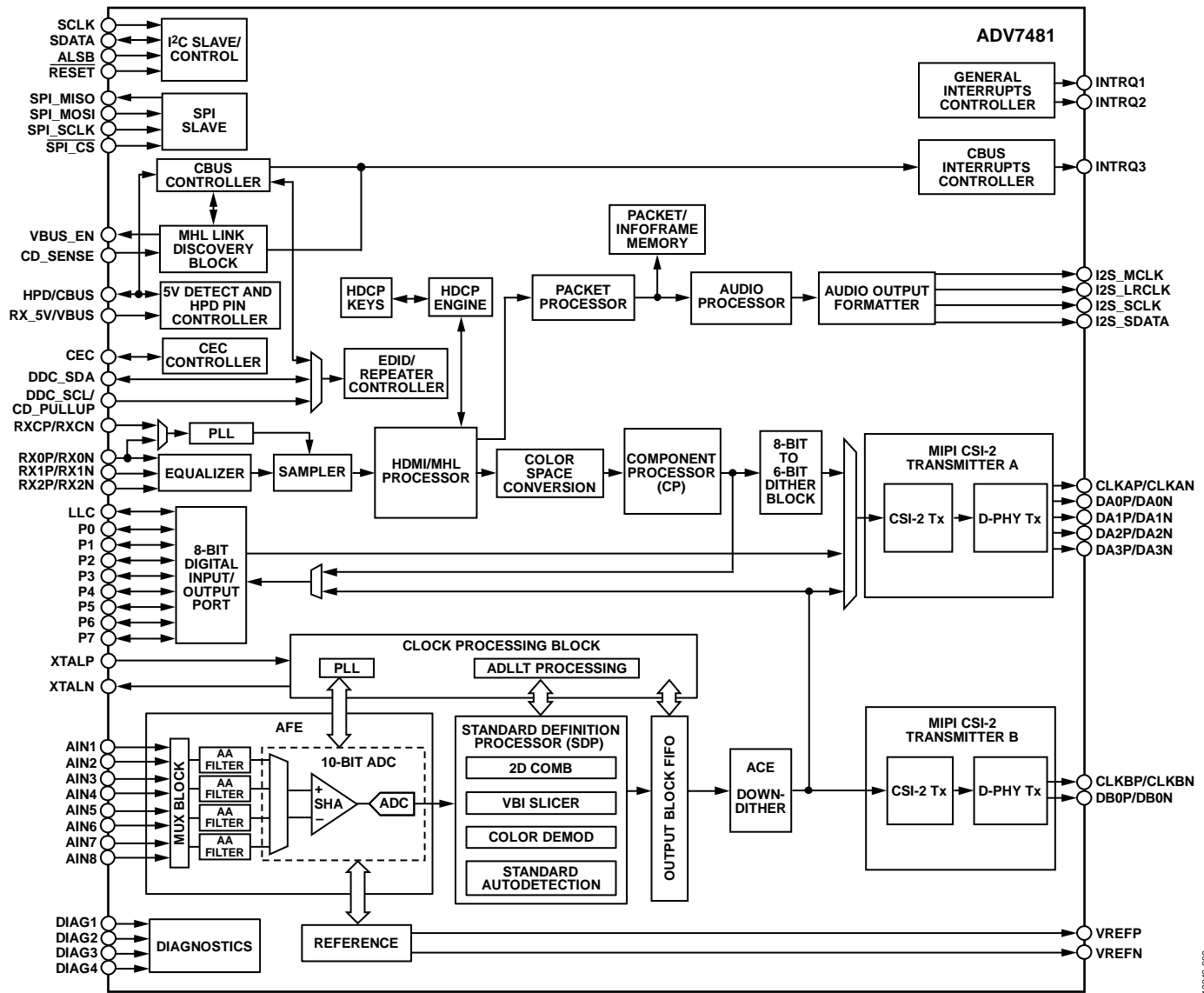

Figure 2.

12046-002

SPECIFICATIONS

ELECTRICAL CHARACTERISTICS

AVDD = 1.71 V to 1.89 V, DVDD = 1.71 V to 1.89 V, PVDD = 1.71 V to 1.89 V, MVDD = 1.71 V to 1.89 V, CVDD = 1.71 V to 1.89 V, DVDDIO = 3.14 V to 3.46 V, and TVDD = 3.14 V to 3.46 V, specified at operating temperature range, unless otherwise noted.

Table 1.

Parameter	Symbol	Test Conditions/Comments	Min	Typ	Max	Unit
STATIC PERFORMANCE						
Resolution (Each ADC)	N				10	Bits
Integral Nonlinearity	INL	CVBS mode		2		LSB
Differential Nonlinearity	DNL	CVBS mode		±0.6		LSB
DIGITAL INPUTS ¹						
Input High Voltage	V _{IH}	SCLK, SDATA, RESET, ALSB, SPI_CS, SPI_SCLK, SPI_MOSI, LLC, and P0 to P7 DVDDIO = 3.14 V to 3.46 V	2			V
Input Low Voltage	V _{IL}	DVDDIO = 3.14 V to 3.46 V			0.8	V
Input Leakage Current	I _{IN}		-10		+10	μA
Input Capacitance ²	C _{IN}				10	pF
CRYSTAL INPUT						
Input High Voltage	V _{IH}	XTALP	1.2			V
Input Low Voltage	V _{IL}	XTALP			0.4	V
DIGITAL OUTPUTS ¹						
Output High Voltage	V _{OH}	LLC, P0 to P7, I2S_MCLK, I2S_SCLK, I2S_LRCLK, I2S_SDATA, SPI_MISO, SDATA, INTRQ1 to INTRQ3 (when configured to drive when active), and VBUS_EN DVDDIO = 3.14 V to 3.46 V and I _{SOURCE} = 0.4 mA	2.4			V
Output Low Voltage	V _{OL}	DVDDIO = 3.14 V to 3.46 V and I _{SINK} = 3.2 mA			0.4	V
High Impedance Leakage Current	I _{LEAK}			10		μA
Output Capacitance ²	C _{OUT}				20	pF
POWER REQUIREMENTS						
Digital Power Supply	D _{VDD}		1.71	1.8	1.89	V
HDMI/MHL Terminator Supply	T _{VDD}		3.14	3.3	3.46	V
HDMI/MHL Comparator Supply	C _{VDD}		1.71	1.8	1.89	V
PLL Power Supply	P _{VDD}		1.71	1.8	1.89	V
MIPI Transmitters Power Supply	M _{VDD}		1.71	1.8	1.89	V
Digital Input/Output Power Supply ¹	D _{VDDIO}	3.3 V operation	3.14	3.3	3.46	V
Analog Power Supply	A _{VDD}		1.71	1.8	1.89	V
CURRENT CONSUMPTION ^{1, 2, 3, 4}						
Digital Supply Current	I _{DVDD}				279	mA
Single-Ended CVBS Input				74.5		mA
Fully Differential and Pseudo Differential CVBS Input				74.7		mA
Y/C Input				71.3		mA
YPbPr Input				72.8		mA
HDMI Input				68.1		mA
MHL Input				93.5		mA
8-Bit Digital Input				32.5		mA

Parameter	Symbol	Test Conditions/Comments	Min	Typ	Max	Unit
HDMI/MHL Terminator Supply Current	I _{TVDD}				40	mA
Single-Ended CVBS Input			0.7			mA
Fully Differential and Pseudo Differential CVBS Input			0.7			mA
Y/C Input			0.7			mA
YPbPr Input			0.7			mA
HDMI Input			35			mA
MHL Input			24.4			mA
8-Bit Digital Input			0.7			mA
HDMI/MHL Comparator Supply Current	I _{CVDD}				92	mA
Single-Ended CVBS Input			0.1			mA
Fully Differential and Pseudo Differential CVBS Input			0.1			mA
Y/C Input			0.1			mA
YPbPr Input			0.1			mA
HDMI Input			63.9			mA
MHL Input			55.9			mA
8-Bit Digital Input			0.1			mA
PLL Supply Current	I _{PVDD}				52	mA
Single-Ended CVBS Input			37.5			mA
Fully Differential and Pseudo Differential CVBS Input			37.5			mA
Y/C Input			37.7			mA
YPbPr Input			37.7			mA
HDMI Input			29.2			mA
MHL Input			29.3			mA
8-Bit Digital Input			27.9			mA
MIPI Transmitters Supply Current	I _{MVDD}				77	mA
Single-Ended CVBS Input			23.3			mA
Fully Differential and Pseudo Differential CVBS Input			23.3			mA
Y/C Input			23.2			mA
YPbPr Input			23.2			mA
HDMI Input			45.7			mA
MHL Input			38.5			mA
8-Bit Digital Input			38.1			mA
Digital Input/Output Supply Current	I _{DVDDIO}				78	mA
Single-Ended CVBS Input			0.2			mA
Fully Differential and Pseudo Differential CVBS Input			0.2			mA
Y/C Input			0.2			mA
YPbPr Input			0.2			mA
HDMI Input			3.6			mA
MHL Input			0.6			mA
8-Bit Digital Input			0.2			mA
Analog Supply Current	I _{AVDD}				93	mA
Single-Ended CVBS Input			51.9			mA
Fully Differential and Pseudo Differential CVBS Input			70			mA
Y/C Input			63			mA
YPbPr Input			78.5			mA
HDMI Input			0.1			mA
MHL Input			0.1			mA
8-Bit Digital Input			0.1			mA

Parameter	Symbol	Test Conditions/Comments	Min	Typ	Max	Unit
POWER-DOWN CURRENTS ^{2, 5}						
Digital Supply	I _{DVDD_PD}			0.2		mA
HDMI/MHL Terminator Supply	I _{TVDD_PD}			0.4		mA
HDMI/MHL Comparator Supply	I _{CVDD_PD}			0.1		mA
PLL Supply	I _{PVDD_PD}			0.1		mA
MIPI Transmitters Supply	I _{MVDD_PD}			0.1		mA
Digital Input/Output Supply	I _{DVDDIO_PD}			0.2		mA
Analog Supply	I _{AVDD_PD}			0.1		mA
Total Power Dissipation in Power-Down Mode				4		mW

¹ The 8-bit digital input/output port is only available when the DVDDIO supply is between 3.14 V and 3.46 V.

² Guaranteed by lab characterization.

³ Typical current consumption values are recorded with nominal voltage supply levels (including DVDDIO = 3.3 V), Philips test pattern, and at room temperature.

⁴ Maximum current consumption values are recorded with maximum rated voltage supply levels (including DVDDIO = 3.46 V), MoireX video pattern for analog inputs, pseudorandom test pattern for digital inputs, and at worst-case temperature.

⁵ Typical power-down current consumption values are recorded with nominal voltage supply levels (including DVDDIO = 3.3 V) at room temperature.

ANALOG VIDEO SPECIFICATIONS

AVDD = 1.71 V to 1.89 V, DVDD = 1.71 V to 1.89 V, PVDD = 1.71 V to 1.89 V, MVDD = 1.71 V to 1.89 V, CVDD = 1.71 V to 1.89 V, DVDDIO = 3.14 V to 3.46 V, and TVDD = 3.14 V to 3.46 V, specified at operating temperature range, unless otherwise noted.

Table 2.

Parameter	Symbol	Test Conditions/Comments	Min	Typ	Max	Unit
NONLINEAR SPECIFICATIONS ^{1, 2}						
Differential Phase	DP	CVBS input, modulated five-step		0.9		Degrees
Differential Gain	DG	CVBS input, modulated five-step		0.5		%
Luma Nonlinearity	LNL	CVBS input, five-step		2.0		%
NOISE SPECIFICATIONS						
Signal-to-Noise Ratio, Unweighted ²	SNR	Luma ramp		57.1		dB
		Luma flat field		58		dB
Analog Front-End Crosstalk ³				60		dB
Common-Mode Rejection Ratio ^{2, 4}	CMRR			73		dB
LOCK TIME SPECIFICATIONS						
Horizontal Lock Range ³			-5		+5	%
Vertical Lock Range ³			40		70	Hz
Subcarrier Lock Range ³	f _{sc}			±1.3		kHz
Color Lock-In Time ³				60		Lines
Synchronization Depth Range ³			20		200	%
Color Burst Range ³			5		200	%
Fast Switch Speed ^{2, 5}				100		ms

¹ These specifications apply to all CVBS input types, as well as to single-ended and differential CVBS inputs.

² Guaranteed by lab characterization.

³ Guaranteed by design.

⁴ The CMRR of this circuit design is critically dependent on the external resistor matching its inputs. This measurement was performed with 0.1% tolerant resistors, a common-mode voltage of 1 V, and a common-mode frequency of 10 kHz.

⁵ The time it takes the [ADV7481](#) to switch from one analog input (single ended or differential) to another, for example, switching from AIN1 to AIN2.

MIPI VIDEO OUTPUT SPECIFICATIONS

AVDD = 1.71 V to 1.89 V, DVDD = 1.71 V to 1.89 V, PVDD = 1.71 V to 1.89 V, MVDD = 1.71 V to 1.89 V, CVDD = 1.71 V to 1.89 V, DVDDIO = 3.14 V to 3.46 V, and TVDD = 3.14 V to 3.46 V, specified at operating temperature range, unless otherwise noted.

The ADV7481 MIPI CSI-2 transmitters conform to the MIPI D-PHY Version 1.00.00 specification by characterization. The clock lane of the ADV7481 remains in high speed (HS) mode even when the data lane enters low power (LP) mode. For this reason, some measurements on the clock lane that pertain to low power mode are not applicable. Unless otherwise stated, all high speed measurements were performed with the ADV7481 operating with a nominal 1 Gbps output data rate.

Table 3.

Parameter	Symbol	Min	Typ	Max	Unit
UNIT INTERVAL ¹	UI	1		12.5	ns
DATA LANE LP Tx DC SPECIFICATIONS ²					
Thevenin Output					
High Level	V _{OH}	1.1	1.2	1.3	V
Low Level	V _{OL}	-50	0	+50	mV
CLOCK LANE LP Tx DC SPECIFICATIONS ²					
Thevenin Output					
High Level	V _{OH}	1.1	1.2	1.3	V
Low Level	V _{OL}	-50	0	+50	mV
DATA LANE HS Tx SIGNALING REQUIREMENTS					
High Speed Differential Voltage Swing	V ₁	140	200	270	mV p-p
Differential Voltage Mismatch				10	mV
Single-Ended Output High Voltages				360	mV
Static Common-Mode Voltage Level				150	200
CLOCK LANE HS Tx SIGNALING REQUIREMENTS					
High Speed Differential Voltage Swing	V ₂	140	200	270	mV p-p
Differential Voltage Mismatch				10	mV
Single-Ended Output High Voltages				360	mV
Static Common-Mode Voltage Level				150	200
HS Tx CLOCK TO DATA LANE TIMING REQUIREMENTS					
Data to Clock Skew		0.35 × UI		0.65 × UI	ns

¹ Guaranteed by design.

² These measurements were performed with C_{LOAD} = 50 pF.

ANALOG SPECIFICATIONS

AVDD = 1.71 V to 1.89 V, DVDD = 1.71 V to 1.89 V, PVDD = 1.71 V to 1.89 V, MVDD = 1.71 V to 1.89 V, CVDD = 1.71 V to 1.89 V, DVDDIO = 3.14 V to 3.46 V, and TVDD = 3.14 V to 3.46 V, specified at operating temperature range, unless otherwise noted.

Table 4.

Parameter	Test Conditions/Comments	Min	Typ	Max	Unit	
CLAMP CIRCUITRY						
External Clamp Capacitor	Required by design		0.1		μF	
Large Clamp						
Source Current			0.32		mA	
Sink Current			0.32		mA	
Fine Clamp						
Source Current			7		μA	
Sink Current		7		μA		

TIMING SPECIFICATIONS

AVDD = 1.71 V to 1.89 V, DVDD = 1.71 V to 1.89 V, PVDD = 1.71 V to 1.89 V, MVDD = 1.71 V to 1.89 V, CVDD = 1.71 V to 1.89 V, DVDDIO = 3.14 V to 3.46 V, and TVDD = 3.14 V to 3.46 V, specified at operating temperature range, unless otherwise noted.

Table 5.

Parameter	Symbol	Test Conditions/Comments	Min	Typ	Max	Unit
CLOCK AND CRYSTAL						
Nominal Frequency ¹				28.63636		MHz
Frequency Stability ¹					±50	ppm
Input LLC Clock Frequency Range ^{2,3}		DVDDIO = 3.14 V to 3.46 V	13.5		148.5	MHz
Output LLC Clock Frequency Range ^{2,3}		DVDDIO = 3.14 V to 3.46 V	13.5		148.5	MHz
SPI_SCLK Frequency ³					10	MHz
I2S_SCLK Frequency ³					12.288	MHz
I2S_MCLK Frequency ³					24.576	MHz
I²C PORT						
SCLK Frequency					400	kHz
SCLK Minimum Pulse Width High	t ₁		0.6			µs
SCLK Minimum Pulse Width Low	t ₂		1.3			µs
Hold Time (Start Condition)	t ₃		0.6			µs
Setup Time (Start Condition)	t ₄		0.6			µs
SDATA Setup Time	t ₅		100			ns
SCLK and SDATA Rise Times	t ₆				300	ns
SCLK and SDATA Fall Times	t ₇				300	ns
Setup Time (Stop Condition)	t ₈			0.6		µs
SPI PORT						
Slave Mode						
$\overline{\text{SPI_CS}}$ Falling Edge to SPI_SCLK Active Edge	t ₉	SPI_SCLK active edge (rising or falling edge) depends on the values of CPHA and CPOL	35			ns
SPI_SCLK Active Edge to $\overline{\text{SPI_CS}}$ Rising Edge	t ₁₀	SPI_SCLK active edge (rising or falling edge) depends on the values of CPHA and CPOL	35			ns
$\overline{\text{SPI_CS}}$ Pulse Width	t ₁₁		50			ns
SPI_SCLK High Time ³	t ₁₂		45		55	% duty cycle
SPI_SCLK Low Time ³	t ₁₂		45		55	% duty cycle
SPI_MOSI Setup Time	t ₁₃	SPI Mode 0, SPI Mode 3	0			ns
SPI_MOSI Hold Time	t ₁₄	SPI Mode 0, SPI Mode 3	35			ns
SPI_SCLK Falling Edge to SPI_MISO Start of Data Invalid ³	t ₁₅	SPI Mode 0, SPI Mode 3			50	ns
SPI_SCLK Falling Edge to SPI_MISO End of Data Invalid ³	t ₁₆	SPI Mode 0, SPI Mode 3			50	ns
SPI_MOSI Setup Time	t ₁₇	SPI Mode 1, SPI Mode 2	0			ns
SPI_MOSI Hold Time	t ₁₈	SPI Mode 1, SPI Mode 2	35			ns
SPI_SCLK Rising Edge to SPI_MISO Start of Data Invalid	t ₁₉	SPI Mode 1, SPI Mode 2			35	ns
SPI_SCLK Rising Edge to SPI_MISO End of Data Invalid	t ₂₀	SPI Mode 1, SPI Mode 2			35	ns
RESET FEATURE						
$\overline{\text{RESET}}$ Pulse Width ¹			5			ms

Parameter	Symbol	Test Conditions/Comments	Min	Typ	Max	Unit
8-BIT DIGITAL INPUT PORT ²		DVDDIO = 3.14 V to 3.46 V				
LLC High Time ³	t ₂₁		45		55	% duty cycle
LLC Low Time ³			45		55	% duty cycle
SDR and DDR Modes Setup Time	t ₂₂	Data latched on rising edge	1			ns
SDR and DDR Modes Hold Time	t ₂₃	Data latched on rising edge	1			ns
DDR Mode Setup Time	t ₂₄	Data latched on falling edge	1			ns
DDR Mode Hold Time	t ₂₅	Data latched on falling edge	1			ns
8-BIT DIGITAL OUTPUT PORT ²		DVDDIO = 3.14 V to 3.46 V				
LLC High Time	t ₂₆		40		60	% duty cycle
LLC Low Time			40		60	% duty cycle
SDR Modes Setup Time ^{4,5}	t ₃₆	At P0 to P7 output pin, data latched on rising edge	1.98			ns
SDR Modes Hold Time ^{4,5}	t ₃₇	At P0 to P7 output pin, data latched on rising edge	2.50			ns
DDR Modes Setup Time ^{4,5}	t ₂₇	At P0 to P7 output pin, data latched on rising edge	1.66			ns
DDR Modes Hold Time ^{4,5}	t ₂₈	At P0 to P7 output pin, data latched on rising edge	3.52			ns
DDR Mode Setup Time ^{4,5}	t ₂₉	At P0 to P7 output pin, data latched on falling edge	1.71			ns
DDR Modes Hold Time ^{4,5}	t ₃₀	At P0 to P7 output pin, data latched on falling edge	3.17			ns
I ² S PORT, MASTER MODE						
I2S_SCLK High Time	t ₃₁		45		55	% duty cycle
I2S_SCLK Low Time			45		55	% duty cycle
I2S_LRCLK Data Transition Time	t ₃₂	End of valid data to I2S_SCLK falling edge			10	ns
	t ₃₃	I2S_SCLK falling edge to start of valid data			10	ns
I2S_SDATA Data Transition Time	t ₃₄	End of valid data to I2S_SCLK falling edge			5	ns
	t ₃₅	I2S_SCLK falling edge to start of valid data			5	ns

¹ Required by design.

² The 8-bit digital input/output port is only available when the DVDDIO supply is between 3.14 V and 3.46 V.

³ Guaranteed by design.

⁴ These specifications only apply when the LLC_DLL_PHASE[4:0] (IO Map, Register 0x0C[4:0]) is set to 00000.

⁵ Guaranteed by lab characterization.

Timing Diagrams

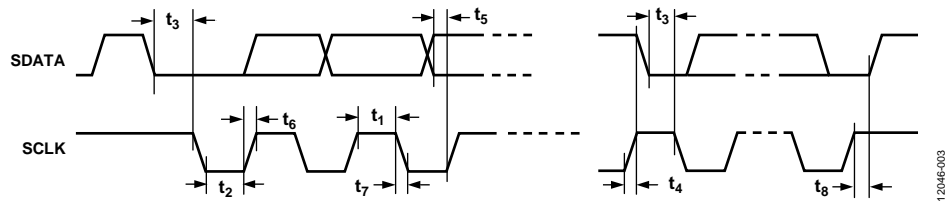

Figure 3. I²C Timing

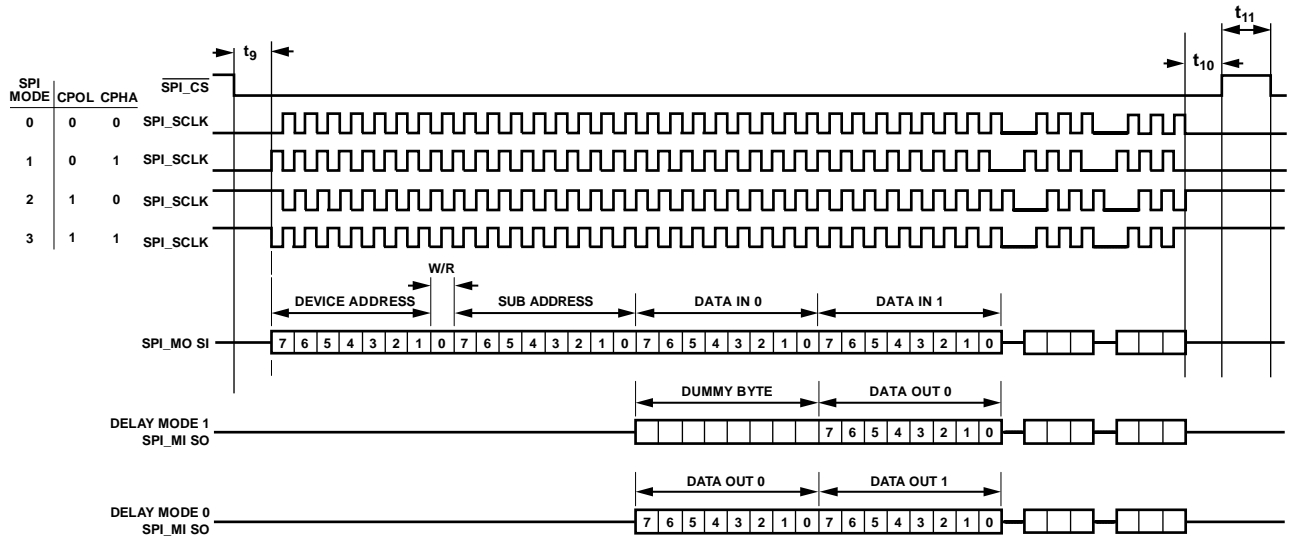

Figure 4. Detailed SPI Slave Timing Diagram

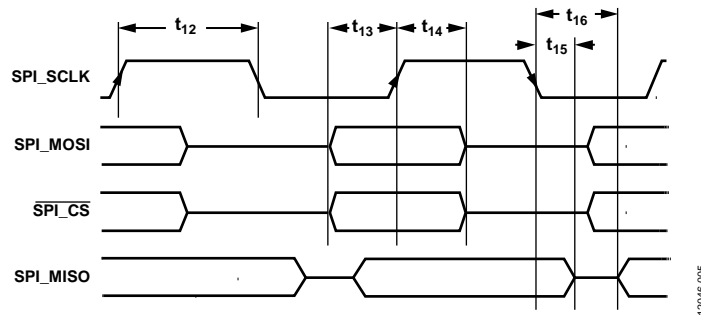

Figure 5. SPI Slave Mode Timing (SPI Mode 0 and SPI Mode 3)

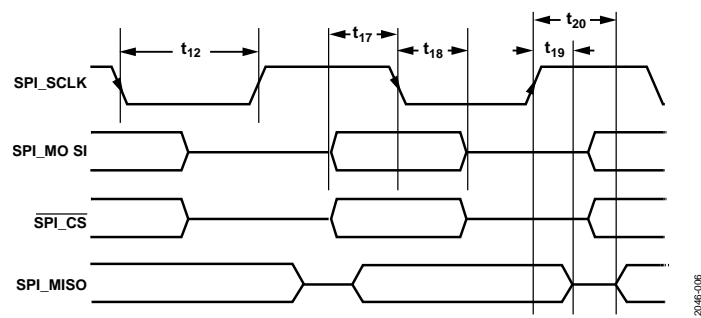

Figure 6. SPI Slave Mode Timing (SPI Mode 1 and SPI Mode 2)

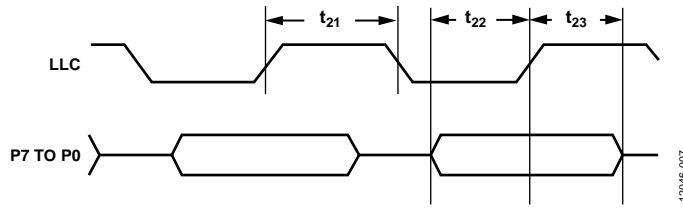

Figure 7. 8-Bit Digital Pixel Video Input, SDR Video Data Timing

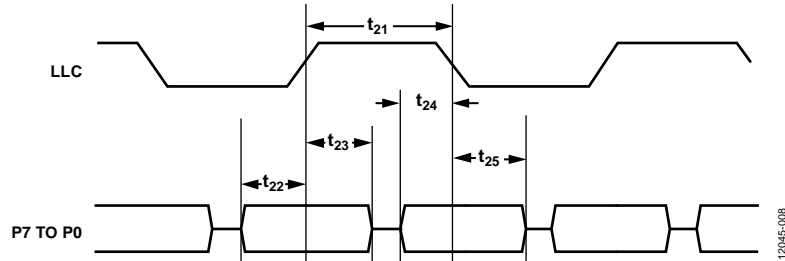

Figure 8. 8-Bit Digital Pixel Video Input, DDR Video Data Timing

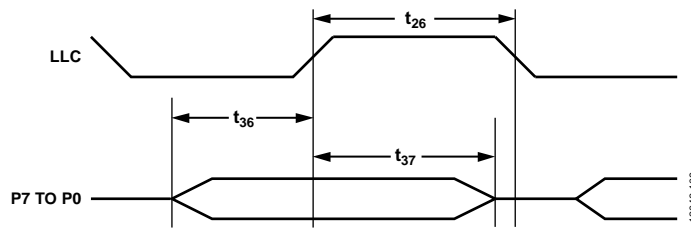

Figure 9. 8-Bit Digital Pixel Video Output, SDR Video Data Timing

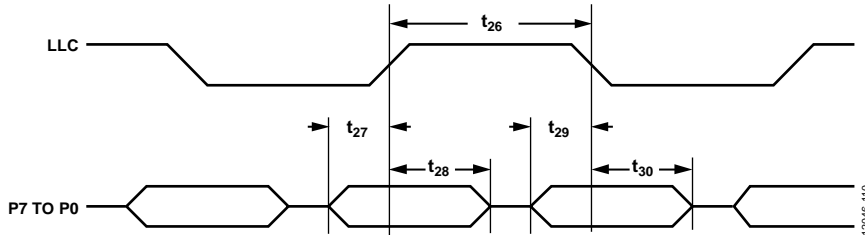

Figure 10. 8-Bit Digital Pixel Video Output, DDR Video Data Timing

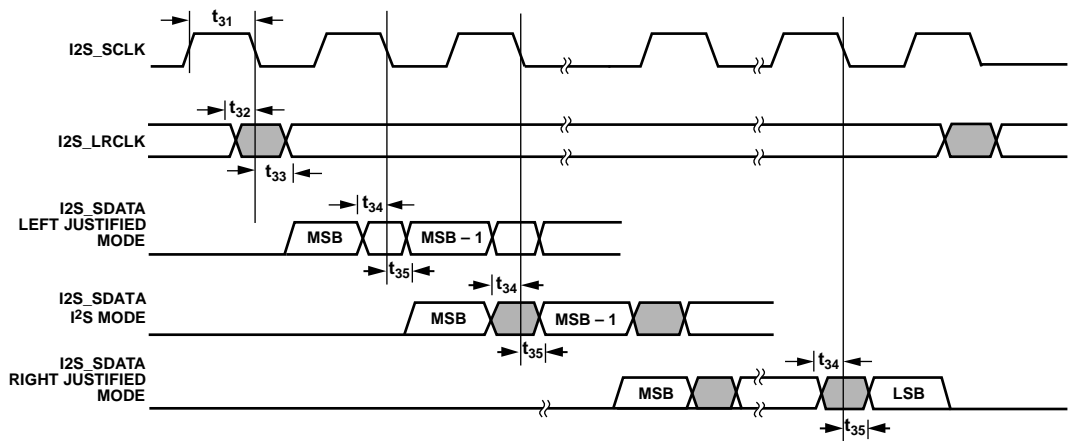

Figure 11. I2S Timing

ABSOLUTE MAXIMUM RATINGS

Table 6.

Parameter	Rating
TVDD, DVDDIO to GND	4 V
AVDD, PVDD, MVDD, DVDD, CVDD to GND	2.2 V
CVDD to DVDD	-0.3 V to +0.3 V
MVDD to DVDD	-0.3 V to +0.3 V
PVDD to DVDD	-0.3 V to +0.3 V
AVDD to DVDD	-0.3 V to +0.3 V
Digital Inputs Voltage to GND	GND - 0.3 V to DVDDIO + 0.3 V
Digital Outputs Voltage to GND	GND - 0.3 V to DVDDIO + 0.3 V
Analog Inputs to GND	-0.3 V to AVDD + 0.3 V
XTALN and XTALP to GND	-0.3 V to PVDD + 0.3 V
HDMI/MHL Digital Inputs Voltage to GND	-0.3 V to CVDD + 0.3 V
5 V Tolerant Inputs Voltage to GND ^{1,2}	-0.3 V to +5.5 V
Maximum Junction Temperature (T _J max)	125°C
Storage Temperature Range	-65°C to +150°C
Infrared Reflow Soldering (20 sec)	260°C

¹ The following inputs are 3.3 V inputs but are 5 V tolerant: DDC_SCL/CD_PULLUP, DDC_SDA, HPD/CBUS, RX_5V/VBUS, CD_SENSE and CEC.

² The following inputs are 1.8 V inputs but are 5 V tolerant: DIAG1, DIAG2, DIAG3, and DIAG4.

Stresses at or above those listed under Absolute Maximum Ratings may cause permanent damage to the product. This is a stress rating only; functional operation of the product at these or any other conditions above those indicated in the operational section of this specification is not implied. Operation beyond the maximum operating conditions for extended periods may affect product reliability.

THERMAL RESISTANCE

To reduce power consumption when using the [ADV7481](#), turn off unused sections of the device.

Due to printed circuit board (PCB) metal variation, and, therefore, variation in PCB heat conductivity, the value of θ_{JA} may differ for various PCBs.

The most efficient measurement solution is achieved using the package surface temperature to estimate the die temperature. This eliminates the variance associated with the θ_{JA} value.

Do not exceed the maximum junction temperature (T_J max) of 125°C. The following equation calculates the junction temperature (T_J) using the measured package surface temperature and applies only when no heat sink is used on the device under test (DUT):

$$T_J = T_S + (\Psi_{JT} \times W_{TOTAL})$$

where:

T_S is the package surface temperature (°C).

$\Psi_{JT} = 0.81^\circ\text{C}/\text{W}$ for the 100-ball CSP_BGA (based on 2s2p test board defined by JEDEC standards).

$$W_{TOTAL} = (PVDD \times I_{PVDD}) + (TVDD \times I_{TVDD}) - P_{UpStream} + (CVDD \times I_{CVDD}) + (AVDD \times I_{AVDD}) + (DVDD \times I_{DVDD}) + (DVDDIO \times I_{DVDDIO}) + (MVDD \times I_{MVDD})$$

where $P_{UpStream}$ is the quantity of TVDD power consumed on the upstream HDMI or MHL transmitter. $P_{UpStream}$ can be estimated to be around 110 mW for a nominal HDMI transmitter. $P_{UpStream}$ can be estimated to be around 42.82 mW for a nominal MHL transmitter.

ESD CAUTION



ESD (electrostatic discharge) sensitive device. Charged devices and circuit boards can discharge without detection. Although this product features patented or proprietary protection circuitry, damage may occur on devices subjected to high energy ESD. Therefore, proper ESD precautions should be taken to avoid performance degradation or loss of functionality.

PIN CONFIGURATION AND FUNCTION DESCRIPTIONS

	1	2	3	4	5	6	7	8	9	10	
A	GND	I2S_SDATA	GND	RX2P	RX1P	RX0P	RXCP	DDC_SCL/CD_PULLUP	VBUS_EN	GND	A
B	MVDD	I2S_SCLK	CVDD	RX2N	RX1N	RX0N	RXCN	DDC_SDA	HPD/CBUS	GND	B
C	CLKAN	CLKAP	I2S_LRCLK	I2S_MCLK	CD_SENSE	TVDD	CEC	RX_5V/VBUS	AIN7	AIN8	C
D	DA0N	DA0P	INTRQ3	DVDD	GND	GND	GND	DIAG4	AIN5	AIN6	D
E	DA1N	DA1P	INTRQ2	GND	GND	GND	AVDD	DIAG3	AIN3	AIN4	E
F	DA2N	DA2P	INTRQ1	GND	GND	GND	GND	VREFN	AIN1	AIN2	F
G	DA3N	DA3P	TEST	DVDD	GND	GND	GND	VREFP	DIAG1	DIAG2	G
H	DB0N	DB0P	DVDDIO	P1	P4	SPI_MOSI	SPI_CS	RESET	PVDD	GND	H
J	CLKBN	CLKBP	MVDD	P2	P5	P7	SPI_MISO	SCLK	XTALN	XTALP	J
K	GND	MVDD	P0	P3	P6	LLC	SPI_SCLK	SDATA	ALSB	GND	K
	1	2	3	4	5	6	7	8	9	10	

Figure 12. Pin Configuration

Table 7. Pin Function Descriptions

Pin No.	Mnemonic	Type	Description
A1	GND	Ground	Ground.
A2	I2S_SDATA	Output	I2S Audio Output.
A3	GND	Ground	Ground.
A4	RX2P	HDMI	HDMI Digital Input Channel 2.
A5	RX1P	HDMI	HDMI Digital Input Channel 1.
A6	RX0P	HDMI/MHL	HDMI Digital Input Channel 0 or MHL Positive Input.
A7	RXCP	HDMI	HDMI Input Clock.
A8	DDC_SCL/CD_PULLUP	HDMI/MHL	HDCP Slave Serial Clock or MHL Cable Detect Pull-Up.
A9	VBUS_EN	MHL	Enable Control Signal for Voltage Regulator Providing a 5 V VBUS Supply.
A10	GND	Ground	Ground.
B1	MVDD	Power	MIPI Supply Voltage (1.8 V).
B2	I2S_SCLK	Output	Audio Serial Clock.
B3	CVDD	Power	HDMI/MHL Comparator Supply Voltage (1.8 V). This is the supply for the HDMI/MHL sensitive analog circuitry. Blocks on this supply include the TMDS PLL and the equalizers.
B4	RX2N	HDMI	HDMI Digital Input Channel 2 Complement.
B5	RX1N	HDMI	HDMI Digital Input Channel 1 Complement.
B6	RX0N	HDMI/MHL	HDMI Digital Input Channel 0 Complement or MHL Negative Input.
B7	RXCN	HDMI	HDMI Input Clock Complement.
B8	DDC_SDA	HDMI	HDCP Slave Serial Data.
B9	HPD/CBUS	HDMI/MHL	HDMI Hot Plug Assert or MHL CBUS.
B10	GND	Ground	Ground.

Pin No.	Mnemonic	Type	Description
C1	CLKAN	Output	MIPI Transmitter A Negative Output Clock.
C2	CLKAP	Output	MIPI Transmitter A Positive Output Clock.
C3	I2S_LRCLK	Output	Audio Left/Right Clock.
C4	I2S_MCLK	Output	Audio Master Clock Output.
C5	CD_SENSE	MHL	MHL Cable Detection Sense Input.
C6	TVDD	Power	HDMI/MHL Terminator Supply Voltage (3.3 V).
C7	CEC	HDMI	CEC Channel.
C8	RX_5V/VBUS	HDMI/MHL	HDMI 5 V Detect or MHL VBUS. A large pull-down resistor (100 k Ω , typical) to ground must be connected to this pin.
C9	AIN7	Input	Analog Video Input Channel.
C10	AIN8	Input	Analog Video Input Channel.
D1	DA0N	Output	MIPI Transmitter A Negative Data Output.
D2	DA0P	Output	MIPI Transmitter A Positive Data Output.
D3	INTRQ3	Output	Interrupt Request Output.
D4	DVDD	Power	Digital Supply Voltage (1.8 V).
D5	GND	Ground	Ground.
D6	GND	Ground	Ground.
D7	GND	Ground	Ground.
D8	DIAG4	Input	Analog Video Diagnostic Input. This input is 5 V tolerant.
D9	AIN5	Input	Analog Video Input Channel.
D10	AIN6	Input	Analog Video Input Channel.
E1	DA1N	Output	MIPI Transmitter A Negative Data Output.
E2	DA1P	Output	MIPI Transmitter A Positive Data Output.
E3	INTRQ2	Output	Interrupt Request Output.
E4	GND	Ground	Ground.
E5	GND	Ground	Ground.
E6	GND	Ground	Ground.
E7	AVDD	Power	Analog Supply Voltage (1.8 V).
E8	DIAG3	Input	Analog Video Diagnostic Input. This input is 5 V tolerant.
E9	AIN3	Input	Analog Video Input Channel.
E10	AIN4	Input	Analog Video Input Channel.
F1	DA2N	Output	MIPI Transmitter A Negative Data Output.
F2	DA2P	Output	MIPI Transmitter A Positive Data Output.
F3	INTRQ1	Output	Interrupt Request Output.
F4	GND	Ground	Ground.
F5	GND	Ground	Ground.
F6	GND	Ground	Ground.
F7	GND	Ground	Ground.
F8	VREFN	Output	Internal Voltage Reference Output.
F9	AIN1	Input	Analog Video Input Channel.
F10	AIN2	Input	Analog Video Input Channel.
G1	DA3N	Output	MIPI Transmitter A Negative Data Output.
G2	DA3P	Output	MIPI Transmitter A Positive Data Output.
G3	TEST	Miscellaneous	Do Not Connect. This pin must be left unconnected.
G4	DVDD	Power	Digital Supply Voltage (1.8 V).
G5	GND	Ground	Ground.
G6	GND	Ground	Ground.
G7	GND	Ground	Ground.
G8	VREFP	Output	Internal Voltage Reference Output.
G9	DIAG1	Input	Analog Video Diagnostic Input. This input is 5 V tolerant.
G10	DIAG2	Input	Analog Video Diagnostic Input. This input is 5 V tolerant.

Pin No.	Mnemonic	Type	Description
H1	DB0N	Output	MIPI Transmitter B Negative Data Output.
H2	DB0P	Output	MIPI Transmitter B Positive Data Output.
H3	DVDDIO	Power	Digital Input/Output Supply Voltage (3.3 V).
H4	P1	Input/Output	Video Pixel Input/Output Port.
H5	P4	Input/Output	Video Pixel Input/Output Port.
H6	SPI_MOSI	Input	SPI Slave Data Input.
H7	SPI_CS	Input	SPI Slave Chip Select Input.
H8	RESET	Input	System Reset Input, Active Low. A minimum low reset pulse of 5 ms is required to reset the chip.
H9	PVDD	Power	PLL Supply Voltage (1.8 V).
H10	GND	Ground	Ground.
J1	CLKBN	Output	MIPI Transmitter B Negative Output Clock.
J2	CLKBP	Output	MIPI Transmitter B Positive Output Clock.
J3	MVDD	Power	MIPI Supply Voltage (1.8 V).
J4	P2	Input/Output	Video Pixel Input/Output Port.
J5	P5	Input/Output	Video Pixel Input/Output Port.
J6	P7	Input/Output	Video Pixel Input/Output Port.
J7	SPI_MISO	Output	SPI Slave Data Output.
J8	SCLK	Input	I ² C Port Serial Clock Input.
J9	XTALN	Output	Crystal Output. This pin must be connected to the 28.63636 MHz crystal or not connected if an external 1.8 V, 28.63636 MHz clock oscillator is used. In crystal mode, the crystal must be a fundamental crystal.
J10	XTALP	Input	Crystal Input or External Clock Input. This pin must be connected to the 28.63636 MHz crystal or connected to an external 1.8 V, 28.63636 MHz clock oscillator if a clock oscillator is used. In crystal mode, the crystal must be a fundamental crystal.
K1	GND	Ground	Ground.
K2	MVDD	Power	MIPI Supply Voltage (1.8 V).
K3	P0	Input/Output	Video Pixel Input/Output Port.
K4	P3	Input/Output	Video Pixel Input/Output Port.
K5	P6	Input/Output	Video Pixel Input/Output Port.
K6	LLC	Input/Output	Line Locked Clock. Input/output clock for the pixel data.
K7	SPI_SCLK	Input	SPI Slave Clock Input.
K8	SDATA	Input/Output	I ² C Port Serial Data Input/Output.
K9	ALSB	Input	Main I ² C Address Selection Pin. This pin selects the main I ² C address (IO Map I ² C address) for the device. When ALSB is set to Logic 0, the IO Map I ² C write address is 0xE0; when ALSB is set to Logic 1, the IO Map I ² C write address is 0xE2.
K10	GND	Ground	Ground.

POWER SUPPLY RECOMMENDATION

POWER-UP SEQUENCE

Adhere to the absolute maximum ratings at all times during power-up (see Table 6). The power-up sequence for the ADV7481 is as follows:

1. Assert $\overline{\text{RESET}}$ (pull the pin low).
2. Power up the 3.3 V supplies (D_{VDDIO} and T_{VDD}). These supplies must be powered up simultaneously.
3. Power up the 1.8 V supplies (D_{VDD} , C_{VDD} , P_{VDD} , M_{VDD} , and A_{VDD}). These supplies must be powered up simultaneously.
4. $\overline{\text{RESET}}$ can be deasserted (pulled high) 5 ms after all supplies are fully powered up.
5. After all power supplies and the $\overline{\text{RESET}}$ pin are powered up and stable, wait an additional 5 ms before initiating I²C communication with the ADV7481.

POWER-DOWN SEQUENCE

The ADV7481 power supplies can be deasserted simultaneously as long as a higher rated supply (for example, D_{VDDIO}) does not fall to a voltage level less than a lower rated supply (for example, D_{VDD}), and the absolute maximum ratings specifications are followed.

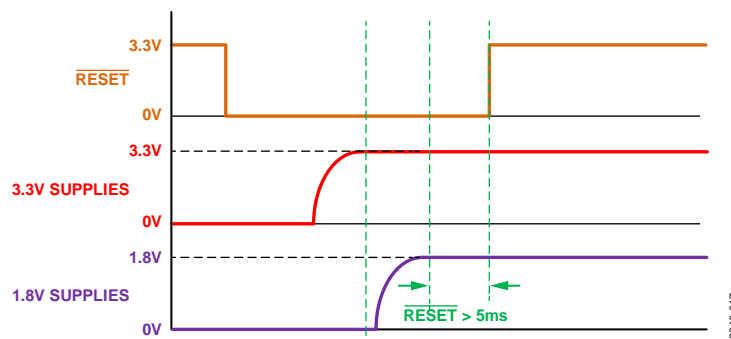

Figure 13. Supply Power-Up Sequence

THEORY OF OPERATION

COMBINED HDMI/MHL RECEIVER

The [ADV7481](#) features a combined HDMI/MHL receiver. This single receiver port is capable of accepting both HDMI and MHL electrical signals. Automatic detection between HDMI and MHL is achieved by using cable impedance detection through the CD_SENSE pin.

Both MHL and HDMI interfaces of the [ADV7481](#) allow authentication of a video receiver, decryption of encoded data at the receiver, and renewability of that authentication during transmission, as specified by the HDCP 1.4 protocol.

Dual extended display identification data (EDID) support is provided via an on-chip 512-byte EDID RAM. The EDID RAM must be programmed at power-up. It can be configured as two 256-byte EDIDs for dual mode operation (one 256-byte EDID for the HDMI receiver, and one 256-byte EDID for the MHL receiver), or as a single 512-byte EDID for single mode operation.

The [ADV7481](#) has a synchronization regeneration block used to regenerate the data enable (DE) signal based on the measurement of the video format being displayed and to filter the horizontal and vertical synchronization signals to prevent glitches.

The combined HDMI/MHL receiver also supports TMDS error reduction coding, 4-bit (TERC4) error detection, used for the detection of corrupted HDMI or MHL packets.

MHL RECEIVER

The MHL receiver supports video formats ranging from 480i to 720p/1080i, and display resolutions from VGA (640 × 480 at 60 Hz) to XGA (1024 × 768 at 60 Hz).

The MHL receiver allows programmable equalization of the MHL data signals. This equalization compensates for the high frequency losses inherent in MHL cabling, especially at longer lengths and higher frequencies. The receiver is capable of equalizing for cable lengths of up to 2 meters to achieve robust receiver performance.

The MHL receiver includes the following pins:

- RX0N and RX0P. In MHL mode, this differential pair receives the data transmitted as a differential signal and the clock transmitted on the common mode.
- HPD/CBUS. In MHL mode, this pin is used for CBUS communication.
- VBUS_EN. This pin provides an enable signal for an external source providing 5 V of power to the MHL source on VBUS.
- RX_5V/VBUS. In MHL mode, this pin is an input monitoring the VBUS signal provided by an external source enabled by VBUS_EN.
- CD_SENSE. This pin detects whether the signals provided to the HDMI/MHL receiver are HDMI signals or MHL signals. A high level indicates MHL, and a low level indicates HDMI.

The implementation of the MSC commands by the system processor can be handled either through the I²C bus, or via a dedicated SPI bus. A dedicated interrupt pin (INTRQ3) is available to indicate that events related to the CBUS have occurred.

The main MHL receiver features include

- Support for a pixel clock up to 75 MHz in 24-bit mode, allowing support for video formats up to 720p/1080i and display resolutions up to XGA in either RGB, YCbCr 4:4:4, or YCbCr 4:2:2 formats.
- Integrated fully adaptive equalizer for cable lengths up to 2 meters.
- HDCP 1.4 support
- Internal HDCP keys.
- HDCP repeater support, up to 25 key selection vectors (KSVs) supported.
- Pulse code modulation (PCM) audio packet support.
- Support for 8-channel TDM output data up to 48 kHz.
- Repeater support.
- Internal EDID RAM (512-byte for single mode, and 256-byte for dual mode operation).
- Scratchpad register support with a size of 64 bytes.

HDMI RECEIVER

The HDMI receiver supports video formats ranging from 480i to 1080p, and display resolutions from VGA (640 × 480 at 60 Hz) to UXGA (1600 × 1200 at 60 Hz).

The HDMI receiver allows programmable equalization of the HDMI data signals. This equalization compensates for the high frequency losses inherent in HDMI and DVI cabling, especially at longer lengths and higher frequencies. The receiver is capable of equalizing for cable lengths up to 30 meters to achieve robust receiver performance.

The main HDMI receiver features include

- 162.0 MHz (UXGA at 24 BPP) maximum TMDS clock frequency.
- Integrated fully adaptive equalizer for cable lengths up to 30 meters.
- HDCP 1.4 support.
- Internal HDCP keys.
- HDCP repeater support, up to 25 key selection vectors (KSVs) supported.
- PCM audio packet support.
- Support for 8-channel TDM output data up to 48 kHz.
- Repeater support.
- Internal EDID RAM (512-byte for single mode, and 256-byte for dual mode operation).
- Hot Plug assert output pin (HPD/CBUS).
- CEC controller.

COMPONENT PROCESSOR

The **ADV7481** has one any-to-any 3×3 CSC matrix. The CSC block is located in the processing path before the CP section. CSC enables YCbCr-to-RGB and RGB-to-YCbCr conversions. Many other standards of color space can be implemented using the color space converter.

CP features include

- Support for all video modes supported by the HDMI/MHL receiver. These include 525i, 625i, 525p, 625p, 1080i, 1080p, and display resolutions from VGA (640×480 at 60 Hz) to UXGA (1600×1200 at 60 Hz).
- Manual adjustments including gain (contrast), offset (brightness), hue, and saturation.
- Free run output mode that provides stable timing when no video input is present.
- Timing adjustments controls for HS/VS/DE timing.

ANALOG FRONT END

The **ADV7481** AFE comprises a single high speed, 10-bit ADC that digitizes the analog video signal before applying it to the SDP. The AFE uses differential channels to the ADC to ensure high performance in mixed-signal applications and to enable differential CVBS to be connected directly to the **ADV7481**.

Up to eight analog inputs can be connected to the AFE. The front end also includes an 8-channel input mux that enables different configurations of single-ended CVBS (up to eight), pseudo differential or fully differential CVBS (up to four), Y/C (up to four), and YPbPr (up to two) analog inputs.

Current clamps are positioned in front of the ADC to ensure that the video signal remains within the range of the converter. A resistor divider network is required before each analog input channel to ensure that the input signal is within the range of the ADC. Figure 14 shows a typical voltage divider network for single-ended inputs, Figure 15 shows a typical voltage divider network for pseudo differential inputs, and Figure 16 shows a typical voltage divider network for fully differential inputs. The choice of the resistor divider shown in Figure 16 provides a common-mode range of up to 4 V in fully differential CVBS input mode. Fine clamping of the video signal is performed downstream by digital fine clamping within the **ADV7481**.

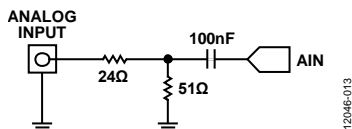

Figure 14. Typical Single-Ended Input Voltage Divider Network

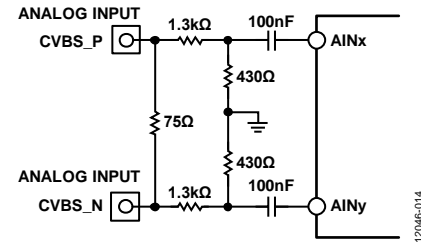

Figure 15. Typical Pseudo Differential Input Resistor Divider Network

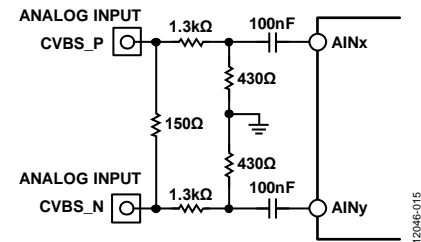

Figure 16. Typical Fully Differential Input Resistor Divider Network

The ADC features three clocking rates that allow $4\times$ oversampling per channel for CVBS mode, Y/C mode, and YPbPr mode.

The fully differential AFE of the **ADV7481** provides inherent small and large signal noise rejection, improved electromagnetic interference (EMI) protection, and the ability to absorb ground bounce. Support is provided for both true differential and pseudo differential signals.

The main AFE features include

- A single 172 MHz, 10-bit ADC that enables true 8-bit video decoding.
- 8-channel analog input mux that enables multiple source connections without the requirement of an external mux.
- A current clamp control loop that ensures that any dc offsets are removed from the video signal entering the SDP.
- Diagnostic capability on all differential inputs.
- Support for 4 V common-mode input range.
- Support for analog input signals up to 1 V p-p.
- Support for single-ended, pseudo differential, and fully differential inputs.

SHORT TO BATTERY DIAGNOSTICS

In differential mode, the **ADV7481** is protected against STB events by ac coupling capacitors (see Figure 15 and Figure 16). The input network resistors are sized to reduce the current flow during an STB event, thus preventing damage to the resistors. Note that the input network resistors and the ac coupling capacitors must be chosen with ratings guaranteeing they are able to withstand the high voltage of STB events.

The four diagnostic inputs of the **ADV7481** provide diagnostic capability for all differential inputs. The **ADV7481** can detect an STB event on either the positive or the negative composite input and trigger an interrupt. The $75\ \Omega$ (pseudo differential) or $150\ \Omega$ (fully differential) parallel termination resistor enables one

DIAGx pin to sense an STB event on either input, because there is a minimal voltage drop across the resistor.

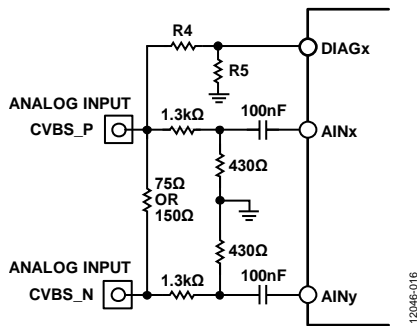

Figure 17. Diagnostic Connection for Differential Inputs

Resistors R4 and R5 divide down the voltage at the input connector to protect the DIAGx pin from an STB event. The DIAGx pin circuitry compares this voltage to a programmable reference voltage, known as the diagnostic slice level. When the diagnostic slice level is exceeded, an STB event has occurred.

R4 and R5 are sized to allow the use of low cost, small footprint resistors that are tolerant of STB events.

Use the following equation to find the STB voltage for a selected diagnostic slice level.

$$V_{STB_TRIGGER} = \frac{R5 + R4}{R5} \times DIAGNOSTIC_SLICE_LEVEL$$

where:

$V_{STB_TRIGGER}$ is the minimum voltage required at the input connector to trigger the STB interrupt on the ADV7481.
 $DIAGNOSTIC_SLICE_LEVEL$ is the programmable reference voltage.

For example, with a diagnostic slice level programmed to 1.125 V, an R4 value of 9.1 kΩ, and an R5 value of 1 kΩ, the minimum voltage required at the input connector to trigger the STB interrupt is approximately 11.4 V.

When the DIAGx pin voltage exceeds the diagnostic slice level voltage, a hardware interrupt is triggered and indicated by one of the interrupt pins. A readback register specifies the input on which the STB event occurred.

STANDARD DEFINITION PROCESSOR

The ADV7481 is capable of decoding a large selection of baseband video signals in composite (both single-ended and differential), S-Video, and component formats. The video standards supported by the video processor include

- PAL B, PAL D, PAL G, PAL H, PAL I, PAL M, PAL N, PAL Nc, and PAL 60
- NTSC J, NTSC M, and NTSC 4.43
- SECAM B, SECAM D, SECAM G, SECAM K, and SECAM L

The ADV7481 can automatically detect the video standard and process it accordingly.

The ADV7481 has a five-line adaptive 2D comb filter that provides superior chrominance and luminance separation when

decoding a composite video signal. This highly adaptive filter automatically adjusts its processing mode according to the video standard and signal quality without requiring user intervention. Video user controls such as brightness, contrast, saturation, and hue are also available with the ADV7481.

The ADV7481 implements the patented Adaptive Digital Line Length Tracking (ADLLT™) algorithm to track varying video line lengths from sources such as a VCR. ADLLT enables the ADV7481 to track and decode poor quality video sources such as VCRs and noisy sources from tuner outputs, VCD players, and camcorders. The ADV7481 contains a chroma transient improvement (CTI) processor that sharpens the edge rate of chroma transitions, resulting in sharper vertical transitions.

The ACE of the ADV7481 offers improved visual detail using an algorithm that automatically varies contrast levels to enhance picture detail. ACE allows the contrast of an image to increase depending on the content of the picture. Typically, this allows bright areas to be made brighter and dark areas to be made darker. However, the ADV7481 ACE feature also allows the contrast within dark areas to increase without significantly affecting the bright areas of the picture. This feature is particularly useful in automotive applications, where it is important to discern objects in shaded areas.

Downdithering converts the output of the ADV7481 from an 8-bit to a 6-bit output, enabling ease of design for standard LCD panels.

The SDP can process a variety of VBI data services, such as closed captioning (CCAP), wide screen signaling (WSS), and copy generation management system (CGMS).

The ADV7481 is fully Rovi® (Macrovision®) compliant; detection circuitry enables Type I, Type II, and Type III protection levels to be identified and reported to the user. The decoder is also fully robust to all Macrovision signal inputs.

8-BIT DIGITAL INPUT/OUTPUT PORT

The ADV7481 features an 8-bit digital bidirectional port. The following formats are supported both as input and output ports:

- 8-bit interleaved 4:2:2 SDR input/output with embedded timing codes
- 8-bit interleaved 4:2:2 DDR input/output with embedded timing codes

The maximum input and output video resolution supported is 720p/1080i in both SDR and DDR modes.

Video received on the 8-bit digital input port can be routed to the four-lane MIPI CSI-2 transmitter. Video sent on the 8-bit digital output port can be routed from either the SD core or the CP core.

AUDIO PROCESSING

The [ADV7481](#) features an audio processor that handles the audio extracted from the MHL or HDMI stream by the HDMI/MHL receiver. It contains an audio mute controller that can detect a variety of conditions that may result in audible extraneous noise in the audio output. On detection of these conditions, a 2-channel linear PCM audio signal can be ramped down to a mute state to prevent audio clicks or pops.

The audio is output on a single flexible serial digital audio output port supporting I²S-compatible, left justified, and right justified audio output modes in master mode only. TDM is also supported, allowing up to eight audio channels with a sample rate up to 48 kHz to be transmitted over the single serial digital audio interface.

MIPI CSI-2 TRANSMITTERS

The [ADV7481](#) features two MIPI CSI-2 transmitters: a four-lane transmitter (Transmitter A) and a single lane transmitter (Transmitter B).

The four-lane transmitter consists of four differential data lanes (DA0N, DA0P, DA1N, DA1P, DA2N, DA2P, DA3N, and DA3P), and a differential clock lane (CLKAN and CLKAP). It supports four data lanes, two data lanes, and one data lane muxing options, and can be used to transmit video received on either the HDMI/MHL receiver (processed through the CP), the 8-bit digital input port, or the AFE (processed through the SDP).

The main features of the four-lane MIPI transmitter (Transmitter A) include

- Support for 8-bit and 10-bit YCbCr 4:2:2 video modes.
- Support for 24-bit RGB 4:4:4 (RGB888), 18-bit RGB 4:4:4 (RGB666), and 16-bit RGB 4:4:4 (RGB565) video modes.
- Support for video formats ranging from 480i to 1080p, and display resolutions from VGA to UXGA (certain restrictions apply to the muxing option, video mode, and video format that can be selected).
- Data lanes and clock lane remapping to ease PCB layout.

The single lane transmitter consists of a single differential data lane (DB0N and DB0P) and a differential clock lane (CLKBN and CLKBP). It transmits video received on the AFE (processed through the SDP).

The main features of the single lane MIPI transmitter (Transmitter B) include

- Support for 8-bit YCbCr 4:2:2 video mode.
- Support for 480i and 576i video formats.

INTERRUPTS

The [ADV7481](#) features three interrupt request pins. INTRQ1 and INTRQ2 can be programmed to trigger interrupts based on various selectable events related to the HDMI/MHL receiver (video and audio related), the SDP, and the CP. INTRQ3 is dedicated to events related to the MHL CBUS.

Looking for pricing, stock, or lifecycle information?

Click below to explore more details on WIN SOURCE:

 [View ADV7481WBBCZ on WIN SOURCE](#)

 [Analog Devices Inc. Information](#)

Optimize Your Supply Chain with WIN SOURCE Solutions

-  Global Sourcing Solution
-  Obsolete Management
-  Cost Control Management
-  Shortage Management
-  Alternative Solution
-  Excess Inventory Management