

FEATURES

- Operation from 700 MHz to 2700 MHz
- Gain of 12.2 dB at 2630 MHz
- OIP3 of 42.2 dBm at 2630 MHz
- P1dB of 29.1 dBm at 2630 MHz
- Noise figure of 4.6 dB at 2630 MHz
- Single 5 V power supply
- Low quiescent current of 318 mA
- Internal active biasing
- Fast power-down/up time of 50 ns
- Easily externally matched
- Compact 4 mm × 4 mm LFCSP
- ESD rating of ±1 kV (Class 1C)

GENERAL DESCRIPTION

The **ADL5604** is a very broadband RF driver amplifier that operates over the wide frequency range of 700 MHz to 2700 MHz. The **ADL5604** is also highly linear and has a very low power consumption, enabling the driver to be packaged in a compact 16-lead, 4 mm × 4 mm LFCSP.

For thermal management, the **ADL5604** uses an exposed paddle, and the upper and lower pins of the package are all grounded, which gives the **ADL5604** excellent thermal transfer characteristics.

The **ADL5604** can be quickly powered down or up in 50 ns for applications requiring TX shutdown, such as TDD systems.

The **ADL5604** operates on a single 5 V supply voltage and draws only 318 mA of supply current.

The driver is fabricated on a GaAs HBT process and operates from -40°C to +85°C. A fully populated evaluation board is available.

FUNCTIONAL BLOCK DIAGRAM

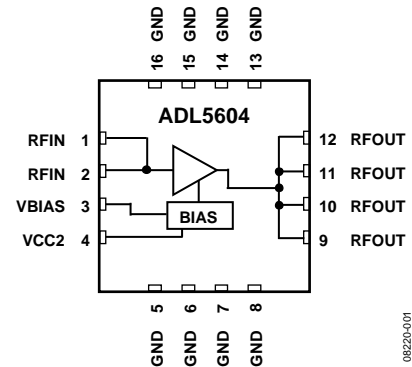

Figure 1.

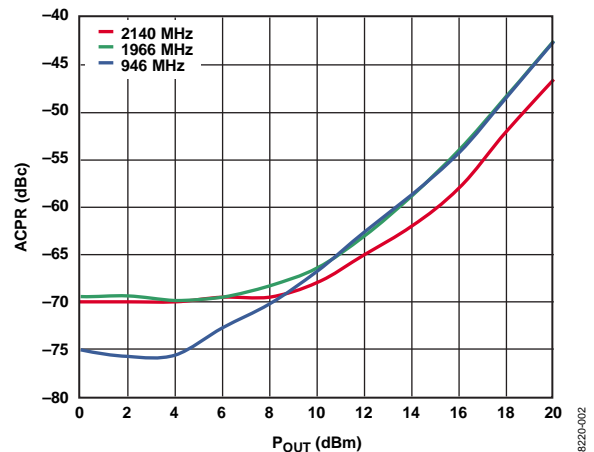

Figure 2. ACPR vs. Output Power, 3GPP 3.5 TM1-64

Rev. C

[Document Feedback](#)

Information furnished by Analog Devices is believed to be accurate and reliable. However, no responsibility is assumed by Analog Devices for its use, nor for any infringements of patents or other rights of third parties that may result from its use. Specifications subject to change without notice. No license is granted by implication or otherwise under any patent or patent rights of Analog Devices. Trademarks and registered trademarks are the property of their respective owners.

TABLE OF CONTENTS

Features	1	Applications Information	15
Functional Block Diagram	1	Basic Layout Connections.....	15
General Description	1	ADL5604 Match	16
Revision History	2	ACPR and EVM	19
Specifications.....	3	Thermal Considerations.....	19
Typical Scattering Parameters.....	5	Soldering Information and Recommended PCB Land	
Absolute Maximum Ratings.....	7	Pattern.....	19
ESD Caution.....	7	Evaluation Board	20
Pin Configuration and Function Descriptions.....	8	Outline Dimensions	23
Typical Performance Characteristics	9	Ordering Guide	23

REVISION HISTORY

8/2017—Rev. B to Rev. C

Changed CP-16-4 to CP-16-23	Throughout
Updated Outline Dimensions	23
Changes to Ordering Guide	23

9/2013—Rev. A to Rev. B

Added Figure 33; Renumbered Sequentially	13
Updated Outline Dimensions	23

2/2011—Rev. 0 to Rev. A

Changes to Figure 29, Figure 30, Figure 31.....	13
Changed L2 Value at 880 MHz to 2.4 nH, Table 6	16
Changes to Figure 41	18
Changes to ACPR and EVM Section	19

4/2010—Revision 0: Initial Version

SPECIFICATIONS

VCC1¹ = 5 V and T_A = 25°C, unless otherwise noted.

Table 1.

Parameter	Test Conditions/Comments	Min	Typ	Max	Unit
OVERALL FUNCTION Frequency Range		700		2700	MHz
FREQUENCY = 748 MHz Gain ² vs. Frequency Output 1 dB Compression Point Output Third-Order Intercept Noise Figure	±20 MHz Δf = 1 MHz, P _{OUT} = 14 dBm per tone		15.3 0.38 29.1 42.8 8.5		dB dB dBm dBm dB
FREQUENCY = 881 MHz Gain ² vs. Frequency Output 1 dB Compression Point Output Third-Order Intercept Noise Figure	±13 MHz Δf = 1 MHz, P _{OUT} = 14 dBm per tone		20.3 0.35 28.8 42.2 4.5		dB dB dBm dBm dB
FREQUENCY = 942 MHz Gain ² vs. Frequency vs. Temperature vs. Supply Output 1 dB Compression Point ACP Output Third-Order Intercept Noise Figure	±18 MHz −40°C ≤ T _A ≤ +85°C 4.75 V to 5.25 V P _{OUT} = 15 dBm, 3GPP 3.5 TM1-64, frequency = 946 MHz Δf = 1 MHz, P _{OUT} = 14 dBm per tone	19.8	20.5 ±0.1 ±0.6 ±0.03 28.3 −56 41.2 3.8	21.3	dB dB dB dB dBm dBm dBm dB
FREQUENCY = 1960 MHz Gain ² vs. Frequency vs. Temperature vs. Supply Output 1 dB Compression Point ACP Output Third-Order Intercept Noise Figure	±30 MHz −40°C ≤ T _A ≤ +85°C 4.75 V to 5.25 V P _{OUT} = 15 dBm, 3GPP 3.5 TM1-64, frequency = 1966 MHz Δf = 1 MHz, P _{OUT} = 14 dBm per tone	13.7	14.4 ±0.2 ±0.7 ±0.02 28.8 −57 42.1 3.6	15.2	dB dB dB dB dBm dBm dBm dB
FREQUENCY = 2140 MHz Gain ² vs. Frequency vs. Temperature vs. Supply Output 1 dB Compression Point ACP Output Third-Order Intercept Noise Figure	±30 MHz −40°C ≤ T _A ≤ +85°C 4.75 V to 5.25 V P _{OUT} = 15 dBm, 3GPP 3.5 TM1-64 Δf = 1 MHz, P _{OUT} = 14 dBm per tone	13.2	14.0 ±0.1 ±0.6 ±0.03 28.6 −60 42.1 3.8	14.9	dB dB dB dB dBm dBm dBm dB

Parameter	Test Conditions/Comments	Min	Typ	Max	Unit
FREQUENCY = 2630 MHz					
Gain ²			12.2		dB
vs. Frequency	±60 MHz		4.8		dB
Output 1 dB Compression Point			29.1		dBm
Output Third-Order Intercept	Δf = 1 MHz, P _{OUT} = 14 dBm per tone		42.2		dBm
Noise Figure			4.6		dB
POWER INTERFACE	Pin RFOUT				
Supply Voltage		4.75	5	5.25	V
Supply Current			318	345	mA
vs. Temperature	-40°C ≤ T _A ≤ +85°C		±7		mA
POWER DOWN INTERFACE					
Turn-On Time	50% of control pulse to 50% of RFOUT		50		ns
Turn-Off Time	50% of control pulse to 50% of RFOUT		50		ns

¹ VCC1 is the supply voltage to the ADL5604 through the RFOUT pins.

² Guaranteed maximum and minimum specified limits on this parameter are based on 6 sigma calculations.

TYPICAL SCATTERING PARAMETERS

VCC1¹ = 5 V and T_A = 25°C; the effects of the test fixture have been de-embedded up to the pins of the device.

Table 2.

Frequency (MHz)	S11		S21		S12		S22	
	Magnitude (dB)	Angle (°)	Magnitude (dB)	Angle (°)	Magnitude (dB)	Angle (°)	Magnitude (dB)	Angle (°)
50	-0.74	-177.7	21.45	134.7	-39.97	10.6	-2.71	-153.2
100	-0.67	-179.4	19.30	134.8	-39.81	6.4	-2.34	-163.2
150	-0.63	179.6	18.18	129.6	-39.69	4.9	-1.93	-167.2
200	-0.59	178.7	17.10	123.5	-39.55	4.0	-1.61	-170.3
250	-0.56	177.9	16.08	117.8	-39.47	3.2	-1.39	-172.9
300	-0.54	177.0	15.12	112.6	-39.53	2.8	-1.26	-175.3
350	-0.53	176.2	14.18	108.2	-39.29	3.4	-1.19	-177.3
400	-0.52	175.4	13.30	104.5	-39.05	1.6	-1.14	-179.0
450	-0.50	174.7	12.51	101.2	-39.02	-1.6	-1.11	179.5
500	-0.50	173.9	11.77	98.3	-39.24	0.3	-1.09	178.0
550	-0.49	173.1	11.09	95.6	-39.27	0.3	-1.10	176.6
600	-0.49	172.4	10.46	93.2	-38.98	0.5	-1.12	175.4
650	-0.48	171.6	9.89	90.9	-38.95	-0.7	-1.11	174.2
700	-0.49	170.8	9.35	88.7	-38.90	-0.5	-1.13	173.0
750	-0.49	170.0	8.85	86.7	-38.78	-1.0	-1.15	172.0
800	-0.49	169.3	8.39	84.7	-38.65	-1.5	-1.18	171.0
850	-0.50	168.5	7.95	82.8	-38.58	-2.3	-1.21	170.0
900	-0.50	167.8	7.55	81.0	-38.51	-2.8	-1.23	169.1
950	-0.51	167.0	7.16	79.2	-38.44	-3.4	-1.27	168.2
1000	-0.51	166.3	6.81	77.5	-38.34	-4.1	-1.28	167.3
1050	-0.52	165.6	6.47	75.8	-38.26	-4.5	-1.32	166.3
1100	-0.53	164.8	6.15	74.0	-38.20	-5.0	-1.35	165.4
1150	-0.54	164.1	5.85	72.4	-38.14	-5.6	-1.39	164.6
1200	-0.55	163.3	5.57	70.8	-38.00	-6.2	-1.43	163.7
1250	-0.56	162.6	5.29	69.2	-37.97	-7.3	-1.47	162.8
1300	-0.57	161.9	5.05	67.7	-37.87	-7.3	-1.50	162.0
1350	-0.58	161.2	4.80	66.1	-37.87	-8.1	-1.55	161.2
1400	-0.59	160.5	4.60	64.6	-37.69	-8.2	-1.57	160.4
1450	-0.59	159.7	4.40	63.0	-37.55	-9.4	-1.60	159.5
1500	-0.60	158.9	4.21	61.4	-37.45	-10.1	-1.64	158.5
1550	-0.61	158.2	4.03	59.9	-37.33	-10.7	-1.68	157.7
1600	-0.63	157.4	3.86	58.2	-37.20	-11.9	-1.74	156.8
1650	-0.64	156.7	3.70	56.7	-37.15	-12.8	-1.78	156.0
1700	-0.65	155.9	3.55	55.1	-37.09	-13.7	-1.82	155.1
1750	-0.67	155.2	3.41	53.6	-36.97	-14.3	-1.88	154.4
1800	-0.68	154.4	3.29	51.9	-36.86	-15.2	-1.92	153.3
1850	-0.69	153.6	3.17	50.3	-36.75	-16.1	-1.97	152.3
1900	-0.70	152.8	3.06	48.6	-36.65	-17.0	-2.02	151.4
1950	-0.72	152.1	2.96	47.0	-36.54	-18.1	-2.10	150.6
2000	-0.73	151.3	2.86	45.3	-36.42	-19.0	-2.17	149.5
2050	-0.75	150.5	2.77	43.7	-36.30	-20.1	-2.23	148.7
2100	-0.77	149.7	2.70	42.0	-36.19	-21.2	-2.31	147.8
2150	-0.78	148.9	2.62	40.4	-36.08	-22.2	-2.40	146.8
2200	-0.80	148.1	2.57	38.7	-35.95	-23.3	-2.45	145.8
2250	-0.82	147.3	2.52	37.0	-35.83	-24.5	-2.51	144.9
2300	-0.84	146.5	2.48	35.1	-35.70	-25.7	-2.61	143.9
2350	-0.86	145.7	2.44	33.4	-35.58	-26.9	-2.72	142.8
2400	-0.88	144.9	2.40	31.5	-35.46	-28.4	-2.81	141.7

Frequency (MHz)	S11		S21		S12		S22	
	Magnitude (dB)	Angle (°)	Magnitude (dB)	Angle (°)	Magnitude (dB)	Angle (°)	Magnitude (dB)	Angle (°)
2450	-0.90	144.1	2.37	29.7	-35.34	-29.8	-2.91	140.8
2500	-0.92	143.2	2.35	27.8	-35.21	-31.0	-3.03	139.7
2550	-0.94	142.4	2.33	26.0	-35.08	-32.5	-3.15	138.7
2600	-0.96	141.6	2.32	24.0	-34.96	-34.0	-3.26	137.7
2650	-0.99	140.8	2.32	22.1	-34.83	-35.5	-3.38	136.7
2700	-1.01	139.9	2.32	20.1	-34.71	-37.2	-3.52	135.6
2750	-1.04	139.1	2.33	18.0	-34.58	-38.8	-3.66	134.4
2800	-1.07	138.3	2.34	15.9	-34.45	-40.5	-3.81	133.3
2850	-1.10	137.4	2.36	13.9	-34.31	-42.2	-3.99	132.3
2900	-1.13	136.6	2.37	11.7	-34.18	-44.1	-4.16	131.1
2950	-1.16	135.7	2.39	9.5	-34.05	-45.9	-4.34	130.1
3000	-1.19	134.9	2.42	7.3	-33.94	-47.9	-4.54	129.0
3050	-1.22	134.1	2.45	5.1	-33.81	-49.9	-4.75	127.9
3100	-1.25	133.2	2.48	2.8	-33.69	-51.9	-4.96	126.9
3150	-1.29	132.4	2.52	0.4	-33.55	-54.0	-5.20	125.8
3200	-1.32	131.5	2.55	-2.0	-33.44	-56.3	-5.45	124.8
3250	-1.36	130.7	2.59	-4.4	-33.32	-58.5	-5.71	123.8
3300	-1.40	129.8	2.63	-6.9	-33.21	-60.8	-5.99	122.7
3350	-1.44	129.0	2.67	-9.4	-33.10	-63.2	-6.29	121.8
3400	-1.47	128.1	2.72	-12.0	-32.98	-65.6	-6.62	120.9
3450	-1.51	127.3	2.76	-14.7	-32.86	-68.0	-6.96	120.0
3500	-1.55	126.4	2.80	-17.3	-32.73	-70.7	-7.31	119.4
3550	-1.59	125.6	2.84	-20.0	-32.61	-73.3	-7.71	118.8
3600	-1.63	124.8	2.89	-22.7	-32.51	-76.1	-8.12	118.2
3650	-1.67	124.0	2.93	-25.5	-32.39	-79.0	-8.57	117.7
3700	-1.71	123.2	2.97	-28.4	-32.28	-82.0	-9.02	117.5
3750	-1.75	122.3	3.01	-31.2	-32.18	-85.1	-9.54	117.6
3800	-1.79	121.5	3.05	-34.1	-32.10	-88.3	-10.09	117.7
3850	-1.82	120.7	3.09	-37.1	-32.02	-91.5	-10.63	118.4
3900	-1.84	119.9	3.13	-40.0	-31.94	-94.8	-11.24	119.5
3950	-1.86	119.1	3.17	-43.0	-31.85	-98.2	-11.86	120.9
4000	-1.88	118.3	3.22	-46.1	-31.79	-101.7	-12.48	123.2

¹ VCC1 is the supply to the ADL5604 through the RFOUT pins.

ABSOLUTE MAXIMUM RATINGS

Table 3.

Parameter	Rating
Supply Voltage, VSUP	6.5 V
Input Power (50 Ω Impedance)	+25 dBm
Internal Power Dissipation (Paddle Soldered)	3.9 W
θ_{JA} (Junction to Air)	32.1°C/W
θ_{JC} (Junction to Paddle)	6°C/W
Maximum Junction Temperature	150°C
Lead Temperature (Soldering, 60 sec)	240°C
Operating Temperature Range	-40°C to +85°C
Storage Temperature Range	-65°C to +150°C

Stresses at or above those listed under Absolute Maximum Ratings may cause permanent damage to the product. This is a stress rating only; functional operation of the product at these or any other conditions above those indicated in the operational section of this specification is not implied. Operation beyond the maximum operating conditions for extended periods may affect product reliability.

ESD CAUTION



ESD (electrostatic discharge) sensitive device. Charged devices and circuit boards can discharge without detection. Although this product features patented or proprietary protection circuitry, damage may occur on devices subjected to high energy ESD. Therefore, proper ESD precautions should be taken to avoid performance degradation or loss of functionality.

PIN CONFIGURATION AND FUNCTION DESCRIPTIONS

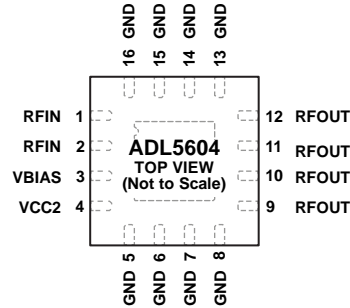

NOTES
 1. THE PADDLE SHOULD BE CONNECTED TO BOTH THERMAL AND ELECTRICAL GROUND.

08/22/0-003

Figure 3. Pin Configuration

Table 4. Pin Function Descriptions

Pin No.	Mnemonic	Description
1, 2	RFIN	RF Input. Requires a dc blocking capacitor.
5, 6, 7, 8, 13,14, 15, 16	GND	Solder to a low impedance electrical and thermal ground plane.
3	VBIAS	Dual Function Pin. Applying 5 V to this pin enables the bias circuit. Grounding this pin disables the device. When VBIAS is used alone to disable the ADL5604 , the disable current is 13 mA.
4	VCC2	Under normal operation, this pin is connected to the power supply and draws approximately 5 mA of current. This pin can be grounded with the VBIAS pin to allow a disable current of <1 μ A.
9, 10, 11, 12	RFOUT	RF Output and Main Supply Voltage. DC bias is provided to this pin through an inductor that is connected to the 5 V power supply. The RF path requires a dc blocking capacitor.
	EP	The exposed paddle is connected internally to ground. Solder to a low impedance electrical and thermal ground plane.

TYPICAL PERFORMANCE CHARACTERISTICS

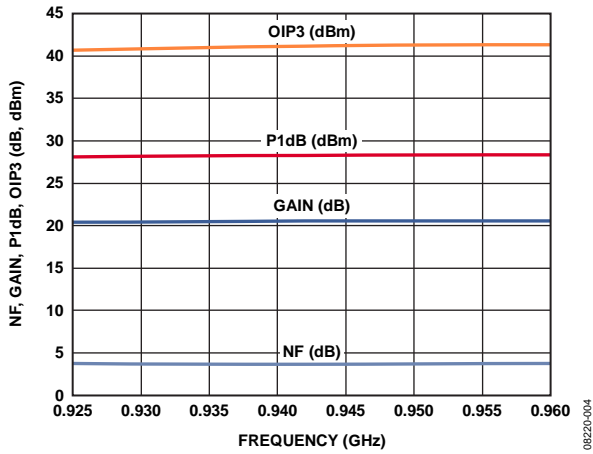

Figure 4. Gain, P1dB, OIP3 at $P_{OUT} = 14$ dBm/Tone and Noise Figure vs. Frequency

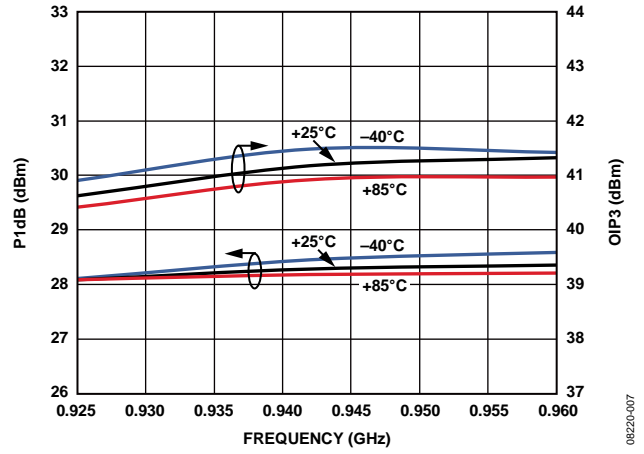

Figure 7. OIP3 at $P_{OUT} = 14$ dBm/Tone and P1dB vs. Frequency and Temperature

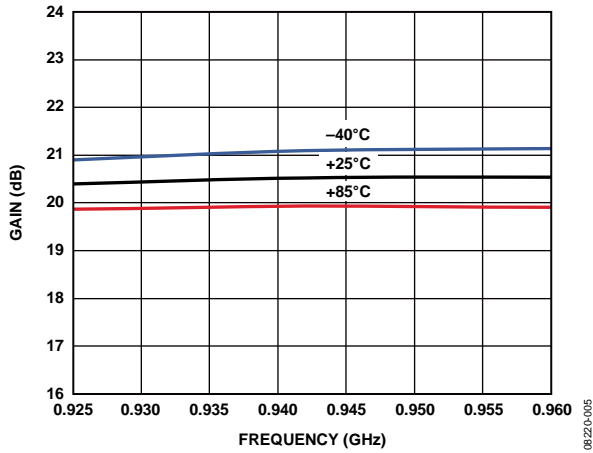

Figure 5. Gain vs. Frequency and Temperature

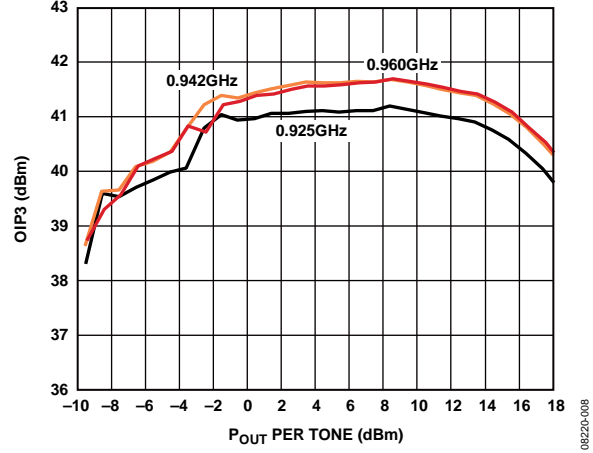

Figure 8. OIP3 vs. P_{OUT} and Frequency

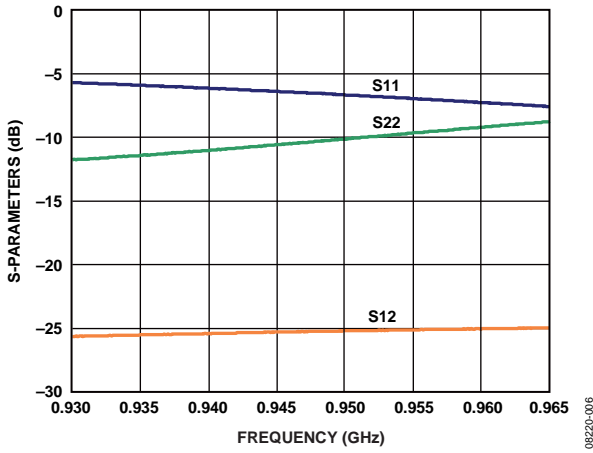

Figure 6. Input Return Loss (S11), Output Return Loss (S22), and Reverse Isolation (S12) vs. Frequency

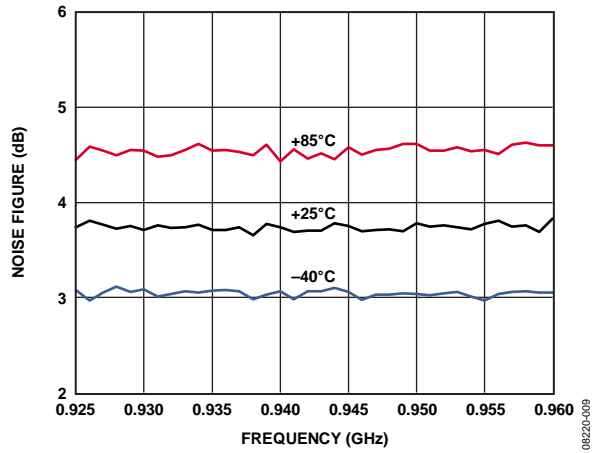

Figure 9. Noise Figure vs. Frequency and Temperature

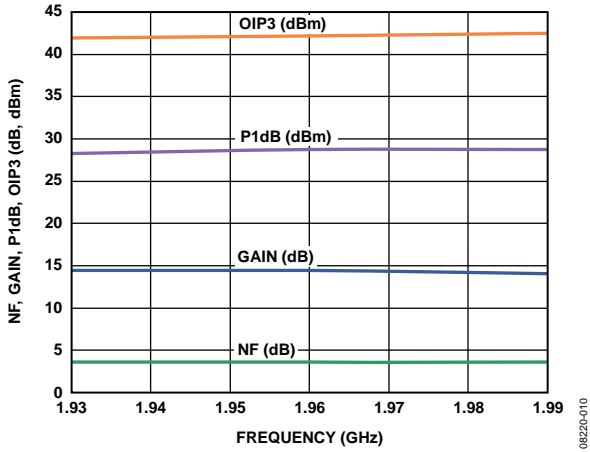

Figure 10. Gain, P1dB, OIP3 at $P_{OUT}=14$ dBm/Tone and Noise Figure vs. Frequency

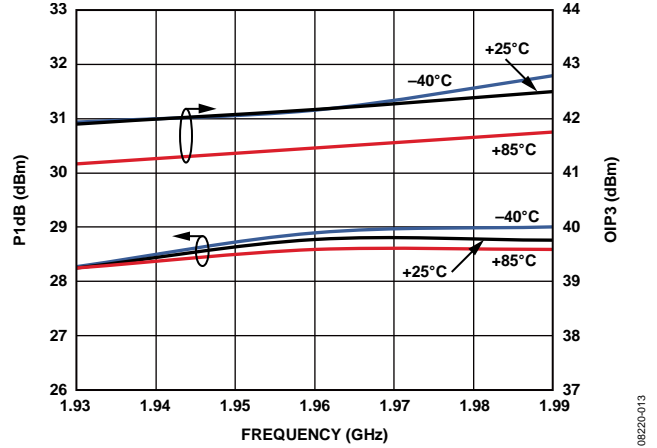

Figure 13. OIP3 at $P_{OUT}=14$ dBm/Tone and P1dB vs. Frequency and Temperature

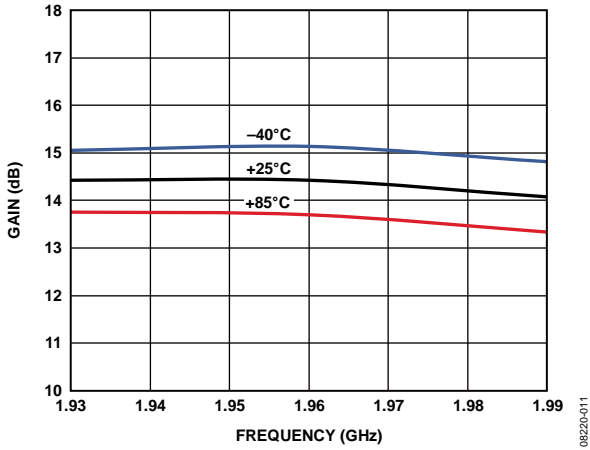

Figure 11. Gain vs. Frequency and Temperature

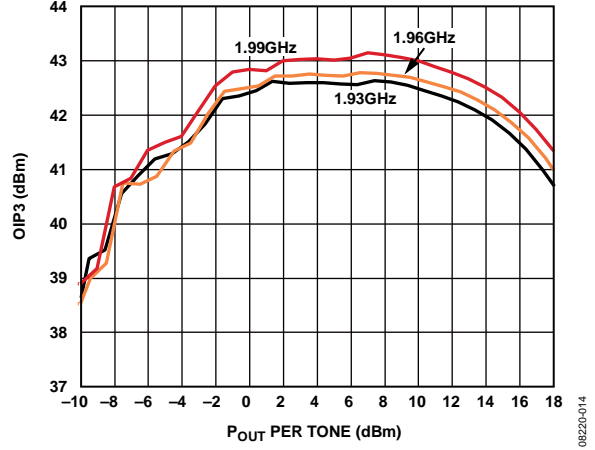

Figure 14. OIP3 vs. P_{OUT} and Frequency

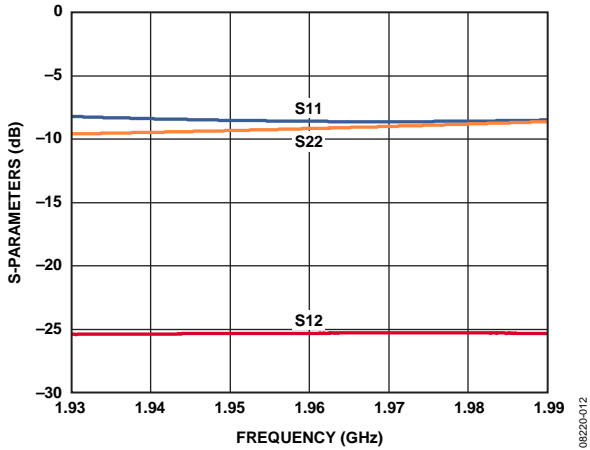

Figure 12. Input Return Loss (S11), Output Return Loss (S22), and Reverse Isolation (S12) vs. Frequency

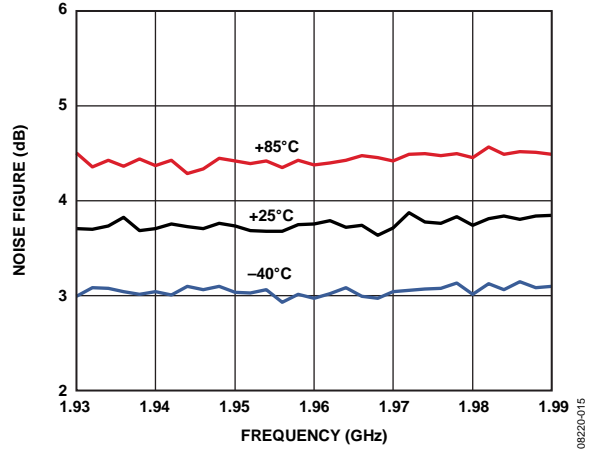

Figure 15. Noise Figure vs. Frequency and Temperature

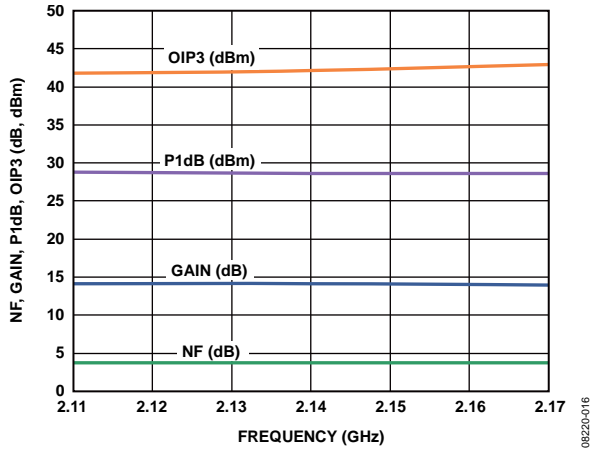

Figure 16. Gain, P1dB, OIP3 at $P_{OUT}=14$ dBm/Tone and Noise Figure vs. Frequency

08220-016

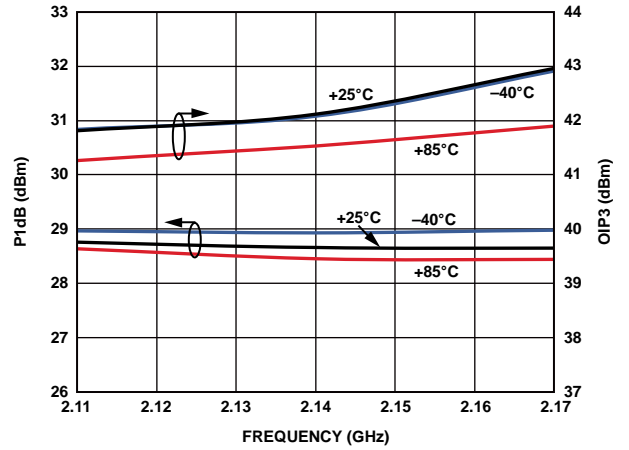

Figure 19. OIP3 at $P_{OUT}=14$ dBm/Tone and P1dB vs. Frequency and Temperature

08220-019

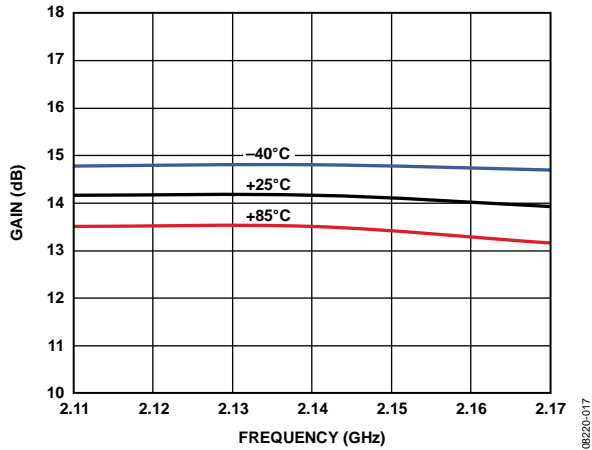

Figure 17. Gain vs. Frequency and Temperature

08220-017

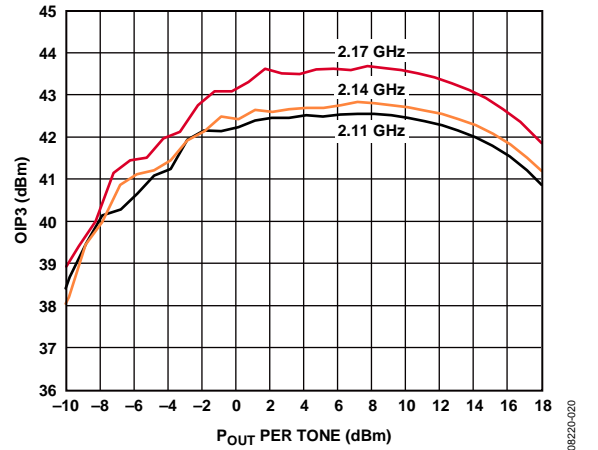

Figure 20. OIP3 vs. P_{OUT} and Frequency

08220-020

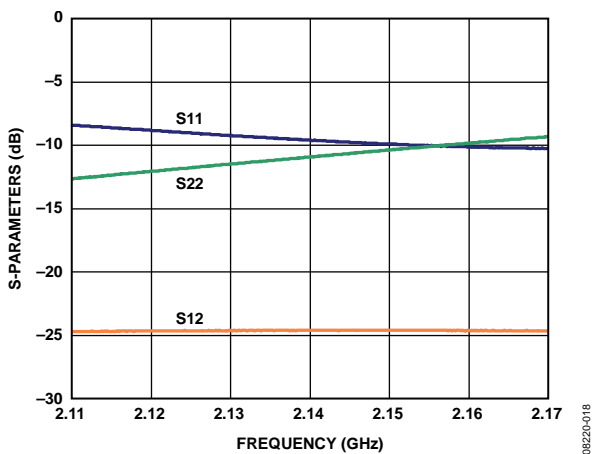

Figure 18. Input Return Loss (S11), Output Return Loss (S22), and Reverse Isolation (S12) vs. Frequency

08220-018

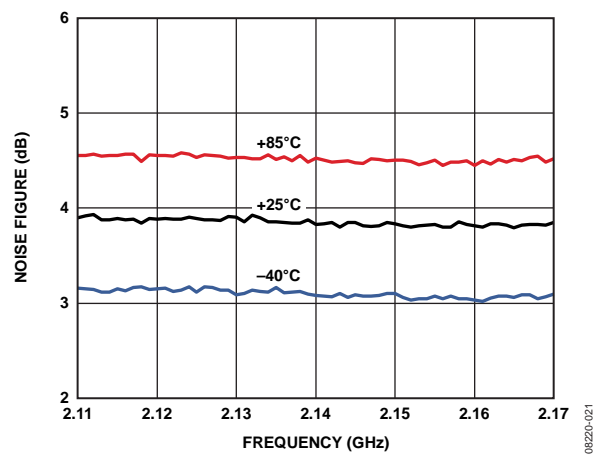

Figure 21. Noise Figure vs. Frequency and Temperature

08220-021

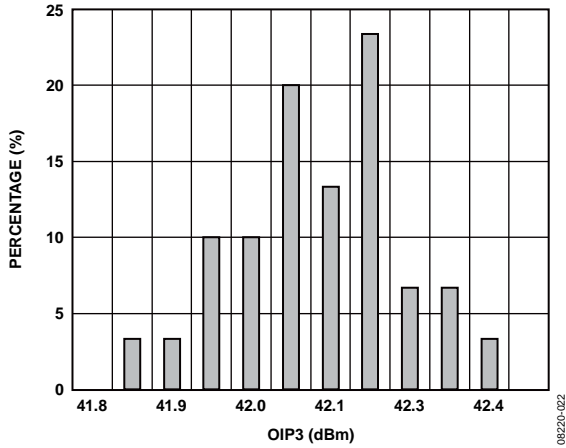

Figure 22. OIP3 Distribution at 2140 MHz

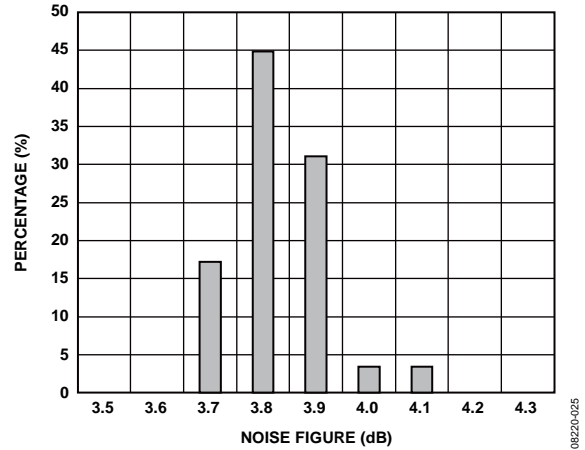

Figure 25. Noise Figure Distribution at 2140 MHz

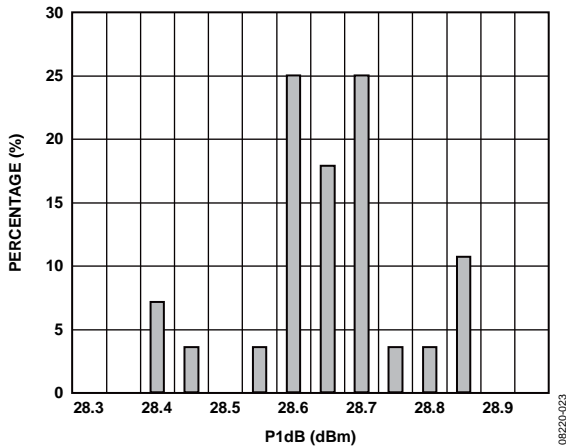

Figure 23. P1dB Distribution at 2140 MHz

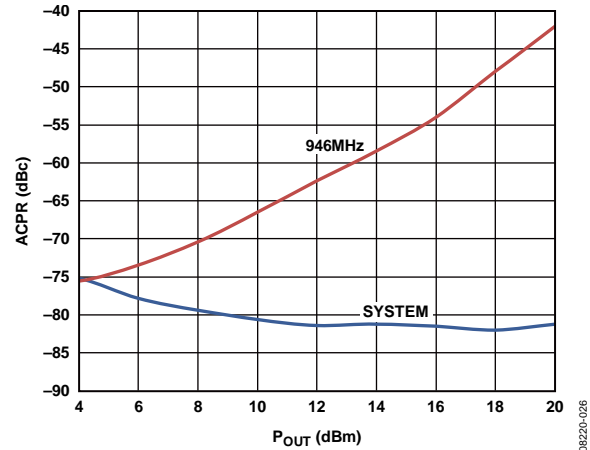

Figure 26. ACPR vs. P_{OUT} , 3GPP 3.5 TM1-64 at 946 MHz

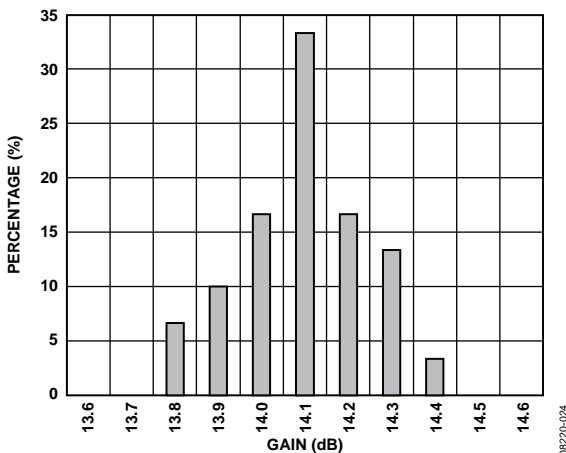

Figure 24. Gain Distribution at 2140 MHz

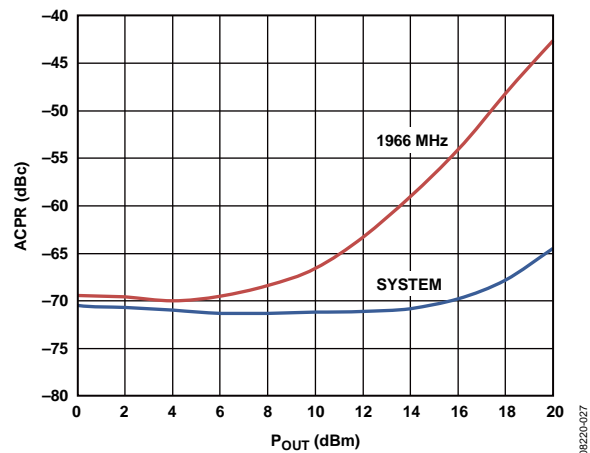

Figure 27. ACPR vs. P_{OUT} , 3GPP 3.5 TM1-64 at 1966 MHz

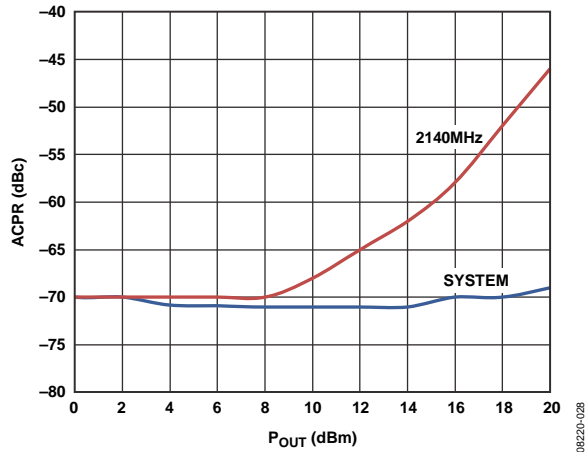

Figure 28. ACPR vs. P_{OUT} , 3GPP 3.5 TM1-64 at 2140 MHz

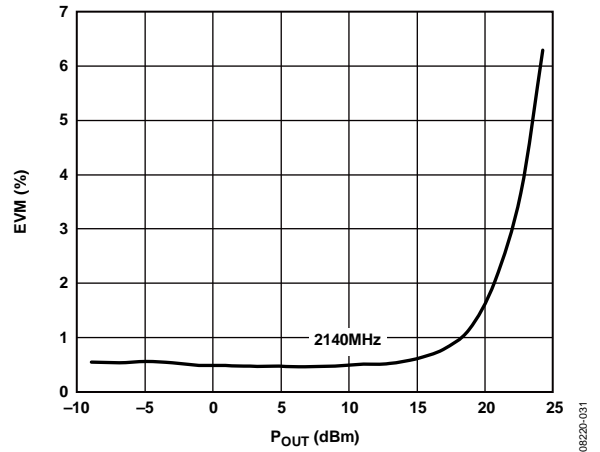

Figure 31. EVM vs. P_{OUT} at 2140 MHz

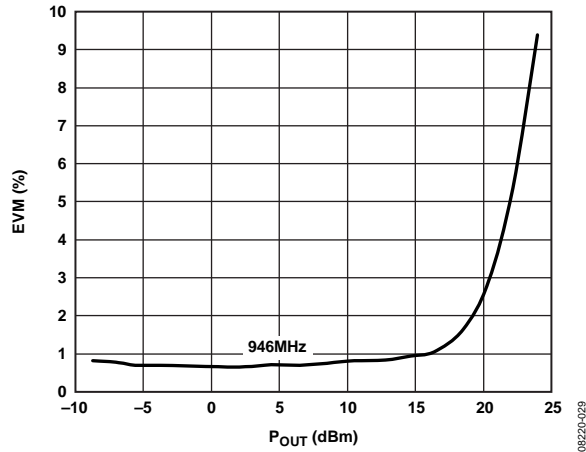

Figure 29. EVM vs. P_{OUT} at 946 MHz

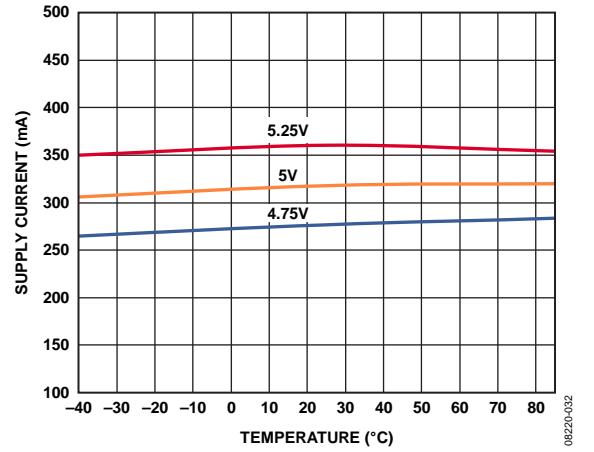

Figure 32. Supply Current vs. Supply Voltage and Temperature at 2140 MHz

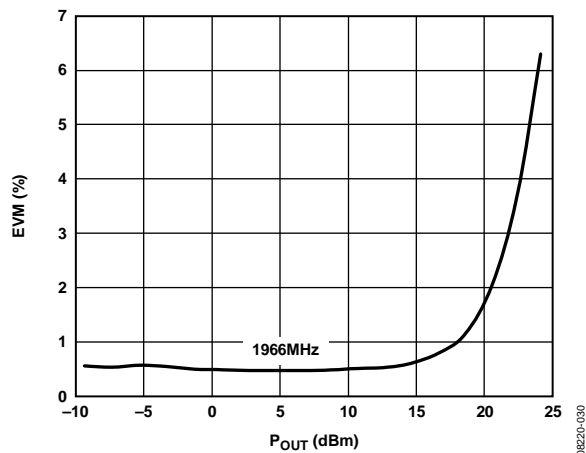

Figure 30. EVM vs. P_{OUT} at 1966 MHz

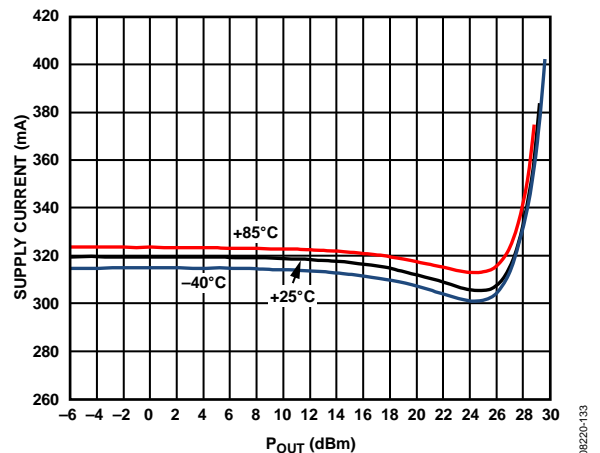

Figure 33. Supply Current vs. P_{OUT} and Temperature, $V_{CC} = 5V$ at 2140 MHz

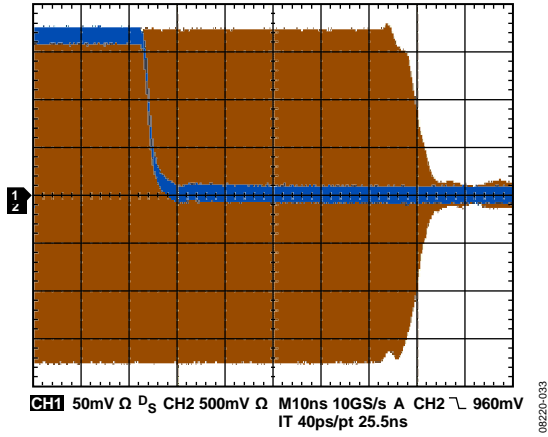

Figure 34. Turn-Off Time, 50% of Control Pulse to 50% of RF Burst

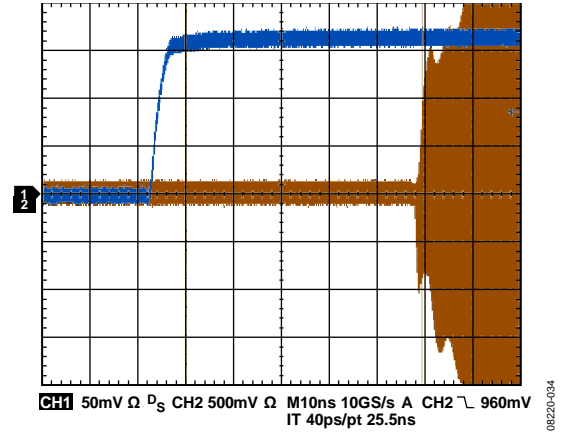
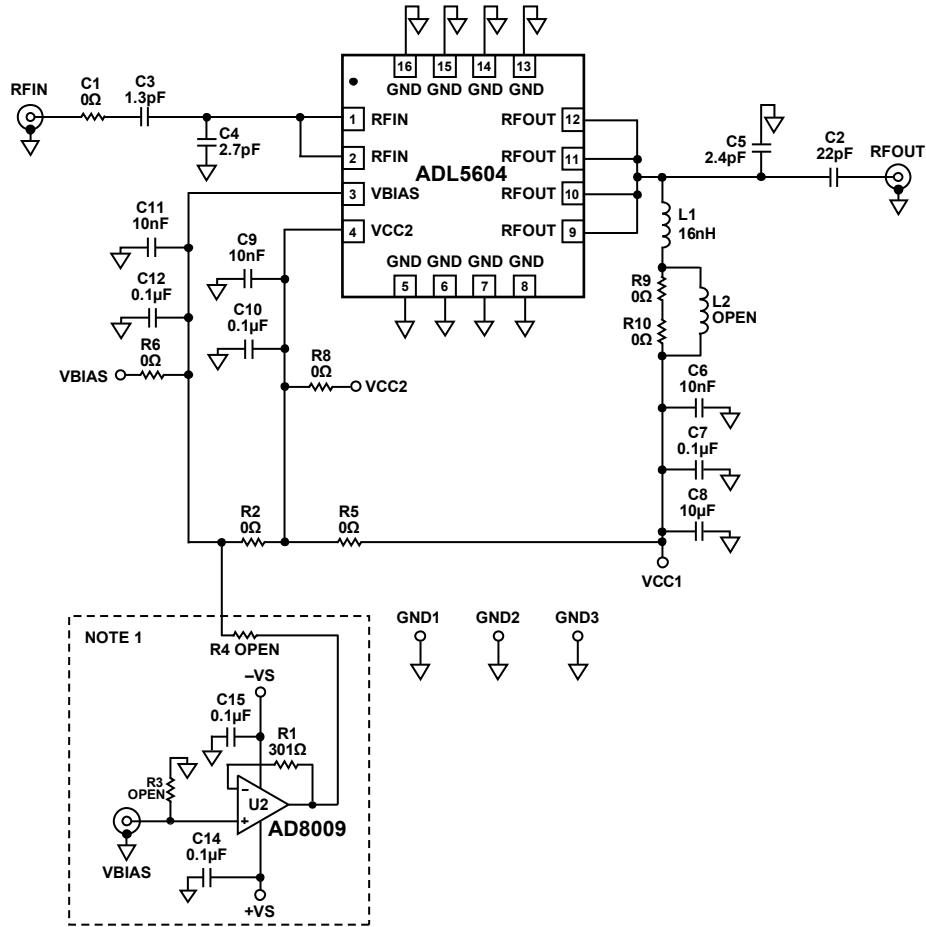

Figure 35. Turn-On Time, 50% of Control Pulse to 50% of RF Burst

APPLICATIONS INFORMATION

BASIC LAYOUT CONNECTIONS

The basic connections for operating the ADL5604 are shown in Figure 36.



NOTES
 1. THE COMPONENTS CONTAINED INSIDE THE DASHED BOX ARE ONLY REQUIRED IF IT IS DESIRED TO POWER DOWN THE ADL5604.

082201-0335

Figure 36. Basic Connections

Power Supply

The voltage supply for the ADL5604, which ranges from 4.75 V to 5.25 V, should be connected to the VCC1 pin. The dc bias to the output stage is supplied through L1 and is connected to the RFOUT pin. Three decoupling capacitors, C6, C7, and C8, are used to prevent RF signals from propagating on the dc lines. The VBIAS and VCC2 pins are connected to the main supply voltage, VCC1, through the R2 and R5 resistors. Additional decoupling capacitors, C9, C10, C11, and C12, are required on the VCC2 and VBIAS pins.

RF Input Interface

Pin 1 and Pin 2 are the RF input pins for ADL5604. The RF input is easily matched with two or three components and a

microstrip line used as an inductor. If additional inductance is required, C3 can be replaced with an inductor. See the ADL5604 Match section for the component values and spacing for the different frequency bands.

RF Output Interface

Pin 9 to Pin 12 are used as the RF output pins. The C5 shunt capacitor and the inductance from the microstrip line match RF output to 50 Ω. See the ADL5604 Match section for the component values and spacing for the different frequency bands.

Power-Down Circuit

Device U2 and its associated circuitry can be used to power down the ADL5604. To connect U2, remove the R2 resistor and place a 0 Ω resistor in place of R4.

ADL5604 MATCH

The ADL5604 is easily matched with three matching components and a microstrip line used as inductance. If spacing is tight, an external inductor can take the place of the microstrip line. The output match includes a short (76 mils, including the portion that is used as the pad for the chip) non 50 Ω line to accommodate the four output pins and allow for easier low inductance output matching. The pads for Pin 9 to Pin 12 are included on this microstrip line, as well as the pad for the L1 bias inductor.

The extended length allows the bias inductor to be placed close to the chip, where the impedance is lowest, while allowing a low inductance path to a shunt capacitor to ground. This extra length allows for alternative matching but is also included in the output match at all frequencies. Table 5 and Table 6 detail the component spacing and values for the input and output matching networks for the ADL5604 for the different frequencies. Figure 37 through Figure 42 show the matching networks.

Table 5. Component Spacing

Frequency	λ1 (mils)	λ2 (mils)	λ3 (mils)	λ4 (mils)	λ5 (mils)
748 MHz	67	348	41	272	106
880 MHz	75	138	41	181	154
943 MHz	N/A	118	41	220	95
1960 MHz	35	N/A	41	232	N/A
2140 MHz	45	182	41	197	N/A
2630 MHz	55	182	41	126	N/A

Table 6. Component Values

Frequency	C1 (pF)	C2 (pF)	C3 (pF)	C4 (pF)	C5 (pF)	L1 (nH)	L2 (nH)	Lout (nH)
748 MHz	100 pF	100 pF	10.0 pF	20.0 pF	7.0 pF	16 nH	N/A	2.7 nH
880 MHz	100 pF	100 pF	N/A	9.0 pF	6.0 pF	16 nH	2.4 nH	3.6 nH
943 MHz	100 pF	100 pF	12.0 pF	N/A	6.2 pF	16 nH	N/A	3.0 nH
1960 MHz	22 pF	22 pF	0 Ω	4.3 pF	2.2 pF	16 nH	N/A	N/A
2140 MHz	0 Ω	22 pF	1.3 pF	2.7 pF	2.4 pF	16 nH	N/A	N/A
2630 MHz	22 pF	22 pF	N/A	2.2 pF	1.8 pF	16 nH	4.3 nH	N/A

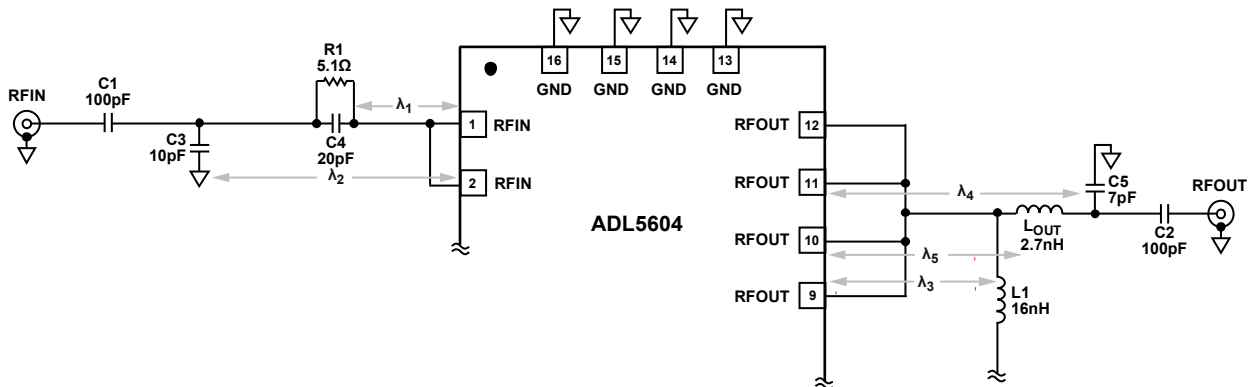

Figure 37. ADL5604 Match Parameters, 748 MHz

08220-037

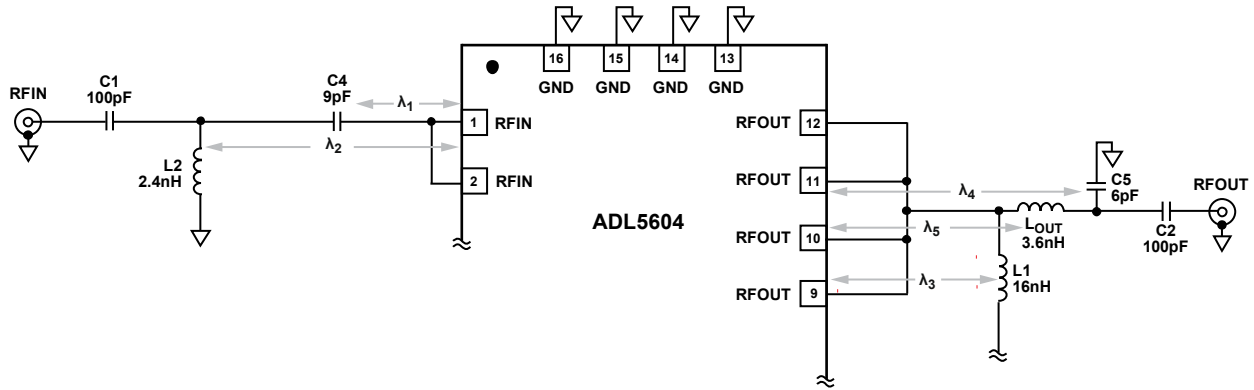

Figure 38. ADL5604 Match Parameters, 880 MHz

08220-038

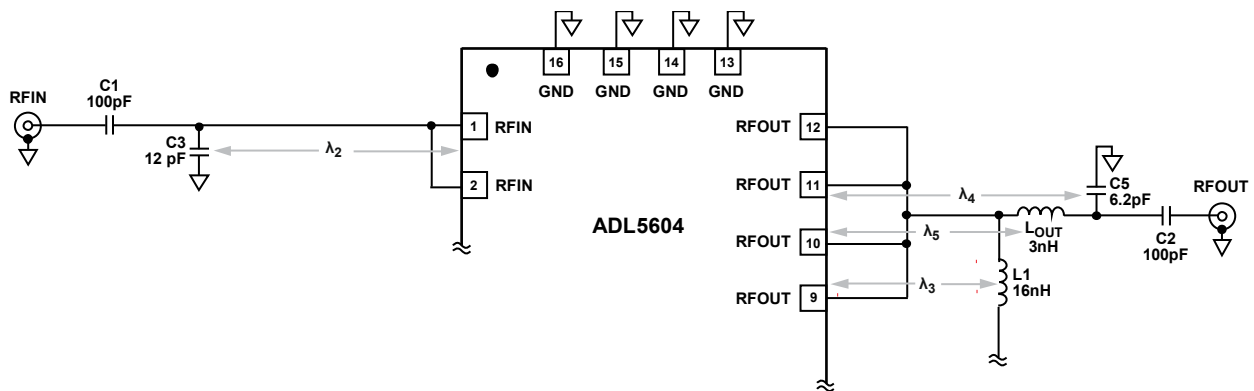

Figure 39. ADL5604 Match Parameters, 943 MHz

08220-039

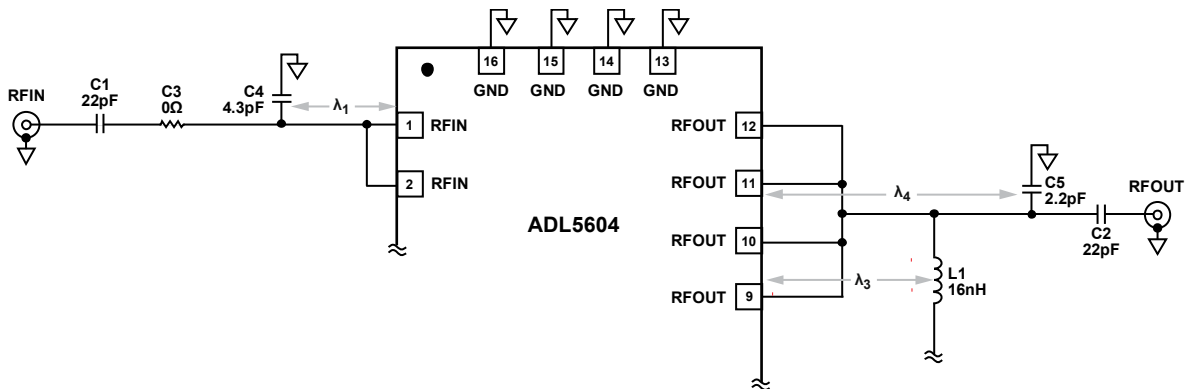

Figure 40. ADL5604 Match Parameters, 1960 MHz

08220-040

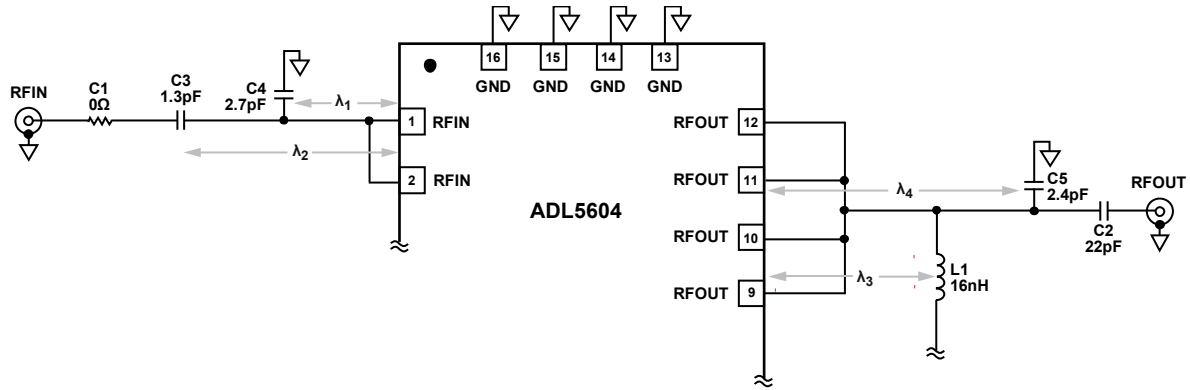

Figure 41. ADL5604 Match Parameters, 2140 MHz

08220-041

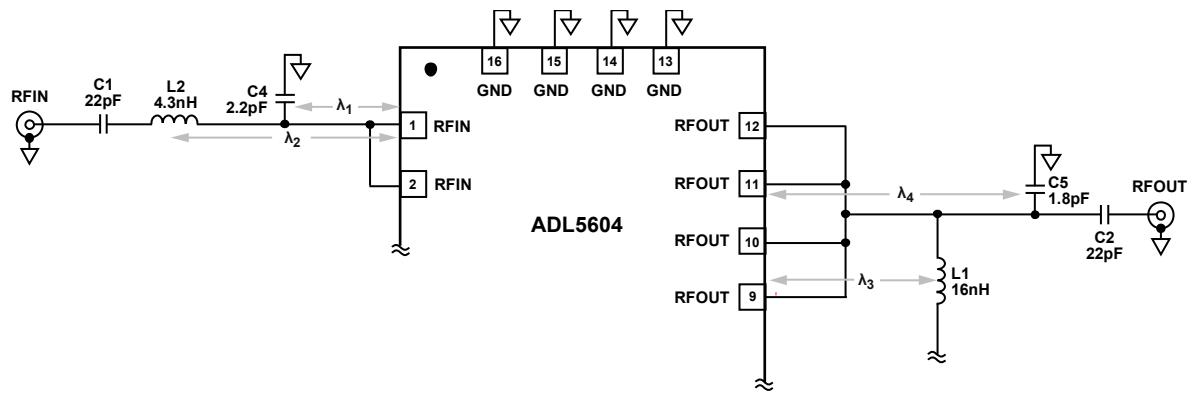

Figure 42. ADL5604 Match Parameters, 2630 MHz

08220-042

ACPR AND EVM

All adjacent channel power ratio (ACPR) and error vector magnitude (EVM) measurements were made using a single W-CDMA carrier and Test Model 1-64.

The signal is generated by a very low ACPR source and is measured at the output by a high dynamic range spectrum analyzer. For ACPR measurements, the filter setting was chosen for low ACPR and for EVM measurements the low EVM setting was selected. The baseline composite EVM for the signal source used was around 0.5%. Highly linear amplifiers were used to measure ACPR and EVM at higher output power levels.

Figure 26 shows the plot of ACPR vs. P_{OUT} at 946 MHz. Shown on the same plot is the system ACPR. For power levels up to 11 dBm, an ACPR of 65 dBc or better can be achieved.

Figure 27 shows the ACPR vs. P_{OUT} at 1966 MHz. Shown on the same plot is the system ACPR. For power levels up to 11 dBm, an ACPR of 65 dBc or better can be achieved.

Figure 28 shows ACPR vs. P_{OUT} at 2140 MHz. Shown on the same plot is the system ACPR. For power levels up to 12 dBm, an ACPR of 65 dBc or better can be achieved. Figure 29 shows the plot of EVM vs. P_{OUT} at 946 MHz. The EVM measured is less than 1% for power levels up to 15 dBm.

Figure 30 shows the EVM vs. P_{OUT} at 1966 MHz. The EVM measured is less than 1% for power levels up to 18 dBm. Figure 31 shows the EVM vs. P_{OUT} at 2140 MHz. The EVM measured is less than 1% for power levels up to 18 dBm.

When operated in the linear region, there is little or no contribution to EVM by the amplifier.

THERMAL CONSIDERATIONS

The ADL5604 is packaged in a thermally efficient 4 mm × 4 mm, 16-lead LFCSP. The thermal resistance from junction to air (θ_{JA}) is 32.1°C/W. The thermal resistance for the product was extracted assuming a standard 4-layer JEDEC board with nine copper filled thermal vias. The thermal resistance from junction to case (θ_{JC}) is 6°C/W where case is the exposed pad of the lead frame package.

For the best thermal performance, it is recommended to add as many thermal vias as possible under the exposed pad of the

LFCSP. The above thermal resistance numbers assume a minimum of nine thermal vias arranged in a 3 × 3 array with a diameter of 8 mils and a pitch of 16 mils. Because the top and bottom leads of the package are ground, the ground pattern on the evaluation board is extended on the top and bottom to improve thermal efficiency (see the Evaluation Board section).

SOLDERING INFORMATION AND RECOMMENDED PCB LAND PATTERN

Figure 43 shows the recommended land pattern for the ADL5604. To minimize thermal impedance, the exposed paddle on the 4 mm × 4 mm LFCSP package is soldered down to a ground plane along with Pin 5 to Pin 8 and Pin 13 to Pin 16. To improve thermal dissipation, nine thermal vias are arranged in a 3 × 3 array under the exposed paddle. Areas above and below the paddle are tied with regular vias. If multiple ground layers exist, they should be tied together using vias. For more information on land pattern design and layout, see the AN-772 Application Note, *A Design and Manufacturing Guide for the Lead Frame Chip Scale Package (LFCSP)*.

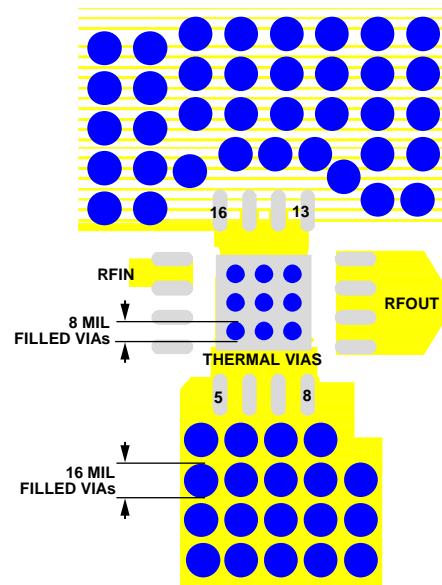

Figure 43. Recommended Land Pattern

082201-043

EVALUATION BOARD

The schematic of the **ADL5604** evaluation board is shown in Figure 44. This evaluation board uses 25 mils wide, 50 Ω traces and is made from IS410 material, with a 23 mils gap to ground. The evaluation board is tuned for operation at 2140 MHz. The inputs and outputs should be ac-coupled with appropriately sized capacitors; therefore, for low frequency applications, C1 and C2 may need to be increased. DC bias is provided to the output stage via an inductor connected to the RFOUT pin. A bias voltage of 5 V is recommended. The evaluation board has a short non 50 Ω line on its output to accommodate the four output pins and allow for easier low inductance output matching. The pads for Pin 9 to Pin 12 are included on this microstrip line

and are included in all matches. Figure 47 shows the close-up image of the recommended output pad. The evaluation board also has hash marks close to the input and output of the **ADL5604**, separated by 40 mils. The hash mark closest to the input is 127 mils from the chip, and the hash mark closest to the output is 20 mils from the chip.

U2 and its associated circuitry are required only if it is desired to power down the **ADL5604**. On the evaluation board, it is necessary to remove R2 and install a 0 Ω resistor in the R4 position to enable this feature.

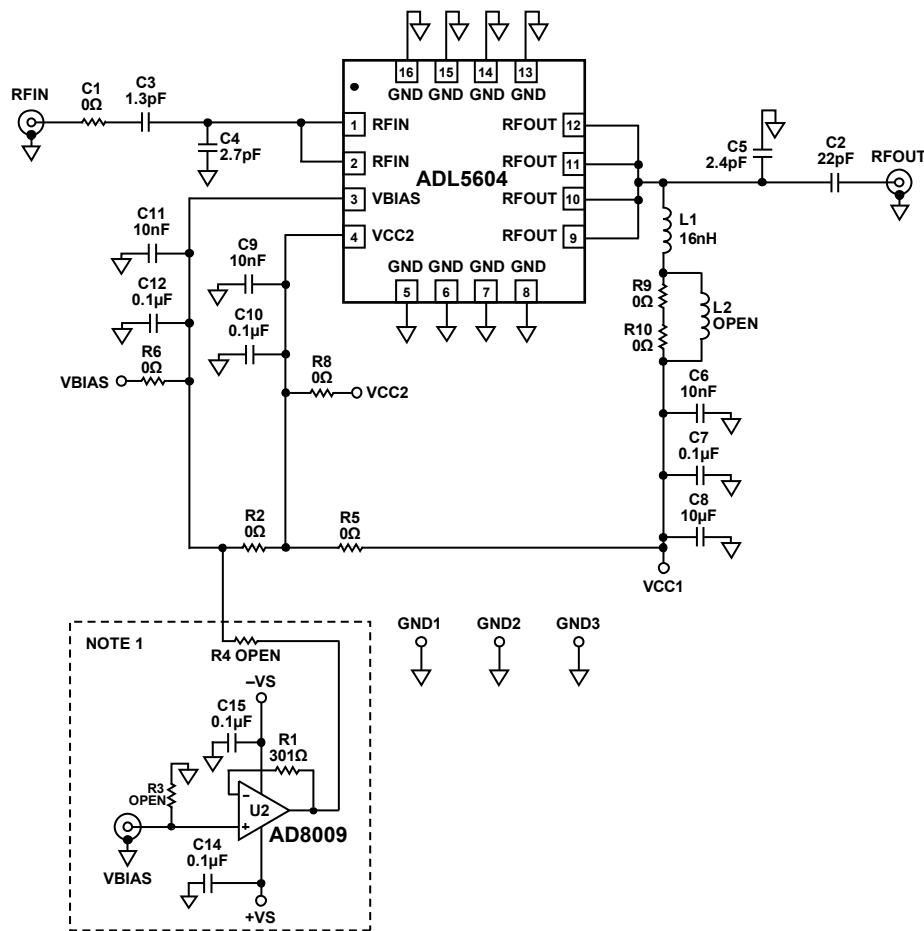

NOTES
 1. THE COMPONENTS CONTAINED INSIDE THE DASHED BOX ARE ONLY REQUIRED IF IT IS DESIRED TO POWER DOWN THE ADL5604.

Figure 44. Evaluation Board, 2140 MHz

08220-044

Table 7. Evaluation Board Configuration Options, 2140 MHz

Component	Function/Notes	Default Value
C1, C2	Input/output dc blocking capacitors at 2140 MHz. C3 provides dc blocking; therefore, a jumper is installed in place of C1.	C1 = 0 Ω , C2 = 22 pF
C3, C4	Input matching capacitors. The input match is set for 2140 MHz but is easily changed for other frequencies. C3 is set at a specific distance from C4 so that the microstrip line can act as inductance for part of the match. If space is at a premium, an inductor can take the place of the microstrip line. The ADL5604 is sensitive to the input match; therefore, the tolerance of these components and their placement must be tight.	C3 = 1.3 pF HQ, C4 = 2.7 pF HQ
C5	Output matching capacitor. The output match is set for 2140 MHz but is easily changed for other frequencies. The tolerance for this capacitor should be tight. C5 is set at a specific distance from the input; therefore, the microstrip line can act as inductance for part of the match. If space is at a premium, an inductor can take the place of the microstrip line. There is a short length of low impedance line on the output that is embedded in the match. The ADL5604 is less sensitive to the output match than the input match, but the tolerance still must be tight.	C5 = 2.4 pF
L1, L2, R9, R10	The main bias for the ADL5604 comes through L1 to its output. L1 should be high impedance for the frequency of operation, while providing low resistance for the dc current. The evaluation board uses a Coilcraft 0603HP-16NX_H inductor. It is a 16 nH inductor, which provides some of the match at 2140 MHz. As the operating frequency gets lower, the inductance must increase, but as the inductance increases, the current is more limited for a 0603 package. R9 and R10 can be removed and L2 added to allow for low frequency operation. L2 has the footprint for a Coilcraft SLC7530D-101MLB (0.4 μ H).	L1 = 16 nH, L2 = open, R9 = 0 Ω , R10 = 0 Ω
C6, C7, C8, C9, C10, C11, C12, C14, C15	Power supply decoupling. The need for power supply decoupling capacitance is based on the noise and potential for noise on the power supply. The smallest capacitor should be the closest to the ADL5604. The main bias that goes through RFOUT is the most sensitive to noise because the bias is connected directly to the output.	C6, C9, C11 = 10 nF, C7, C10, C12, C14, C15 = 0.1 μ F, C8 = 10 μ F
R6, R8	R6 and R8 can be removed to eliminate any parasitic elements of VBIAS and VCC2 if a fast response time is required.	R6 = 0 Ω , R8 = 0 Ω
R2, R4, R5	The ADL5604 can be shut down using VBIAS alone or VBIAS and VCC2. The ADL5604 has a shutdown current of 13 mA when only VBIAS is used. The shutdown current is < 1 μ A if VBIAS and VCC2 are used. However, VCC2 draws 5 mA when biased, setting the current drive capability of the shutdown controller. R2, R4, and R5 allow custom configuration of the shutdown.	R2, R5 = 0 Ω , R4 = open
U2, R1, R3	If VCC2 is used to shut down the ADL5604, 5 mA must be sourced when the part is enabled. U2, R1, and R3 are configured as a buffer to source the 5 mA.	U2 = AD8009, R1 = 3.01 Ω , R3 = open
Exposed Paddle	The paddle should be connected to both thermal and electrical ground.	

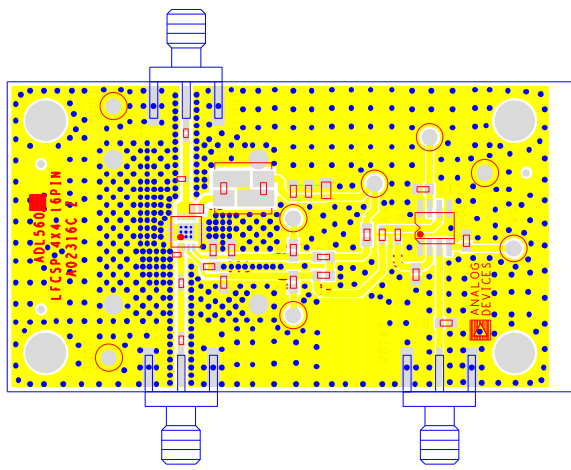

Figure 45. Evaluation Board Layout, Topside

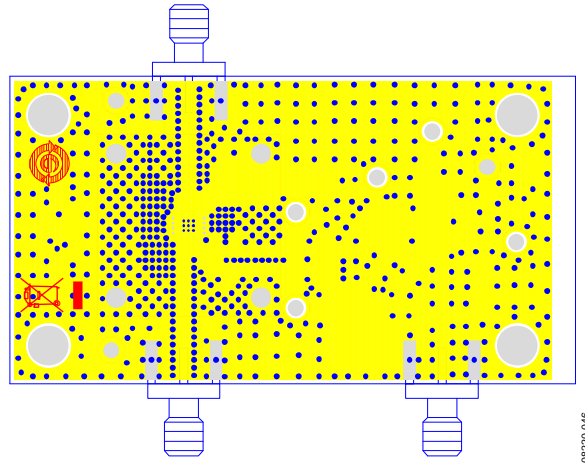

Figure 46. Evaluation Board Layout, Bottom Side

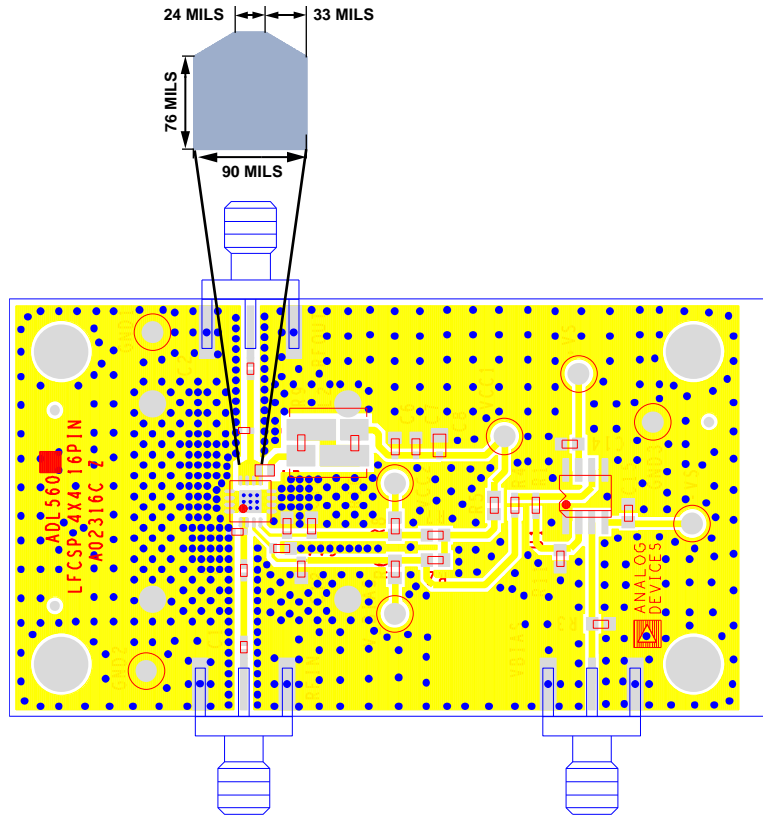
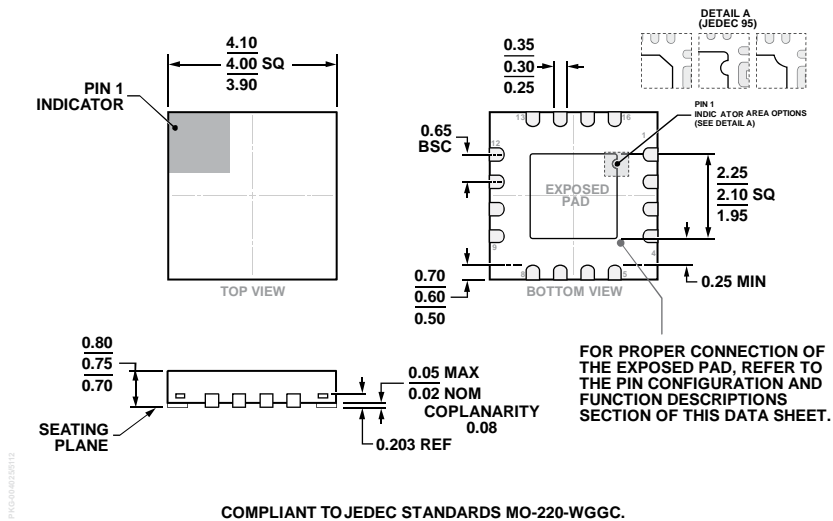

Figure 47. Evaluation Board Layout, Output Pad

OUTLINE DIMENSIONS



COMPLIANT TO JEDEC STANDARDS MO-220-WGGC.

Figure 48. 16-Lead Lead Frame Chip Scale Package [LFCSP]
 4 mm × 4 mm Body and 0.75 mm Package Height
 (CP-16-23)
 Dimensions shown in millimeters

ORDERING GUIDE

Model ¹	Temperature Range	Package Description	Package Option
ADL5604ACPZ-R7	-40°C to +85°C	16-Lead Lead Frame Chip Scale Package [LFCSP]	CP-16-23
ADL5604-EVALZ		Evaluation Board	

¹ Z = RoHS Compliant Part.

Looking for pricing, stock, or lifecycle information?

Click below to explore more details on WIN SOURCE:

 [View ADL5604ACPZ-R7 on WIN SOURCE](#)

 [Analog Devices Inc. Information](#)

Optimize Your Supply Chain with WIN SOURCE Solutions

-  Global Sourcing Solution
-  Obsolete Management
-  Cost Control Management
-  Shortage Management
-  Alternative Solution
-  Excess Inventory Management