



**THE DATASHEET OF
PMA-5456+**





LOW NOISE, HIGH IP3

Monolithic Amplifier

PMA-5456+

50Ω 0.05 to 6 GHz

THE BIG DEAL

- Ultra Low Noise Figure, 0.8 dB
- High IP3, 34 dBm typ. 1GHz
- Wideband, up to 6 GHz
- Low Additive Phase Noise
- Suitable for low phase noise applications

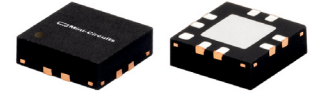

Generic photo used for illustration purposes only

CASE STYLE: DQ849

APPLICATIONS

- Cellular
- ISM
- GSM
- WCDMA
- LTE
- WiMAX
- WLAN
- UNII and HIPERLAN

+RoHS Compliant

The +Suffix identifies RoHS Compliance. See our web site for RoHS Compliance methodologies and qualifications

PRODUCT OVERVIEW

PMA-5456+ is a high dynamic range, low noise, high IP3, high output power, monolithic amplifier. Manufactured using E-PHEMT* technology enables it to work with a single positive supply voltage. Unconditionally stable over the operating frequency.

KEY FEATURES

Feature	Advantages
Ultra Low Noise, 0.8 dB	Outstanding Noise Figure, measured in a 50 Ohm environment without any external matching
High IP3, 34 dBm	Combining Low Noise and High IP3 makes this MMIC amplifier ideal for Low Noise Receiver Front End (RFE) because it gives the user advantages at both ends of the dynamic range: sensitivity & two-tone spur-free dynamic range
Low Current, 60 mA	At only 60mA, the PMA-5456+ is ideal for remote applications with limited available power or densely packed applications where thermal management is critical.
Broad Band	Operating over a broadband the PMA-5456+ covers the primary wireless communications bands: Cellular, PCS, LTE, WiMAX
Internally Matched	No external matching elements required to achieve the advertised noise and output power over the full band
MCLP Package	Low Inductance, repeatable transitions, excellent thermal pad
Max Input Power, +20 dBm	Ruggedized design operates up to input powers of +20 dBm without the need of an external limiter
High Reliability	Low, small signal operating current of 60mA nominal maintains junction temperatures typically below 125°C at 85°C ground lead temperature
Low additive phase noise, typically -161 dBc/Hz @10 KHz offset	Ideal for low phase noise synthesizer applications

*Enhancement mode Pseudomorphic High Electron Mobility Transistor

REV. G
ECO-011027
PMA-5456+
TH/RS/CP/AM
211203





LOW NOISE, HIGH IP3

Monolithic Amplifier

PMA-5456+

Mini-Circuits

ELECTRICAL SPECIFICATIONS⁽¹⁾ AT 25°C, ZO=50Ω (REFER TO CHARACTERIZATION CIRCUIT, SEE FIG. 1)

Parameter	Condition (GHz)	Min.	Typ.	Max.	Units
Frequency Range		0.05		6.0	GHz
DC Voltage (V _d)			5.0		V
DC Current (I _d) ⁽⁶⁾		47	60	80	mA
DC Current (I _{Rbias})			2.4		mA
Noise Figure	0.05		1.8	—	dB
	0.5		0.8	—	
	1.0		0.8	—	
	2.0		1.0	1.3	
	3.0		1.3	—	
	4.0		1.6	—	
	5.0		1.9	—	
6.0		2.4	—		
Additive Phase Noise, 2.0 GHz, 10KHz offset			-160.5		dBc/Hz
Gain	0.05	—	26.0	—	dB
	0.5	—	23.2	—	
	1.0	—	19.4	—	
	2.0	12.7	14.4	15.8	
	3.0	—	11.1	—	
	4.0	—	9.2	—	
	5.0	—	7.3	—	
6.0	—	5.8	—		
Input Return Loss	0.05-0.5		10.0		dB
	0.5-6		7.0		
Output Return Loss	0.05-0.1		15.0		dB
	0.1-6		20.0		
Output IP3	0.05		31.8		dBm
	0.5		33.0		
	1.0		34.0		
	2.0		36.0		
	3.0		36.4		
	4.0		36.4		
	5.0		37.2		
6.0		37.2			
Output Power @ 1 dB compression ⁽²⁾	0.05		22.0		dBm
	0.5		21.7		
	1.0		21.7		
	2.0		21.6		
	3.0		21.5		
	4.0		21.7		
	5.0		22.0		
6.0		22.1			
DC Current Variation vs. Temperature ⁽³⁾			-0.072		mA/°C
Thermal Resistance			128		°C/W

MAXIMUM RATINGS⁽⁴⁾

Parameter	Ratings
Operating Temperature ⁽⁵⁾	-40°C to 85°C
Storage Temperature	-55°C to 100°C
Channel Temperature	150°C
DC Voltage (Pad 6)	6V
Power Dissipation	500mW
DC Current (Pad 6)	100mA
Bias Current (Pad 7)	10mA
Input Power ⁽⁷⁾	20dBm

(1) Measured on Mini-Circuits Characterization test board TB-502+. See Characterization Test Circuit (Fig. 1)

(2) P1dB specified with external current limiting of 70mA;

(3) (Current at 85°C - Current at -45°C)/130

(4) Permanent damage may occur if any of these limits are exceeded.

These maximum ratings are not intended for continuous normal operation.

(5) Defined with reference to ground pad temperature.

(6) Specified DC current consumption is under small signal conditions. Current will increase with input RF Power. To maintain maximum current consumption, external DC current limiting circuits are required on Vd line.

(7) Maximum input power is specified based upon external Vd current limiting of 80 mA. Maximum input power will degrade without external current limiting.

(4) Permanent damage may occur if any of these limits are exceeded. Electrical maximum ratings are not intended for continuous normal operation.

(5) Measured on Mini-Circuits test board, TB-736+





LOW NOISE, HIGH IP3

Monolithic Amplifier

PMA-5456+

SIMPLIFIED SCHEMATIC AND PAD DESCRIPTION

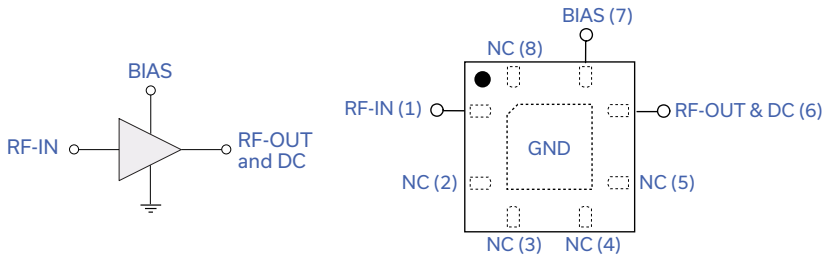

Function	Pad Number	Description (See Application Circuit, Fig. 3)
RF-IN	1	RF input pad
RF-OUT & DC	6	RF output pad (connected to RF-OUT via blocking external cap C2, and Supply voltage Vs via RF Choke L1)
BIAS	7	Bias pad (connected to Vs via Rbias)
GND	paddle in center of bottom	Connected to ground
NOT USED	2,3,4,5,8	No internal connection; recommended use: per PCB Layout PL-299

CHARACTERIZATION TEST CIRCUIT

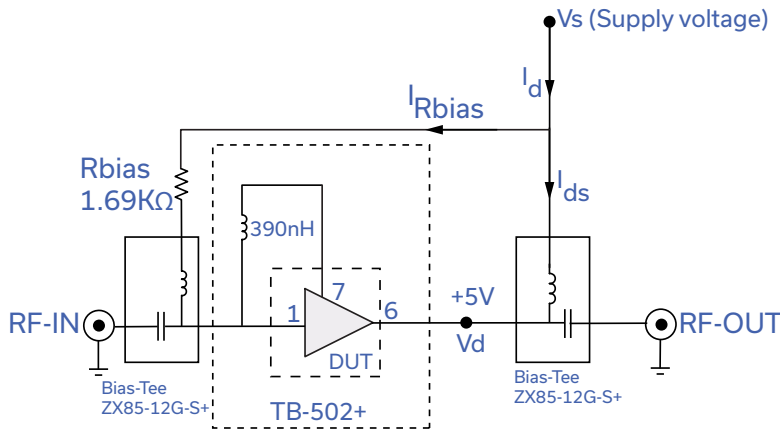

Fig 1. Block Diagram of Test Circuit used for characterization. (DUT soldered on Mini-Circuits Characterization Test Board TB-502+) Gain, Output power at 1dB compression (P1dB), Output IP3 (OIP3) and Noise Figure measured using Agilent's N5242A PNA-X Microwave network analyzer.

Conditions:

1. Gain: Pin=-25 dBm
2. Output IP3 (OIP3): Two tones, spaced 1 MHz apart, 5 dBm/tone at output.
3. Vs adjusted for 5V at device (Vd), compensating loss of bias tee.

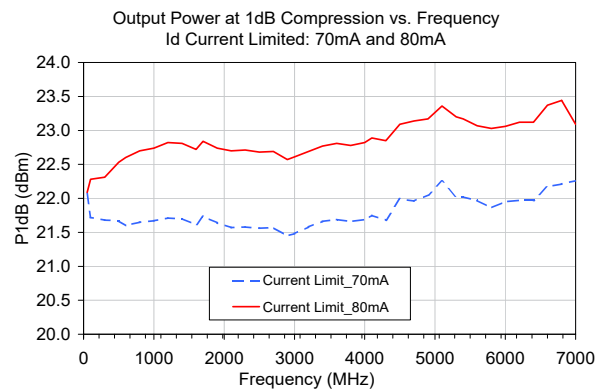
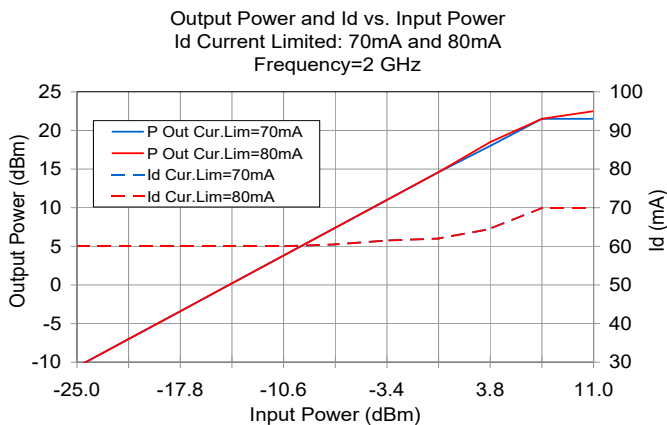

Fig 2. Output Power and Id vs. Input Power and Frequency. Performance measured on Mini-Circuits Characterization test board TB-502+. See Characterization Test Circuit (Fig. 1) Measurements performed with current (Id) limited as noted.





LOW NOISE, HIGH IP3

Monolithic Amplifier

PMA-5456+

RECOMMENDED APPLICATION CIRCUIT

(refer to evaluation board for PCB Layout and component values)

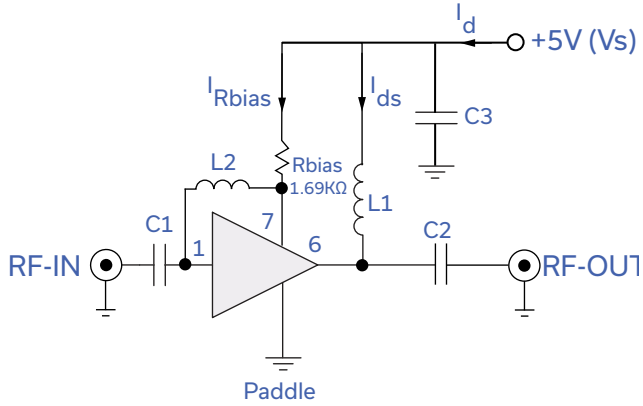

Fig 3. Recommended Application Circuit
Note: Resistance of L1, 0.1-0.2Ω typically

PRODUCT MARKING



- ← black body
- ← index over pin 1
- ← model family designation

Marking may contain other features or characters for internal lot control



LOW NOISE, HIGH IP3

Monolithic Amplifier

PMA-5456+

ADDITIONAL DETAILED TECHNICAL INFORMATION IS AVAILABLE ON OUR DASH BOARD. TO ACCESS [CLICK HERE](#)

Performance Data	Data Table graphs, s-parameter data set (.zip file)
Case Style	DQ849 Plastic package, exposed paddle, lead finish: tin-silver over nickel
Tape & Reel Standard quantities available on reel	F104 7" reels with 20, 50, 100, 200, 500, 1K, or 2K devices.
Suggested Layout for PCB Design	PL-299
Evaluation Board	TB-501-6+ (50-5000 MHz)
Environmental Ratings	ENV08T1

ESD RATING

Human Body Model (HBM): Class 1A (250V to <500V) in accordance with ANSI/ESD STM 5.1 - 2001

Machine Model (MM): Class M1 (<100V) in accordance with ANSI/ESD STM5.2-1999; passes 40V

MSL RATING

Moisture Sensitivity: MSL1 in accordance with IPC/JEDEC J-STD-020D

MSL TEST FLOW CHART

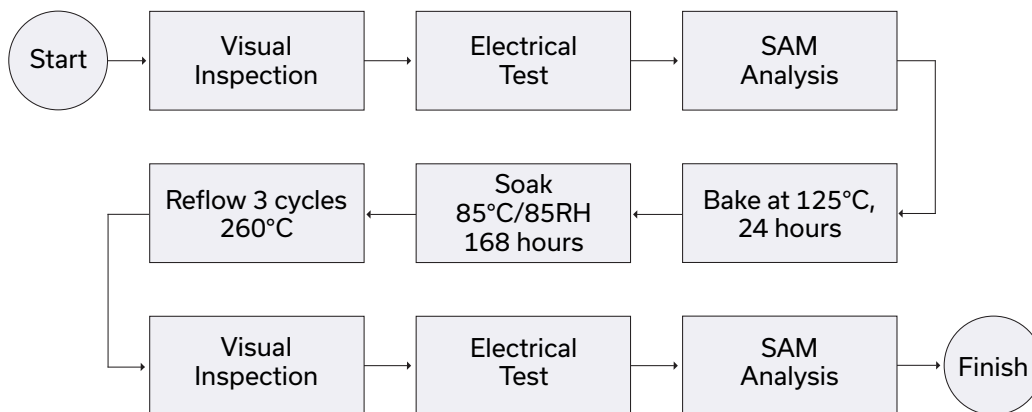

NOTES

- A. Performance and quality attributes and conditions not expressly stated in this specification document are intended to be excluded and do not form a part of this specification document.
- B. Electrical specifications and performance data contained in this specification document are based on Mini-Circuit's applicable established test performance criteria and measurement instructions.
- C. The parts covered by this specification document are subject to Mini-Circuits standard limited warranty and terms and conditions (collectively, "Standard Terms"); Purchasers of this part are entitled to the rights and benefits contained therein. For a full statement of the standard. Terms and the exclusive rights and remedies thereunder, please visit Mini-Circuits' website at www.minicircuits.com/MCLStore/terms.jsp



Looking for pricing, stock, or lifecycle information?

Click below to explore more details on WIN SOURCE:

 [View PMA-5456+](#) on WIN SOURCE

 [Mini-Circuits](#) Information

Optimize Your Supply Chain with WIN SOURCE Solutions

-  Global Sourcing Solution
-  Obsolete Management
-  Cost Control Management
-  Shortage Management
-  Alternative Solution
-  Excess Inventory Management