

Surface Mount

Dual Matched MMIC Amplifier

MGVA-63+

50Ω 0.04 to 3 GHz

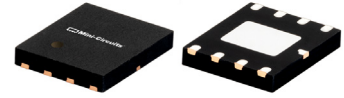

CASE STYLE: DL1020

The Big Deal

- High Gain, 21.4 dB
- Dual matched amplifier for push-pull & balanced amplifiers
- High dynamic range

Product Overview

MGVA-63+ is a dual matched wideband amplifier fabricated using advanced InGaP HBT technology, offering high dynamic range (High IP3 and Low NF) for use in 50 and 75 ohm applications. This model has demonstrated high IP2 in wideband amplifier evaluation boards. Combining this performance with low noise figure makes it suitable for use in very high dynamic range amplifiers.

Key Features

Feature	Advantages
Broadband	Covers many communication bands including cellular, cable TV, PCS, SATCOM, WiMAX, and more.
Matched pair for use in high IP3 and IP2 amplifiers	Typical gain match of 0.2 dB and phase match of 1.5°, enables it to be used in push-pull amplifiers. Outstanding IP2.
High IP2, 68.4 dBm at 0.9 GHz (Push-Pull amplifier)	Excellent suppression of unwanted second harmonics in wide band applications
High IP3, up to 34 dBm	Ideal for suppressing unwanted intermods in the presence of multiple carriers, now common in many communication systems.
High P1dB: Up to 19.4 dBm	High P1dB enables the amplifier to operate in linear region in the presence of strong interfering signals.
Medium Noise Figure: 3.5-3.7 dB typical	Together with High OIP3/P1dB, results in high dynamic range



Surface Mount

Dual Matched MMIC Amplifier

0.04-3GHz

Product Features

- Two matched amplifiers in one package
- High IP3, +34.3 dBm at 0.9 GHz
- High IP2, +70 dBm at 0.9 GHz in push-pull configuration
- Gain, 21.4 dB typ at 0.9 GHz
- P1dB, +19.4 dBm typ at 0.9 GHz

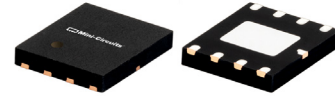

Generic photo used for illustration purposes only

MGVA-63+

CASE STYLE: DL1020

+RoHS Compliant

The +Suffix identifies RoHS Compliance. See our web site for RoHS Compliance methodologies and qualifications

Typical Applications

- SATCOM
- CATV
- FTTH
- Optical networks
- Base station infrastructure
- Balanced amplifiers
- 75 Ohm push-pull and balanced amplifiers

General Description

MGVA-63+ (RoHS compliant) is a high gain amplifier fabricated using InGaP HBT technology and offers high dynamic range over a broad frequency range. Lead finish is SnAgNi and is enclosed in a 4.9 x 6 mm MCLP package for good thermal performance.

simplified schematic (each of A1, A2) and pad description

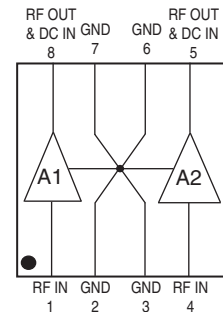
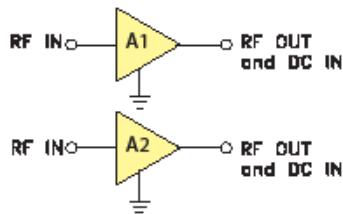

Function	Pad Number	Description
RF IN, A1	1	RF input pin. This pin requires the use of an external DC blocking capacitor chosen for the frequency of operation. (see Application circuit, Fig 2.)
RF-OUT and DC-IN, A1	8	RF output and bias pin. DC voltage is present on this pin; therefore a DC blocking capacitor is necessary for proper operation. An RF choke is needed to feed DC bias without loss of RF signal due to the bias connection, as shown in "Recommended Application Circuit", Fig 2
RF IN, A2	4	RF input pin. This pin requires the use of an external DC blocking capacitor chosen for the frequency of operation. (see Application circuit, Fig 2.)
RF-OUT and DC-IN, A2	5	RF output and bias pin. DC voltage is present on this pin; therefore a DC blocking capacitor is necessary for proper operation. An RF choke is needed to feed DC bias without loss of RF signal due to the bias connection, as shown in "Recommended Application Circuit", Fig 2
GND	2,3,6,7 & paddle	Connections to ground. Use via holes as shown in "Suggested Layout for PCB Design" to reduce ground path inductance for best performance.

* Enhancement mode pseudomorphic High Electron Mobility Transistor.



Electrical Specifications¹ at 25°C, Zo=50Ω and Device Voltage 5V, unless noted
(Specifications (other than Matching or where defined as push-pull) are for each of the two matched amplifiers in the package)

Parameter	Condition (GHz)	Min.	Typ.	Max.	Units	
Frequency Range		0.04		3.0	GHz	
Gain	0.04	—	22.2	—	dB	
	0.5	—	21.4	—		
	0.9	19.2	21.4	23.5		
	2.0	—	20.8	—		
	2.6	—	19.8	—		
	3.0	—	18.9	—		
Gain Flatness	0.05-3.0		±1.5		dB	
Input Return Loss	0.04		16.3		dB	
	0.5		18.1			
	0.9		16.6			
	2.0		11.8			
	2.6		9.2			
	3.0		7.7			
Output Return Loss	0.04		13.5		dB	
	0.5		20.5			
	0.9		17.2			
	2.0		8.5			
	2.6		6.3			
	3.0		5.2			
Output Power @ 1 dB compression ^(2,3)	0.04		19.3		dBm	
	0.5		19.0			
	0.9		19.4			
	2.0		19.0			
	2.6		18.0			
	3.0		17.4			
Output IP3 ⁽³⁾	0.04	—	33.6	—	dBm	
	0.5	—	34.3	—		
	0.9	31.0	34.3	—		
	2.0	—	32.2	—		
	2.6	—	30.7	—		
	3.0	—	29.6	—		
Noise Figure	0.04		3.6		dB	
	0.5		3.6			
	0.9		3.6			
	2.0		3.6			
	2.6		3.8			
	3.0		3.7			
Matching between A1, A2	Amplitude Unbalance	0.04	—	0.1	—	dB
		0.5	—	0.1	—	
		0.9	—	0.1	0.5	
		2.0	—	0.2	—	
		2.6	—	0.2	—	
		3.0	—	0.1	—	
	Phase Unbalance	0.04	—	0.0	—	deg.
		0.5	—	0.6	—	
		0.9	—	0.9	5.0	
		2.0	—	1.5	—	
2.6		—	1.5	—		
	3.0	—	0.6	—		
Device Operating Voltage		4.8	5.0	5.2	V	
Device Operating Current (each amplifier)			69	78	mA	
Device Current Variation vs. Temperature			69		μA/°C	
Device Current Variation vs Voltage			0.043		mA/mV	
Thermal Resistance, junction-to-ground lead ⁽⁴⁾			58.4		°C/W	

⁽¹⁾ Measured on Mini-Circuits Test Board TB-561-63+, see characterization circuit, Fig 1.
⁽²⁾ Current increases at P1dB

⁽³⁾ Per single ended amplifier
⁽⁴⁾ $\theta_{jc} = (\text{Junction Temperature} - 85^\circ\text{C}) / (\text{Voltage} \times \text{sum of current in A1 \& A2})$

Absolute Maximum Ratings for each Amplifier⁽⁶⁾

Parameter	Ratings
Operating Temperature ⁷	-40°C to 85°C
Storage Temperature	-55°C to 150°C
Operating Current at 5V	100 mA
Power Dissipation	0.5 W
Input Power (CW)	13 dBm
DC Voltage (pads 5, 8)	5.7

⁽⁶⁾ Permanent damage may occur if any of these limits are exceeded.
 These ratings are not intended for continuous normal operation.
⁽⁷⁾ Defined with reference to ground pad temperature.

Push-Pull Amplifier Typical Performance ⁽⁵⁾

Freq. (GHz)	TB-666-50-63+ (50Ω)		
	Gain (dB)	Output IP3 (dBm)	Output IP2 (dBm)
0.04	18.5	32.2	58.1
0.5	19.1	32.1	64.1
0.9	18.9	35.9	68.4
2.0	18.2	32.7	49.5
2.6	17.1	30.7	67.9
3.0	16.4	30.2	67.6

⁽⁵⁾ Measured on evaluation boards TB-666-50-63+ (push-pull amplifier)



Characterization Test Circuit

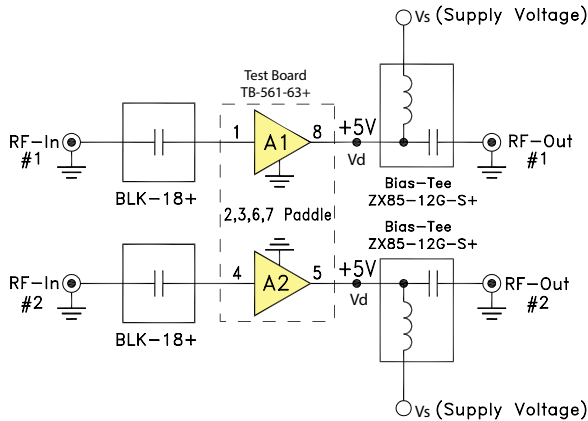

Fig 1a. Block Diagram of Test Circuit used for characterization. (DUT tested in Mini-Circuits Test board TB-561-63+, except for IP2). Gain, Return loss, Output Power at 1dB compression (P1 dB) , output IP3 (OIP3) and noise figure measured using Agilent’s N5242A PNA-X micro-wave network analyzer.

Conditions:

1. Gain and Return loss: Pin= -25dBm
2. Output IP3 (OIP3): Two tones, spaced 1MHz apart, 0 dBm/tone at output.



Mini-Circuits Evaluation Boards, 50Ω Push-Pull Amplifiers TB-666-50-63+ (MGVA-63+ inside)

Fig 1b. Block Diagram of Test Set up used for characterization of Gain, IP2, IP3 of push-pull amplifier. Measured using Agilent’s signal generators E8527D and Spectrum analyzer N9020A.

Conditions:

1. Gain and Return loss: Pin= -25dBm
2. Output IP3 & IP2: Two tones, spaced 1MHz apart, 8 dBm/tone at output. IP2 is measured at the sum frequency of the tones.

Recommended Application Circuit

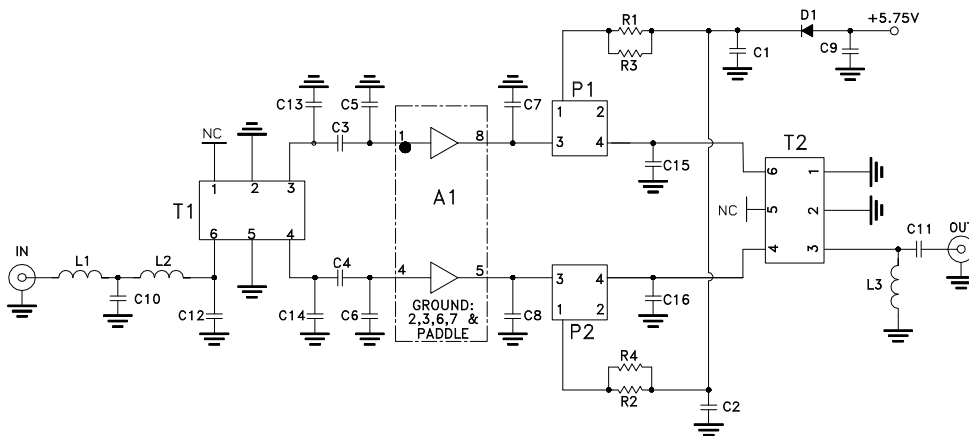

COMPONENT	VALUE	SIZE
A1	Mini-Circuits MGVA-63+	PER DATA SHEET
C1,C2	.039 uF	0805
C3,C4	.001 uF	0402
C5,C6	.2 pF	0402
C7,C8	1.1 pF	0402
C9	1.0 uF	1311
C10	.4 pF	0603
C11	270 pF	0805
C12	.4 pF	0402
C13	.7 pF	0402
C14	.3 pF	0402
C15	.6 pF	0402
C16	1.0 pF	0402
D1	Diode, Schottky Rectifier Vf=.385V @ .5A, Vr=10V MAX	-
L1,L2	1.1 nH	.073"X.054"
L3	1.5 uH	1008
R1,R2	5.11 Ohm	1206
R3,R4	7.50 Ohm	1206
T1	Mini-Circuits TCM2-33WX+	PER DATA SHEET
T2	Mini-Circuits TCM2-43X+	PER DATA SHEET
P1,P2	Mini-Circuits TCBT-6G+	PER DATA SHEET

Fig 2. Recommended Application Circuit. Mini-Circuits Evaluation Board 50Ω: TB-666-50-63+

Product Marking

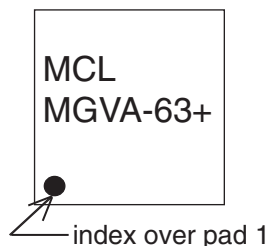

Additional Detailed Technical Information <i>additional information is available on our dash board. To access this information click here</i>	
Performance Data	Data Table
	Swept Graphs
	S-Parameter (S4P Files) Data Set (.zip file)
Case Style	DL1020 <i>Plastic package, exposed paddle lead finish: tin-silver over nickel</i>
Tape & Reel Standard quantities available on reel	F68 <i>7" reels with 20, 50, 100, 200, 500 or 1K devices 13" reels with 2K, 3K, 4K devices</i>
Suggested Layout for PCB Design	PL-322
Evaluation Board	TB-666-50-63+ (50Ω)
Environmental Ratings	ENV08T2

ESD Rating

Human Body Model (HBM): Class 1C (1000 to <2000V) in accordance with ANSI/ESD STM 5.1 - 2001
Machine Model (MM): Class M2 (100 to <200V) in accordance with ANSI/ESD STM5.2-1999

MSL Rating

Moisture Sensitivity: MSL1 in accordance with IPC/JEDEC J-STD-020D

MSL Test Flow Chart

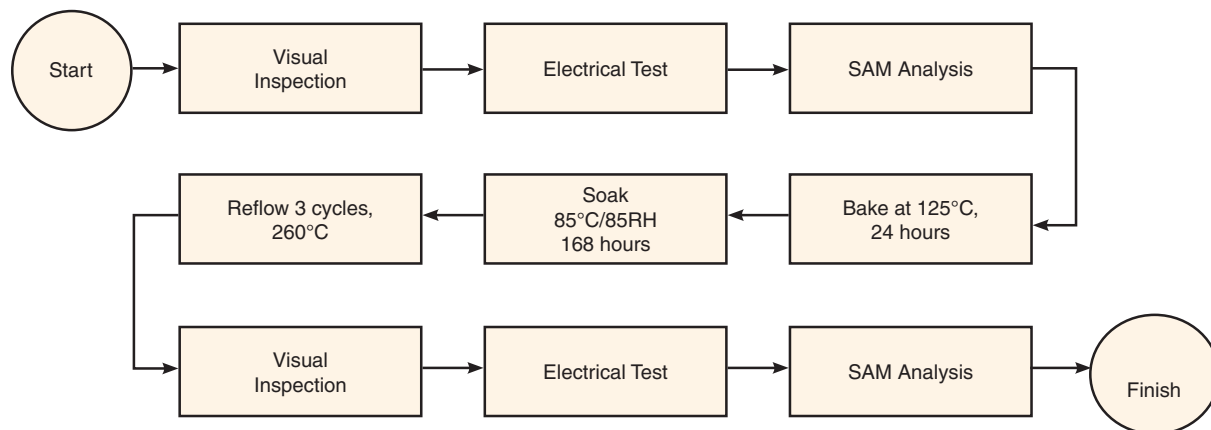

Additional Notes

- A. Performance and quality attributes and conditions not expressly stated in this specification document are intended to be excluded and do not form a part of this specification document.
- B. Electrical specifications and performance data contained in this specification document are based on Mini-Circuit's applicable established test performance criteria and measurement instructions.
- C. The parts covered by this specification document are subject to Mini-Circuits standard limited warranty and terms and conditions (collectively, "Standard Terms"); Purchasers of this part are entitled to the rights and benefits contained therein. For a full statement of the Standard Terms and the exclusive rights and remedies thereunder, please visit Mini-Circuits' website at www.minicircuits.com/MCLStore/terms.jsp

Looking for pricing, stock, or lifecycle information?

Click below to explore more details on WIN SOURCE:

 [View MGVA-63+ on WIN SOURCE](#)

 [Mini-Circuits Information](#)

Optimize Your Supply Chain with WIN SOURCE Solutions

-  Global Sourcing Solution
-  Obsolete Management
-  Cost Control Management
-  Shortage Management
-  Alternative Solution
-  Excess Inventory Management