



THE DATASHEET OF MNA-2A+





HIGH DIRECTIVITY

Monolithic Amplifier

MNA-2A+

50Ω 0.5 to 2.5 GHz

THE BIG DEAL

- Integrated matching, DC Blocks and bias circuits
- Excellent Active Directivity, +22 dB typ. at 2 GHz and 5V
- Choice of supply voltage, +2.8V to +5V
- Micro-miniature size .120"X.120"
- Output power, +17.9 dBm typ. at 2 GHz and 5V
- Aqueous washable

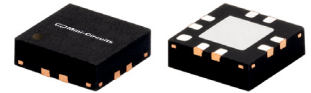

Generic photo used for illustration purposes only

CASE STYLE: DQ849

+RoHS Compliant

The +Suffix identifies RoHS Compliance. See our website for methodologies and qualifications

APPLICATIONS

- Buffer amplifier
- Cellular infrastructure
- Communications satellite
- Defense

PRODUCT OVERVIEW

MNA-2A+ is a wideband PHEMT based MMIC amplifier with high active Directivity. MNA integrates the entire matching network and majority of the bias circuit inside the package, reducing the need for complicated external circuits. This approach makes the MNA amplifier extremely straightforward to use. This design operates on a single 2.8 to 5V supply, is well matched for 50Ω and comes in a tiny, low profile 3x3mm 8-lead MCLP package accommodating dense circuit board layouts. [MNA-2A+ belongs to MNA series of models available in Die and packaged form.](#)

KEY FEATURES

Feature	Advantages
Excellent Active Directivity (Isolation- Gain) 21-36 dB	Ideal for use as a buffer amplifier minimizing interaction of adjacent circuits
Integrates DC blocks and RF choke	Minimizes external components, component count and circuit area.
Single +2.8 to +5V operation	Amplifier can be used at low voltage such as +3V or standard +5V. +5V operation results in higher P1dB and OIP3.
3 x 3mm 8-lead MCLP package	Tiny footprint saves space in dense layouts while providing low inductance, repeatable transitions, and excellent thermal contact to the PCB.

REV. A
ECO-011187
MNA-2A+
MCL NY
220928





HIGH DIRECTIVITY

Monolithic Amplifier

MNA-2A+

Mini-Circuits

ELECTRICAL SPECIFICATIONS¹ AT 25°C

Parameter	Condition (GHz)	Vs=5V			Vs=2.8V	Units
		Min.	Typ.	Max.	Typ.	
Frequency Range		0.5		2.5	0.5-2.5	GHz
Gain	0.5	—	14.1	—	12.4	dB
	0.75	—	14.8	—	12.9	
	1.0	—	15.0	—	13.0	
	1.5	—	15.2	—	13.0	
	2.0	13.5	15.0	16.5	12.6	
	2.5	—	14.7	—	12.3	
Input Return Loss	0.5		8		8	dB
	0.75		13		13	
	1.0		16		17	
	1.5		20		23	
	2.0		19		22	
	2.5		17		19	
Output Return Loss	0.5		14		13	dB
	0.75		21		17	
	1.0		21		18	
	1.5		18		18	
	2.0		15		18	
	2.5		14		17	
Output Power at P1dB	0.5		19.2		10.3	dBm
	0.75		19.3		11.1	
	1.0		19.1		11.4	
	1.5		18.6		11.5	
	2.0		17.9		11.8	
	2.5		17.5		11.8	
Output IP3	0.5		32		22	dBm
	0.75		32		23	
	1.0		31		23	
	1.5		31		23	
	2.0		29		23	
	2.5		29		23	
Noise Figure (dB)	0.5		5.6		5.8	dB
	0.75		5.5		5.6	
	1.0		5.3		5.4	
	1.5		5.4		5.5	
	2.0		5.3		5.5	
	2.5		5.4		5.6	
Active Directivity (Isolation-Gain)	0.5		33		36	dB
	0.75		33		32	
	1.0		29		28	
	1.5		24		24	
	2.0		22		22	
	2.5		21		21	
DC Current			84	104	79	mA
Device Current Variation vs. Temperature ⁽²⁾			32		15	μA/°C
Device Current Variation vs Voltage			0.001 ⁽³⁾		0.003 ⁽⁴⁾	mA/mV
Thermal resistance at 85°C (Junction to Lead)			54		54	°C/W

(1) Measured on Mini-Circuits Characterization test board TB-186+. See Characterization Test Circuit (Fig. 1)

(2) (Current at 85°C - Current at -45°C)/130

(3) (Current at 5.25V - Current at 3.9V)/1.35

(4) (Current at 3.9V - Current at 2.66V)/1.24



HIGH DIRECTIVITY

Monolithic Amplifier

MNA-2A+

MAXIMUM RATINGS⁵

Parameter	Ratings
Operating Temperature	-40°C to 85°C
Storage Temperature	-55°C to 100°C
DC Voltage	7 V at pin 7 (on TB-186+) 1V at pins 2 & 5
Power Dissipation	800 mW
Input Power	+11 dBm at Vs=+2.8V and +16 dBm at +5V (continuous operation) +23 dBm (5 minutes max)

5. Permanent damage may occur if any of these limits are exceeded. These ratings are not intended for continuous normal operation.

SIMPLIFIED SCHEMATIC AND PAD DESCRIPTION

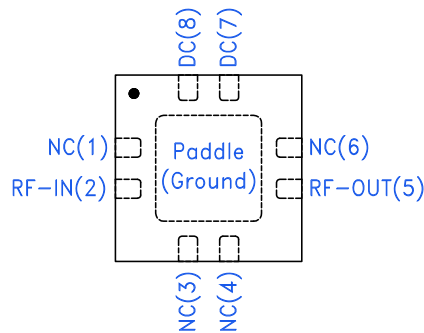
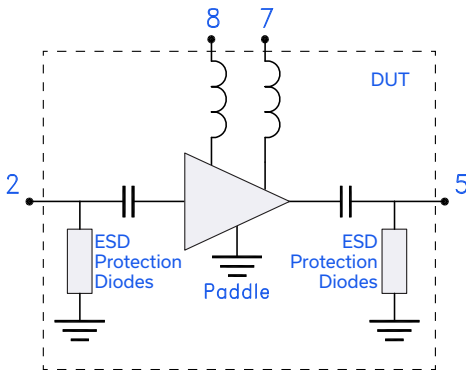

Function	Pad Number	Description (See Fig 1)
RF-IN	2	RF input pin
RF-OUT	5	RF output pin
DC	7,8	DC Bias pads 7,8. Pad 7 connected to ground via 1000 pF. Pad 8 connected to pad 7 via 33.2 ohms.
NC	1,3,4,6	Not Connected, connect pad 3 and 4 to ground externally
GND	Paddle	Ground
OPTIONAL	1,6	No internal connection; recommended use: per PCB Layout PL-078



CHARACTERIZATION & APPLICATION TEST CIRCUIT

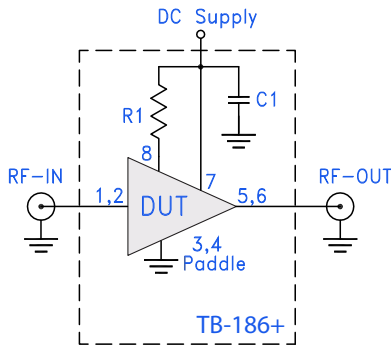

Fig 1. Block Diagram of Test Circuit used for characterization. (DUT soldered on Mini-Circuits Characterization test board TB-186+)

Gain, Return loss, Output power at 1dB compression (P1 dB) , output IP3 (OIP3) and noise figure measured using Agilent's N5242A PNA-X microwave network analyzer.

Conditions:

1. Gain and Return loss: Pin= -25dBm
2. Output IP3 (OIP3): Two tones, spaced 1 MHz apart, 0 dBm/tone at output.

Component	Size	Value	Units
R1	0805	33.2	Ω
C1	0402	1000	ρ F

RECOMMENDED APPLICATION CIRCUIT

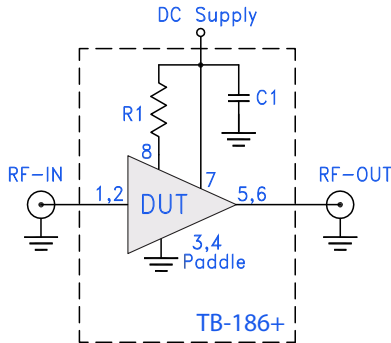

Fig 2. Test Board includes case, connectors, and components soldered to PCB

Component	Size	Value	Units
R1	0805	33.2	Ω
C1	0402	1000	ρ F

PRODUCT MARKING



Marking may contain other features or characters for internal lot control



HIGH DIRECTIVITY

Monolithic Amplifier

MNA-2A+

ADDITIONAL DETAILED TECHNICAL INFORMATION IS AVAILABLE ON OUR DASH BOARD. TO ACCESS [CLICK HERE](#)

Performance Data	Data Table Swept Graphs S-Parameter (S2P Files) Data Set (.zip file)
Case Style	DQ849 3x3x0.9 mm MCLP Plastic package, exposed paddle lead finish: Matte-Tin
Tape & Reel Standard quantities available on reel	F104 7" reels with 10, 20, 50, 100, 200, 500, 1000 or 2000 devices
Suggested Layout for PCB Design	PL-078
Evaluation Board	TB-186-2A+
Environmental Ratings	ENV08T1

ESD RATING

Human Body Model (HBM): Class 1A (250 to <500V) in accordance with ANSI/ESD STM 5.1 - 2001

MSL RATING

Moisture Sensitivity: MSL1 in accordance with IPC/JEDEC J-STD-020D

MSL TEST FLOW CHART

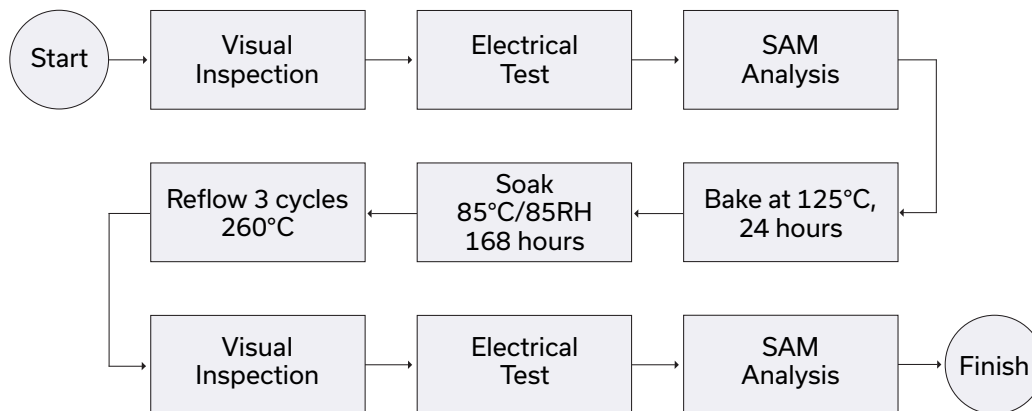



- NOTES**
- A. Performance and quality attributes and conditions not expressly stated in this specification document are intended to be excluded and do not form a part of this specification document.
 - B. Electrical specifications and performance data contained in this specification document are based on Mini-Circuit's applicable established test performance criteria and measurement instructions.
 - C. The parts covered by this specification document are subject to Mini-Circuits standard limited warranty and terms and conditions (collectively, "Standard Terms"); Purchasers of this part are entitled to the rights and benefits contained therein. For a full statement of the standard. Terms and the exclusive rights and remedies thereunder, please visit Mini-Circuits' website at www.minicircuits.com/MCLStore/terms.jsp



Looking for pricing, stock, or lifecycle information?

Click below to explore more details on WIN SOURCE:

-  [View MNA-2A+](#) on WIN SOURCE
-  [Mini-Circuits](#) Information

Optimize Your Supply Chain with WIN SOURCE Solutions

-  Global Sourcing Solution
-  Obsolete Management
-  Cost Control Management
-  Shortage Management
-  Alternative Solution
-  Excess Inventory Management