

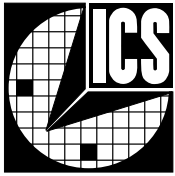

**THE DATASHEET OF
ICS9250BF-28**





Frequency Generator & Integrated Buffers for Celeron & PII/III™

Recommended Application:

810/810E and 815 type chipset.

Output Features:

- 2 CPU (2.5V) (up to 133MHz achievable through I²C)
- 13 SDRAM (3.3V) (up to 133MHz achievable through I²C)
- 2 PCI (3.3 V) @33.3MHz
- 1 IOAPIC (2.5V) @ 33.3 MHz
- 3 Hublink clocks (3.3 V) @ 66.6 MHz
- 2 (3.3V) @ 48 MHz (Non spread spectrum)
- 1 REF (3.3V) @ 14.318 MHz

Features:

- Supports spread spectrum modulation, 0 to -0.5% down spread.
- I²C support for power management
- Efficient power management scheme through PD#
- Uses external 14.138 MHz crystal
- Alternate frequency selections available through I²C control.

Pin Configuration

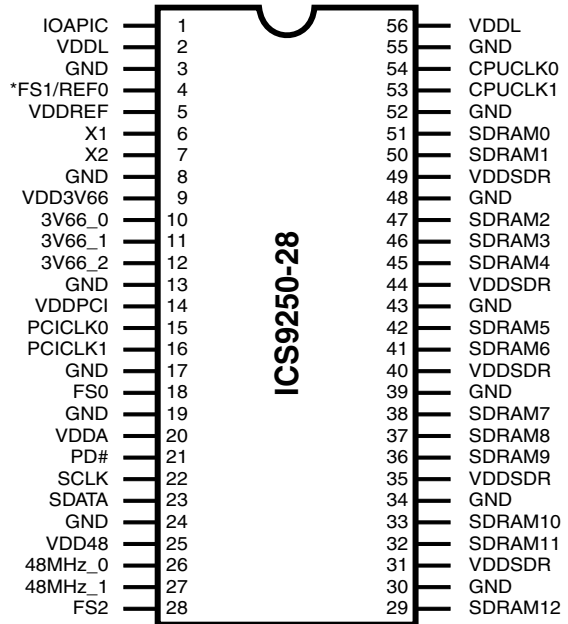

56-Pin 300mil SSOP

* This input has a 50KΩ pull-down to GND.

Block Diagram

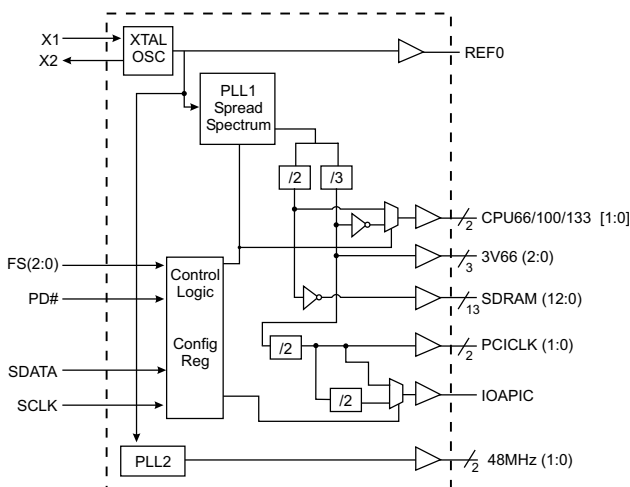

Functionality

FS2	FS0	FS1	Function
0	0	X	Tristate
0	1	X	Test
1	0	0	Active CPU = 66MHz SDRAM = 100MHz
1	1	0	Active CPU = 100MHz SDRAM = 100MHz
1	0	1	Active CPU = 133MHz SDRAM = 133MHz
1	1	1	Active CPU = 133MHz SDRAM = 100MHz

Power Groups

Analog
VDDREF = X1, X2
VDDA = PLL1
VDD48 = PLL2

Digital
VDD3V66, VDDPCI
VDDSDR, VDDL

ICS9250-28



General Description

The **ICS9250-28** is part of a two chip clock solution for 810/810E and 815 type chipset. Combined with the ICS9112-17, the **ICS9250-28** provides all necessary clock signals for such a system.

Spread spectrum may be enabled through I²C programming. Spread spectrum typically reduces EMI by 8dB to 10 dB. This simplifies EMI qualification without resorting to board design iterations or costly shielding. The ICS9250-28 employs a proprietary closed loop design, which tightly controls the percentage of spreading over process and temperature variations.

Pin Configuration

PIN NUMBER	PIN NAME	TYPE	DESCRIPTION
1	IOAPIC	OUT	2.5V clock output running at 33.3MHz.
2, 56	VDDL	PWR	2.5V power supply for CPU & IOAPIC
4	FS1	IN	Function Select pin. Determines CPU frequency, all output functionality
	REF0	OUT	3.3V, 14.318MHz reference clock output.
5, 9, 14, 20, 25, 31, 35, 40, 44, 49	VDD	PWR	3.3V power supply
6	X1	IN	Crystal input, has internal load cap (33pF) and feedback resistor from X2
7	X2	OUT	Crystal output, nominally 14.318MHz. Has internal load cap (33pF)
3, 8, 13, 17, 19, 24, 30, 34, 39, 43, 48, 52, 55	GND	PWR	Ground pins for 3.3V supply
12, 11, 10	3V66 (2:0)	OUT	3.3V Fixed 66MHz clock outputs for HUB
28, 18	FS (2, 0)	IN	Function Select pins. Determines CPU frequency, all output functionality. Please refer to Functionality table on page 3.
16, 15	PCICLK[1:0]	OUT	3.3V PCI clock outputs
21	PD#	IN	Asynchronous active low input pin used to power down the device into a low power state. The internal clocks are disabled and the VCO and the crystal are stopped. The latency of the power down will not be greater than 3ms.
22	SCLK	IN	Clock pin of I ² C circuitry 5V tolerant
23	SDATA	I/O	Data pin for I ² C circuitry 5V tolerant
26, 27	48MHz_0	OUT	3.3V Fixed 48MHz clock outputs.
29, 32, 33, 36, 37, 38, 41, 42, 45, 46, 47, 50, 51	SDRAM (12:0)	OUT	3.3V output running 100MHz. All SDRAM outputs can be turned off through I ² C
54, 53	CPUCLK (1:0)	OUT	2.5V Host bus clock output. 66MHz, 100MHz or 133MHz depending on FS (2:0) pins.



Power Down Waveform

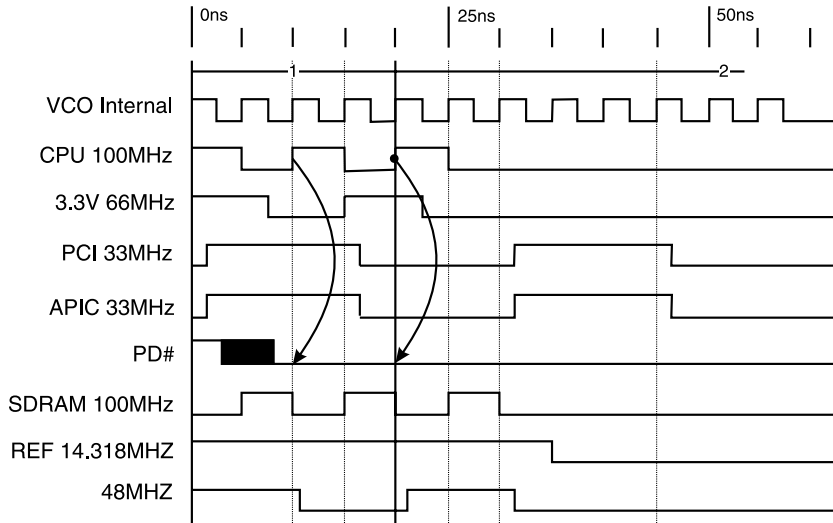

Note

1. After PD# is sampled active (Low) for 2 consecutive rising edges of CPUCLKs, all the output clocks are driven Low on their next High to Low transition.
2. Power-up latency <3ms.
3. Waveform shown for 100MHz

Maximum Allowed Current

815 Condition	Max 2.5V supply consumption Max discrete cap loads, Vddq2 = 2.625V All static inputs = Vddq3 or GND	Max 2.5V supply consumption Max discrete cap loads, Vddq2 = 3.465V All static inputs = Vddq3 or GND
Powerdown Mode (PWRDWN# = 0)	10mA	10mA
Full Active 66MHz FS[2:0] = 010	70mA	400mA
Full Active 100MHz FS[2:0] = 011	100mA	400mA
Full Active 133MHz FS[2:0] = 111	130mA	450mA

Clock Enable Configuration

PD#	CPUCLK	SDRAM	IOAPIC	66MHz	PCICLK	REF, 48MHz	Osc	VCOs
0	LOW	LOW	LOW	LOW	LOW	LOW	OFF	OFF
1	ON	ON	ON	ON	ON	ON	ON	ON



Truth Table

FS2	FS0	FS1	CPU	SDRAM	3V66	PCI	48MHz	REF	IOAPIC
0	0	X	Tristate	Tristate	Tristate	Tristate	Tristate	Tristate	Tristate
0	1	X	TCLK/2	TCLK/2	TCLK/3	TCLK/6	TCLK/2	TCLK	TCLK/6
1	0	0	66.6 MHz	100 MHz	66.6 MHz	33.3 MHz	48 MHz	14.318 MHz	33.3 MHz
1	1	0	100 MHz	100 MHz	66.6 MHz	33.3 MHz	48 MHz	14.318 MHz	33.3 MHz
1	0	1	133 MHz	133 MHz	66.6 MHz	33.3 MHz	48 MHz	14.318 MHz	33.3 MHz
1	1	1	133 MHz	100 MHz	66.6 MHz	33.3 MHz	48 MHz	14.318 MHz	33.3 MHz

Byte 3: ICS Reserved Functionality and frequency select register (Default as noted in PWD)

Bit	Description								PWD
Bit7	ICS Reserved bit (Note 2)								0
Bit6	ICS Reserved bit (Note 2)								0
Bit5	ICS Reserved bit (Note 2)								0
Bit4	ICS Reserved bit (Note 2)								0
Bit3	ICS Reserved bit (Note 2)								0
Bit2	Undefined bit (Note 3)								X
Bit1	Undefined bit (Note 3)								X
Bit 0	Bit 0	FS0	FS1	CPUCLK MHz	SDRAM MHz	3V66 MHz	PCICLK MHz	IOAPIC MHz	0 Note 1
	0	0	0	66.66	100.0	66.66	33.33	33.33	
	0	1	0	100.0	100.0	66.66	33.33	33.33	
	0	0	1	133.32	133.32	66.66	33.33	33.33	
	0	1	1	133.32	100.0	66.66	33.33	33.33	
	1	0	0	66.66	100.0	66.66	33.33	33.33	
	1	1	0	100.0	100.0	66.66	33.33	33.33	
	1	0	1	133.32	133.32	66.66	33.33	33.33	
1	1	1	133.32	133.32	66.66	33.33	33.33		

Note 1: For system operation, the BSEL lines of the CPU will program FS0, FS2 for the appropriate CPU speed, always with SDRAM = 100MHz. After BIOS verifies the SDRAM is PC133 speed, then bit 0 can be written from the default 0 to 1 to change the SDRAM output frequency from 100MHz to 133MHz. This will only change if the CPU is at the 133MHz FSB speed as shown in this table. The CPU, 3V66, PCI, and IOAPIC clocks will be glitch free during this transition, and only SDRAM will change.

Note 2: "ICS RESERVED BITS" must be written as "0".

Note 3: Undefined bits can be written either as "1 or 0"



Byte 0: Control Register
(1 = enable, 0 = disable)

Bit	Pin#	Name	PWD	Description
Bit 7	-	Reserved ID	0	(Active/Inactive)
Bit 6	-	Reserved ID	0	(Active/Inactive)
Bit 5	-	Reserved ID	0	(Active/Inactive)
Bit 4	-	Reserved ID	1	(Active/Inactive)
Bit 3	-	SpreadSpectrum (1=On/0=Off)	1	(Active/Inactive)
Bit 2	27	48MHz 1	1	(Active/Inactive)
Bit 1	26	48MHz 0	1	(Active/Inactive)
Bit 0	-	Reserved ID	0	(Active/Inactive)

Note: Reserved ID bits must be written as "0"

Byte 1: Control Register
(1 = enable, 0 = disable)

Bit	Pin#	Name	PWD	Description
Bit 7	38	SDRAM7	1	(Active/Inactive)
Bit 6	41	SDRAM6	1	(Active/Inactive)
Bit 5	42	SDRAM5	1	(Active/Inactive)
Bit 4	45	SDRAM4	1	(Active/Inactive)
Bit 3	46	SDRAM3	1	(Active/Inactive)
Bit 2	47	SDRAM2	1	(Active/Inactive)
Bit 1	50	SDRAM1	1	(Active/Inactive)
Bit 0	51	SDRAM0	1	(Active/Inactive)

Byte 2: Control Register
(1 = enable, 0 = disable)

Bit	Pin#	Name	PWD	Description
Bit 7	12	3V66-2 (AGP)	1	(Active/Inactive)
Bit 6	29	SDRAM12	1	(Active/Inactive)
Bit 5	32	SDRAM11	1	(Active/Inactive)
Bit 4	33	SDRAM10	1	(Active/Inactive)
Bit 3	36	SDRAM9	1	(Active/Inactive)
Bit 2	37	SDRAM8	1	(Active/Inactive)
Bit 1	16	PCICLK1	1	(Active/Inactive)
Bit 0	-	Reserved	0	(Active/Inactive)

Notes:

1. Inactive means outputs are held LOW and are disabled from switching. These outputs are designed to be configured at power-on and are not expected to be configured during the normal modes of operation.
2. PWD = Power on Default
3. Undefined bit can be written with either a "1" or "0".

ICS9250-28



Byte 4: Reserved Register (1 = enable, 0 = disable)

Bit	Pin#	Name	PWD	Description
Bit 7	-	Reserved	0	(Active/Inactive)
Bit 6	-	Reserved	0	(Active/Inactive)
Bit 5	-	Reserved	0	(Active/Inactive)
Bit 4	-	Reserved	0	(Active/Inactive)
Bit 3	-	Reserved	0	(Active/Inactive)
Bit 2	-	Reserved	0	(Active/Inactive)
Bit 1	-	Reserved	0	(Active/Inactive)
Bit 0	-	Reserved	0	(Active/Inactive)

Notes:

1. Inactive means outputs are held LOW and are disabled from switching. These outputs are designed to be configured at power-on and are not expected to be configured during the normal modes of operation.
2. PWD = Power on Default

Group Timing Relationship Table¹

Group	CPU 66MHz SDRAM 100MHz		CPU 100MHz SDRAM 100MHz		CPU 133MHz SDRAM 100MHz		CPU 133MHz SDRAM 133MHz	
	Offset	Tolerance	Offset	Tolerance	Offset	Tolerance	Offset	Tolerance
CPU to SDRAM	-2.5ns	500ps	5.0ns	500ps	0.0ns	500ps	3.75ns	500ps
CPU to 3V66	7.5ns	500ps	5.0ns	500ps	0.0ns	500ps	0.0ns	500ps
SDRAM to 3V66	0.0ns	500ps	0.0ns	500ps	0.0ns	500ps	-3.75ns	500ps
3V66 to PCI	1.5-3.5ns	500ps	1.5-3.5ns	500ps	1.5-3.5ns	500ps	1.5 -3.5ns	500ps
PCI to PCI	0.0ns	500ps	0.0ns	500ps	500ps	1.0ns	0.0ns	500ps
USB & DOT	Asynch	N/A	Asynch	N/A	Asynch	N/A	Asynch	N/A



Absolute Maximum Ratings

- Core Supply Voltage 4.6 V
- I/O Supply Voltage 3.6V
- Logic Inputs GND -0.5 V to V_{DD} +0.5 V
- Ambient Operating Temperature 0°C to +70°C
- Maximum Case Operating Temperature +135°C
- Storage Temperature -65°C to +150°C

Stresses above those listed under *Absolute Maximum Ratings* may cause permanent damage to the device. These ratings are stress specifications only and functional operation of the device at these or any other conditions above those listed in the operational sections of the specifications is not implied. Exposure to absolute maximum rating conditions for extended periods may affect product reliability.

Electrical Characteristics - Input/Supply/Common Output Parameters

T_A = 0 - 70C; Supply Voltage V_{DD} = 3.3 V +/-5%, V_{DDL} = 2.5 V +/-5% (unless otherwise stated)

PARAMETER	SYMBOL	CONDITIONS	MIN	TYP	MAX	UNITS	
Input High Voltage	V _{IH}		2		V _{DD} +0.3	V	
Input Low Voltage	V _{IL}		V _{SS} -0.3		0.8	V	
Input High Current	I _{IH}	V _{IN} = V _{DD}	-5		5	μA	
Input Low Current	I _{IL1}	V _{IN} = 0 V; Inputs with no pull-up resistors	-5			μA	
	I _{IL2}	V _{IN} = 0 V; Inputs with pull-up resistors	-200				
Operating Supply Current	I _{DD3.3OP}	C _L = 0 pF; @ 66/100 MHz		138	200	mA	
		C _L = 0 pF; @ 100/100 MHz		126	200		
		C _L = 0 pF; @ 133/133 MHz		172	200		
		C _L = 0 pF; @ 133/100 MHz		141	200		
		C _L = Max loads; @ 66/100 MHz		339	400	mA	
		C _L = Max loads; @ 100/100 MHz		328	400		
		C _L = Max loads; @ 133/133 MHz		383	450		
		C _L = Max loads; @ 133/100 MHz		340	400		
	I _{DD2.5OP}	C _L = 0 pF; @ 66/100 MHz			9	15	mA
		C _L = 0 pF; @ 100/100 MHz			11	18	
		C _L = 0 pF; @ 133/133 MHz			13	20	
		C _L = 0 pF; @ 133/100 MHz			13	20	
		C _L = Max loads; @ 66/100 MHz			13	35	mA
		C _L = Max loads; @ 100/100 MHz			23	60	
C _L = Max loads; @ 133/133 MHz				29	60		
C _L = Max loads; @ 133/100 MHz				30	60		
Powerdown Current	I _{DD3.3PD}	C _L = Max loads		251	400	μA	
	I _{DD.25PD}	Input address VDD or GND		<1	10		
Input Frequency	F _i	V _{DD} = 3.3 V	12	14.318	16	MHz	
Transition time ¹	T _{trans}	To 1st crossing of target frequency			3	ms	
Settling time ¹	T _s	From 1st crossing to 1% target frequency			3	ms	
Clk Stabilization ¹	T _{STAB}	From V _{DD} = 3.3 V to 1% target frequency			3	ms	
Delay ¹	t _{PZH} , t _{PZL}	Output enable delay (all outputs)	1		10	ns	
	t _{PHZ} , t _{PLZ}	Output disable delay (all outputs)	1		10	ns	

¹Guaranteed by design, not 100% tested in production.



Electrical Characteristics - CPU

$T_A = 0 - 70^\circ\text{C}$; $V_{DDL} = 2.5 \text{ V} \pm 5\%$; $C_L = 10\text{-}20 \text{ pF}$ (unless otherwise specified)

PARAMETER	SYMBOL	CONDITIONS	MIN	TYP	MAX	UNITS
Output Impedance	R_{DSP2B}^1	$V_O = V_{DD}^*(0.5)$	13.5	16	45	Ω
Output Impedance	R_{DSN2B}^1	$V_O = V_{DD}^*(0.5)$	13.5	21	45	Ω
Output High Voltage	V_{OH2B}	$I_{OH} = -1 \text{ mA}$	2			V
Output Low Voltage	V_{OL2B}	$I_{OL} = 1 \text{ mA}$			0.4	V
Output High Current	I_{OH2B}	$V_{OH @ MIN} = 1.0 \text{ V}$	-27	-68		mA
		$V_{OH @ MAX} = 2.375 \text{ V}$		-9	-27	
Output Low Current	I_{OL2B}	$V_{OL @ MIN} = 1.2 \text{ V}$	27	54		mA
		$V_{OL @ MAX} = 0.3 \text{ V}$		11	30	
Rise Time ¹	t_{r2B}	$V_{OL} = 0.4 \text{ V}$, $V_{OH} = 2.0 \text{ V}$	0.4	1.1	1.6	ns
Fall Time ¹	t_{f2B}	$V_{OH} = 2.0 \text{ V}$, $V_{OL} = 0.4 \text{ V}$	0.4	1.1	1.6	ns
Duty Cycle ¹	d_{l2B}	$V_T = 1.25 \text{ V}$	45	49	55	%
Skew window ¹	t_{sk2B}	$V_T = 1.25 \text{ V}$		45	175	ps
Jitter, Cycle-to-cycle ¹	$t_{jyc-cyc2B}$	$V_T = 1.25 \text{ V}$		135	250	ps

¹Guaranteed by design, not 100% tested in production.

Electrical Characteristics - 3V66

$T_A = 0 - 70^\circ\text{C}$; $V_{DD} = 3.3 \text{ V} \pm 5\%$; $C_L = 10\text{-}20 \text{ pF}$ (unless otherwise specified)

PARAMETER	SYMBOL	CONDITIONS	MIN	TYP	MAX	UNITS
Output Impedance	R_{DSP1B}^1	$V_O = V_{DD}^*(0.5)$	12	14	55	Ω
Output Impedance	R_{DSN1B}^1	$V_O = V_{DD}^*(0.5)$	12	14.5	55	Ω
Output High Voltage	V_{OH1}	$I_{OH} = -1 \text{ mA}$	2.4			V
Output Low Voltage	V_{OL1}	$I_{OL} = 1 \text{ mA}$			0.55	V
Output High Current	I_{OH1}	$V_{OH @ MIN} = 1.0 \text{ V}$	-33	-108		mA
		$V_{OH @ MAX} = 3.135 \text{ V}$		-9	-33	
Output Low Current	I_{OL1}	$V_{OL @ MIN} = 1.95 \text{ V}$	30	95		mA
		$V_{OL @ MAX} = 0.4 \text{ V}$		29	38	
Rise Time ¹	t_{r1}	$V_{OL} = 0.4 \text{ V}$, $V_{OH} = 2.4 \text{ V}$	0.4	1.2	1.6	ns
Fall Time ¹	t_{f1}	$V_{OH} = 2.4 \text{ V}$, $V_{OL} = 0.4 \text{ V}$	0.4	1.2	1.6	ns
Duty Cycle ¹	d_{t1}	$V_T = 1.5 \text{ V}$	45	49	55	%
Skew window ¹	t_{sk1}	$V_T = 1.5 \text{ V}$		135	175	ps
Jitter, Cycle-to-cycle ¹	$t_{jyc-cyc1}$	$V_T = 1.5 \text{ V}$		175	500	ps

¹Guaranteed by design, not 100% tested in production.



Electrical Characteristics - IOAPIC

T_A = 0 - 70C; V_{DDL} = 2.5 V +/-5%; C_L = 10-20 pF (unless otherwise specified)

PARAMETER	SYMBOL	CONDITIONS	MIN	TYP	MAX	UNITS
Output Impedance	R _{DSP4B} ¹	V _O = V _{DD} *(0.5)	9	16	30	Ω
Output Impedance	R _{DSN4B} ¹	V _O = V _{DD} *(0.5)	9	20	30	Ω
Output High Voltage	V _{OH4B}	I _{OH} = -1 mA	2			V
Output Low Voltage	V _{OL4B}	I _{OL} = 1 mA			0.4	V
Output High Current	I _{OH4B}	V _{OH @ MIN} = 1.0 V	-27	-68		mA
		V _{OH @ MAX} = 2.375 V		-9	-27	
Output Low Current	I _{OL4B}	V _{OL @ MIN} = 1.2 V	27	54		mA
		V _{OL @ MAX} = 0.3 V		11	30	
Rise Time ¹	t _{r4B}	V _{OL} = 0.4 V, V _{OH} = 2.0 V	0.4	1.1	1.6	ns
Fall Time ¹	t _{f4B}	V _{OH} = 2.0 V, V _{OL} = 0.4 V	0.4	1.1	1.6	ns
Duty Cycle ¹	d _{t4B}	V _T = 1.25 V	45	49	55	%
Jitter, Cycle-to-cycle ¹	t _{jyc-cyc4B}	V _T = 1.25 V		180	500	ps

¹Guaranteed by design, not 100% tested in production.

Electrical Characteristics - SDRAM

T_A = 0 - 70C; V_{DD} = 3.3 V +/-5%; C_L = 20-30 pF (unless otherwise specified)

PARAMETER	SYMBOL	CONDITIONS	MIN	TYP	MAX	UNITS
Output Impedance	R _{DSP3B} ¹	V _O = V _{DD} *(0.5)	10	12	24	Ω
Output Impedance	R _{DSN3B} ¹	V _O = V _{DD} *(0.5)	10	15	24	Ω
Output High Voltage	V _{OH3}	I _{OH} = -1 mA	2.4			V
Output Low Voltage	V _{OL3}	I _{OL} = 1 mA			0.4	V
Output High Current	I _{OH3}	V _{OH @ MIN} = 2.0 V	-54	-92		mA
		V _{OH @ MAX} = 3.135 V		-16	-46	
Output Low Current	I _{OL3}	V _{OL @ MIN} = 1.0 V	54	68		mA
		V _{OL @ MAX} = 0.4 V		29	53	
Rise Time ¹	t _{r3}	V _{OL} = 0.4 V, V _{OH} = 2.4 V	0.4	1	1.6	ns
Fall Time ¹	t _{f3}	V _{OH} = 2.4 V, V _{OL} = 0.4 V	0.4	1.5	1.6	ns
Duty Cycle ¹	d _{t3}	V _T = 1.5 V	45	52	55	%
Skew window ¹	t _{sk3}	V _T = 1.5 V		120	250	ps
Jitter, Cycle-to-cycle ¹	t _{jyc-cyc3}	V _T = 1.5 V		135	250	ps

¹Guaranteed by design, not 100% tested in production.



Electrical Characteristics - PCI

$T_A = 0 - 70^\circ\text{C}$; $V_{DD} = 3.3 \text{ V} \pm 5\%$; $C_L = 10\text{-}30 \text{ pF}$ (unless otherwise specified)

PARAMETER	SYMBOL	CONDITIONS	MIN	TYP	MAX	UNITS
Output Impedance	R_{DSP1B}^1	$V_O = V_{DD}*(0.5)$	12	15	55	Ω
Output Impedance	R_{DSN1B}^1	$V_O = V_{DD}*(0.5)$	12	15	55	Ω
Output High Voltage	V_{OH1}	$I_{OH} = -1 \text{ mA}$	2.4			V
Output Low Voltage	V_{OL1}	$I_{OL} = 1 \text{ mA}$			0.55	V
Output High Current	I_{OH1}	$V_{OH @ MIN} = 1.0 \text{ V}$	-33	-106		mA
		$V_{OH @ MAX} = 3.135 \text{ V}$		-14	-33	
Output Low Current	I_{OL1}	$V_{OL @ MIN} = 1.95 \text{ V}$	30	94		mA
		$V_{OL @ MAX} = 0.4 \text{ V}$		29	38	
Rise Time ¹	t_{r1}	$V_{OL} = 0.4 \text{ V}, V_{OH} = 2.4 \text{ V}$	0.4	1.3	2	ns
Fall Time ¹	t_{f1}	$V_{OH} = 2.4 \text{ V}, V_{OL} = 0.4 \text{ V}$	0.4	1.4	2	ns
Duty Cycle ¹	d_{t1}	$V_T = 1.5 \text{ V}$	45	51	55	%
Skew window ¹	t_{sk1}	$V_T = 1.5 \text{ V}$		20	500	ps
Jitter, Cycle-to-cycle ¹	$t_{j\text{cyc-cyc}1}$	$V_T = 1.5 \text{ V}$		175	500	ps

¹Guaranteed by design, not 100% tested in production.

Electrical Characteristics - REF, 48MHz_0 (Pin 26)

$T_A = 0 - 70^\circ\text{C}$; $V_{DD} = 3.3 \text{ V} \pm 5\%$; $C_L = 10\text{-}20 \text{ pF}$ (unless otherwise specified)

PARAMETER	SYMBOL	CONDITIONS	MIN	TYP	MAX	UNITS
Output Impedance	R_{DSP5B}^1	$V_O = V_{DD}*(0.5)$	20	29	60	Ω
Output Impedance	R_{DSN5B}^1	$V_O = V_{DD}*(0.5)$	20	27	60	Ω
Output High Voltage	V_{OH15}	$I_{OH} = -1 \text{ mA}$	2.4			V
Output Low Voltage	V_{OL5}	$I_{OL} = 1 \text{ mA}$			0.55	V
Output High Current	I_{OH5}	$V_{OH @ MIN} = 1.0 \text{ V}$	-29	-54		mA
		$V_{OH @ MAX} = 3.135 \text{ V}$		-11	-23	
Output Low Current	I_{OL5}	$V_{OL @ MIN} = 1.95 \text{ V}$	29	54		mA
		$V_{OL @ MAX} = 0.4 \text{ V}$		16	27	
Rise Time ¹	t_{r5}	$V_{OL} = 0.4 \text{ V}, V_{OH} = 2.4 \text{ V}$	0.4	1.3	4	ns
Fall Time ¹	t_{f5}	$V_{OH} = 2.4 \text{ V}, V_{OL} = 0.4 \text{ V}$	0.4	1.6	4	ns
Duty Cycle ¹	d_{t5}	$V_T = 1.5 \text{ V}$	45	53	55	%
Jitter, Cycle-to-cycle ¹	$t_{j\text{cyc-cyc}5}$	$V_T = 1.5 \text{ V}, \text{Fixed clocks}$		160	500	ps
Jitter, Cycle-to-cycle ¹	$t_{j\text{cyc-cyc}5}$	$V_T = 1.5 \text{ V}, \text{Ref clocks}$		420	1000	ps

¹Guaranteed by design, not 100% tested in production.



Electrical Characteristics - 48MHz_1 (Pin 27)

$T_A = 0 - 70C$; $V_{DD} = 3.3 V \pm 5\%$; $C_L = 10-15 pF$ (unless otherwise specified)

PARAMETER	SYMBOL	CONDITIONS	MIN	TYP	MAX	UNITS
Output Impedance	R_{DSP3B}^1	$V_O = V_{DD}*(0.5)$	10	15	24	Ω
Output Impedance	R_{DSN3B}^1	$V_O = V_{DD}*(0.5)$	10	15	24	Ω
Output High Voltage	V_{OH3}	$I_{OH} = -1 mA$	2.4			V
Output Low Voltage	V_{OL3}	$I_{OL} = 1 mA$			0.55	V
Output High Current	I_{OH3}	$V_{OH @ MIN} = 2.0 V$	-54	-82		mA
		$V_{OH @ MAX} = 3.135 V$		-20	-46	
Output Low Current	I_{OL3}	$V_{OL @ MIN} = 1.0 V$	54	95		mA
		$V_{OL @ MAX} = 0.4 V$		28	53	
Rise Time ¹	t_{r3}	$V_{OL} = 0.4 V, V_{OH} = 2.4 V$	0.4	1.1	1.6	ns
Fall Time ¹	t_{f3}	$V_{OH} = 2.4 V, V_{OL} = 0.4 V$	0.4	1.3	1.6	ns
Duty Cycle ¹	d_{f3}	$V_T = 1.5 V$	45	53	55	%
Jitter, Cycle-to-cycle ¹	$t_{jyc-cyc3B}$	$V_T = 1.5 V$		145	500	ps

¹Guaranteed by design, not 100% tested in production.



Group Skews (CPU 66 MHz, SDRAM 100MHz)

T_A = 0 - 70° C; V_{DD} = 3.3 V +/-5%, V_{DDL} = 2.5 V +/-5%

CPU & IOAPIC load (lumped) = 20 pF; PCI, SDRAM, 3V66 load (lumped) = 30 pF

Refer to Group Offset Waveforms diagram for definition of transition edges.

PARAMETER	SYMBOL	CONDITIONS	MIN	TYP	MAX	UNITS
CPU to SDRAM Skew ¹	T _{sk1} CPU-SDRAM	CPU @ 1.25 V, SDRAM @ 1.5 V	-3	-2.7	-2	ns
Skew Window ¹	T _{w1} CPU-SDRAM		0	165	500	ps
CPU to 3V66 Skew ¹	T _{sk1} CPU-3V66	CPU @ 1.25 V, 3V66 @ 1.5 V	7	7.6	8	ns
Skew Window ¹	T _{w1} CPU-3V66		0	105	500	ps
SDRAM to 3V66 Skew ¹	T _{sk1} SDRAM-3V66	SDRAM, 3V66 @ 1.5 V	-500	180	500	ps
Skew Window ¹	T _{w1} SDRAM-3V66		0	210	500	ps
3V66 to PCI Skew ¹	T _{sk1} 3V66-PCI	3V66, PCI @ 1.5 V	1.5	2.1	3.5	ns
Skew Window ¹	T _{w1} 3V66-PCI		0	90	500	ps
IOAPIC to PCI Skew ¹	T _{sk1} IOAPIC-PCI	IOAPIC @ 1.25 V, PCI @ 1.5 V	-1	-0.1	1	ns
Skew Window ¹	T _{w1} IOAPIC-PCI		0	0	1	ns

¹Guaranteed by design, not 100% tested in production.

Group Skews (CPU 100 MHz, SDRAM 100MHz)

T_A = 0 - 70° C; V_{DD} = 3.3 V +/-5%, V_{DDL} = 2.5 V +/-5%

CPU & IOAPIC load (lumped) = 20 pF; PCI, SDRAM, 3V66 load (lumped) = 30 pF

Refer to Group Offset Waveforms diagram for definition of transition edges.

PARAMETER	SYMBOL	CONDITIONS	MIN	TYP	MAX	UNITS
CPU to SDRAM Skew ¹	T _{sk2} CPU-SDRAM	CPU @ 1.25 V, SDRAM @ 1.5 V	4.5	4.9	5.5	ns
Skew Window ¹	T _{w2} CPU-SDRAM		0	180	500	ps
CPU to 3V66 Skew ¹	T _{sk2} CPU-3V66	CPU @ 1.25 V, 3V66 @ 1.5 V	4.5	5	5.5	ns
Skew Window ¹	T _{w2} CPU-3V66		0	100	500	ps
SDRAM to 3V66 Skew ¹	T _{sk2} SDRAM-3V66	SDRAM, 3V66 @ 1.5 V	-500	175	500	ps
Skew Window ¹	T _{w2} SDRAM-3V66		0	200	500	ps
3V66 to PCI Skew ¹	T _{sk2} 3V66-PCI	3V66, PCI @ 1.5 V	1.5	2.1	3.5	ns
Skew Window ¹	T _{w2} 3V66-PCI		0	90	500	ps
IOAPIC to PCI Skew ¹	T _{sk2} IOAPIC-PCI	IOAPIC @ 1.25 V, PCI @ 1.5 V	-1	-0.1	1	ns
Skew Window ¹	T _{w2} IOAPIC-PCI		0	0	1	ns

¹Guaranteed by design, not 100% tested in production.



Group Skews (CPU 133 MHz, SDRAM 133MHz)

$T_A = 0 - 70^\circ C$; $V_{DD} = 3.3 V \pm 5\%$, $V_{DDL} = 2.5 V \pm 5\%$

CPU & IOAPIC load (lumped) = 20 pF; PCI, SDRAM, 3V66 load (lumped) = 30 pF

Refer to Group Offset Waveforms diagram for definition of transition edges.

PARAMETER	SYMBOL	CONDITIONS	MIN	TYP	MAX	UNITS
CPU to SDRAM Skew ¹	$T_{sk3 CPU-SDRAM}$	CPU @ 1.25 V, SDRAM @ 1.5 V	3.25	3.45	4.25	ns
Skew Window ¹	$T_{w3 CPU-SDRAM}$		0	155	500	ps
CPU to 3V66 Skew ¹	$T_{sk3 CPU-3V66}$	CPU @ 1.25 V, 3V66 @ 1.5 V	-500	120	500	ps
Skew Window ¹	$T_{w3 CPU-3V66}$		0	120	500	ps
SDRAM to 3V66 Skew ¹	$T_{sk3 SDRAM-3V66}$	SDRAM, 3V66 @ 1.5 V	-3.25	-3.08	-4.25	ps
Skew Window ¹	$T_{w3 SDRAM-3V66}$		0	175	500	ps
3V66 to PCI Skew ¹	$T_{sk3 3V66-PCI}$	3V66, PCI @ 1.5 V	1.5	2.2	3.5	ns
Skew Window ¹	$T_{w3 3V66-PCI}$		0	80	500	ps
IOAPIC to PCI Skew ¹	$T_{sk3 IOAPIC-PCI}$	IOAPIC @ 1.25 V, PCI @ 1.5 V	-1	-0.1	1	ns
Skew Window ¹	$T_{w3 IOAPIC-PCI}$		0	0	1	ns

¹Guaranteed by design, not 100% tested in production.

Group Skews (CPU133 MHz, SDRAM 100MHz)

$T_A = 0 - 70^\circ C$; $V_{DD} = 3.3 V \pm 5\%$, $V_{DDL} = 2.5 V \pm 5\%$

CPU & IOAPIC load (lumped) = 20 pF; PCI, SDRAM, 3V66 load (lumped) = 30 pF

Refer to Group Offset Waveforms diagram for definition of transition edges.

PARAMETER	SYMBOL	CONDITIONS	MIN	TYP	MAX	UNITS
CPU to SDRAM Skew ¹	$T_{sk3 CPU-SDRAM}$	CPU @ 1.25 V, SDRAM @ 1.5 V	-500	-15	500	ps
Skew Window ¹	$T_{w3 CPU-SDRAM}$		0	165	500	ps
CPU to 3V66 Skew ¹	$T_{sk3 CPU-3V66}$	CPU @ 1.25 V, 3V66 @ 1.5 V	-500	165	500	ps
Skew Window ¹	$T_{w3 CPU-3V66}$		0	105	500	ps
SDRAM to 3V66 Skew ¹	$T_{sk3 SDRAM-3V66}$	SDRAM, 3V66 @ 1.5 V	-500	185	500	ps
Skew Window ¹	$T_{w3 SDRAM-3V66}$		0	185	500	ps
3V66 to PCI Skew ¹	$T_{sk3 3V66-PCI}$	3V66, PCI @ 1.5 V	1.5	2.2	3.5	ns
Skew Window ¹	$T_{w3 3V66-PCI}$		0	60	500	ps
IOAPIC to PCI Skew ¹	$T_{sk3 IOAPIC-PCI}$	IOAPIC @ 1.25 V, PCI @ 1.5 V	-1	-0.1	1	ns
Skew Window ¹	$T_{w3 IOAPIC-PCI}$		0	0	1	ns

¹Guaranteed by design, not 100% tested in production.

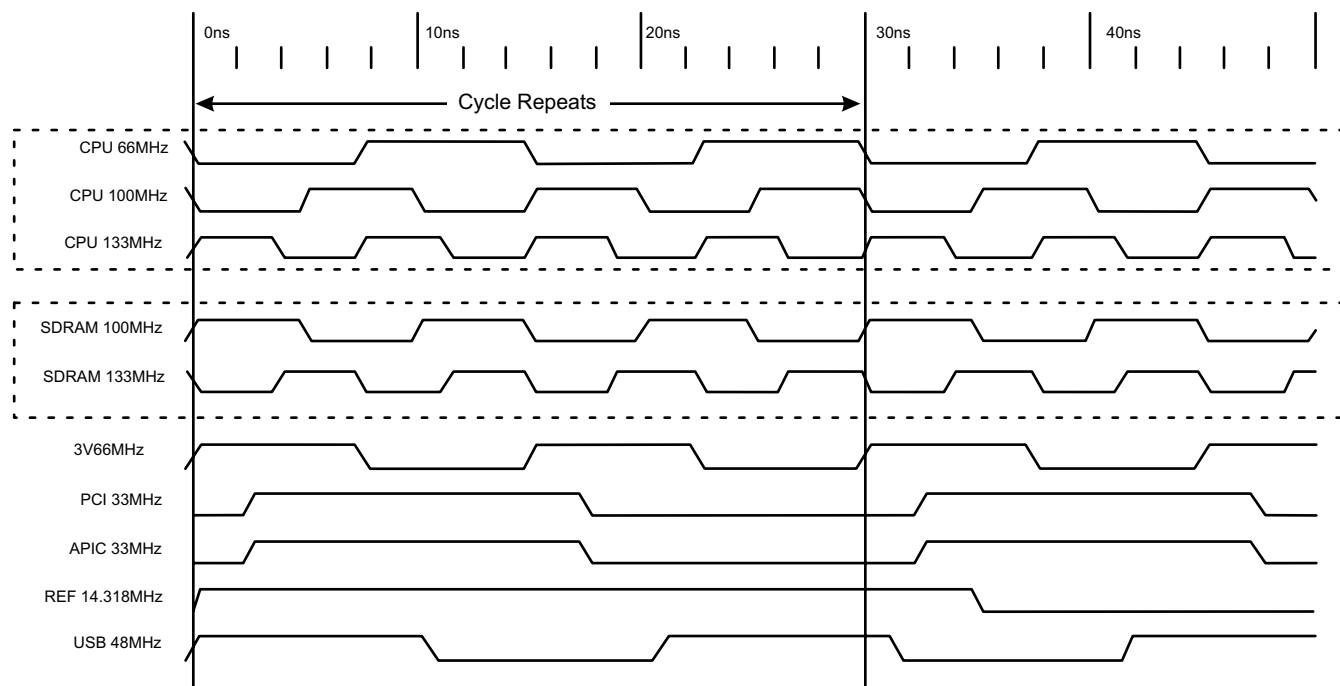

Group Offset Waveforms



General I²C serial interface information

The information in this section assumes familiarity with I²C programming.
For more information, contact ICS for an I²C programming application note.

How to Write:

- Controller (host) sends a start bit.
- Controller (host) sends the write address D2_(H)
- ICS clock will *acknowledge*
- Controller (host) sends a dummy command code
- ICS clock will *acknowledge*
- Controller (host) sends a dummy byte count
- ICS clock will *acknowledge*
- Controller (host) starts sending first byte (Byte 0) through byte 5
- ICS clock will *acknowledge* each byte *one at a time*.
- Controller (host) sends a Stop bit

How to Write:	
Controller (Host)	ICS (Slave/Receiver)
Start Bit	
Address D2 _(H)	
	ACK
Dummy Command Code	
	ACK
Dummy Byte Count	
	ACK
Byte 0	
	ACK
Byte 1	
	ACK
Byte 2	
	ACK
Byte 3	
	ACK
Byte 4	
	ACK
Byte 5	
	ACK
Stop Bit	

How to Read:

- Controller (host) will send start bit.
- Controller (host) sends the read address D3_(H)
- ICS clock will *acknowledge*
- ICS clock will send the *byte count*
- Controller (host) acknowledges
- ICS clock sends first byte (*Byte 0*) through *byte 5*
- Controller (host) will need to acknowledge each byte
- Controller (host) will send a stop bit

How to Read:	
Controller (Host)	ICS (Slave/Receiver)
Start Bit	
Address D3 _(H)	
	ACK
	Byte Count
ACK	
	Byte 0
ACK	
	Byte 1
ACK	
	Byte 2
ACK	
	Byte 3
ACK	
	Byte 4
ACK	
	Byte 5
ACK	
Stop Bit	

Notes:

1. The ICS clock generator is a slave/receiver, I²C component. It can read back the data stored in the latches for verification. **Read-Back will support Intel PIIX4 "Block-Read" protocol.**
2. The data transfer rate supported by this clock generator is 100K bits/sec or less (standard mode)
3. The input is operating at 3.3V logic levels.
4. The data byte format is 8 bit bytes.
5. To simplify the clock generator I²C interface, the protocol is set to use only "**Block-Writes**" from the controller. The bytes must be accessed in sequential order from lowest to highest byte with the ability to stop after any complete byte has been transferred. The Command code and Byte count shown above must be sent, but the data is ignored for those two bytes. The data is loaded until a Stop sequence is issued.
6. At power-on, all registers are set to a default condition, as shown.

ICS9250-28



General Layout Precautions:

- 1) Use a ground plane on the top routing layer of the PCB in all areas not used by traces.
- 2) Make all power traces and ground traces as wide as the via pad for lower inductance.

Notes:

- ① All clock outputs should have provisions for a 15pF capacitor between the clock output and series terminating resistor. Not shown in all places to improve readability of diagram.
- ② Optional crystal load capacitors are recommended. They should be included in the layout but not inserted unless needed.

Component Values:

- C1 : Crystal load values determined by user
 C2 : 22 μ F/20V/D case/Tantalum
 AVX TAJD226M020R
 C3 : 15pF capacitor
 FB = Fair-Rite products 2512066017X1
 All unmarked capacitors are 0.01 μ F ceramic

Connections to VDD:

- Best
- Okay
- Avoid
- Avoid

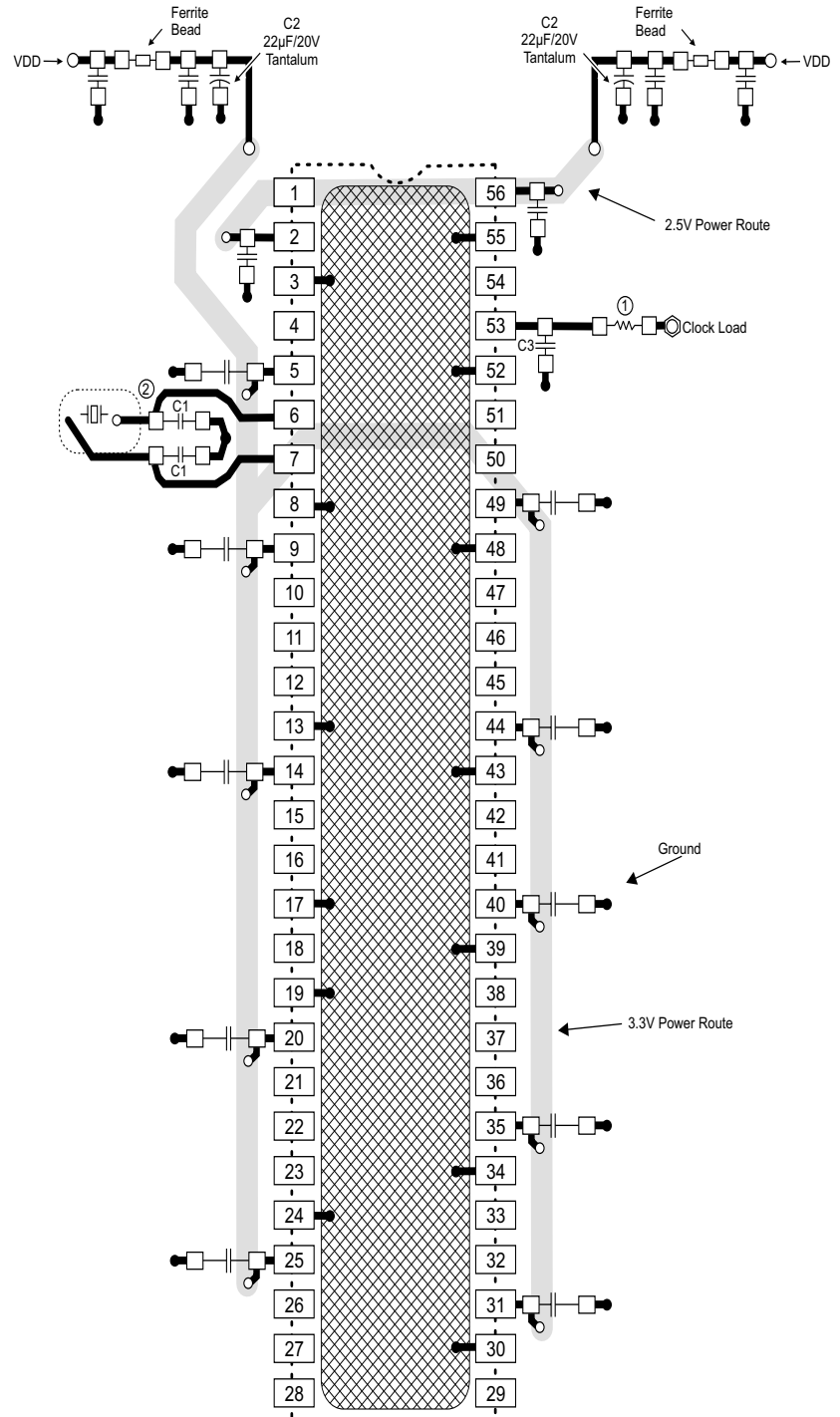

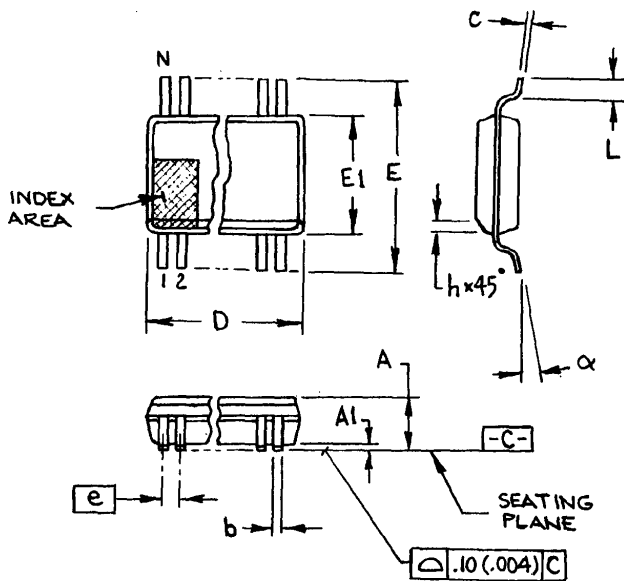

300 mil SSOP

SYMBOL	In Millimeters		In Inches	
	COMMON DIMENSIONS		COMMON DIMENSIONS	
	MIN	MAX	MIN	MAX
A	2.413	2.794	.095	.110
A1	0.203	0.406	.008	.016
b	0.203	0.343	.008	.0135
c	0.127	0.254	.005	.010
D	SEE VARIATIONS		SEE VARIATIONS	
E	10.033	10.668	.395	.420
E1	7.391	7.595	.291	.299
e	0.635 BASIC		0.025 BASIC	
h	0.381	0.635	.015	.025
L	0.508	1.016	.020	.040
N	SEE VARIATIONS		SEE VARIATIONS	
alpha	0°	8°	0°	8°

VARIATIONS

N	D mm.		D (inch)	
	MIN	MAX	MIN	MAX
28	9.398	9.652	.370	.380
34	11.303	11.557	.445	.455
48	15.748	16.002	.620	.630
56	18.288	18.542	.720	.730
64	20.828	21.082	.820	.830

Ordering Information

ICS9250yF-28-T

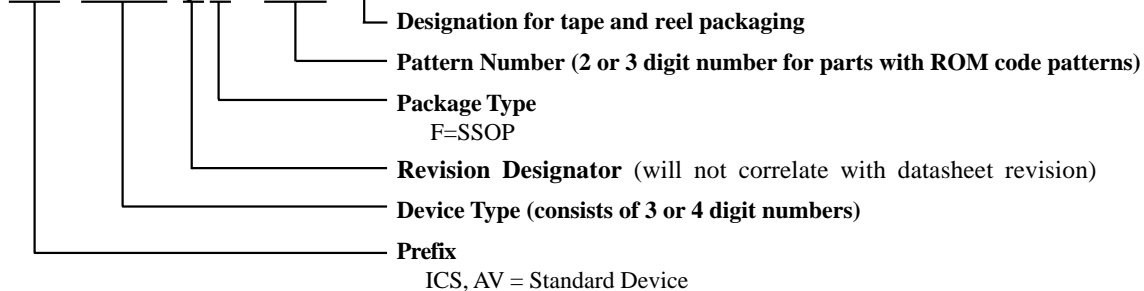

Example:

ICS XXXX y F - PPP - T



Looking for pricing, stock, or lifecycle information?

Click below to explore more details on WIN SOURCE:

-  [View ICS9250BF-28 on WIN SOURCE](#)
-  [IDT, Integrated Device Technology Inc Information](#)

Optimize Your Supply Chain with WIN SOURCE Solutions

-  Global Sourcing Solution
-  Obsolete Management
-  Cost Control Management
-  Shortage Management
-  Alternative Solution
-  Excess Inventory Management