

BGB741L7ESD

Pre-matched general purpose LNA MMIC for 50 MHz- 3.5 GHz applications



Order now



Technical documents



Simulation



Support

Product description

The BGB741L7ESD is a high performance broadband low noise amplifier (LNA) MMIC based on Infineon's silicon germanium carbon (SiGe:C) bipolar technology.



Feature list

- Minimum noise figure $NF_{min} = 1.05$ dB at 2.4 GHz, 3 V, 10 mA
- Supply voltage range $V_{CC} = 1.8$ to 4.0 V at $T_A = 25$ °C
- High RF input power robustness of 20 dBm
- Integrated ESD protection: 2 kV HBM at all pins

Product validation

Qualified for industrial applications according to the relevant tests of JEDEC47/20/22.

Potential applications

- Satellite navigation systems (e.g. GPS, GLONASS, BeiDou, Galileo)
- Wireless communications: WLAN 2.4 GHz and 5-6 GHz bands, broadband LTE or WIMAX LNA
- ISM applications like RKE and smart meter, as well as for emerging wireless applications such as DVB-Terrestrial

Device information

Table 1 Part information

Product name / Ordering code	Package	Pin configuration				Marking	Pieces / Reel
BGB741L7ESD / BGB741L7ESDE6327XTSA1	TSLP-7-1	1 = V_{CC}	2 = V_{Bias}	3 = RF_{in}	4 = RF_{out}	AY	7500
		5 = V_{Ctrl}	6 = Current adjust	7 = Ground			

Attention: ESD (Electrostatic discharge) sensitive device, observe handling precautions

Functional block diagram

Functional block diagram

This functional block diagram explains how the BGB707L7ESD is used. The RF power on/off function is controlled by applying V_{Ctrl} . By using an external resistor R_{ext} , the pre-set current of 5.5 mA (when R_{ext} is omitted) can be increased. Base V_B and collector V_C voltages are applied to the respective pins RF_{in} and RF_{out} by external inductors L_B and L_C .

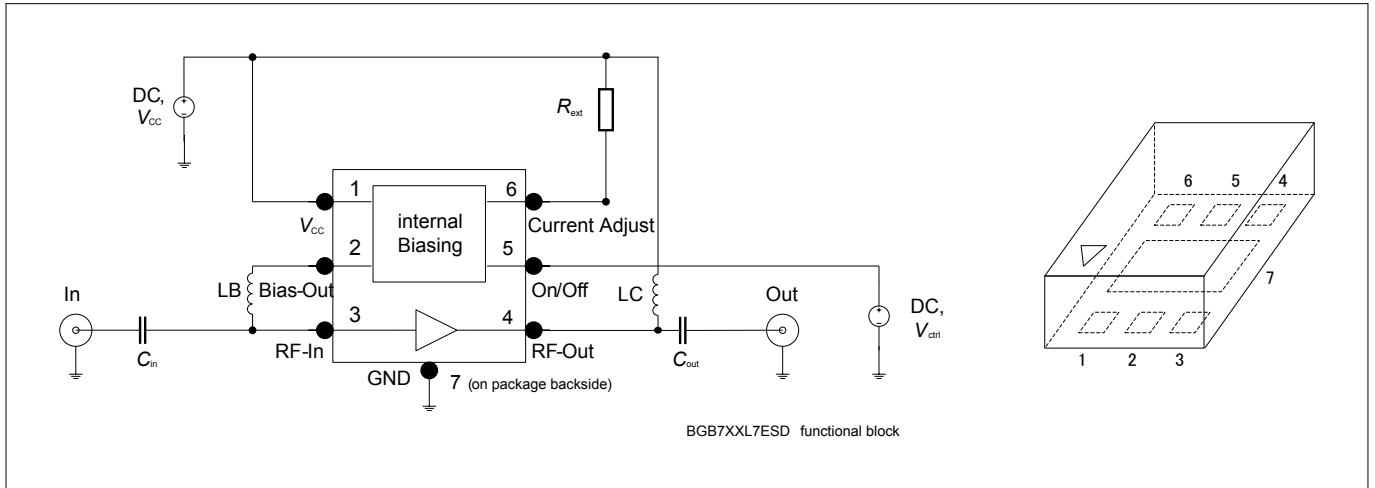

Figure 1 Functional block diagram

Table of contents

	Product description	1
	Feature list	1
	Product validation	1
	Potential applications	1
	Device information	1
	Functional block diagram	2
	Table of contents	3
1	Operating conditions	4
2	Absolute maximum ratings	5
3	Thermal characteristics	6
4	Electrical characteristics	7
4.1	DC characteristics	7
4.2	Characteristic DC diagrams	8
4.3	AC characteristics	10
5	Package information TSLP-7-1	19
	Revision history	20
	Disclaimer	21

Operating conditions**1 Operating conditions****Table 2 Operation conditions at $T_A = 25\text{ °C}$**

Parameter	Symbol	Values			Unit	Note or test condition
		Min.	Typ.	Max.		
Supply voltage	V_{CC}	1.8	3	4	V	–
Control voltage in on-mode	$V_{Ctrl-on}$	1.2	–	V_{CC}		
Control voltage in off-mode	$V_{Ctrl-off}$	-0.3		0.3		

Absolute maximum ratings

2 Absolute maximum ratings

Table 3 Absolute maximum ratings at $T_A = 25\text{ °C}$ (unless otherwise specified)

Parameter	Symbol	Values		Unit	Note or test condition
		Min.	Max.		
Supply voltage	V_{CC}	-	4	V	$T_A = 25\text{ °C}$ $T_A = -55\text{ °C}$
			3.5		
Supply current	I_{CC}		30	mA	-
DC current at RF_{in}	I_B		3		
Control voltage	V_{Ctrl}		V_{CC}	V	
ESD stress pulse (HBM)	V_{ESD}		+/- 2	kV	
RF input power	$P_{RF_{in}}$		20	dBm	
Total power dissipation ¹⁾	P_{tot}		120	mW	$T_S \leq 117\text{ °C}$
Junction temperature	T_J	150	°C	-	
Storage temperature	T_{Stg}	-55			

Attention: Stresses above the max. values listed here may cause permanent damage to the device. Exposure to absolute maximum rating conditions for extended periods may affect device reliability. Exceeding only one of these values may cause irreversible damage to the integrated circuit.

¹⁾ T_S is the soldering point temperature. T_S is measured on the emitter lead at the soldering point of the PCB

Thermal characteristics

3 Thermal characteristics

Table 4 Thermal resistance

Parameter	Symbol	Values			Unit	Note or test condition
		Min.	Typ.	Max.		
Junction - soldering point	R_{thJS}	-	275	-	K/W	-

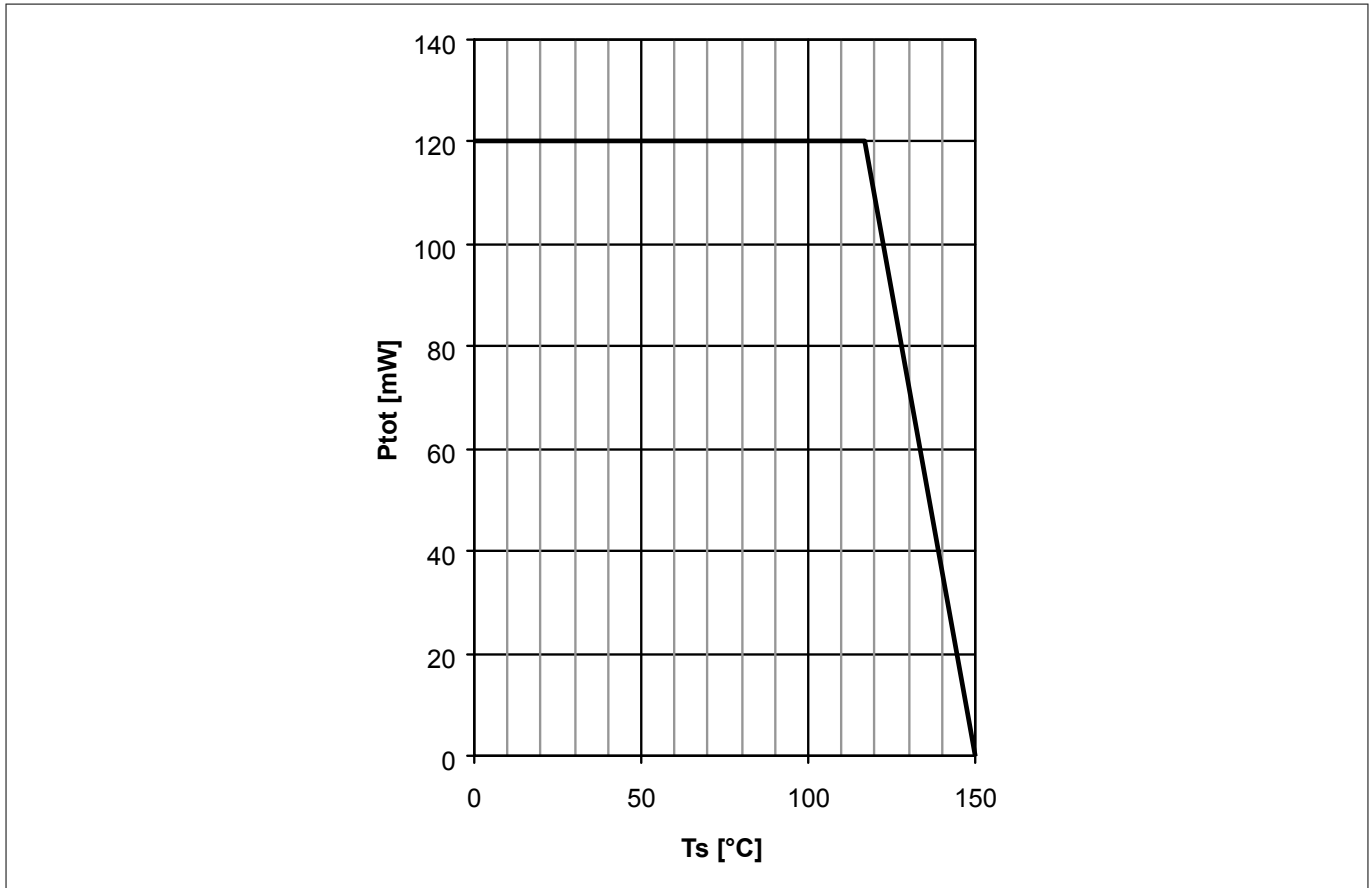

Figure 2 Total power dissipation $P_{tot} = f(T_s)$

Electrical characteristics

4 Electrical characteristics

4.1 DC characteristics

Table 5 DC characteristics at $V_{CC} = 3\text{ V}$, $T_A = 25\text{ °C}$

Parameter	Symbol	Values			Unit	Note or test condition
		Min.	Typ.	Max.		
Supply current in on-mode	I_{CC-on}	5.0	5.5	6.5	mA	$V_{Ctrl} = 3\text{ V}$ $R_{ext} = \text{open}$ $R_{ext} = 30\text{ k}\Omega$ $R_{ext} = 3\text{ k}\Omega$
		–	6	–		
		–	10	–		
Supply current in off-mode	I_{CC-off}	–	–	6	μA	$V_{Ctrl} = 0\text{ V}$
Control current in on-mode	$I_{Ctrl-on}$		14	20		$V_{Ctrl} = 3\text{ V}$
Control current in off-mode	$I_{Ctrl-off}$		–	0.1		$V_{Ctrl} = 0\text{ V}$

Electrical characteristics

4.2 Characteristic DC diagrams

The measurement setup is an application circuit according to Figure 1 on page 2, using the integrated biasing. $T_A = 25\text{ }^\circ\text{C}$ (unless otherwise specified).

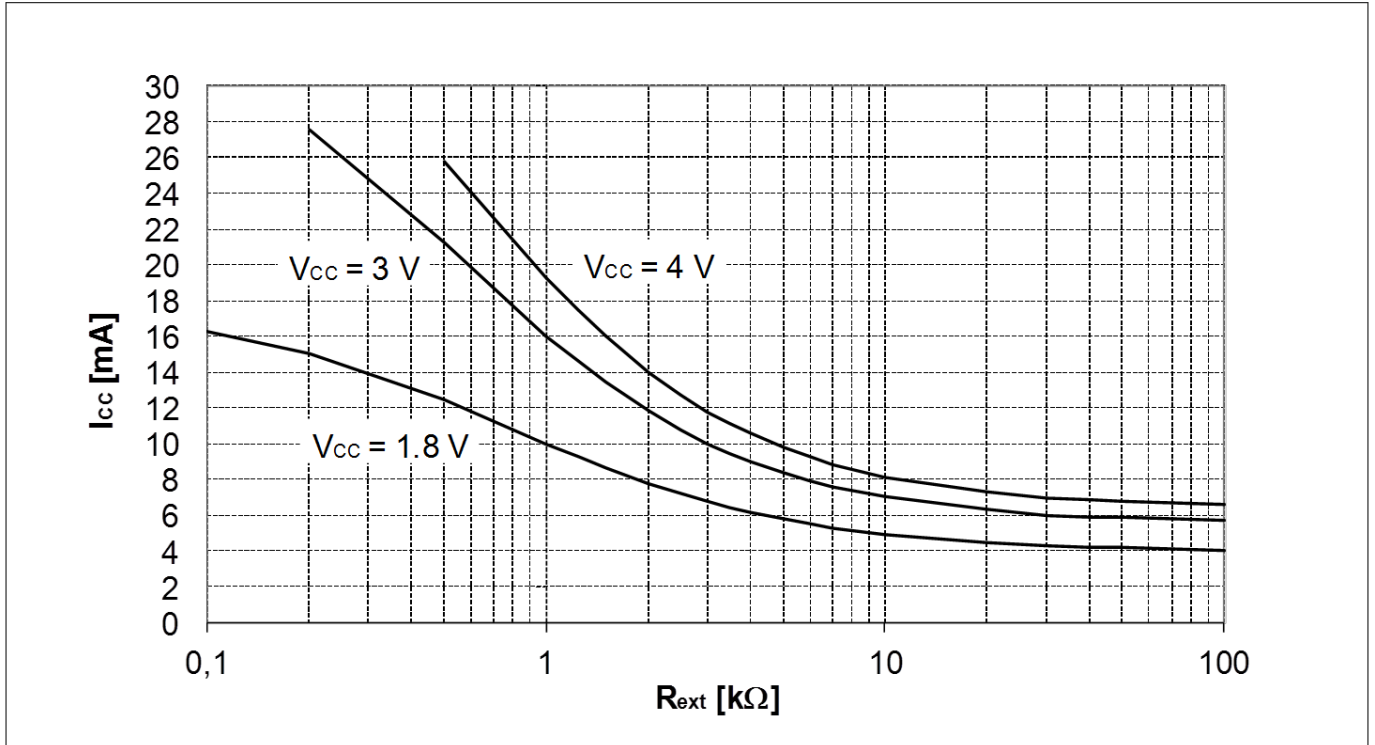

Figure 3 Supply current vs external resistance $I_{CC} = f(R_{ext}), V_{Ctrl} = 3\text{ V}, V_{CC} = \text{parameter}$

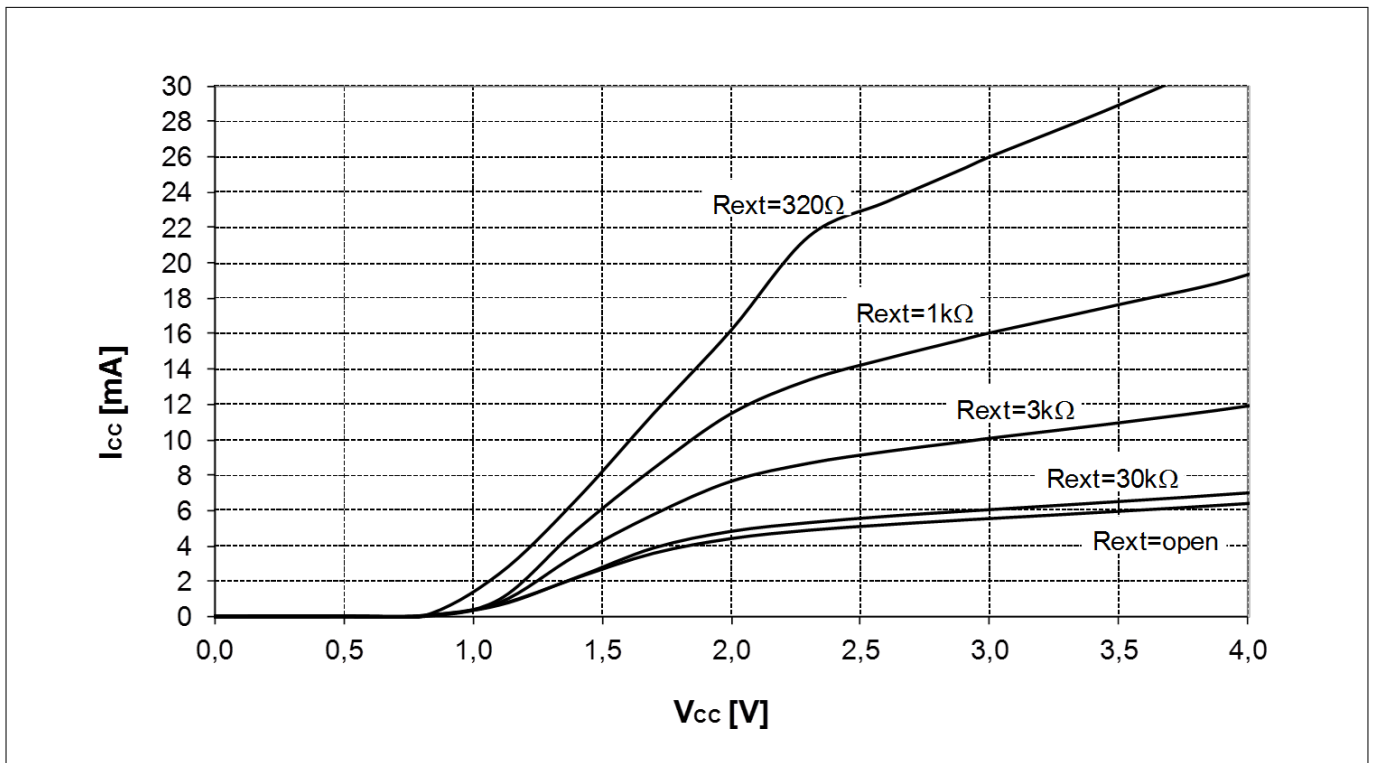

Figure 4 Supply current vs supply voltage $I_{CC} = f(V_{CC}), V_{Ctrl} = 3\text{ V}, R_{ext} = \text{parameter}$

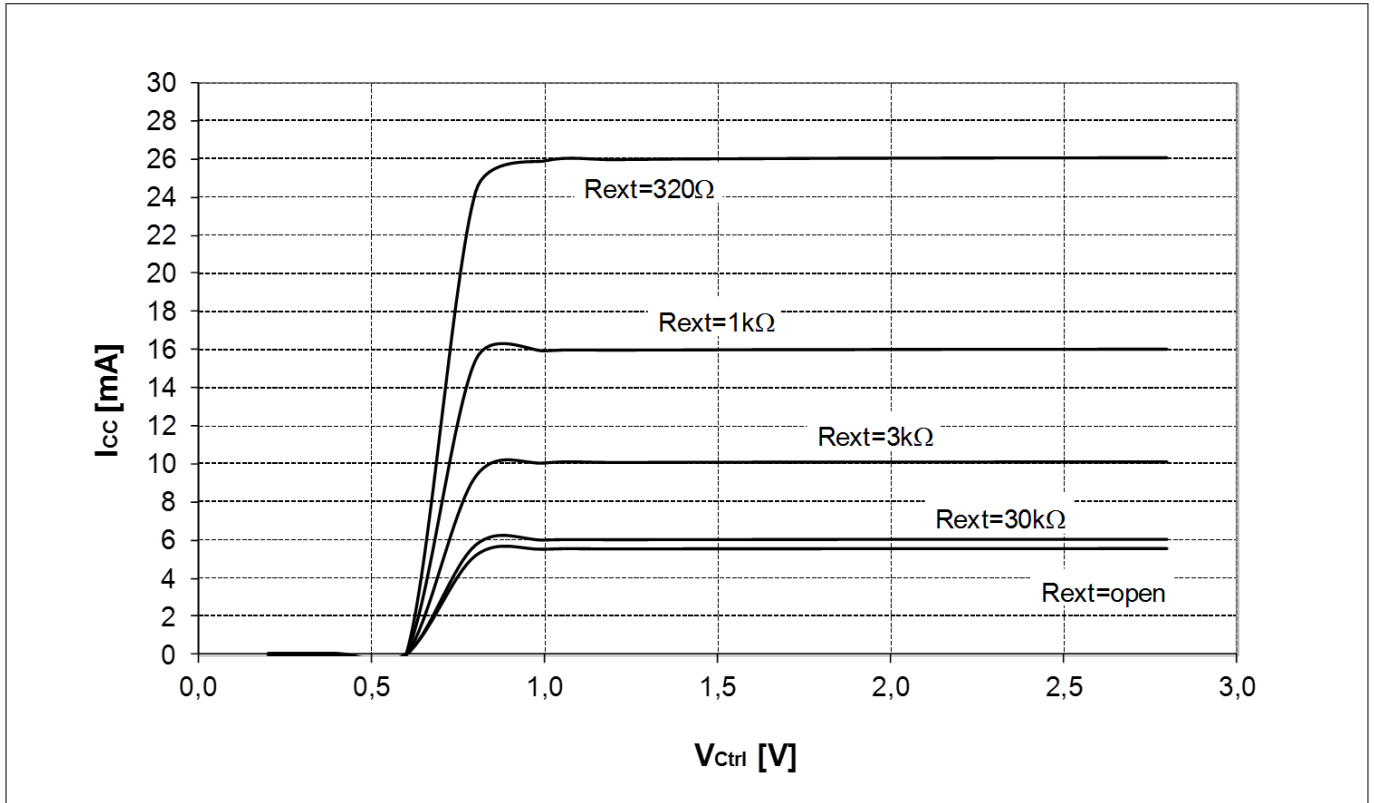

Figure 5 Supply current vs control voltage $I_{CC} = f(V_{Ctrl})$, $V_{CC} = 3$ V, $R_{ext} =$ parameter

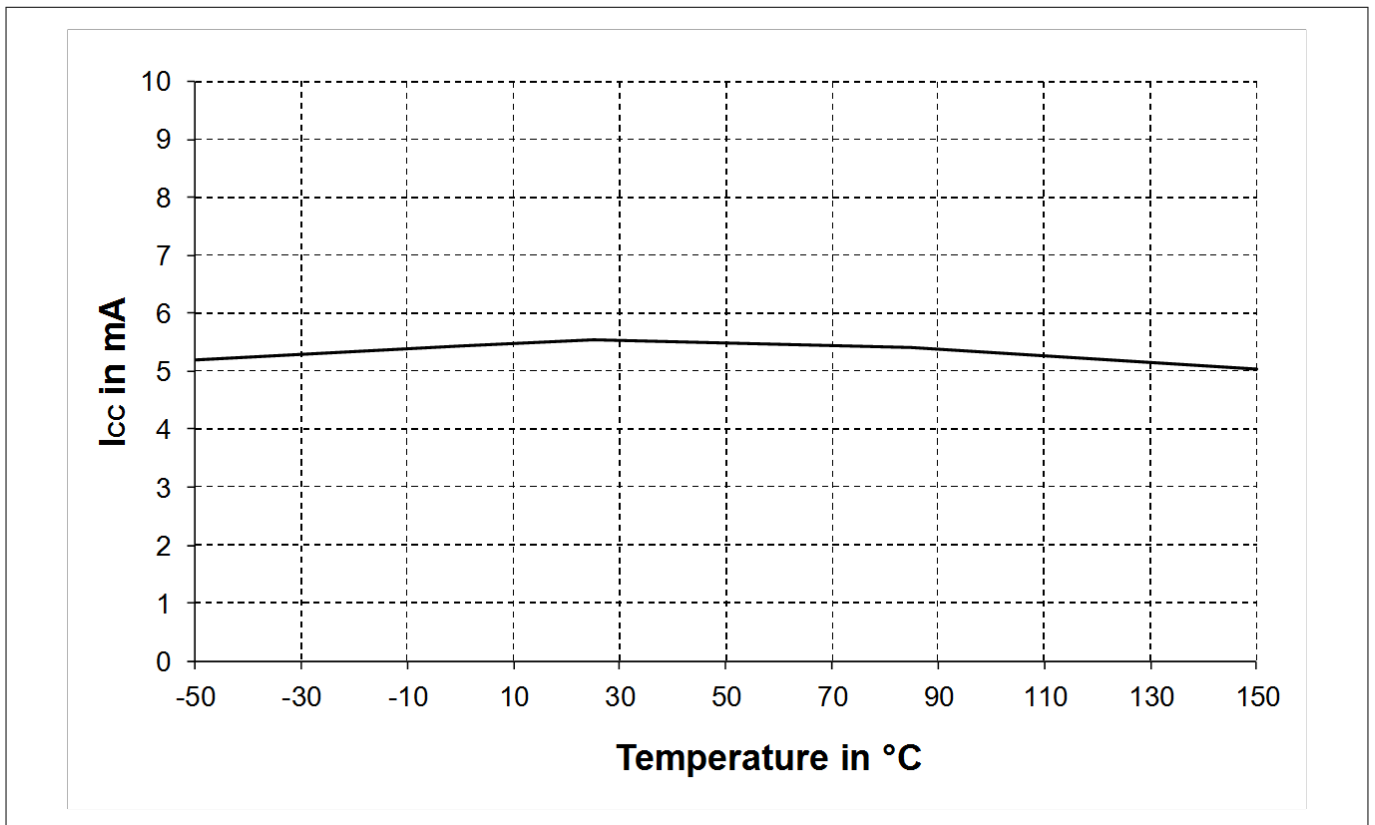

Figure 6 Supply current vs temperature $I_{CC} = f(T_A)$, $V_{Ctrl} = V_{CC} = 3$ V, $R_{ext} = open$

4.3 AC characteristics

The measurement setup is a test fixture with Bias-T's in a 50 Ω system, $T_A = 25\text{ °C}$.

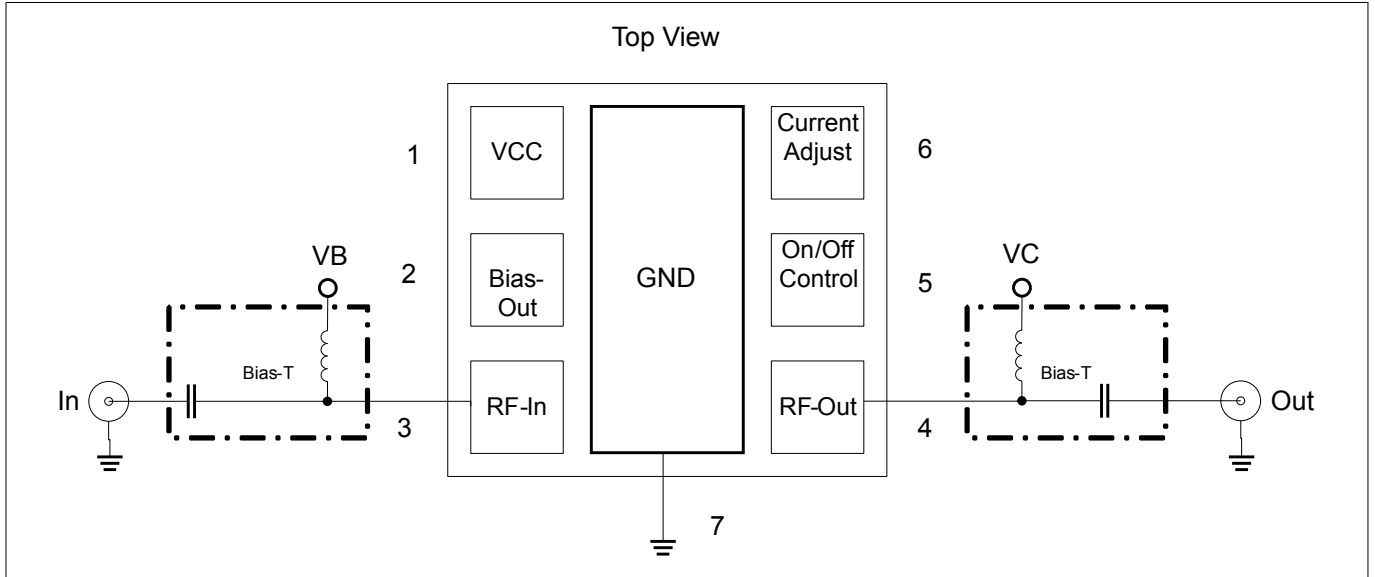

Figure 7 Testing setup

Electrical characteristics

Table 6 AC characteristics, $V_C = 3\text{ V}$, $f = 150\text{ MHz}$

Parameter	Symbol	Values			Unit	Note or test condition
		Min.	Typ.	Max.		
Minimum noise figure ²⁾	NF_{\min}	–	1.05 0.95	–	dB	$I_C = 6\text{ mA}$ $I_C = 10\text{ mA}$ $Z_S = Z_{S,\text{opt}}$
Noise figure in 50 Ω system ³⁾	NF_{50}		1.1 1.05			$I_C = 6\text{ mA}$ $I_C = 10\text{ mA}$ $Z_S = Z_L = 50\ \Omega$
Transducer gain	$ S_{21} ^2$		19 21		dB	$I_C = 6\text{ mA}$ $I_C = 10\text{ mA}$
Maximum stable power gain	G_{ms}		20 21.5			$I_C = 6\text{ mA}$ $I_C = 10\text{ mA}$
Input 1 dB gain compression point	$IP_{1\text{dB}}$		-5.5 -8		dBm	$I_{Cq} = 6\text{ mA}$ $I_{Cq} = 10\text{ mA}$
Input 3 rd order intercept point	IIP_3		5.5 3.5			$I_C = 6\text{ mA}$ $I_C = 10\text{ mA}$
Input return loss	RL_{in}		14 18		dB	$I_C = 6\text{ mA}$ $I_C = 10\text{ mA}$
Output return loss	RL_{out}		12.5 18.5			$I_C = 6\text{ mA}$ $I_C = 10\text{ mA}$

²⁾ Test fixture losses are extracted

³⁾ Parameter measured on an application board according to Figure 1 on page 2 presenting a 50 Ω system to the device. I_{Cq} is the quiescent current, that is at small RF input power level. I_C increases as RF input power level approaches $IP_{1\text{dB}}$.

Electrical characteristics

Table 7 AC characteristics, $V_C = 3\text{ V}$, $f = 450\text{ MHz}$

Parameter	Symbol	Values			Unit	Note or test condition
		Min.	Typ.	Max.		
Minimum noise figure ²⁾	NF_{\min}	–	1.05 0.95	–	dB	$I_C = 6\text{ mA}$ $I_C = 10\text{ mA}$ $Z_S = Z_{S,\text{opt}}$
Noise figure in 50 Ω system ³⁾	NF_{50}		1.1 1.05			$I_C = 6\text{ mA}$ $I_C = 10\text{ mA}$ $Z_S = Z_L = 50\ \Omega$
Transducer gain	$ S_{21} ^2$		18.5 20.5		dB	$I_C = 6\text{ mA}$ $I_C = 10\text{ mA}$
Maximum available power gain	G_{ma}		19 20.5			$I_C = 6\text{ mA}$ $I_C = 10\text{ mA}$
Input 1 dB gain compression point	$IP_{1\text{dB}}$		-5 -7.5		dBm	$I_{Cq} = 6\text{ mA}$ $I_{Cq} = 10\text{ mA}$
Input 3 rd order intercept point	IIP_3		4 2.5			$I_C = 6\text{ mA}$ $I_C = 10\text{ mA}$
Input return loss	RL_{in}		15.5 21		dB	$I_C = 6\text{ mA}$ $I_C = 10\text{ mA}$
Output return loss	RL_{out}		14.5 28			$I_C = 6\text{ mA}$ $I_C = 10\text{ mA}$

²⁾ Test fixture losses are extracted

³⁾ Parameter measured on an application board according to Figure 1 on page 2 presenting a 50 Ω system to the device. I_{Cq} is the quiescent current, that is at small RF input power level. I_C increases as RF input power level approaches $IP_{1\text{dB}}$.

Electrical characteristics

Table 8 AC characteristics, $V_C = 3\text{ V}$, $f = 900\text{ MHz}$

Parameter	Symbol	Values			Unit	Note or test condition
		Min.	Typ.	Max.		
Minimum noise figure ²⁾	NF_{\min}	–	1.05 0.95	–	dB	$I_C = 6\text{ mA}$ $I_C = 10\text{ mA}$ $Z_S = Z_{S,\text{opt}}$
Noise figure in 50 Ω system ³⁾	NF_{50}		1.1 1.05			$I_C = 6\text{ mA}$ $I_C = 10\text{ mA}$ $Z_S = Z_L = 50\ \Omega$
Transducer gain	$ S_{21} ^2$		18.5 20		dB	$I_C = 6\text{ mA}$ $I_C = 10\text{ mA}$
Maximum available power gain	G_{ma}		19 20.5			$I_C = 6\text{ mA}$ $I_C = 10\text{ mA}$
Input 1 dB gain compression point	$IP_{1\text{dB}}$		-5 -7		dBm	$I_{Cq} = 6\text{ mA}$ $I_{Cq} = 10\text{ mA}$
Input 3 rd order intercept point	IIP_3		3 1.5			$I_C = 6\text{ mA}$ $I_C = 10\text{ mA}$
Input return loss	RL_{in}		15.5 19		dB	$I_C = 6\text{ mA}$ $I_C = 10\text{ mA}$
Output return loss	RL_{out}		14.5 28.5			$I_C = 6\text{ mA}$ $I_C = 10\text{ mA}$

²⁾ Test fixture losses are extracted

³⁾ Parameter measured on an application board according to Figure 1 on page 2 presenting a 50 Ω system to the device. I_{Cq} is the quiescent current, that is at small RF input power level. I_C increases as RF input power level approaches $IP_{1\text{dB}}$.

Electrical characteristics

Table 9 AC characteristics, $V_C = 3\text{ V}$, $f = 1.5\text{ GHz}$

Parameter	Symbol	Values			Unit	Note or test condition
		Min.	Typ.	Max.		
Minimum noise figure ²⁾	NF_{\min}	–	1.05 1.0	–	dB	$I_C = 6\text{ mA}$ $I_C = 10\text{ mA}$ $Z_S = Z_{S,\text{opt}}$
Noise figure in 50 Ω system ³⁾	NF_{50}		1.1 1.05			$I_C = 6\text{ mA}$ $I_C = 10\text{ mA}$ $Z_S = Z_L = 50\ \Omega$
Transducer gain	$ S_{21} ^2$		18 19.5		dB	$I_C = 6\text{ mA}$ $I_C = 10\text{ mA}$
Maximum available power gain	G_{ma}		18.5 20			$I_C = 6\text{ mA}$ $I_C = 10\text{ mA}$
Input 1 dB gain compression point	$IP_{1\text{dB}}$		-4.5 -6.5		dBm	$I_{Cq} = 6\text{ mA}$ $I_{Cq} = 10\text{ mA}$
Input 3 rd order intercept point	IIP_3		2.5 1			$I_C = 6\text{ mA}$ $I_C = 10\text{ mA}$
Input return loss	RL_{in}		14.5 16		dB	$I_C = 6\text{ mA}$ $I_C = 10\text{ mA}$
Output return loss	RL_{out}		14 23			$I_C = 6\text{ mA}$ $I_C = 10\text{ mA}$

²⁾ Test fixture losses are extracted

³⁾ Parameter measured on an application board according to Figure 1 on page 2 presenting a 50 Ω system to the device. I_{Cq} is the quiescent current, that is at small RF input power level. I_C increases as RF input power level approaches $IP_{1\text{dB}}$.

Electrical characteristics

Table 10 AC characteristics, $V_C = 3\text{ V}$, $f = 1.9\text{ GHz}$

Parameter	Symbol	Values			Unit	Note or test condition
		Min.	Typ.	Max.		
Minimum noise figure ²⁾	NF_{min}	–	1.05 1.05	–	dB	$I_C = 6\text{ mA}$ $I_C = 10\text{ mA}$ $Z_S = Z_{S,opt}$
Noise figure in 50 Ω system ³⁾	NF_{50}		1.15 1.1			$I_C = 6\text{ mA}$ $I_C = 10\text{ mA}$ $Z_S = Z_L = 50\ \Omega$
Transducer gain	$ S_{21} ^2$		17.5 19		dB	$I_C = 6\text{ mA}$ $I_C = 10\text{ mA}$
Maximum available power gain	G_{ma}		18 19.5			$I_C = 6\text{ mA}$ $I_C = 10\text{ mA}$
Input 1 dB gain compression point	IP_{1dB}		-4 -6		dBm	$I_{Cq} = 6\text{ mA}$ $I_{Cq} = 10\text{ mA}$
Input 3 rd order intercept point	IIP_3		2.5 1			$I_C = 6\text{ mA}$ $I_C = 10\text{ mA}$
Input return loss	RL_{in}		13.5 15		dB	$I_C = 6\text{ mA}$ $I_C = 10\text{ mA}$
Output return loss	RL_{out}		13.5 21			$I_C = 6\text{ mA}$ $I_C = 10\text{ mA}$

²⁾ Test fixture losses are extracted

³⁾ Parameter measured on an application board according to [Figure 1](#) on page 2 presenting a 50 Ω system to the device. I_{Cq} is the quiescent current, that is at small RF input power level. I_C increases as RF input power level approaches IP_{1dB} .

Electrical characteristics

Table 11 AC characteristics, $V_C = 3\text{ V}$, $f = 2.4\text{ GHz}$

Parameter	Symbol	Values			Unit	Note or test condition
		Min.	Typ.	Max.		
Minimum noise figure ²⁾	NF_{min}	–	1.1 1.05	–	dB	$I_C = 6\text{ mA}$ $I_C = 10\text{ mA}$ $Z_S = Z_{S,opt}$
Noise figure in 50 Ω system ³⁾	NF_{50}		1.15 1.1			$I_C = 6\text{ mA}$ $I_C = 10\text{ mA}$ $Z_S = Z_L = 50\ \Omega$
Transducer gain	$ S_{21} ^2$		17 18.5		dB	$I_C = 6\text{ mA}$ $I_C = 10\text{ mA}$
Maximum available power gain	G_{ma}		17.5 19			$I_C = 6\text{ mA}$ $I_C = 10\text{ mA}$
Input 1 dB gain compression point	IP_{1dB}		-3.5 -5.5		dBm	$I_{Cq} = 6\text{ mA}$ $I_{Cq} = 10\text{ mA}$
Input 3 rd order intercept point	IIP_3		3 1			$I_C = 6\text{ mA}$ $I_C = 10\text{ mA}$
Input return loss	RL_{in}		12.5 13.5		dB	$I_C = 6\text{ mA}$ $I_C = 10\text{ mA}$
Output return loss	RL_{out}		12.5 18			$I_C = 6\text{ mA}$ $I_C = 10\text{ mA}$

²⁾ Test fixture losses are extracted

³⁾ Parameter measured on an application board according to [Figure 1](#) on page 2 presenting a 50 Ω system to the device. I_{Cq} is the quiescent current, that is at small RF input power level. I_C increases as RF input power level approaches IP_{1dB} .

Electrical characteristics

Table 12 AC characteristics, $V_C = 3\text{ V}$, $f = 3.5\text{ GHz}$

Parameter	Symbol	Values			Unit	Note or test condition
		Min.	Typ.	Max.		
Minimum noise figure ²⁾	NF_{\min}	–	1.25 1.2	–	dB	$I_C = 6\text{ mA}$ $I_C = 10\text{ mA}$ $Z_S = Z_{S,\text{opt}}$
Noise figure in 50 Ω system ³⁾	NF_{50}		1.35 1.25			$I_C = 6\text{ mA}$ $I_C = 10\text{ mA}$ $Z_S = Z_L = 50\ \Omega$
Transducer gain	$ S_{21} ^2$		15 16.5		dB	$I_C = 6\text{ mA}$ $I_C = 10\text{ mA}$
Maximum available power gain	G_{ma}		16 17.5			$I_C = 6\text{ mA}$ $I_C = 10\text{ mA}$
Input 1 dB gain compression point	$IP_{1\text{dB}}$		-2.5 -4.5		dBm	$I_{Cq} = 6\text{ mA}$ $I_{Cq} = 10\text{ mA}$
Input 3 rd order intercept point	IIP_3		3.5 1.5			$I_C = 6\text{ mA}$ $I_C = 10\text{ mA}$
Input return loss	RL_{in}		10 10.5		dB	$I_C = 6\text{ mA}$ $I_C = 10\text{ mA}$
Output return loss	RL_{out}		10 13.5			$I_C = 6\text{ mA}$ $I_C = 10\text{ mA}$

²⁾ Test fixture losses are extracted

³⁾ Parameter measured on an application board according to Figure 1 on page 2 presenting a 50 Ω system to the device. I_{Cq} is the quiescent current, that is at small RF input power level. I_C increases as RF input power level approaches $IP_{1\text{dB}}$.

Electrical characteristics

Table 13 AC characteristics, $V_C = 3\text{ V}$, $f = 5.5\text{ GHz}$

Parameter	Symbol	Values			Unit	Note or test condition
		Min.	Typ.	Max.		
Minimum noise figure ²⁾	NF_{min}	–	1.8 1.75	–	dB	$I_C = 6\text{ mA}$ $I_C = 10\text{ mA}$ $Z_S = Z_{S,opt}$
Noise figure in 50 Ω system ³⁾	NF_{50}		1.95 1.85			$I_C = 6\text{ mA}$ $I_C = 10\text{ mA}$ $Z_S = Z_L = 50\ \Omega$
Transducer gain	$ S_{21} ^2$		12 13			$I_C = 6\text{ mA}$ $I_C = 10\text{ mA}$
Maximum available power gain	G_{ma}		14 15			$I_C = 6\text{ mA}$ $I_C = 10\text{ mA}$
Input 1 dB gain compression point	IP_{1dB}		-1 -3		dBm	$I_{Cq} = 6\text{ mA}$ $I_{Cq} = 10\text{ mA}$
Input 3 rd order intercept point	IIP_3		8.5 4			$I_C = 6\text{ mA}$ $I_C = 10\text{ mA}$
Input return loss	RL_{in}		7 8		dB	$I_C = 6\text{ mA}$ $I_C = 10\text{ mA}$
Output return loss	RL_{out}		7 8.5			$I_C = 6\text{ mA}$ $I_C = 10\text{ mA}$

²⁾ Test fixture losses are extracted

³⁾ Parameter measured on an application board according to [Figure 1](#) on page 2 presenting a 50 Ω system to the device. I_{Cq} is the quiescent current, that is at small RF input power level. I_C increases as RF input power level approaches IP_{1dB} .

5 Package information TSLP-7-1

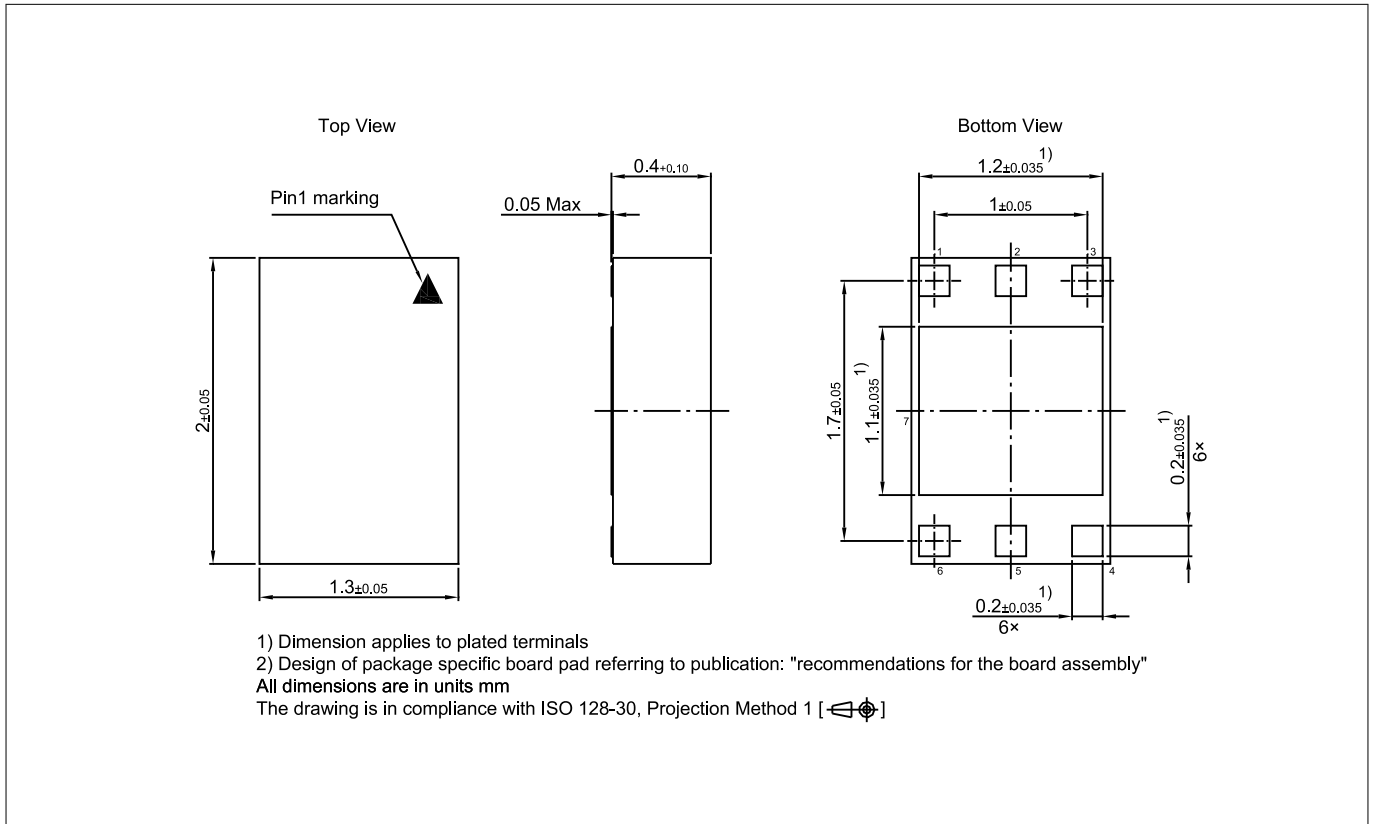

Figure 8 TSLP-7-1 package

Note: For package information including footprint, packing and assembly recommendation refer to:

<https://www.infineon.com/cms/en/product/packages/PG-TSLP/PG-TSLP-7-1>

Revision history

Revision history

Document version	Date of release	Description of changes
3.0	2018-09-26	New datasheet layout.
3.1	2021-07-14	Package outline marking corrected, link to Infineon package website added

Trademarks

All referenced product or service names and trademarks are the property of their respective owners.

Edition 2021-07-14

Published by
Infineon Technologies AG
81726 Munich, Germany

© 2021 Infineon Technologies AG
All Rights Reserved.

Do you have a question about any
aspect of this document?
Email: erratum@infineon.com

Document reference
IFX-zev1491985034409

IMPORTANT NOTICE

The information given in this document shall in no event be regarded as a guarantee of conditions or characteristics ("Beschaffheitsgarantie").

With respect to any examples, hints or any typical values stated herein and/or any information regarding the application of the product, Infineon Technologies hereby disclaims any and all warranties and liabilities of any kind, including without limitation warranties of non-infringement of intellectual property rights of any third party.

In addition, any information given in this document is subject to customer's compliance with its obligations stated in this document and any applicable legal requirements, norms and standards concerning customer's products and any use of the product of Infineon Technologies in customer's applications.

The data contained in this document is exclusively intended for technically trained staff. It is the responsibility of customer's technical departments to evaluate the suitability of the product for the intended application and the completeness of the product information given in this document with respect to such application.



WARNINGS

Due to technical requirements products may contain dangerous substances. For information on the types in question please contact your nearest Infineon Technologies office.

Except as otherwise explicitly approved by Infineon Technologies in a written document signed by authorized representatives of Infineon Technologies, Infineon Technologies' products may not be used in any applications where a failure of the product or any consequences of the use thereof can reasonably be expected to result in personal injury.

Looking for pricing, stock, or lifecycle information?

Click below to explore more details on WIN SOURCE:

-  [View BGB 741L7ESD E6327 on WIN SOURCE](#)
-  [Infineon Technologies Information](#)

Optimize Your Supply Chain with WIN SOURCE Solutions

-  Global Sourcing Solution
-  Obsolete Management
-  Cost Control Management
-  Shortage Management
-  Alternative Solution
-  Excess Inventory Management