

MMA-445933H-M5 4.4 - 5.9 GHz 2W High Efficiency Linear Power Amplifier

Features:

- 31 dB Gain
- 33 dBm P_{-1dB}
- OIP3 45 dBm
- 25.0 dBm Linear Pout @ 2.5% EVM (802.11 64QAM)
- Fully Matched Input and Output for Easy Cascade
- Internal Bias Tee
- Surface Mount, RoHS Compliant QFN 5x5mm Package

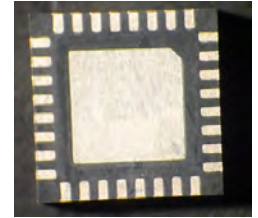

Description:

The MMA-445933H-M5 is a power amplifier with the State-of-the-Art linear power between 4.4 GHz and 5.9 GHz frequency band. Based on advanced robust HFET device technology, the linearity of this power amplifier is 25 dBm linear power at 2.5% EVM and achieves an ACPR better than -36 dBc. The modulation test pattern is 802.16x 64QAM. This linear power amplifier also has high gain. Ideal applications include the driver and the output power stage of WiMax and WLAN infrastructures and access points. It also can be used for PTP (Point-To-Point) radio applications for this band.

Typical RF Performance: $V_{d1}=7.5V$, $V_{d2}=7.5V$, $V_{g1}=-0.8V$, $V_{g2}=-0.8V$, $I_{dq1}=410mA$, $I_{dq2}=622mA$, $T_a=25\text{ }^\circ\text{C}$, $Z_0=50\text{ ohm}$

| Parameter | Units | Typical Data |
|-----------------------------------|-----------------------------|--------------|
| Frequency Range | MHz | 4400-5900 |
| Gain (Typ) | dB | 31 |
| Gain Flatness (Typ) | +/-dB | 2.5 |
| Input Return Loss (Typ) | dB | 10 |
| Output Return Loss (Typ) | dB | 10 |
| Output P1dB (Typ) | dBm | 33 |
| OIP3 (Typ) | dBm | 45 |
| Pout @ 2.5% EVM (Typ) | dBm | 25.0 |
| Operating Current Range | mA | 1050 |
| Thermal Resistance (Driver Stage) | $^\circ\text{C} / \text{W}$ | 20 |
| Thermal Resistance (Output Stage) | $^\circ\text{C} / \text{W}$ | 16 |

MMA-445933H-M5

4.4 – 5.9 GHz 2W High Efficiency
Linear Power Amplifier

Typical RF Performance: $V_{d1}=7.5V$, $V_{d2}=7.5V$, $V_{g1}=-0.8$, $V_{g2}=-0.8V$, $I_{dq1}=410mA$,
 $I_{dq2}=620mA$, $Z_0=50\text{ ohm}$, $T_a=25\text{ }^\circ\text{C}$

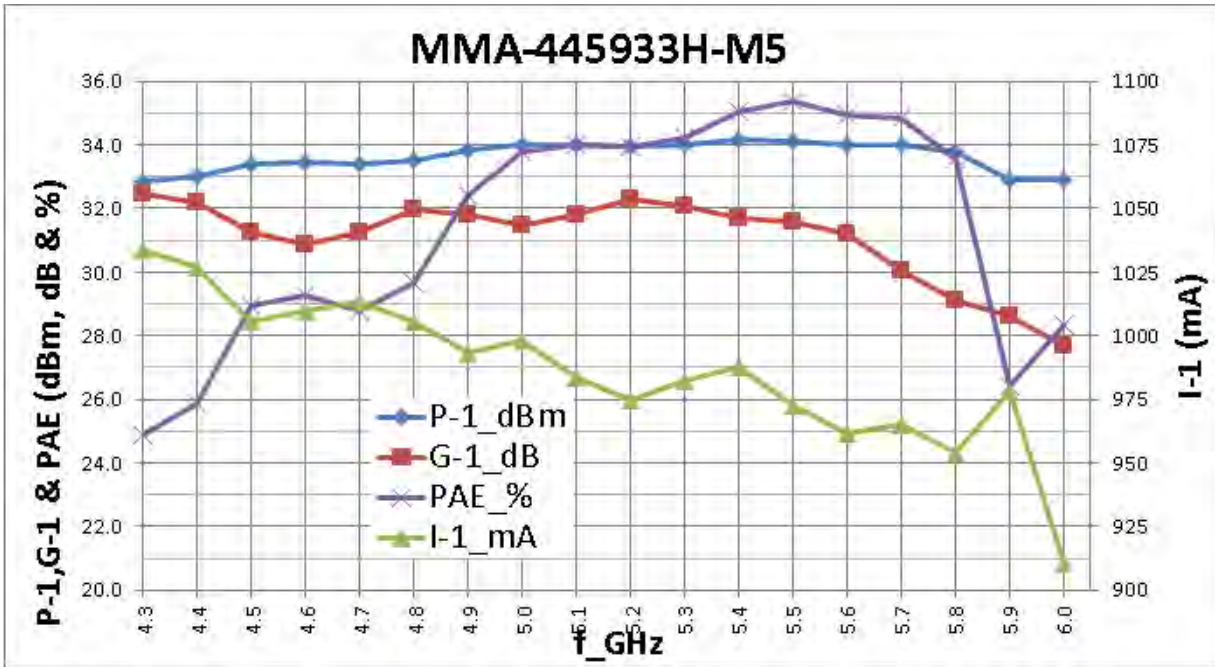

MMA-445933H-M5

4.4 – 5.9 GHz 2W High Efficiency
Linear Power Amplifier

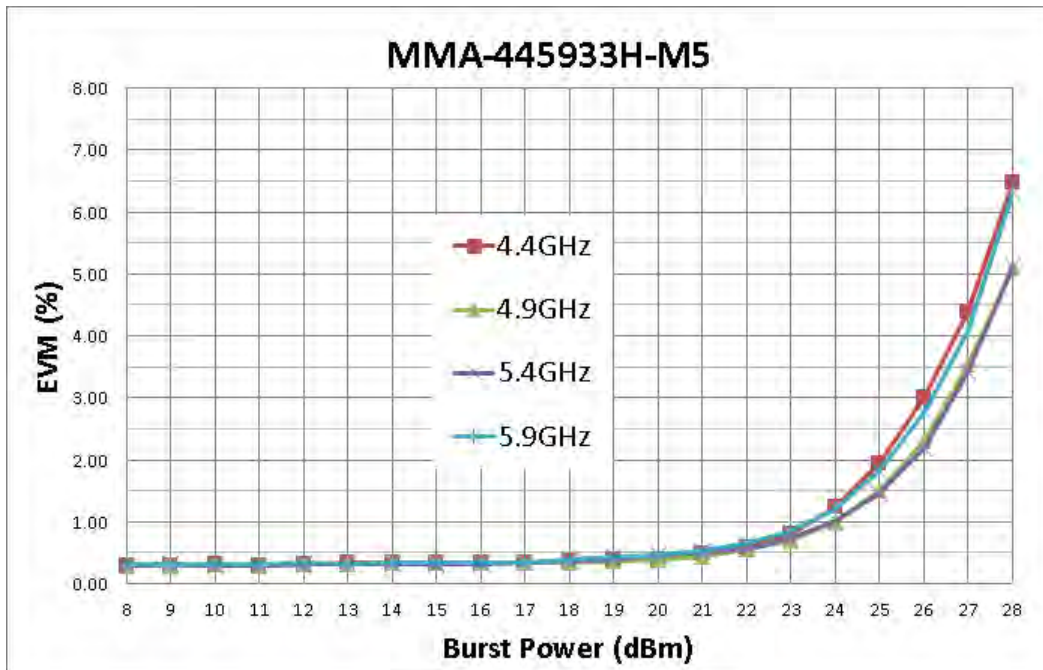

Maximum Ratings: (Ta= 25 °C)*

| SYMBOL | PARAMETERS | UNITS | ABSOLUTE MAXIMUM |
|-------------|-----------------------------------|-------|------------------|
| Vdd1 | Drain-Source Voltage Driver Stage | V | 10 |
| Vdd2 | Drain-Source Voltage Output Stage | V | 10 |
| Vgg1 | Gate-Source Voltage Driver Stage | V | -5 |
| Vgg2 | Gate-Source Voltage Output Stage | V | -5 |
| Idq1 | Drain Current Driver Stage | mA | 500 |
| Idq2 | Drain Current Output Stage | mA | 750 |
| Ig1 and Ig2 | Gate Current | mA | 10 |
| Ip | Pinch-Off Current | mA | 10 |
| Pdiss | DC Power Dissipation | W | 9.0 |
| Pin max | RF Input Power | dBm | +10 |
| Toper | Operating Temperature | °C | -40 to +85 |
| Tch | Channel Temperature | °C | 175 |
| Tstg | Storage Temperature | °C | -55 to 150 |

*Operation of this device above any one of these parameters may cause permanent damage.

Small Signal Gain and S-Parameters

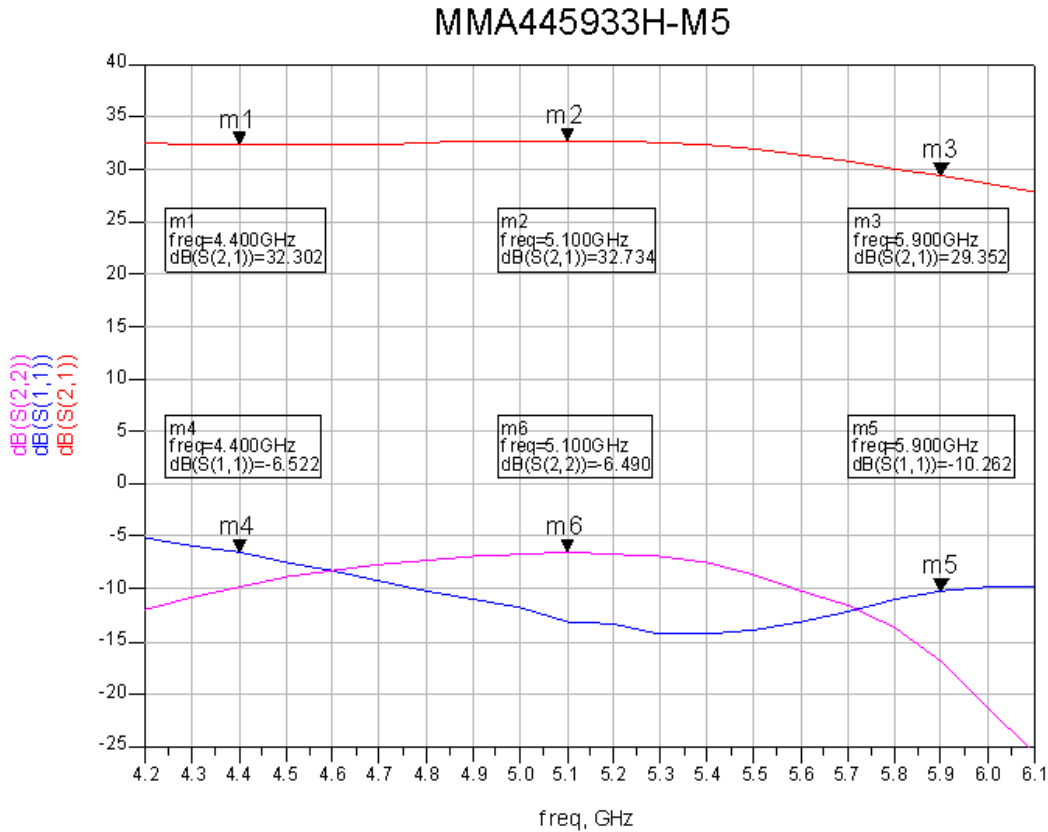

S11, S22, S21

MMA-445933H-M5

4.4 – 5.9 GHz 2W High Efficiency
Linear Power Amplifier

Mechanical Information:

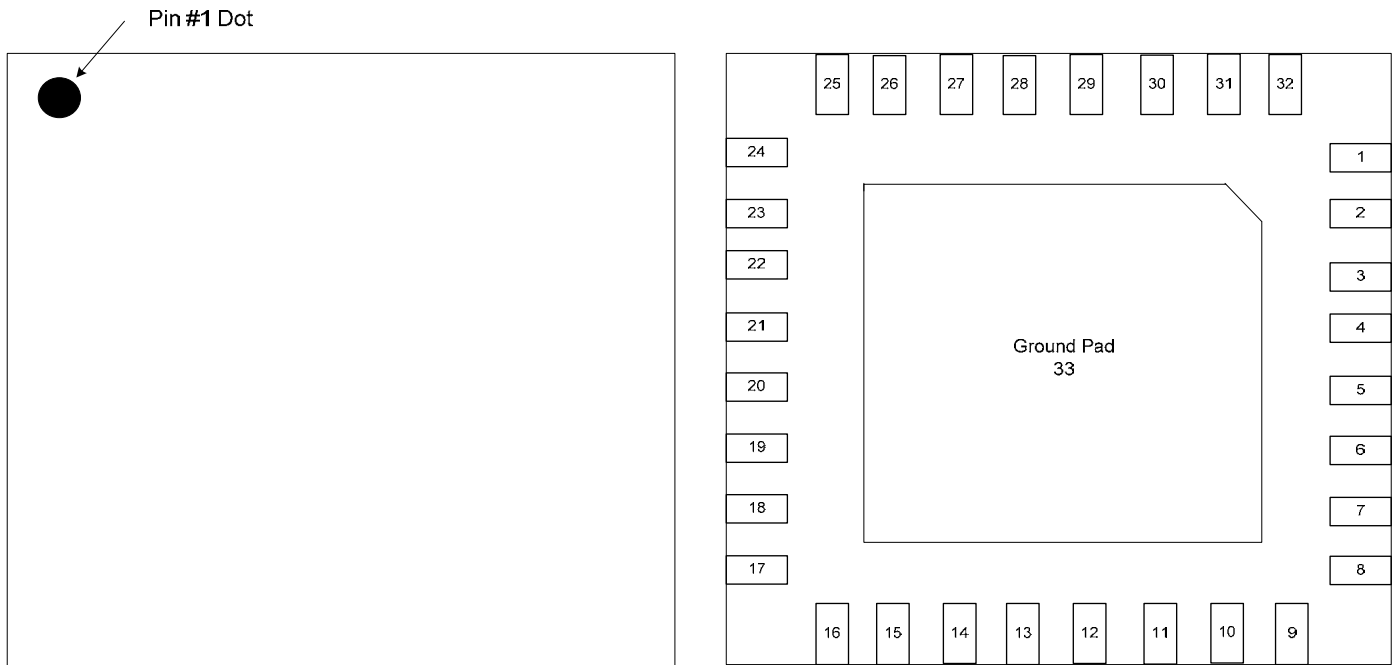

Pin Configurations:

| Pin | Descriptions |
|--------------------------------|---------------|
| 4,5 | RFin |
| 20,21 | RFout |
| 30,29 | Vgs1a,Vgs1b |
| 27 | Vgs2 |
| 11,12 | Vds1a,Vds1b |
| 14 | Vds2 |
| 1,2,32,7,8,9,16,17,18,23,24,25 | GND |
| 3,6,10,13,15,19,22,26,28,31 | No connection |

MMA-445933H-M5

4.4 – 5.9 GHz 2W High Efficiency
Linear Power Amplifier

Mechanical Information:

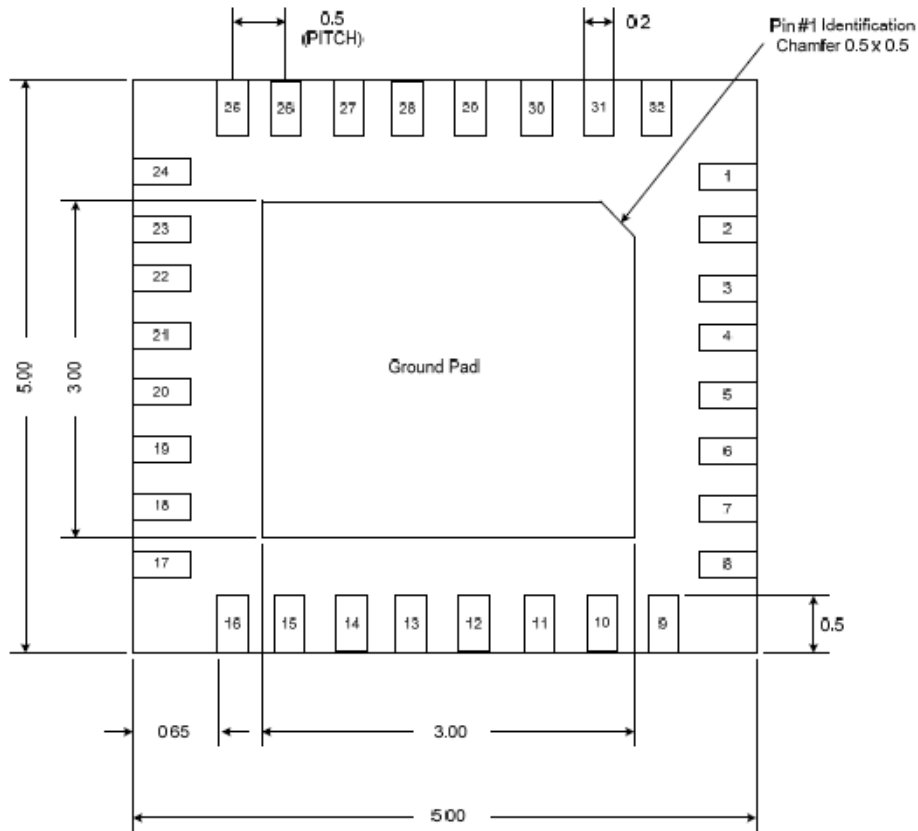

BOTTOM VIEW

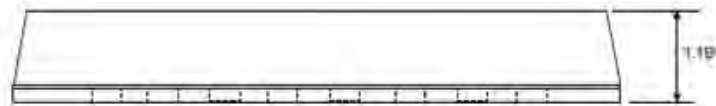

SIDE VIEW

The units are in [mm].

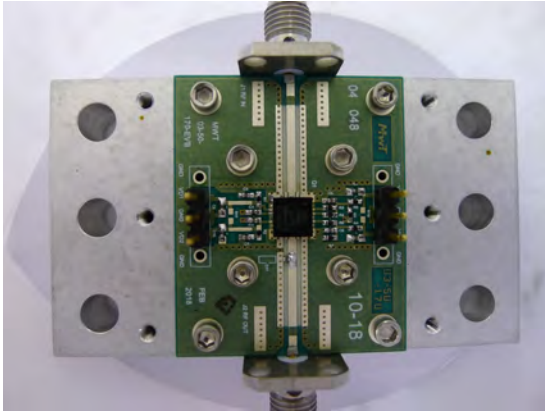

Figure 1 Evaluation board

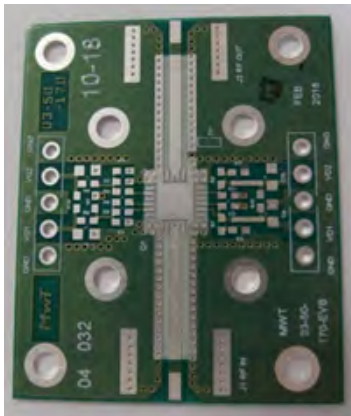

Figure 2 Hole Layout

Application Note

The evaluation board, shown in Figure 1, is fabricated with Rogers's 4003 material, 20 mil thick, 2 oz copper weight and includes four DC input connections and two RF lines. The MMA-445933H-M5 shown in the center of board is a 2 watt high gain and high linearity amplifier. The MMA-445933H-M5 is a 3 stage amplifier assembly die attach to the modified '02' package which includes four bias entries and two RF connections. The bias tees are built-in to the package. Small value bypassing capacitors are included with assembly. Proper bypassing is still required on the DC lines. The amplifier operates over a temperature range of approximately 85°C.

The PCB requires via holes with a diameter of 20 mils placed uniformly over the center pad for thermal relief and RF ground as shown in Figure 2. The via holes can be back filled with conductive epoxy for best thermal performance.

MMA-445933H-M5

4.4 – 5.9 GHz 2W High Efficiency
Linear Power Amplifier

Diagram:

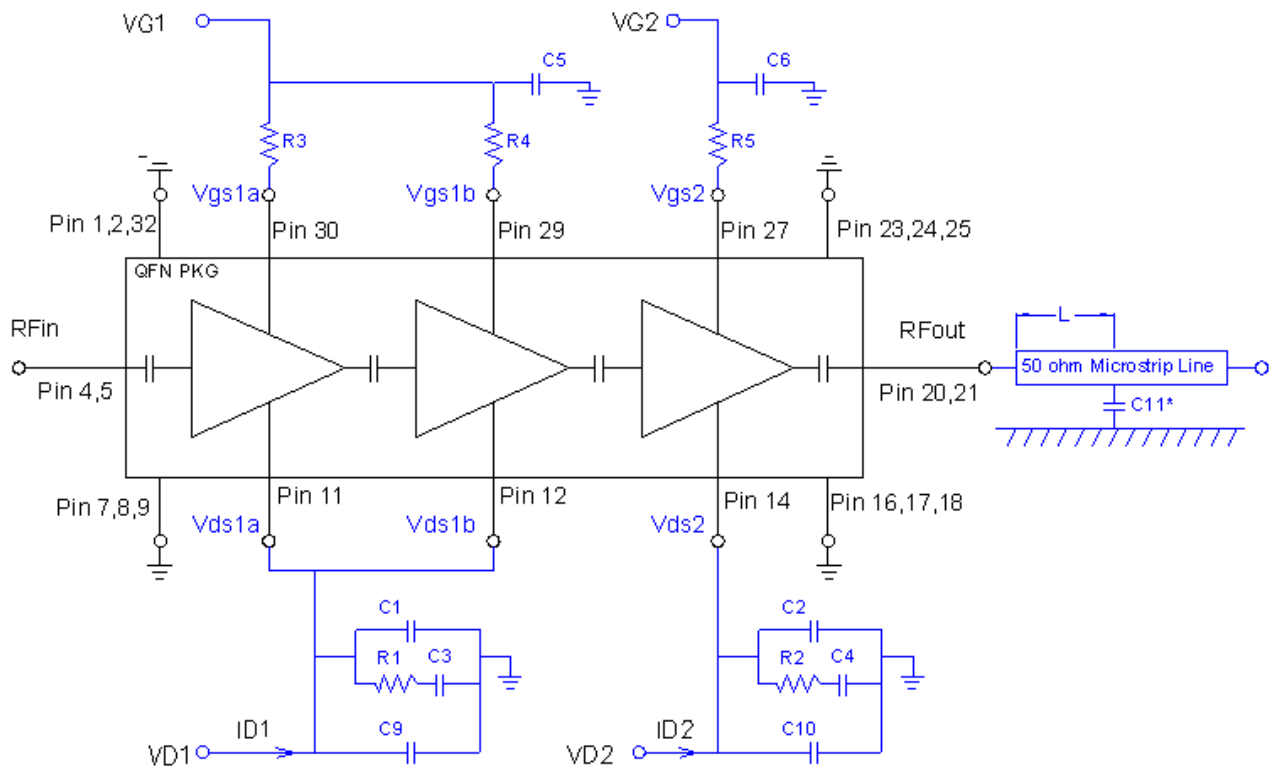

| Components | Value | |
|-------------------------------|--|--|
| R1,R2 | 50 ohm | |
| R3,R4 | 39 ohm | |
| R5 | 22 ohm | |
| C1,C2 | 100~1000 pF | |
| C3,C4,C5,C6 | 0.1 μ F | |
| C9,C10 | >0.1 μ F | |
| C11* (Option for better VSWR) | 0.15 - 0.2 pF, Distance = L | |
| | $L = \frac{0.203}{\sqrt{\epsilon_e}} \text{ (inch)}$ | |

ϵ_e is the effective dielectric constant of the 50 ohm micro-strip transmission line of the PCB circuit. For example, this length will be 0.1215 inch from the package edge to the capacitor center for 50 ohm line with Rogers RO 4003C substrate (Line width will be 0.042 inch for

MMA-445933H-M5

**4.4 – 5.9 GHz 2W High Efficiency
Linear Power Amplifier**

Contact Information

For additional information please visit www.cmlmicro.com or contact a sales office.



| Europe | America | Asia |
|---|--|--|
| <ul style="list-style-type: none">• Maldon, UK• Tel +44 (0) 1621 875500• sales@cmlmicro.com | <ul style="list-style-type: none">• Winston-Salem, NC• Tel +1 336 744 5050• us.sales@cmlmicro.com | <ul style="list-style-type: none">• Singapore• Tel +65 6288129• sg.sales@cmlmicro.com |

Although the information contained in this document is believed to be accurate, no responsibility is assumed by CML for its use. The product and product information is subject to change at any time without notice. CML has a policy of testing every product shipped using calibrated test equipment to ensure compliance with product specification.

© 2019 CML Microsystems Plc

Looking for pricing, stock, or lifecycle information?

Click below to explore more details on WIN SOURCE:

-  [View MMA-445933H-M5 on WIN SOURCE](#)
-  [CML Microcircuits Information](#)

Optimize Your Supply Chain with WIN SOURCE Solutions

-  Global Sourcing Solution
-  Obsolete Management
-  Cost Control Management
-  Shortage Management
-  Alternative Solution
-  Excess Inventory Management