



MEDIUM POWER, WIDEBAND, HIGH IP3

# Monolithic Amplifier

## PMA3-83MP+

50Ω 0.4 to 8 GHz 0.5W

### THE BIG DEAL

- High P<sub>OUT</sub>, 0.5 W to 2 GHz
- High IP3, +37.9 dBm Typ.
- Low Noise Figure, 3.1 dB Typ.
- Small 3x3 mm package
- Patent Pending

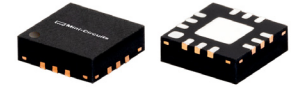

Generic photo used for illustration purposes only

CASE STYLE: DQ1225

### APPLICATIONS

- WiFi
- WLAN
- LTE/WCDMA/EDGE
- L, S and C-band Radar
- C-band Satcom

#### +RoHS Compliant

The +Suffix identifies RoHS Compliance. See our website for methodologies and qualifications

### PRODUCT OVERVIEW

The PMA3-83MP+ is a GaAs PHEMT based wideband, low noise MMIC amplifier with a unique combination of low noise, high IP3, and high output power, over a wideband making it ideal for sensitive, high-dynamic range receiver applications. This design operates on a single supply of +8V, is well matched for 50Ω and comes in a tiny, low profile package (3 x 3 mm-12 lead), accommodating dense circuit board layouts.

### KEY FEATURES

Feature	Advantages
Low noise, 3 dB Typical up to 8 GHz	Enables lower system noise figure performance.
High IP3 <ul style="list-style-type: none"> <li>• +39.5 dBm at 0.4 GHz</li> <li>• +37.9 dBm at 2 GHz</li> <li>• +39.0 dBm at 4 GHz</li> <li>• +38.6 dBm at 8 GHz</li> </ul>	Combination of low noise and high IP3 makes this MMIC amplifier ideal for use in low noise receiver front end (RFE) as it gives the user advantages of sensitivity and two-tone IM performance at both ends of the dynamic range.
V <sub>DD</sub> Operates over +5V to +8V	Allows the designer to tailor Pout and OIP3 via DC input for easier integration.
3 x 3 mm - 12-lead MCLP package	Tiny footprint saves space in dense layouts while providing low inductance, repeatable transitions, and excellent thermal contact to the PCB.
Wide bandwidth with flat gain <ul style="list-style-type: none"> <li>• ±1.5 dB over 4 to 7 GHz</li> <li>• ±2.0 dB over 0.4 to 8 GHz</li> </ul>	Enables a single amplifier to be used in many wideband applications including defense, instrumentation and more.



MEDIUM POWER, WIDEBAND, HIGH IP3

# Monolithic Amplifier

# PMA3-83MP+

Mini-Circuits

## ELECTRICAL SPECIFICATIONS<sup>1</sup> AT +25°C, 50Ω, UNLESS NOTED

Parameter	Condition (MHz)	V <sub>DD</sub> = +8V & V <sub>adj</sub> = +1.7 V			Units
		Min.	Typ.	Max.	
Frequency range		400		8000	MHz
Gain	400	19.6	21.7	23.9	dB
	2000	18.9	21.0	23.1	
	4000	17.0	18.9	20.8	
	5000	16.7	18.6	20.5	
	8000	—	17.3	—	
Input Return loss	400		13.1		dB
	2000		14.8		
	4000		8.3		
	5000		8.4		
	8000		10.4		
Output Return loss	400		9.8		dB
	2000		17.3		
	4000		13.8		
	5000		11.8		
	8000		23.6		
Output Power at 1 dB Compression (P1dB)	400		+27.2		dBm
	2000		+27.8		
	4000		+25.9		
	5000		+25.1		
	8000		+25.3		
Output IP3 (OIP3) (P <sub>OUT</sub> = +18 dBm/Tone)	400		+39.5		dBm
	2000		+37.9		
	4000		+39.0		
	5000		+35.2		
	8000		+38.6		
Noise Figure	400		3.5		dB
	2000		3.2		
	4000		3.2		
	6000		3.0		
	8000		3.3		
Device Operating Voltage (V <sub>DD</sub> )		+7.6	+8.0	+8.4	V
Device Operating Current (I <sub>DD</sub> )			144	175	mA
Current at V <sub>adj</sub> (I <sub>adj</sub> )			115		μA
Device Current Variation vs. Temperature <sup>2</sup>			-50		μA/°C
Device Current Variation vs Voltage <sup>3</sup>			0.02		mA/mV
Thermal Resistance, junction-to-ground Lead			46.3		°C/W

1. Measured on Mini-Circuits Characterization Test Board TB-PMA3-83MP+. See Characterization Test & Application Circuit (Fig. 1)

2. Device Current Variation vs. Temperature= (Current in mA at 85°C - Current in mA at -45°C)/130°C

3. Device Current Variation vs. Voltage = (Current in mA at 8.4V - Current in mA at 7.6V) / ((8.4V-7.6V)\*1000 mA/mV)

## ABSOLUTE MAXIMUM RATINGS<sup>4</sup>

Parameter	Ratings
Operating Temperature (ground lead)	-40°C to +85°C
Storage Temperature	-65°C to +150°C
Junction Temperature	+150°C
Total Power Dissipation	1.4 W
Input power (CW)	+22 dBm (5 minutes max.) +17 dBm (continuous)
DC voltage at V <sub>adj</sub>	+2.0 V
DC voltage at V <sub>DD</sub>	+9 V

4. Permanent damage may occur if any of those limits are exceeded.

Electrical maximum ratings are not intended for continuous normal operation.





MEDIUM POWER, WIDEBAND, HIGH IP3

# Monolithic Amplifier

# PMA3-83MP+

## SIMPLIFIED SCHEMATIC AND PAD DESCRIPTION

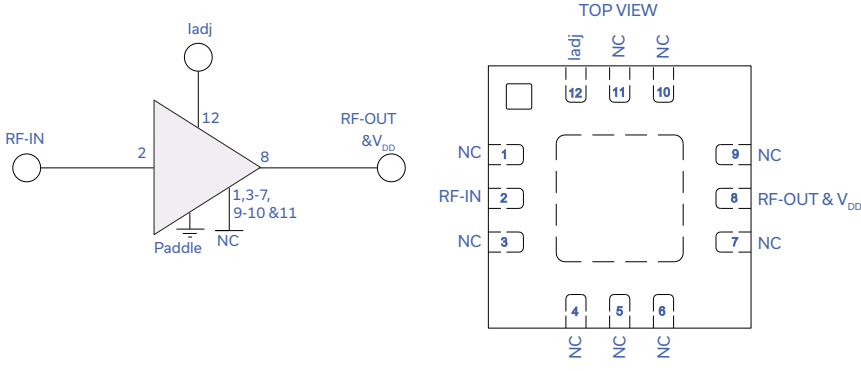

Function	Pad Number	Description (Fig 1)
RF-IN	2	Connects to RF input via C1
RF-OUT & V <sub>DD</sub>	8	Connects to RF out via C2 and connects to V <sub>DD</sub> via L1
ladj	12	Current Adjustment Pad. Connects to Vladj
No Connection	1,3-7, 9,10,11	Not used internally. Connected to ground on Test Board
Ground	Paddle	Connects to ground on Test board.

## CHARACTERIZATION TEST & APPLICATION CIRCUIT

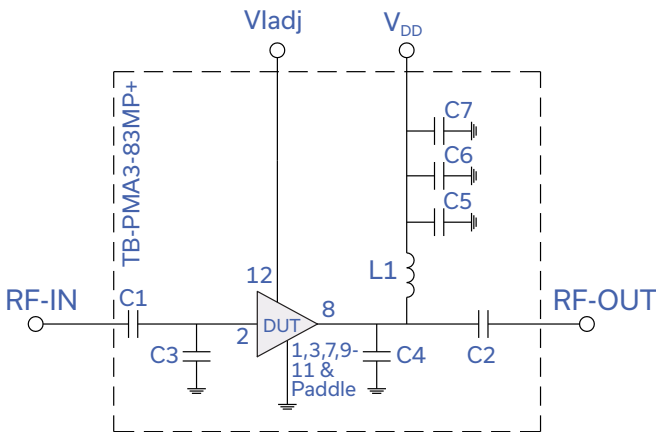

Fig 1. Application and Characterization Circuit

Note: This block diagram is used for characterization. (DUT is soldered on Mini-Circuits Characterization test board TB-PMA3-83MP+)

Gain, Return loss, Output power at 1dB compression (P1dB), Output IP3 (OIP3) and Noise Figure measured using Agilent's N5242A PNA-X microwave network analyzer.

### Conditions:

- V<sub>DD</sub> = +8V, Vladj = +1.7V
- Gain and Return Loss: P<sub>IN</sub> = -25dBm
- Output IP3 (OIP3): Two tones, spaced 1 MHz apart, 18 dBm/tone at output.

Component	Size	Value	Part Number	Manufacturer
C1	0402	100pF	GRM1555C1H101JA01D	Murata
C2	0402	100pF	GRM1555C1H101JA01D	Murata
C3	0402	0.3pF	GQM1555C2DR30WB01D	Murata
C4	0402	0.3pF	GQM1555C2DR30WB01D	Murata
C5	0402	10pF	GRM1555C1H100JA01D	Murata
C6	0402	1uF	GRM155C71A105KE11D	Murata
C7	0603	10uF	GRM188D71A106MA73J	Murata
L1	0603	33nH	0603CS-33NXJEU	Coilcraft

## PRODUCT MARKING

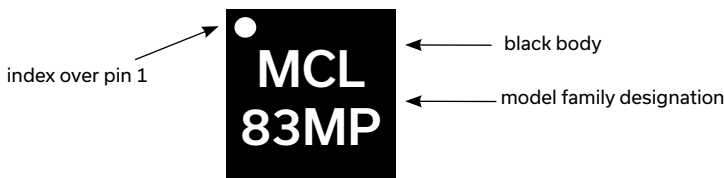

Marking may contain other features or characters for internal lot control





MEDIUM POWER, WIDEBAND, HIGH IP3

# Monolithic Amplifier

## PMA3-83MP+

Mini-Circuits

ADDITIONAL DETAILED TECHNICAL INFORMATION IS AVAILABLE ON OUR DASH BOARD. TO ACCESS [CLICK HERE](#)

Performance Data	Data Table
	Swept Graphs
	S-Parameter (S2P Files) Data Set (.zip file)
Case Style	DQ1225 Plastic package, exposed paddle, lead finish: Matt Tin
Tape & Reel	F66
Standard quantities available on reel	7" reels with 20, 50, 100, 200, 500 or 2K devices
Suggested Layout for PCB Design	PL-706
Evaluation Board	TB-PMA3-83MP+
Environmental Ratings	ENV08T1

### ESD RATING

Human Body Model (HBM): Class 1A (250V) in accordance with ANSI/ESD STM 5.1 - 2001

### MSL RATING

Moisture Sensitivity: MSL1 in accordance with IPC/JEDEC J-STD-020D

### MSL TEST FLOW CHART

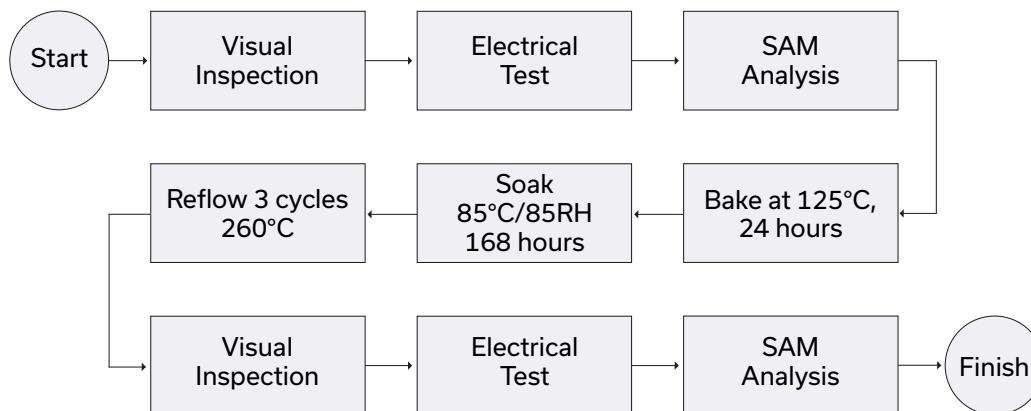



#### NOTES

- A. Performance and quality attributes and conditions not expressly stated in this specification document are intended to be excluded and do not form a part of this specification document.
- B. Electrical specifications and performance data contained in this specification document are based on Mini-Circuit's applicable established test performance criteria and measurement instructions.
- C. The parts covered by this specification document are subject to Mini-Circuits standard limited warranty and terms and conditions (collectively, "Standard Terms"); Purchasers of this part are entitled to the rights and benefits contained therein. For a full statement of the standard terms and the exclusive rights and remedies thereunder, please visit Mini-Circuits' website at [www.minicircuits.com/terms/viewterm.html](http://www.minicircuits.com/terms/viewterm.html)



## Looking for pricing, stock, or lifecycle information?

Click below to explore more details on WIN SOURCE:

-  [View PMA3-83MP+ on WIN SOURCE](#)
-  [Mini-Circuits Information](#)

## Optimize Your Supply Chain with WIN SOURCE Solutions

-  Global Sourcing Solution
-  Obsolete Management
-  Cost Control Management
-  Shortage Management
-  Alternative Solution
-  Excess Inventory Management