

NEO-6

u-blox 6 GPS Modules

Data Sheet

Abstract

Technical data sheet describing the cost effective, high-performance u-blox 6 based NEO-6 series of GPS modules, that brings the high performance of the u-blox 6 positioning engine to the miniature NEO form factor.

These receivers combine a high level of integration capability with flexible connectivity options in a small package. This makes them perfectly suited for mass-market end products with strict size and cost requirements.



16.0 x 12.2 x 2.4 mm

Document Information

Title	NEO-6
Subtitle	u-blox 6 GPS Modules
Document type	Data Sheet
Document number	GPS.G6-HW-09005-E

Document status
Document status information

Objective Specification	This document contains target values. Revised and supplementary data will be published later.
Advance Information	This document contains data based on early testing. Revised and supplementary data will be published later.
Preliminary	This document contains data from product verification. Revised and supplementary data may be published later.
Released	This document contains the final product specification.

This document applies to the following products:

Name	Type number	ROM/FLASH version	PCN reference
NEO-6G	NEO-6G-0-001	ROM7.03	UBX-TN-11047-1
NEO-6Q	NEO-6Q-0-001	ROM7.03	UBX-TN-11047-1
NEO-6M	NEO-6M-0-001	ROM7.03	UBX-TN-11047-1
NEO-6P	NEO-6P-0-000	ROM6.02	N/A
NEO-6V	NEO-6V-0-000	ROM7.03	N/A
NEO-6T	NEO-6T-0-000	ROM7.03	N/A

This document and the use of any information contained therein, is subject to the acceptance of the u-blox terms and conditions. They can be downloaded from www.u-blox.com.

u-blox makes no warranties based on the accuracy or completeness of the contents of this document and reserves the right to make changes to specifications and product descriptions at any time without notice. Reproduction, use or disclosure to third parties without express permission is strictly prohibited. Copyright © 2011, u-blox AG.

u-blox® is a registered trademark of u-blox Holding AG in the EU and other countries. ARM® is the registered trademark of ARM Limited in the EU and other countries.



Contents

Contents.....	3
1 Functional description.....	5
1.1 Overview	5
1.2 Product features	5
1.3 GPS performance.....	6
1.4 Block diagram.....	7
1.5 Assisted GPS (A-GPS).....	7
1.6 AssistNow Autonomous	7
1.7 Precision Timing.....	8
1.7.1 Time mode	8
1.7.2 Timepulse and frequency reference	8
1.7.3 Time mark	8
1.8 Raw data	8
1.9 Automotive Dead Reckoning	8
1.10 Precise Point Positioning.....	9
1.11 Oscillators	9
1.12 Protocols and interfaces	9
1.12.1 UART.....	9
1.12.2 USB	9
1.12.3 Serial Peripheral Interface (SPI).....	9
1.12.4 Display Data Channel (DDC)	10
1.13 Antenna.....	10
1.14 Power Management	10
1.14.1 Maximum Performance Mode	10
1.14.2 Eco Mode.....	10
1.14.3 Power Save Mode	11
1.15 Configuration	11
1.15.1 Boot-time configuration	11
1.16 Design-in	11
2 Pin Definition.....	12
2.1 Pin assignment	12
3 Electrical specifications	14
3.1 Absolute maximum ratings	14
3.2 Operating conditions	15
3.3 Indicative power requirements.....	15
3.4 SPI timing diagrams	16
3.4.1 Timing recommendations.....	16
4 Mechanical specifications	17

5	Qualification and certification	18
5.1	Reliability tests	18
5.2	Approvals	18
6	Product handling & soldering	19
6.1	Packaging	19
6.1.1	Reels	19
6.1.1	Tapes	20
6.2	Moisture Sensitivity Levels	21
6.3	Reflow soldering	21
6.4	ESD handling precautions	21
7	Default settings	22
8	Labeling and ordering information	23
8.1	Product labeling	23
8.2	Explanation of codes	23
8.3	Ordering information	24
	Related documents	24
	Revision history	24
	Contact	25

1 Functional description

1.1 Overview

The NEO-6 module series is a family of stand-alone GPS receivers featuring the high performance u-blox 6 positioning engine. These flexible and cost effective receivers offer numerous connectivity options in a miniature 16 x 12.2 x 2.4 mm package. Their compact architecture and power and memory options make NEO-6 modules ideal for battery operated mobile devices with very strict cost and space constraints.

The 50-channel u-blox 6 positioning engine boasts a Time-To-First-Fix (TTFF) of under 1 second. The dedicated acquisition engine, with 2 million correlators, is capable of massive parallel time/frequency space searches, enabling it to find satellites instantly. Innovative design and technology suppresses jamming sources and mitigates multipath effects, giving NEO-6 GPS receivers excellent navigation performance even in the most challenging environments.

1.2 Product features

Model	Type					Supply		Interfaces				Features						
	GPS	PPP	Timing	Raw Data	Dead Reckoning	1.75 V - 2.0 V	2.7 V - 3.6 V	UART	USB	SPI	DDC (I ² C compliant)	Programmable (Flash) FW update	TCXO	RTC crystal	Antenna supply and supervisor	Configuration pins	Timepulse	External interrupt/Wakeup
NEO-6G	●					●		●	●	●	●		●	●	○	3	1	●
NEO-6Q	●						●	●	●	●	●		●	●	○	3	1	●
NEO-6M	●						●	●	●	●	●			●	○	3	1	●
NEO-6P	●	●		●			●	●	●	●	●			●	○	3	1	●
NEO-6V	●				●		●	●	●	●	●			●	○	3	1	●
NEO-6T	●		●	●			●	●	●	●	●		●	●	○	3	1	●

○ = Requires external components and integration on application processor

Table 1: Features of the NEO-6 Series



All NEO-6 modules are based on GPS chips qualified according to AEC-Q100. See Chapter 5.1 for further information.

1.3 GPS performance

Parameter	Specification			
Receiver type	50 Channels GPS L1 frequency, C/A Code SBAS: WAAS, EGNOS, MSAS			
Time-To-First-Fix ¹		NEO-6G/Q/T	NEO-6M/V	NEO-6P
	Cold Start ²	26 s	27 s	32 s
	Warm Start ²	26 s	27 s	32 s
	Hot Start ²	1 s	1 s	1 s
	Aided Starts ³	1 s	<3 s	<3 s
Sensitivity ⁴		NEO-6G/Q/T	NEO-6M/V	NEO-6P
	Tracking & Navigation	-162 dBm	-161 dBm	-160 dBm
	Reacquisition ⁵	-160 dBm	-160 dBm	-160 dBm
	Cold Start (without aiding)	-148 dBm	-147 dBm	-146 dBm
	Hot Start	-157 dBm	-156 dBm	-155 dBm
Maximum Navigation update rate		NEO-6G/Q/M/T	NEO-6P/V	
		5Hz	1 Hz	
Horizontal position accuracy ⁶	GPS	2.5 m		
	SBAS	2.0 m		
	SBAS + PPP ⁷	< 1 m (2D, R50) ⁸		
	SBAS + PPP ⁷	< 2 m (3D, R50) ⁸		
Configurable Timepulse frequency range		NEO-6G/Q/M/P/V	NEO-6T	
		0.25 Hz to 1 kHz	0.25 Hz to 10 MHz	
Accuracy for Timepulse signal	RMS	30 ns		
	99%	<60 ns		
	Granularity	21 ns		
	Compensated ⁹	15 ns		
Velocity accuracy ⁶		0.1 m/s		
Heading accuracy ⁶		0.5 degrees		
Operational Limits	Dynamics	≤ 4 g		
	Altitude ¹⁰	50,000 m		
	Velocity ¹⁰	500 m/s		

Table 2: NEO-6 GPS performance

¹ All satellites at -130 dBm

² Without aiding

³ Dependent on aiding data connection speed and latency

⁴ Demonstrated with a good active antenna

⁵ For an outage duration ≤10s

⁶ CEP, 50%, 24 hours static, -130dBm, SEP: <3.5m

⁷ NEO-6P only

⁸ Demonstrated under following conditions: 24 hours, stationary, first 600 seconds of data discarded. HDOP < 1.5 during measurement period, strong signals. Continuous availability of valid SBAS correction data during full test period.

⁹ Quantization error information can be used with NEO-6T to compensate the granularity related error of the timepulse signal

¹⁰ Assuming Airborne <4g platform

1.4 Block diagram

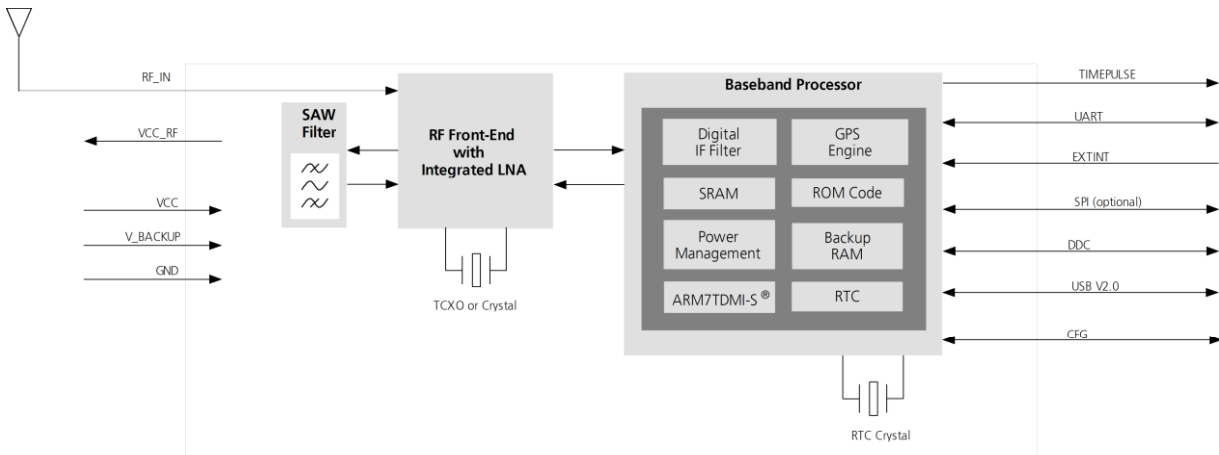

Figure 1: Block diagram (For available options refer to the product features table in section 1.2).

1.5 Assisted GPS (A-GPS)

Supply of aiding information like ephemeris, almanac, rough last position and time and satellite status and an optional time synchronization signal will reduce time to first fix significantly and improve the acquisition sensitivity. All NEO-6 modules support the u-blox AssistNow Online and AssistNow Offline A-GPS services¹¹ and are OMA SUPL compliant.

1.6 AssistNow Autonomous

AssistNow Autonomous provides functionality similar to Assisted-GPS without the need for a host or external network connection. Based on previously broadcast satellite ephemeris data downloaded to and stored by the GPS receiver, AssistNow Autonomous automatically generates accurate satellite orbital data ("AssistNow Autonomous data") that is usable for future GPS position fixes. AssistNow Autonomous data is reliable for up to 3 days after initial capture.

u-blox' AssistNow Autonomous benefits are:

- Faster position fix
- No connectivity required
- Complementary with AssistNow Online and Offline services
- No integration effort, calculations are done in the background



For more details see the u-blox 6 Receiver Description including Protocol Specification [2].

¹¹ AssistNow Offline requires external memory.

1.7 Precision Timing

1.7.1 Time mode

NEO-6T provides a special Time Mode to provide higher timing accuracy. The NEO-6T is designed for use with stationary antenna setups. The Time Mode features three different settings described in Table 3: Disabled, Survey-In and Fixed Mode. For optimal performance entering the position of the antenna (when known) is recommended as potential source of errors will be reduced.

Time Mode Settings	Description
Disabled	Standard PVT operation
Survey-In	The GPS receiver computes the average position over an extended time period until a predefined maximum standard deviation has been reached. Afterwards the receiver will be automatically set to Fixed Mode and the timing features will be activated.
Fixed Mode	<p>In this mode, a fixed 3D position and known standard deviation is assumed and the timing features are activated. Fixed Mode can either be activated directly by feeding pre-defined position coordinates (ECEF - Earth Center Earth Fixed format) or by performing a Survey-In.</p> <p>In Fixed mode, the timing errors in the TIMEPULSE signal which otherwise result from positioning errors are eliminated. Single-satellite operation is supported. For details, please refer to the u-blox 6 Receiver Description including Protocol Specification [2].</p>

Table 3: Time mode settings

1.7.2 Timepulse and frequency reference

NEO-6T comes with a timepulse output which can be configured from 0.25 Hz up to 10 MHz. The timepulse can either be used for time synchronization (i.e. 1 pulse per second) or as a reference frequency in the MHz range. A timepulse in the MHz range provides excellent long-term frequency accuracy and stability.

1.7.3 Time mark

NEO-6T can be used for precise time measurements with sub-microsecond resolution using the external interrupt (EXTINT0). Rising and falling edges of these signals are time-stamped to the GPS or UTC time and counted. The Time Mark functionality can be enabled with the UBX-CFG-TM2 message

For details, please refer to the u-blox 6 Receiver Description including Protocol Specification [2].

1.8 Raw data

Raw data output is supported at an update rate of 5 Hz on the NEO-6T and NEO-6P. The UBX-RXM-RAW message includes carrier phase with half-cycle ambiguity resolved, code phase and Doppler measurements, which can be used in external applications that offer precision positioning, real-time kinematics (RTK) and attitude sensing.

1.9 Automotive Dead Reckoning

Automotive Dead Reckoning (ADR) is u-blox' industry proven off-the-shelf Dead Reckoning solution for tier-one automotive customers. u-blox' ADR solution combines GPS and sensor digital data using a tightly coupled Kalman filter. This improves position accuracy during periods of no or degraded GPS signal.

The NEO-6V provides ADR functionality over its software sensor interface. A variety of sensors (such as wheel ticks and gyroscope) are supported, with the sensor data received via UBX messages from the application processor. This allows for easy integration and a simple hardware interface, lowering costs. By using digital sensor data available on the vehicle bus, hardware costs are minimized since no extra sensors are required for Dead Reckoning functionality. ADR is designed for simple integration and easy configuration of different sensor options (e.g. with or without gyroscope) and vehicle variants, and is completely self-calibrating.

For more details contact the u-blox support representative nearest you to receive dedicated u-blox 6 Receiver Description Including Protocol Specification [3].

1.10 Precise Point Positioning

u-blox' industry proven PPP algorithm provides extremely high levels of position accuracy in static and slow moving applications, and makes the NEO-6P an ideal solution for a variety of high precision applications such as surveying, mapping, marine, agriculture or leisure activities.

Ionospheric corrections such as those received from local SBAS¹² geostationary satellites (WAAS, EGNOS, MSAS) or from GPS enable the highest positioning accuracy with the PPP algorithm. The maximum improvement of positioning accuracy is reached with PPP+SBAS and can only be expected in an environment with unobstructed sky view during a period in the order of minutes.

1.11 Oscillators

NEO-6 GPS modules are available in Crystal and TCXO versions. The TCXO allows accelerated weak signal acquisition, enabling faster start and reacquisition times.

1.12 Protocols and interfaces

Protocol	Type
NMEA	Input/output, ASCII, 0183, 2.3 (compatible to 3.0)
UBX	Input/output, binary, u-blox proprietary
RTCM	Input, 2.3

Table 4: Available protocols

All listed protocols are available on UART, USB, and DDC. For specification of the various protocols see the u-blox 6 Receiver Description including Protocol Specification [2].

1.12.1 UART

NEO-6 modules include one configurable UART interface for serial communication (for information about configuration see section 1.15).

1.12.2 USB

NEO-6 modules provide a USB version 2.0 FS (Full Speed, 12Mbit/s) interface as an alternative to the UART. The pull-up resistor on USB_DP is integrated to signal a full-speed device to the host. The VDDUSB pin supplies the USB interface. u-blox provides a Microsoft® certified USB driver for Windows XP, Windows Vista and Windows 7 operating systems.

1.12.3 Serial Peripheral Interface (SPI)

The SPI interface allows for the connection of external devices with a serial interface, e.g. serial flash to save configuration and AssistNow Offline A-GPS data or to interface to a host CPU. The interface can be operated in master or slave mode. In master mode, one chip select signal is available to select external slaves. In slave mode a single chip select signal enables communication with the host.





The maximum bandwidth is 100kbit/s.

¹² Satellite Based Augmentation System

1.12.4 Display Data Channel (DDC)

The I²C compatible DDC interface can be used either to access external devices with a serial interface EEPROM or to interface with a host CPU. It is capable of master and slave operation. The DDC interface is I²C Standard Mode compliant. For timing parameters consult the I²C standard.

-  The DDC Interface supports serial communication with u-blox wireless modules. See the specification of the applicable wireless module to confirm compatibility.
-  The maximum bandwidth is 100kbit/s.

1.12.4.1 External serial EEPROM

NEO-6 modules allow an optional external serial EEPROM to be connected to the DDC interface. This can be used to store Configurations permanently.

-  For more information see the LEA-6/NEO-6/MAX-6 Hardware Integration Manual [1].

 **Use caution when implementing since forward compatibility is not guaranteed.**

1.13 Antenna

NEO-6 modules are designed for use with passive and active¹³ antennas.

Parameter	Specification	
Antenna Type	Passive and active antenna	
Active Antenna Recommendations	Minimum gain	15 dB (to compensate signal loss in RF cable)
	Maximum gain	50 dB
	Maximum noise figure	1.5 dB

Table 5: Antenna Specifications for all NEO-6 modules

1.14 Power Management

u-blox receivers support different power modes. These modes represent strategies of how to control the acquisition and tracking engines in order to achieve either the best possible performance or good performance with reduced power consumption.

-  For more information about power management strategies, see the u-blox 6 Receiver Description including Protocol Specification [2].

1.14.1 Maximum Performance Mode

During a Cold start, a receiver in Maximum Performance Mode continuously deploys the acquisition engine to search for all satellites. Once the receiver has a position fix (or if pre-positioning information is available), the acquisition engine continues to be used to search for all visible satellites that are not being tracked.

1.14.2 Eco Mode

During a Cold start, a receiver in Eco Mode works exactly as in Maximum Performance Mode. Once a position can be calculated and a sufficient number of satellites are being tracked, the acquisition engine is powered off resulting in significant power savings. The tracking engine continuously tracks acquired satellites and acquires other available or emerging satellites.

-  Note that even if the acquisition engine is powered off, satellites continue to be acquired.

¹³ For information on using active antennas with NEO-6 modules, see the LEA-6/NEO-6 Hardware Integration Manual [1].

1.14.3 Power Save Mode

Power Save Mode (PSM) allows a reduction in system power consumption by selectively switching parts of the receiver on and off.



Power Save mode is not available with NEO-6P, NEO-6T and NEO-6V.

1.15 Configuration

1.15.1 Boot-time configuration

NEO-6 modules provide configuration pins for boot-time configuration. These become effective immediately after start-up. Once the module has started, the configuration settings can be modified with UBX configuration messages. The modified settings remain effective until power-down or reset. If these settings have been stored in battery-backup RAM, then the modified configuration will be retained, as long as the backup battery supply is not interrupted.

NEO-6 modules include both **CFG_COM0** and **CFG_COM1** pins and can be configured as seen in Table 6. Default settings in bold.

CFG_COM1	CFG_COM0	Protocol	Messages	UARTBaud rate	USB power
1	1	NMEA	GSV, RMC, GSA, GGA, GLL, VTG, TXT	9600	BUS Powered
1	0	NMEA	GSV, RMC, GSA, GGA, GLL, VTG, TXT	38400	Self Powered
0	1	NMEA	GSV ¹⁴ , RMC, GSA, GGA, VTG, TXT	4800	BUS Powered
0	0	UBX	NAV-SOL, NAV-STATUS, NAV-SVINFORM, NAV-CLOCK, INF, MON-EXCEPT, AID-ALPSERV	57600	BUS Powered

Table 6: Supported COM settings

NEO-6 modules include a **CFG_GPS0** pin, which enables the boot-time configuration of the power mode. These settings are described in Table 7. Default settings in bold.

CFG_GPS0	Power Mode
0	Eco Mode
1	Maximum Performance Mode

Table 7: Supported CFG_GPS0 settings



Static activation of the **CFG_COM** and **CFG_GPS** pins is not compatible with use of the SPI interface.

1.16 Design-in

In order to obtain the necessary information to conduct a proper design-in, u-blox strongly recommends consulting the LEA-6/NEO-6/MAX-6 Hardware Integration Manual [1].

¹⁴ Every 5th fix.

2 Pin Definition

2.1 Pin assignment

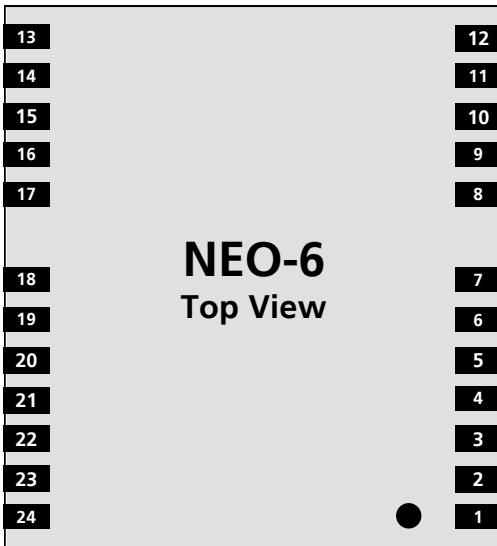

Figure 2 Pin Assignment

No	Module	Name	I/O	Description
1	All	Reserved	I	Reserved
2	All	SS_N	I	SPI Slave Select
3	All	TIMEPULSE	O	Timepulse (1PPS)
4	All	EXTINT0	I	External Interrupt Pin
5	All	USB_DM	I/O	USB Data
6	All	USB_DP	I/O	USB Data
7	All	VDDUSB	I	USB Supply
8	All	Reserved		See Hardware Integration Manual Pin 8 and 9 must be connected together.
9	All	VCC_RF	O	Output Voltage RF section Pin 8 and 9 must be connected together.
10	All	GND	I	Ground
11	All	RF_IN	I	GPS signal input
12	All	GND	I	Ground
13	All	GND	I	Ground
14	All	MOSI/CFG_COM0	O/I	SPI MOSI / Configuration Pin. Leave open if not used.
15	All	MISO/CFG_COM1	I	SPI MISO / Configuration Pin. Leave open if not used.
16	All	CFG_GPS0/SCK	I	Power Mode Configuration Pin / SPI Clock. Leave open if not used.
17	All	Reserved	I	Reserved
18	All	SDA2	I/O	DDC Data
19	All	SCL2	I/O	DDC Clock
20	All	TxD1	O	Serial Port 1
21	All	RxD1	I	Serial Port 1

No	Module	Name	I/O	Description
22	All	V_BCKP	I	Backup voltage supply
23	All	VCC	I	Supply voltage
24	All	GND	I	Ground

Table 8: Pinout

Pins designated Reserved should not be used. For more information about Pinouts see the LEA-6/NEO-6/MAX-6 Hardware Integration Manual [1].

3 Electrical specifications

3.1 Absolute maximum ratings

Parameter	Symbol	Module	Min	Max	Units	Condition
Power supply voltage	VCC	NEO-6G	-0.5	2.0	V	
		NEO-6Q, 6M, 6P, 6V, 6T	-0.5	3.6	V	
Backup battery voltage	V_BCKP	All	-0.5	3.6	V	
USB supply voltage	VDDUSB	All	-0.5	3.6	V	
Input pin voltage	Vin	All	-0.5	3.6	V	
	Vin_usb	All	-0.5	VDDU SB	V	
DC current through any digital I/O pin (except supplies)	Ipin			10	mA	
VCC_RF output current	ICC_RF	All		100	mA	
Input power at RF_IN	Prfin	NEO-6Q, 6M, 6G, 6V, 6T		15	dBm	source impedance = 50Ω, continuous wave
		NEO-6P		-5	dBm	
Storage temperature	Tstg	All	-40	85	°C	

Table 9: Absolute maximum ratings



GPS receivers are Electrostatic Sensitive Devices (ESD) and require special precautions when handling. For more information see chapter 6.4.



Stressing the device beyond the “Absolute Maximum Ratings” may cause permanent damage. These are stress ratings only. The product is not protected against overvoltage or reversed voltages. If necessary, voltage spikes exceeding the power supply voltage specification, given in table above, must be limited to values within the specified boundaries by using appropriate protection diodes. For more information see the *LEA-6/NEO-6/MAX-6 Hardware Integration Manual* [1].

3.2 Operating conditions



All specifications are at an ambient temperature of 25°C.

Parameter	Symbol	Module	Min	Typ	Max	Units	Condition
Power supply voltage	VCC	NEO-6G	1.75	1.8	1.95	V	
		NEO-6Q/M	2.7	3.0	3.6	V	
		NEO-6P/V/T					
Supply voltage USB	VDDUSB	All	3.0	3.3	3.6	V	
Backup battery voltage	V_BCKP	All	1.4		3.6	V	
Backup battery current	I_BCKP	All		22		µA	V_BCKP = 1.8 V, VCC = 0V
Input pin voltage range	Vin	All	0		VCC	V	
Digital IO Pin Low level input voltage	Vil	All	0		0.2*VCC	V	
Digital IO Pin High level input voltage	Vih	All	0.7*VCC		VCC	V	
Digital IO Pin Low level output voltage	Vol	All			0.4	V	Iol=4mA
Digital IO Pin High level output voltage	Voh	All	VCC -0.4			V	Ioh=4mA
USB_DM, USB_DP	VinU	All	Compatible with USB with 22 Ohms series resistance				
VCC_RF voltage	VCC_RF	All		VCC-0.1		V	
VCC_RF output current	ICC_RF	All			50	mA	
Antenna gain	Gant	All			50	dB	
Receiver Chain Noise Figure	NFtot	All		3.0		dB	
Operating temperature	Topr	All	-40		85	°C	

Table 10: Operating conditions



Operation beyond the specified operating conditions can affect device reliability.

3.3 Indicative power requirements

Table 11 lists examples of the total system supply current for a possible application.

Parameter	Symbol	Module	Min	Typ	Max	Units	Condition
Max. supply current ¹⁵	Iccp	All			67	mA	VCC = 3.6 V ¹⁶ / 1.95 V ¹⁷
		Icc Acquisition	All	47 ¹⁹		mA	
		Icc Tracking (Max Performance mode)	NEO-6G/Q/T	40 ²⁰		mA	
Average supply current ¹⁸		NEO-6M/P/V	NEO-6M/P/V	39 ²⁰		mA	VCC = 3.0 V ¹⁶ / 1.8 V ¹⁷
			NEO-6G/Q/T	38 ²⁰		mA	
		NEO-6M	NEO-6M/P/V	37 ²⁰		mA	
			NEO-6G/Q	12 ²⁰		mA	
		NEO-6M	11 ²⁰		mA		

Table 11: Indicative power requirements



Values in Table 11 are provided for customer information only as an example of typical power requirements. Values are characterized on samples, actual power requirements can vary depending on FW version used, external circuitry, number of SVs tracked, signal strength, type of start as well as time, duration and conditions of test.

¹⁵ Use this figure to dimension maximum current capability of power supply. Measurement of this parameter with 1 Hz bandwidth.

¹⁶ NEO-6Q, NEO-6M, NEO-6P, NEO-6V, NEO-6T

¹⁷ NEO-6G

¹⁸ Use this figure to determine required battery capacity.

¹⁹ >8 SVs in view, CNo >40 dBHz, current average of 30 sec after cold start.

²⁰ With strong signals, all orbits available. For Cold Starts typical 12 min after first fix. For Hot Starts typical 15 s after first fix.

3.4 SPI timing diagrams

In order to avoid a faulty usage of the SPI, the user needs to comply with certain timing conditions. The following signals need to be considered for timing constraints:

Symbol	Description
SS_N	Slave Select signal
SCK	Slave Clock signal

Table 12: Symbol description

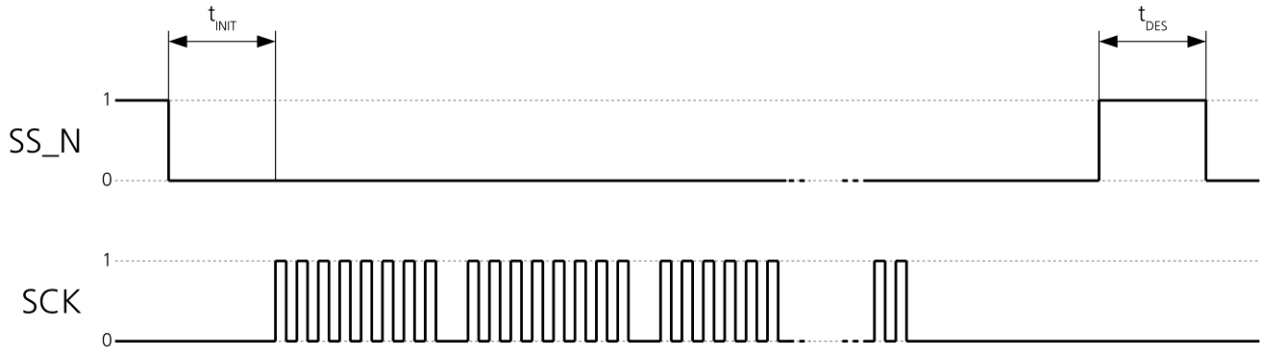

Figure 3: SPI timing diagram

3.4.1 Timing recommendations

Parameter	Description	Recommendation
t_{INIT}	Initialization Time	500 μ s
t_{DES}	Deselect Time	1 ms
Bitrate		100 kbit/s

Table 13: SPI timing recommendations



The values in the above table result from the requirement of an error-free transmission. By allowing just a few errors, the byte rate could be increased considerably. These timings – and therefore the byte rate – could also be improved by disabling other interfaces, e.g. the UART.



The maximum bandwidth is 100 kbit/s²¹.

²¹ This is a theoretical maximum, the protocol overhead is not considered.

4 Mechanical specifications

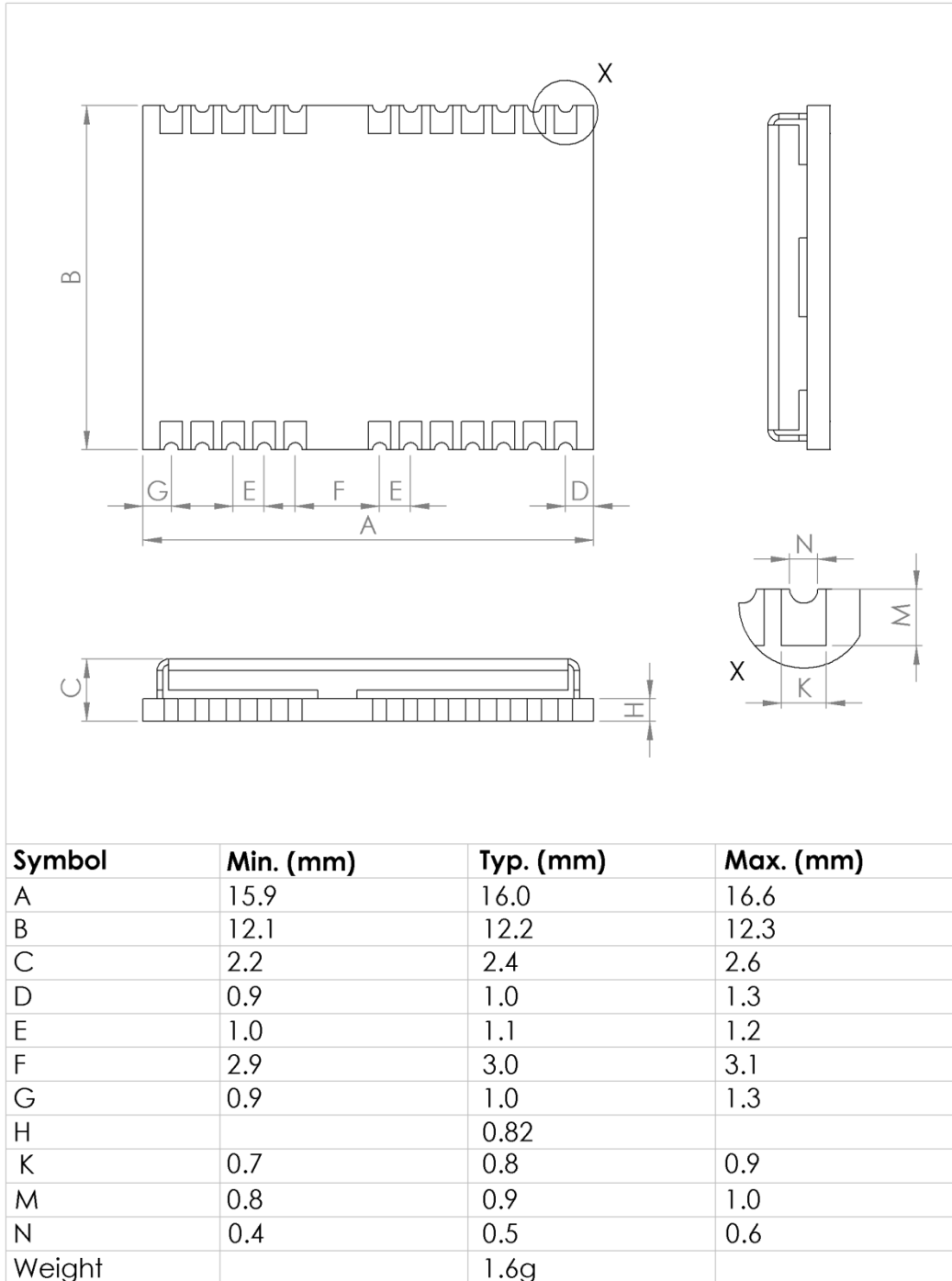

Figure 4: Dimensions



For information regarding the Paste Mask and Footprint see the LEA-6/NEO-6/MAX-6 Hardware Integration Manual [1].

5 Qualification and certification

5.1 Reliability tests



All NEO-6 modules are based on AEC-Q100 qualified GPS chips.

Tests for product family qualifications according to ISO 16750 "Road vehicles - Environmental conditions and testing for electrical and electronic equipment", and appropriate standards.

5.2 Approvals



Products marked with this lead-free symbol on the product label comply with the "Directive 2002/95/EC of the European Parliament and the Council on the Restriction of Use of certain Hazardous Substances in Electrical and Electronic Equipment" (RoHS).

All u-blox 6 GPS modules are RoHS compliant.

6 Product handling & soldering

6.1 Packaging

NEO-6 modules are delivered as hermetically sealed, reeled tapes in order to enable efficient production, production lot set-up and tear-down. For more information about packaging, see the u-blox Package Information Guide [4].



Figure 5: Reeled u-blox 6 modules

6.1.1 Reels

NEO-6 GPS modules are deliverable in quantities of 250pcs on a reel. NEO-6 modules are delivered using reel Type B as described in the u-blox Package Information Guide [4].

Parameter	Specification
Reel Type	B
Delivery Quantity	250

Table 14: Reel information for NEO-6 modules

6.1.1 Tapes

Figure 6 shows the position and orientation of NEO-6 modules as they are delivered on tape. The dimensions of the tapes are specified in Figure 7.

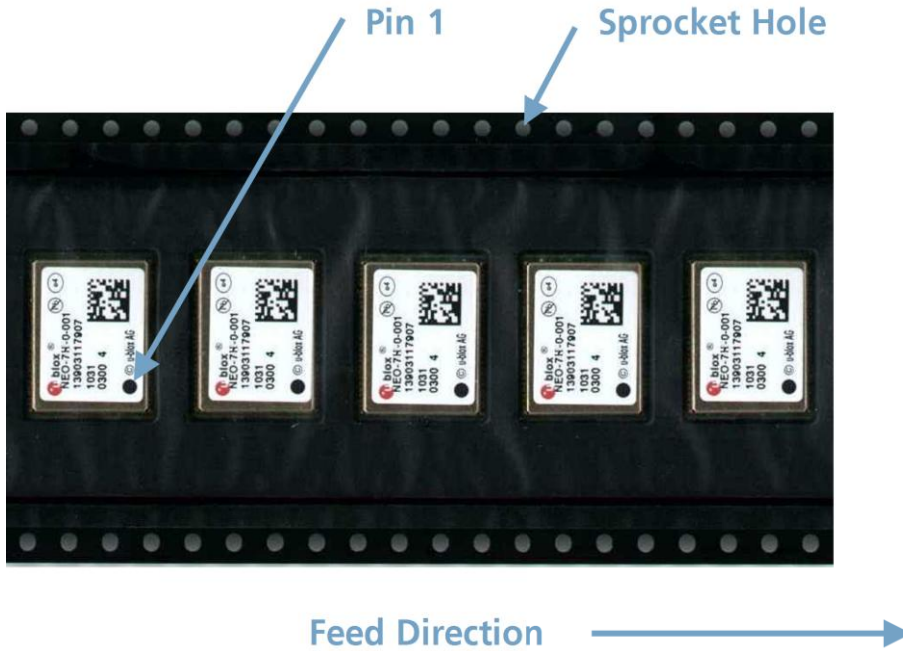
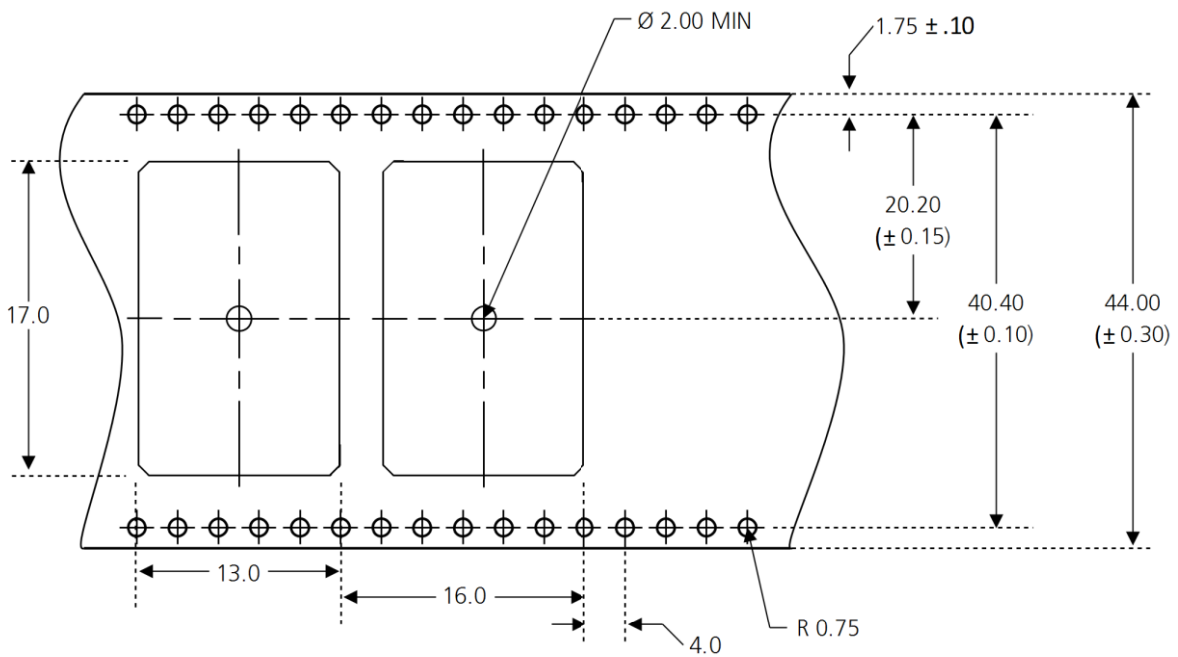

Figure 6: Orientation for NEO-6 modules on tape



Thickness of Module on Tape = 3.4(±0.1)mm

Figure 7: NEO tape dimensions (mm)

6.2 Moisture Sensitivity Levels



NEO-6 modules are Moisture Sensitive Devices (MSD) in accordance to the IPC/JEDEC specification.

NEO-6 modules are rated at MSL level 4. For more information regarding moisture sensitivity levels, labeling, storage and drying see the u-blox Package Information Guide [4].



For MSL standard see IPC/JEDEC J-STD-020, which can be downloaded from www.jedec.org.

6.3 Reflow soldering

Reflow profiles are to be selected according to u-blox recommendations (see LEA-6/NEO-6/MAX-6 Hardware Integration Manual [1]).

6.4 ESD handling precautions



NEO-6 modules contain highly sensitive electronic circuitry and are Electrostatic Sensitive Devices (ESD). Observe precautions for handling! Failure to observe these precautions can result in severe damage to the GPS receiver!



GPS receivers are Electrostatic Sensitive Devices (ESD) and require special precautions when handling. Particular care must be exercised when handling patch antennas, due to the risk of electrostatic charges. In addition to standard ESD safety practices, the following measures should be taken into account whenever handling the receiver:

- Unless there is a galvanic coupling between the local GND (i.e. the work table) and the PCB GND, then the first point of contact when handling the PCB must always be between the local GND and PCB GND.
- Before mounting an antenna patch, connect ground of the device
- When handling the RF pin, do not come into contact with any charged capacitors and be careful when contacting materials that can develop charges (e.g. patch antenna ~10pF, coax cable ~50-80pF/m, soldering iron, ...)
- To prevent electrostatic discharge through the RF input, do not touch any exposed antenna area. If there is any risk that such exposed antenna area is touched in non ESD protected work area, implement proper ESD protection measures in the design.
- When soldering RF connectors and patch antennas to the receiver's RF pin, make sure to use an ESD safe soldering iron (tip).



7 Default settings

Interface	Settings
Serial Port 1 Output	9600 Baud, 8 bits, no parity bit, 1 stop bit Configured to transmit both NMEA and UBX protocols, but only following NMEA and no UBX messages have been activated at start-up: GGA, GLL, GSA, GSV, RMC, VTG, TXT (In addition to the 6 standard NMEA messages the NEO-6T includes ZDA).
USB Output	Configured to transmit both NMEA and UBX protocols, but only following NMEA and no UBX messages have been activated at start-up: GGA, GLL, GSA, GSV, RMC, VTG, TXT (In addition to the 6 standard NMEA messages the NEO-6T includes ZDA). USB Power Mode: Bus-Powered
Serial Port 1 Input	9600 Baud, 8 bits, no parity bit, 1 stop bit Automatically accepts following protocols without need of explicit configuration: UBX, NMEA The GPS receiver supports interleaved UBX and NMEA messages.
USB Input	Automatically accepts following protocols without need of explicit configuration: UBX, NMEA The GPS receiver supports interleaved UBX and NMEA messages. USB Power Mode: Bus-Powered
TIMEPULSE (1Hz Nav)	1 pulse per second, synchronized at rising edge, pulse length 100ms
Power Mode	Maximum Performance mode
AssistNow Autonomous	Disabled.

Table 15: Default settings

Refer to the u-blox 6 Receiver Description including Protocol Specification [2] for information about further settings.

8 Labeling and ordering information

8.1 Product labeling

The labeling of u-blox 6 GPS modules includes important product information. The location of the product type number is shown in Figure 8.

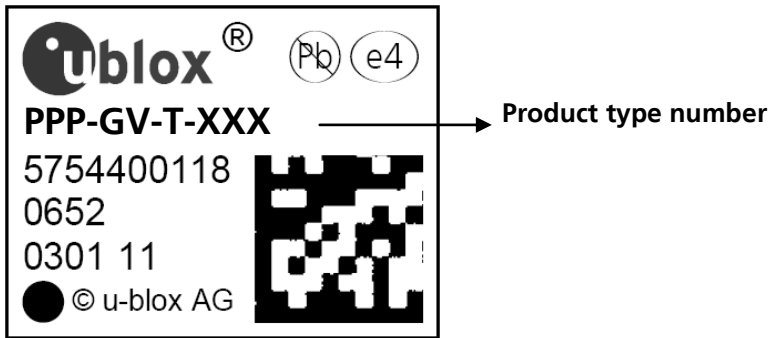

Figure 8: Location of product type number on u-blox 6 module label

8.2 Explanation of codes

3 different product code formats are used. The **Product Name** is used in documentation such as this data sheet and identifies all u-blox 6 products, independent of packaging and quality grade. The **Ordering Code** includes options and quality, while the **Type Number** includes the hardware and firmware versions. Table 16 below details these 3 different formats:

Format	Structure
Product Name	PPP-GV
Ordering Code	PPP-GV-T
Type Number	PPP-GV-T-XXX

Table 16: Product Code Formats

The parts of the product code are explained in Table 17.

Code	Meaning	Example
PPP	Product Family	NEO
G	Product Generation	6 = u-blox6
V	Variant	T = Timing, R = DR, etc.
T	Option / Quality Grade	Describes standardized functional element or quality grade such as Flash size, automotive grade etc.
XXX	Product Detail	Describes product details or options such as hard- and software revision, cable length, etc.

Table 17: part identification code

8.3 Ordering information

Ordering No.	Product
NEO-6G-0	u-blox 6 GPS Module, 1.8V, TCXO, 12x16mm, 250 pcs/reel
NEO-6M-0	u-blox 6 GPS Module, 12x16mm, 250 pcs/reel
NEO-6Q-0	u-blox 6 GPS Module, TCXO, 12x16mm, 250 pcs/reel
NEO-6P-0	u-blox 6 GPS Module, PPP, 12x16mm, 250 pcs/reel
NEO-6V-0	u-blox 6 GPS Module, Dead Reckoning SW sensor, 12x16mm, 250 pcs/reel
NEO-6T-0	u-blox 6 GPS Module, Precision Timing, TCXO, 12x16mm, 250 pcs/reel

Table 18: Product Ordering Codes



Product changes affecting form, fit or function are documented by u-blox. For a list of Product Change Notifications (PCNs) see our website at: <http://www.u-blox.com/en/notifications.html>

Related documents

- [1] LEA-6/NEO-6/MAX-6 Hardware Integration Manual, Docu. GPS.G6-HW-09007
- [2] u-blox 6 Receiver Description Including Protocol Specification (Public version), Docu. No. GPS.G6-SW-10018
- [3] u-blox 6 Receiver Description Including Protocol Specification (Confidential version), Docu. No. GPS.G6-SW-10019
- [4] u-blox Package Information Guide, Docu. No GPS-X-11004



For regular updates to u-blox documentation and to receive product change notifications please register on our homepage.

Revision history

Revision	Date	Name	Status / Comments
	31/08/2009	tgri	Initial Version
1	21/09/2009	tgri	update of section 1.3 GPS performance, section 1.4 block diagram, section 3.2 peak supply current
A	25/02/2010	tgri	Change of status to Advance Information. Addition of NEO-6G. Update of section 1.8.2, removed reference to Vddio – added USB driver certification. Update of section 3.2 table 11: average supply current, Added section 3.3-3.4: SPI & DDC timing, section 5.1: addition of table 12.
B	24/06/2010	dhur	Change of status to Preliminary. Update of section 1.2, 1.8.4, 1.10.4, 3.1, 3.2 and chapter 2 and 4. General clean-up and consistency check.
B1	11/08/2010	dhur	Replaced graphic in figure 2.
C	18/07/2011	dhur	Added chapter 1.6, update to FW7.03.
D	19/10/2011	dhur	Added NEO-6P and NEO-6V. Added chapter 1.7 and 1.8. Revised Chapter 6.
E	05/12/2011	dhur	Added NEO-6T. Added chapter 1.7 and 1.8. Added Accuracy for Timepulse signal in Table 2. Corrected Maximum Input power at RF_IN for NEO-6P in Table 9.

Contact

For complete contact information visit us at www.u-blox.com

Headquarters

u-blox AG

Zuercherstrasse 68
CH-8800 Thalwil
Switzerland

Phone: +41 44 722 74 44
Fax: +41 44 722 74 47
E-mail: info@u-blox.com

Offices

North, Central and South America

u-blox America, Inc.

Phone: +1 (703) 483 3180
E-mail: info_us@u-blox.com

Regional Office West Coast:

Phone: +1 (703) 483 3184
E-mail: info_us@u-blox.com

Technical Support:

Phone: +1 (703) 483 3185
E-mail: support_us@u-blox.com

Europe, Middle East, Africa

u-blox AG

Phone: +41 44 722 74 44
E-mail: info@u-blox.com

Technical Support:

Phone: +41 44 722 74 44
E-mail: info@u-blox.com

Asia, Australia, Pacific

u-blox Singapore Pte. Ltd.

Phone: +65 6734 3811
E-mail: info_ap@u-blox.com
Support: support_ap@u-blox.com

Regional Office China:

Phone: +86 10 68 133 545
E-mail: info_cn@u-blox.com
Support: support_cn@u-blox.com

Regional Office Japan:

Phone: +81 3 5775 3850
E-mail: info_jp@u-blox.com
Support: support_jp@u-blox.com

Regional Office Korea:



Phone: +82 2 542 0861
E-mail: info_kr@u-blox.com
Support: support_kr@u-blox.com

Regional Office Taiwan:





Phone: +886 2 2657 1090
E-mail: info_tw@u-blox.com
Support: support_tw@u-blox.com

Looking for pricing, stock, or lifecycle information?

Click below to explore more details on WIN SOURCE:

-  [View NEO-6M-0 on WIN SOURCE](#)
-  [U-blox Information](#)

Optimize Your Supply Chain with WIN SOURCE Solutions

-  Global Sourcing Solution
-  Obsolete Management
-  Cost Control Management
-  Shortage Management
-  Alternative Solution
-  Excess Inventory Management