



**THE DATASHEET OF
CS35L45-CWZR**



CS35L45

Boosted 15 Volt Mono Class D Amplifier +
Class H Boost Converter with Integrated DSP



Enables Maximum Loudness, Higher Bass and Features Next Generation
Adaptive Battery Management and Speaker Protection



CS35L45
(36-ball WLCSP package)

Maximize loudness with programmable 15 V boost voltage, 6.8 W output power and SoundClear® Playback speaker protection

Enriched sound quality with integrated DSP and SoundClear Playback enhancement

Minimize power consumption with Class H Boost, Y-bridge output driver, and low quiescent power

Intelligently regulate battery current with adaptive, predictive battery management

Save space with 6.5 mm² package footprint

Product Overview

The CS35L45 is a 55 nm smart boosted amplifier solution with an integrated DSP that drives the very loudest audio without compromising sound quality in mobile devices. The hardware platform of this flagship audio IC is designed as a mono 6.8 W boosted Class D amplifier with the lowest noise and quiescent power consumption of any amplifier in its class. Also on board is a digitally controlled Class H tracking inductive boost converter capable of boosting battery voltages up to 15 V for speaker playback. The chip includes voltage and current sensing feedback at the speaker output and the battery to improve the accuracy of integrated algorithms.

Inside the CS35L45 is a Halo Core™ DSP running robust transducer protection, advanced battery management, and audio enhancement algorithms with tuning capabilities for creating a high-performance portable audio system. Speaker protection algorithms enable maximum loudness by allowing the amplifier to safely drive high output power while ensuring that the speaker's thermal and excursion limits are not exceeded. Audio enhancement algorithms provide equalization, compression and psychoacoustic improvements to fine-tune the speaker to improve clarity, loudness and frequency response while preserving the sound quality of the audio. The CS35L45's cutting-edge battery management system adapts to speaker, audio and battery conditions to intelligently regulate average and peak battery currents without sacrificing loudness or audio quality.

The CS35L45 is housed in a 36-ball WLCSP package measuring just 6.5 mm square, which is one of the industry's smallest packages for a smart power amplifier.

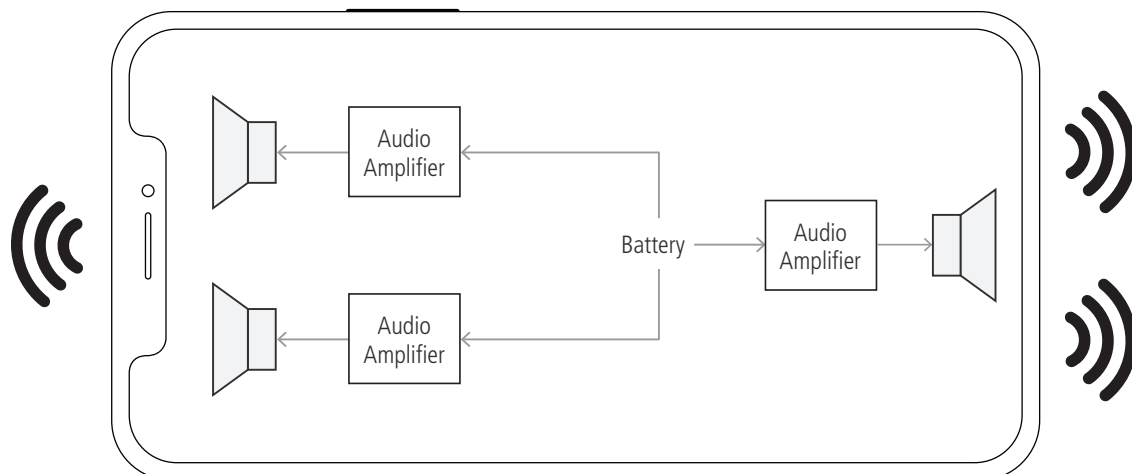

Multi-Speaker Configuration with SoundWire Control or I²C Control

Target Applications

The CS35L45 can drive mono, stereo and multiple speaker configurations for mobile and portable applications, including smartphones, tablets and mobile gaming devices.

System Features

Class D amplifier with digital input

- I²S and TDM audio interface
- SPI/I²C control data interface
- Soundwire for audio and control interface
- 15 V amplifier supply voltage
- 6.8 W @ 1% THD+N into 8 Ω
- 5 μV Idle channel noise (no noise gate)
- -79 dB THD+N @ 1 W into 8 Ω
- 43 μW hibernate mode power
- Dedicated receiver (low output power) mode for higher efficiency and talk time

Programmable DSP

- Speaker protection
- Voice coil impedance monitoring
- Over-temperature protection
- Over-excursion protection
- Adaptive battery management system using 2nd generation Predictive Input Current Limiter (PICL) algorithm with stereo audio field balance and multi-device synchronization
- Audio enhancement including equalization and compression

Class H digital boost converter

- Up to 88% overall (amplifier + boost) efficiency
- Programmable boost voltages up to 15 V
- Average and peak battery current monitoring and control
- High bandwidth digital control loop
- Pulse skipping mode for improved efficiency during low power quiescent operation

System protection

- Short circuit protection
- IC thermal self-protection against over temperature
- Battery rail reactive brownout system protection
- Speaker current sensing via integrated current monitoring sense resistor

Product Block Diagram

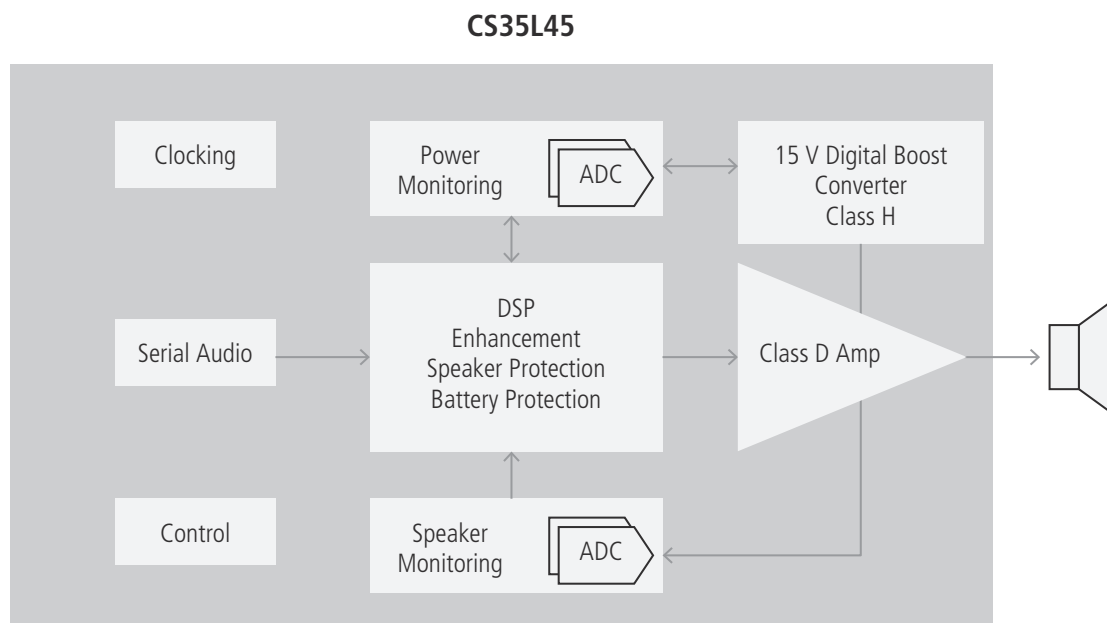

Cirrus Logic, Inc.
800 West Sixth Street
Austin, Texas 78701
United States
T+1-512-851-4000

Sales Support
North America +1-800-888-5016
Asia Pacific +852 2376-0801
Japan +81-(3)-5782-8180
Europe/UK +44-(0)-131-272-7000

cirrus.com
MARCH 2021

Looking for pricing, stock, or lifecycle information?

Click below to explore more details on WIN SOURCE:

 [View CS35L45-CWZR on WIN SOURCE](#)

 [Cirrus Logic Inc. Information](#)

Optimize Your Supply Chain with WIN SOURCE Solutions

-  Global Sourcing Solution
-  Obsolete Management
-  Cost Control Management
-  Shortage Management
-  Alternative Solution
-  Excess Inventory Management