

**Tab Size 0.64mm Automotive Compact Connector**

CONNECTOR

# MX84B Series

MB-0330-5

Jul.2020

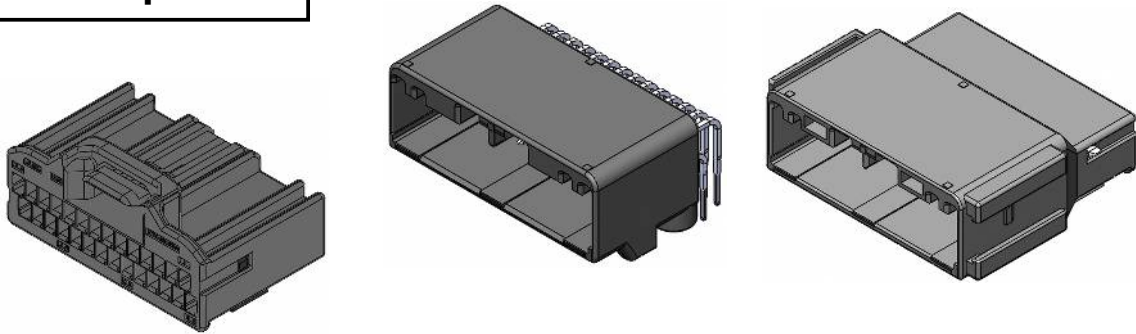
**RoHS Compliant**

To cater to the demand for insulator components with greater safety and reliability, we have added the MX84B Series using flame-retardant materials to our lineup.

With the exception of the insulator material, the MX84B Series is the same as the MX34 series, which has a proven track record in the automotive connector market.

### Applicable Market

General purpose automotive electrical control units (ECU), battery system components for electric vehicles (EV), and Battery Management System applications (BMS), flame-retardant material

- Insulator materials compliant with the flammability standard UL94 V-0
- Non-waterproof connector with 0.64mm size terminals
- Durable socket terminal that uses a 2-layer spring structure for contact area
- Retainer that detects incomplete insertion of terminals during harness work
- Bridge structure on the lock spring supports external load
- Conforming to automotive application specifications

### General Specifications

Number of Contacts	7, 12, 16, 20, 24, 28, 32, 36, 40
Rated Current	3A
Operating Temperature	-40°C ~ +85°C
Maximum Operating Temperature	130°C(Ambient temperature + temperature rise due to conduction)
Contact Resistance	Initial: 5mΩ max., posttest: 10mΩ max.

Ordering Information

**MX84B 012 N F 1**

Series

Number of Contacts: **07~40 position**

Modification Code

**1~6**: Different key mating type

Plating Specification

**F**: Sn plating

**S**: Socket Housing

**P**: Pin Housing, **N**: Angle Pin Header (DIP)

Materials and Finishes

**Socket Housing (Cable connection)**

Component	Material
Housing	PBT (UL94 V-0)
Retainer	PBT (UL94 V-0)

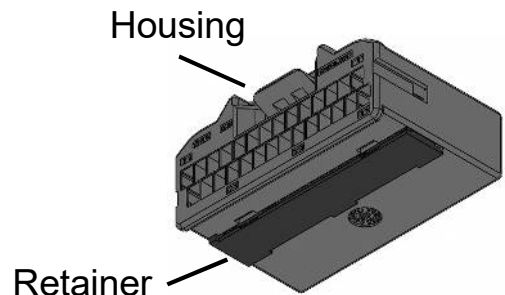

**Socket Contact (Cable connection)**

Component	Material / Finish
Contact	Highly Conductive Copper Alloy / Sn plating

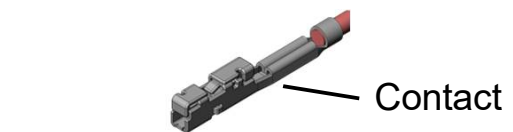

**Pin Housing (Cable connection)**

Component	Material
Housing	PBT (UL94 V-0)
Retainer	PBT (UL94 V-0)

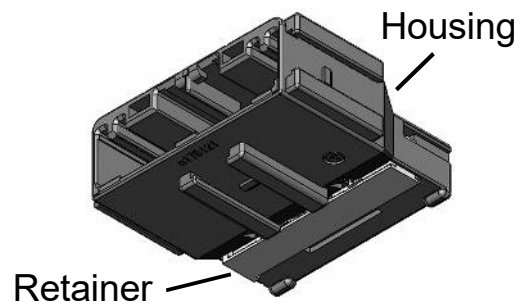

**Pin Contact (Cable connection)**

Component	Material / Finish
Contact	Highly Conductive Copper Alloy / Sn plating

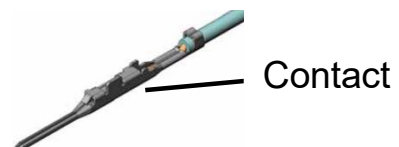

**Angle Pin Header**

Component	Material / Finish
Housing	SPS-GF30 (UL94 V-0)
Contact	Brass / Sn plating

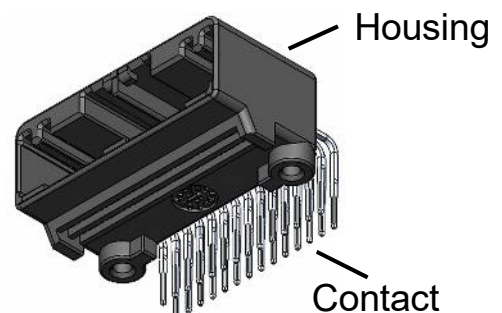

Part Number and Drawings
--------------------------

## Socket Housing / Pin Housing / Angle Pin Header

Number of Contacts	Socket Housing			Pin Housing		Angle Pin Header	
	Part Number	Drawing		Part Number	Drawing	Part Number	Drawing
7	MX84B007SF1	SJ120498	⇔	MX84B007PF1	SJ120525		
12	MX84B012SF1	SJ120500	⇔	MX84B012PF1	SJ120526	MX84B012NF1	SJ120499
16	MX84B016SF1	SJ120502	⇔	MX84B016PF1	SJ120527	MX84B016NF1	SJ120501
20	MX84B020SF1	SJ120412	⇔	MX84B020PF1	SJ120528	MX84B020NF1	SJ120411
24	MX84B024SF1	SJ120504	⇔	MX84B024PF1	SJ120529	MX84B024NF1	SJ120503
	MX84B024SF2 (Note 1)	SJ120508	⇔			MX84B024NF2 (Note 1)	SJ120507
28	MX84B028SF1	SJ120414	⇔	MX84B028PF1	SJ120530	MX84B028NF1	SJ120413
	MX84B028SF2 (Note 1)	SJ120510	⇔			MX84B028NF2 (Note 1)	SJ120509
32	MX84B032SF1	SJ120516	⇔			MX84B032NF1	SJ120515
	MX84B032SF2 (Note 1)	SJ120518	⇔			MX84B032NF2 (Note 1)	SJ120517
	MX84B032SF3 (Note 1)	SJ121895	⇔			MX84B032NF3 (Note 1, 2)	SJ121894
36	MX84B036SF1	SJ120520	⇔			MX84B036NF1	SJ120519
	MX84B036SF2 (Note 1)	SJ120522	⇔			MX84B036NF2 (Note 1)	SJ120521
40	MX84B040SF1	SJ120524	⇔			MX84B040NF1	SJ120523
	MX84B040SF2 (Note 1, 2)		⇔			MX84B040NF2 (Note 1, 2)	
	MX84B040SF3 (Note 1, 2)		⇔			MX84B040NF3 (Note 1, 2)	
	MX84B040SF4 (Note 1, 2)		⇔			MX84B040NF4 (Note 1, 2)	
	MX84B040SF5 (Note 1, 2)		⇔			MX84B040NF5 (Note 1, 2)	
	MX84B040SF6 (Note 1, 2)		⇔			MX84B040NF6 (Note 1, 2)	

Note 1) This product is different key mating type.

Note 2) This product is under development as of July, 2020. Please ask us for current status.

Part Number and Drawings
--------------------------

## Socket Contact (Cable connection type)

Part Number	Drawing	Applicable Cable
M34S75C4F1	SJ038527	AVSS 0.3mm <sup>2</sup> , CHFUS 0.22~0.35mm <sup>2</sup>
M34S75C4F2	SJ038528	AVSS 0.5mm <sup>2</sup> , CHFUS 0.5~0.75mm <sup>2</sup> CAVS 0.5mm <sup>2</sup> , CHFS 0.75mm <sup>2</sup>
M34S75C4F3 (Note 3)	SJ038747	CAN SD 0.35mm <sup>2</sup>
M34S75C4F4 (Note 3)	SJ038893	AVSS 0.85mm <sup>2</sup> , CAVS 0.85mm <sup>2</sup>
M34S75C4F5	SJ109336	CHFUS 0.13mm <sup>2</sup>

Note 4) M34S75C4F3 / 4 can only be inserted into the two housing cavity positions at the both ends of the connector.

• Handling Instruction for Crimp tool for Socket Contact is as below.

Applicable Contact	Hand Crimp Tool	Semi-automatic Applicator	Automatic Applicator
M34S75C4F1	CT150-2-MX34 (T700261)	3502-MX34D-2 (T703418)	3502-MX34D-3B (T703501)
M34S75C4F2	CT150-2B-MX34 (T700261)		
M34S75C4F5	—		
M34S75C4F3,4	CT150-2C-MX34 (T700392)	3502-MX34C-2 (Please contact us for details)	3502-MX34C-3B (Please contact us for details)

• Extraction tool for Socket Contact is "ET-MX34-1" (T711140).

## Pin Contact (Cable connection type)

Part Number	Drawing	Applicable Cable
MX84P75H4F2	SJ120531	AVSS 0.3mm <sup>2</sup> , CHFUS 0.22~0.35mm <sup>2</sup>
MX84P75H3F2	SJ120532	AVSS 0.5mm <sup>2</sup> , CHFUS 0.5~0.75mm <sup>2</sup> CAVS 0.5mm <sup>2</sup> , CHFS 0.75mm <sup>2</sup>

• Handling Instruction for Crimp tool for Pin Contact is a below.

Applicable Contact	Hand Crimp Tool	Semi-automatic Applicator	Automatic Applicator
MX84P75H4F2	CT150-2-MX34 (T700261)	3502-MX34D-2 (T703418)	3502-MX34D-3B (T703501)
MX84P75H3F2	CT150-2B-MX34 (T700261)		

• Extraction tool for Pin contact is "ET-MX34P-1" (T711154).

Technical Documents
---------------------

	Specifications	Handling Instructions
Pin Housing (Cable connection)	JACS-11205-1	JAHL-11205-3
For items other than above	JACS-11205	JAHL-11205-2

Outer Dimensions

**Socket Housing**

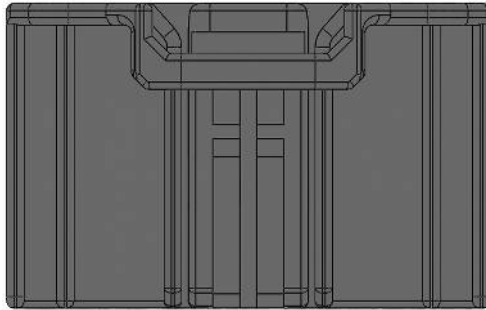

\*Drawing of 28 position type

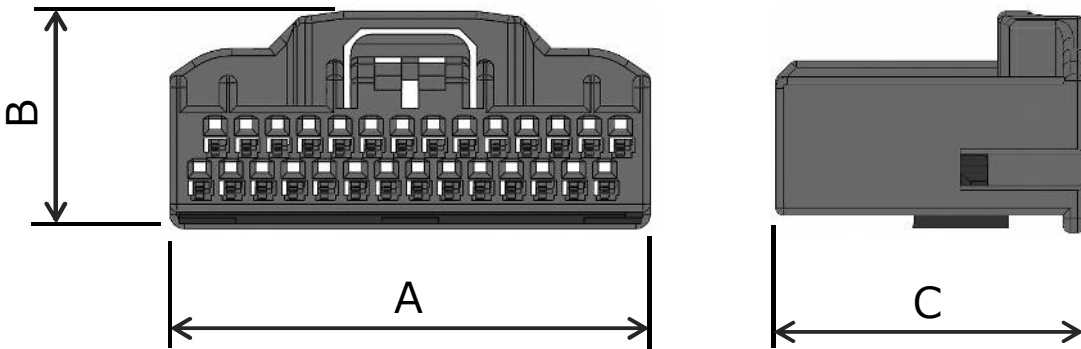

Unit: mm

Number of Contacts	Dimension A	Dimension B	Dimension C
7 position	19.6	12.2	21.3
12 position	16.3	15.2	
16 position	20.7		
20 position	25.1		
24 position	29.5		
28 position	33.9		
32 position	38.3		
36 position	42.7		
40 position	47.1		

Outer Dimensions

**Pin Housing**

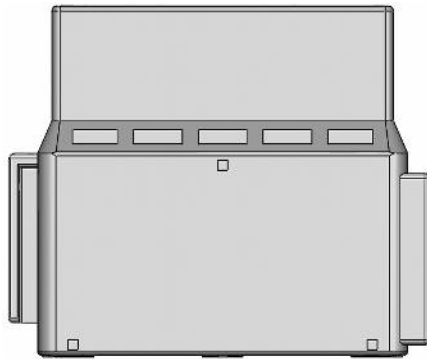

\*Drawing of 28 position type

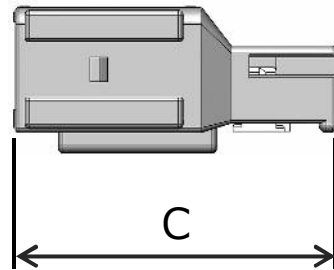
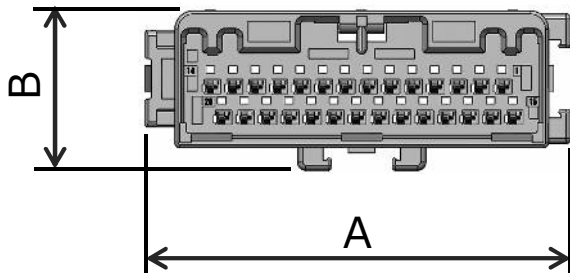

Unit: mm

Number of Contacts	Dimension A	Dimension B	Dimension C
7 position	22.2	12.6	34.8
12 position	24.2	15.6	
16 position	28.6		
20 position	33		
24 position	37.4		
28 position	41.8		

Outer Dimensions

Angle Pin Header

\*Drawing of 28 position type

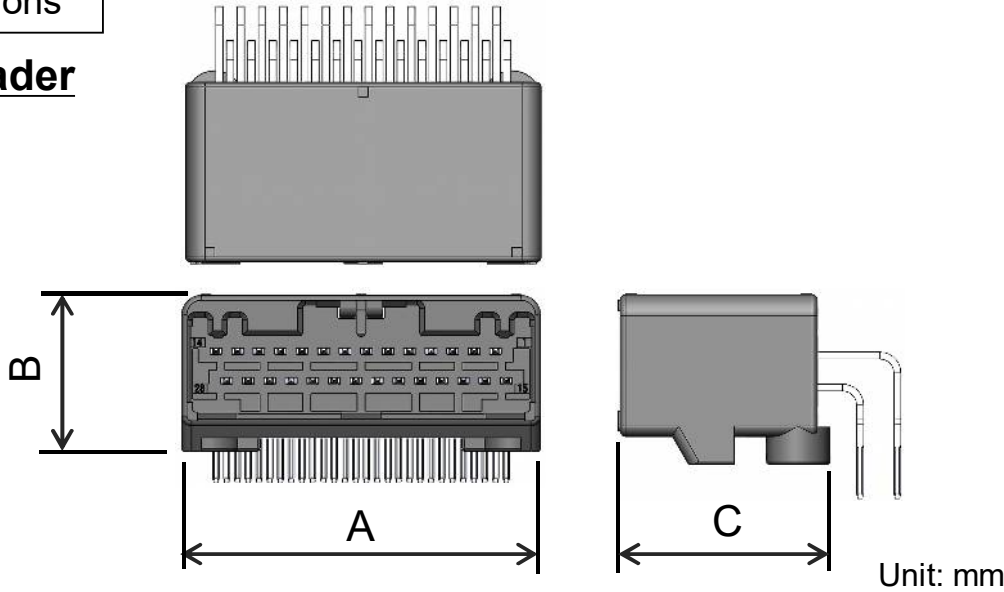

Number of Contacts	Dimension A	Dimension B	Dimension C
12 position	19.1	16.0	19.9
16 position	23.5		
20 position	27.9		
24 position	32.3		
28 position	36.7		
32 position	41.1		
36 position	45.5		
40 position	49.9		

**Notice:**

1. The values specified in this brochure are only for reference. The products and their specifications are subject to change without notice. Contact our sales staff for further information before considering or ordering any of our products. For purchase, a product specification must be agreed upon.
2. Users are requested to provide protection circuits and redundancy circuits to ensure safety of the equipment, and sufficiently review the suitability of JAE's products to the equipment.
3. The products presented in this brochure are designed for the uses recommended below. We strongly suggest you contact our sales staff when considering use of any of the products in any other way than the recommended applications or for a specific use that requires an extremely high reliability.
  - (1) Applications that require consultation:
    - (i) Please contact us if you are considering use involving a quality assurance program that you specify or that is peculiar to the industry, such as:  
Automotive electrical components, train control, telecommunications devices (mainline), traffic light control, electric power, combustion control, fire prevention or security systems, disaster prevention equipment, etc.
    - (ii) We may separately give you our support with a quality assurance program that you specify, when you think of a use such as :  
Aviation or space equipment, submarine repeaters, nuclear power control systems, medical equipment for life support, etc.
  - (2) Recommended applications include:  
Computers, office appliances, telecommunications devices (terminals, mobile units), measuring equipment, audiovisual equipment, home electric appliances, factory automation equipment, etc.



**Japan Aviation Electronics Industry, Limited**

Advanced-Product Development Planning Dept. Connector Division  
 Aobadai Building, 3-1-19, Aobadai, Meguro-ku, Tokyo 153-8539  
 Phone: +81-3-3780-2882 FAX: +81-3-3780-2946





\* The specifications in this brochure are subject to change without notice. Please contact JAE for information.

## Looking for pricing, stock, or lifecycle information?

Click below to explore more details on WIN SOURCE:

-  [View MX84B040SF1 on WIN SOURCE](#)
-  [JAE Electronics Information](#)

## Optimize Your Supply Chain with WIN SOURCE Solutions

-  Global Sourcing Solution
-  Obsolete Management
-  Cost Control Management
-  Shortage Management
-  Alternative Solution
-  Excess Inventory Management