



**THE DATASHEET OF  
ICS9248BF-138LF**





# Frequency Generator & Integrated Buffers for Celeron & PIII/III<sup>TM</sup>

**Recommended Application:**  
810/810E and Solano type chipset.

**Output Features:**

- 2- CPUs @ 2.5V
- 9 - SDRAM @ 3.3V, including 1 free running
- 7 - PCICLK @ 3.3V
- 1 - IOAPIC @ 2.5V,
- 3 - 3V66MHz @ 3.3V
- 2 - 48MHz, @ 3.3V fixed.
- 1 - 24/48MHz, @3.3V selectable by I<sup>2</sup>C
- 1 - REF @v3.3V, 14.318MHz.

**Features:**

- Up to 200MHz frequency support
- Support FS0-FS4 strapping status bit for I<sup>2</sup>C read back.
- Support power management: Through Power down Mode from I<sup>2</sup>C programming.
- Spread spectrum for EMI control ( ± 0.25% center).
- Uses external 14.318MHz crystal

**Skew Specifications:**

- CPU – CPU: <175ps
- SDRAM - SDRAM: < 250ps
- 3V66 – 3V66: <175ps
- PCI – PCI: <500ps
- For group skew specifications, please refer to group timing relationship.

**Pin Configuration**

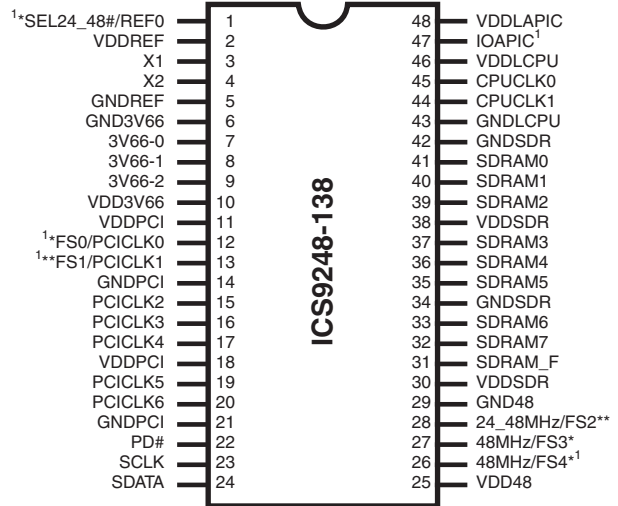

**48-Pin 300mil SSOP**

- \* These inputs have a 120K pull up to VDD.
- \*\* These inputs have a 120K pull down to GND.
- 1 These are double strength.

**Block Diagram**

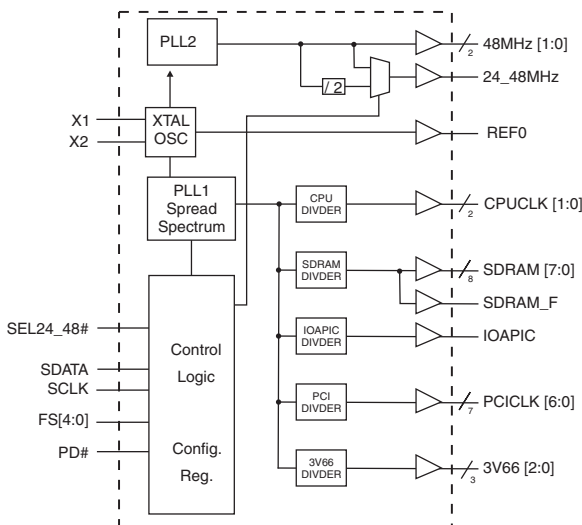

**Functionality**

FS4	FS3	FS2	FS1	FS0	CPU (MHz)	SDRAM (MHz)	3V66 (MHz)	PCICLK (MHz)	IOAPIC (MHz)
0	0	0	0	0	66.67	100.00	66.67	33.33	16.67
0	0	0	0	1	66.87	100.30	66.87	33.43	16.72
0	0	0	1	0	68.67	103.00	68.67	34.33	17.16
0	0	0	1	1	71.34	107.00	71.34	35.66	17.83
0	0	1	0	0	100.00	100.00	66.67	33.33	16.67
0	0	1	0	1	100.30	100.30	66.87	33.43	16.72
0	0	1	1	0	103.00	103.00	68.67	34.33	17.17
0	0	1	1	1	107.00	107.00	71.34	35.66	17.84
0	1	0	0	0	133.33	133.33	66.67	33.33	16.67
0	1	0	0	1	133.73	133.73	66.87	33.43	16.72
0	1	0	1	0	137.33	137.33	68.67	34.33	17.17
0	1	0	1	1	120.00	120.00	60.00	30.00	15.00
0	1	1	0	0	133.33	100.00	66.67	33.33	16.67
0	1	1	0	1	133.73	100.30	66.87	33.43	16.72
0	1	1	1	0	137.33	103.00	68.67	34.33	17.17
0	1	1	1	1	120.00	90.00	60.00	30.00	15.00
⋮									
1	1	0	1	0	160.00	160.00	80.00	40.00	20.00
1	1	1	0	1	160.00	120.00	80.00	40.00	20.00
1	1	0	1	1	166.67	166.67	83.34	41.67	20.84
1	1	1	1	0	166.67	125.00	83.34	41.67	20.84

Additional frequencies selectable through I<sup>2</sup>C programming.



## General Description

The **ICS9248-138** is the single chip clock solution for designs using the 810/810E and Solano style chipset. It provides all necessary clock signals for such a system.

Spread spectrum may be enabled through I<sup>2</sup>C programming. Spread spectrum typically reduces system EMI by 8dB to 10dB. This simplifies EMI qualification without resorting to board design iterations or costly shielding. The ICS9248-138 employs a proprietary closed loop design, which tightly controls the percentage of spreading over process and temperature variations.

Serial programming I<sup>2</sup>C interface allows changing functions, stop clock programming and frequency selection.

## Pin Configuration

PIN NUMBER	PIN NAME	TYPE	DESCRIPTION
1	SEL24_48MHz#	IN	Logic inputs frequency select I/O/USB output, When a "0" is latched, output frequency = 48MHz When a "1" is latched, output frequency = 24MHz
	REF0	OUT	14.318 MHz reference clock.
2, 10, 11, 18, 25, 30, 38	VDD	PWR	3.3V Power supply for SDRAM output buffers, PCI output buffers, reference output buffers and 48MHz output
3	X1	IN	Crystal input, nominally 14.318MHz.
4	X2	OUT	Crystal output, nominally 14.318MHz.
5, 6, 14, 21, 29, 34, 42	GND	PWR	Ground pin for 3V outputs.
9, 8, 7	3V66 [2:0]	OUT	3.3V Clocks
12	FS0	IN	Frequency select pin.
	PCICLK0	OUT	PCI clock output
13	FS1	IN	Frequency select pin.
	PCICLK1	OUT	PCI clock output
20, 19, 17, 16, 15	PCICLK [6:2]	OUT	PCI clock outputs.
22	PD#	IN	Asynchronous active low input pin used to power down the device into a low power state. The internal clocks are disabled and the VCO and the crystal are stopped. The latency of the power down will not be greater than 3ms.
23	SCLK	IN	Clock input of I2C input, 5V tolerant input
24	SDATA	IN	Data input for I2C serial input, 5V tolerant input
26	FS4	IN	Frequency select pin.
	48MHz	OUT	48MHz output clocks
27	FS3	IN	Frequency select pin.
	48MHz	OUT	48MHz output clocks
28	FS2	IN	Frequency select pin.
	24_48MHz	OUT	24 or 48MHz output
31	SDRAM_F	OUT	Free running SDRAM - used for feed back to chipset, should remain on always.
32, 33, 35, 36, 37, 39, 40, 41,	SDRAM [7:0]	OUT	SDRAM clock outputs
43	GNDLCPU	PWR	Ground pin for the CPU clocks.
44, 45	CPUCLK [1:0]	OUT	CPU clock outputs.
46	VDDLCPUCPU	PWR	Power pin for the CPUCLKs. 2.5V
47	IOAPIC	OUT	2.5V clock output
48	VDDLAPIC	PWR	Power pin for the IOAPIC. 2.5V



## Serial Configuration Command Bitmap

Byte0: Functionality and Frequency Select Register (default = 0)

Bit	Description											PWD
Bit 2, 7:4	bit2	bit7	bit6	bit5	bit4	CPUCLK (MHz)	SDRAM (MHz)	3V66 (MHz)	PCICLK (MHz)	IOAPIC (MH)	Spread Percentage	(0,0001)
	FS4	FS3	FS2	FS1	FS0							
	0	0	0	0	0	66.67	100.00	66.67	33.33	16.67	0 to -0.5% Down Spread	
	0	0	0	0	1	66.87	100.30	66.87	33.43	16.72	± 0.25% Center Spread	
	0	0	0	1	0	68.67	103.00	68.67	34.33	17.16	± 0.25% Center Spread	
	0	0	0	1	1	71.34	107.00	71.34	35.67	17.83	± 0.25% Center Spread	
	0	0	1	0	0	100.00	100.00	66.67	33.33	16.67	0 to -0.5% Down Spread	
	0	0	1	0	1	100.30	100.30	66.87	33.43	16.72	± 0.25% Center Spread	
	0	0	1	1	0	103.00	103.00	68.67	34.33	17.17	± 0.25% Center Spread	
	0	0	1	1	1	107.00	107.00	71.34	35.67	17.84	± 0.25% Center Spread	
	0	1	0	0	0	133.33	133.33	66.67	33.33	16.67	0 to -0.5% Down Spread	
	0	1	0	0	1	133.73	133.73	66.87	33.43	16.72	± 0.25% Center Spread	
	0	1	0	1	0	137.33	137.33	68.67	34.33	17.17	± 0.25% Center Spread	
	0	1	0	1	1	120.00	120.00	60.00	30.00	15.00	± 0.25% Center Spread	
	0	1	1	0	0	133.33	100.00	66.67	33.33	16.67	0 to -0.5% Down Spread	
	0	1	1	0	1	133.73	100.30	66.87	33.43	16.72	± 0.25% Center Spread	
	0	1	1	1	0	137.33	103.00	68.67	34.33	17.17	± 0.25% Center Spread	
	0	1	1	1	1	120.00	90.00	60.00	30.00	15.00	± 0.25% Center Spread	
	1	0	0	0	0	136.00	136.00	68.00	34.00	17.00	± 0.25% Center Spread	
	1	0	0	0	1	140.00	140.00	70.00	35.00	17.50	± 0.25% Center Spread	
	1	0	0	1	0	142.67	142.67	71.34	35.67	17.84	± 0.25% Center Spread	
	1	0	0	1	1	145.33	145.33	72.67	36.33	18.17	± 0.25% Center Spread	
	1	0	1	0	0	136.00	102.00	68.00	34.00	17.00	± 0.25% Center Spread	
	1	0	1	0	1	140.00	105.00	70.00	35.00	17.50	± 0.25% Center Spread	
	1	0	1	1	0	142.67	107.00	71.34	35.67	17.84	± 0.25% Center Spread	
	1	0	1	1	1	145.33	109.00	72.67	36.33	18.17	± 0.25% Center Spread	
	1	1	0	0	0	146.67	146.67	73.34	36.67	18.34	± 0.25% Center Spread	
	1	1	0	0	1	153.33	153.33	76.67	38.33	19.17	± 0.25% Center Spread	
1	1	0	1	0	160.00	160.00	80.00	40.00	20.00	± 0.25% Center Spread		
1	1	0	1	1	166.67	166.67	83.34	41.67	20.84	± 0.25% Center Spread		
1	1	1	0	0	146.67	110.00	73.34	36.67	18.34	± 0.25% Center Spread		
1	1	1	0	1	160.00	120.00	80.00	40.00	20.00	± 0.25% Center Spread		
1	1	1	1	0	166.67	125.00	83.34	41.67	20.84	± 0.25% Center Spread		
1	1	1	1	1	200.00	200.00	66.67	33.33	16.67	± 0.25% Center Spread		
Bit 3	0 - Frequency is selected by hardware select, Latched Inputs 1 - Frequency is selected by Bit 2, 6:4											0
Bit 1	0 - Normal 1 - Spread Spectrum Enabled ± 0.25% Center Spread											0
Bit 0	0 - Running 1- Tristate all outputs											0

**Note 1:** Default at power-up will be for latched logic inputs to define frequency, as displayed by Bit 3.

i<sup>2</sup>C is a trademark of Philips Corporation



**Byte 1: SDRAM Control Register**  
(1= enable, 0 = disable)

BIT	PIN#	PWD	DESCRIPTION
Bit 7	-	X	FS2#
Bit 6	-	X	FS1#
Bit 5	31	1	SDRAM_F
Bit 4	32	1	SDRAM7
Bit 3	33	1	SDRAM6
Bit 2	35	1	SDRAM5
Bit 1	36	1	SDRAM4
Bit 0	37	1	SDRAM3

**Byte 2: PCI, Control Register**  
(1= enable, 0 = disable)

BIT	PIN#	PWD	DESCRIPTION
Bit 7	-	X	FS0#
Bit 6	20	1	PCICLK6
Bit 5	19	1	PCICLK5
Bit 4	17	1	PCICLK4
Bit 3	16	1	PCICLK3
Bit 2	15	1	PCICLK2
Bit 1	13	1	PCICLK1
Bit 0	12	1	PCICLK0

**Byte 3: 3V66, Control Register**  
(1= enable, 0 = disable)

BIT	PIN#	PWD	DESCRIPTION
Bit 7	-	X	FS4#
Bit 6	-	1	Reserved
Bit 5	-	1	Reserved
Bit 4	-	1	Reserved
Bit 3	-	1	Reserved
Bit 2	7	1	3V66-0
Bit 1	8	1	3V66-1
Bit 0	9	1	3V66-2

**Byte 4: Control Register**  
(1= enable, 0 = disable)

BIT	PIN#	PWD	DESCRIPTION
Bit 7	-	1	Reserved
Bit 6	-	1	Reserved
Bit 5	-	1	Reserved
Bit 4	-	1	Reserved
Bit 3	-	1	Reserved
Bit 2	27	1	48MHz-0
Bit 1	26	1	48MHz-1
Bit 0	28	1	24_48MHz

**Byte 5: Control Register**  
(1= enable, 0 = disable)

BIT	PIN#	PWD	DESCRIPTION
Bit7	-	X	(SEL24_48#)#
Bit6	1	1	REF0
Bit5	47	1	IOAPIC
Bit4	44	1	CPUCLK1
Bit3	45	1	CPUCLK0
Bit2	39	1	SDRAM2
Bit1	40	1	SDRAM1
Bit0	41	1	SDRAM0

**Byte 6: Control Register**  
(1= enable, 0 = disable)

BIT	PIN#	PWD	DESCRIPTION
Bit7	-	0	Reserved (Note)
Bit6	-	0	Reserved (Note)
Bit5	-	0	Reserved (Note)
Bit4	-	0	Reserved (Note)
Bit3	-	0	Reserved (Note)
Bit2	-	1	Reserved (Note)
Bit1	-	1	Reserved (Note)
Bit0	-	0	Reserved (Note)

**Notes:**

1. Inactive means outputs are held LOW and are disabled from switching.
2. Latched Frequency Selects (FS#) will be inverted logic load of the input frequency select pin conditions.

**Note: Don't write into this register, writing into this register can cause malfunction. This Byte becomes the Byte Count for Readback, so it cannot be seen as data.**



### Absolute Maximum Ratings

Core Supply Voltage ..... 5.5 V  
 I/O Supply Voltage ..... 3.6V  
 Logic Inputs ..... GND –0.5 V to V<sub>DD</sub> +0.5 V  
 Ambient Operating Temperature ..... 0°C to +70°C  
 Storage Temperature ..... –65°C to +150°C

Stresses above those listed under *Absolute Maximum Ratings* may cause permanent damage to the device. These ratings are stress specifications only and functional operation of the device at these or any other conditions above those listed in the operational sections of the specifications is not implied. Exposure to absolute maximum rating conditions for extended periods may affect product reliability.

### Group Timing Relationship Table

Group	CPU 66MHz SDRAM 100MHz		CPU 100MHz SDRAM 100MHz		CPU 133MHz SDRAM 100MHz		CPU 133MHz SDRAM 133MHz	
	Offset	Tolerance	Offset	Tolerance	Offset	Tolerance	Offset	Tolerance
CPU to SDRAM	2.5ns	500ps	5.0ns	500ps	0.0ns	500ps	3.75ns	500ps
CPU to 3V66	7.5ns	500ps	5.0ns	500ps	0.0ns	500ps	0.0ns	500ps
SDRAM to 3V66	0.0ns	500ps	0.0ns	500ps	0.0ns	500ps	3.75ns	500ps
3V66 to PCI	1.5-3.5ns	500ps	1.5-3.5ns	500ps	1.5-3.5ns	500ps	1.5 -3.5ns	500ps
PCI to PCI	0.0ns	1.0ns	0.0ns	1.0ns	0.0ns	1.0ns	0.0ns	1.0ns
USB & DOT	Asynch	N/A	Asynch	N/A	Asynch	N/A	Asynch	N/A

### Electrical Characteristics - Input/Supply/Common Output Parameters

T<sub>A</sub> = 0 - 70°C; Supply Voltage V<sub>DD</sub> = 3.3 V ±5%, VDDL=2.5 V± 5%(unless otherwise stated)

PARAMETER	SYMBOL	CONDITIONS	MIN	TYP	MAX	UNITS
Input High Voltage	V <sub>IH</sub>		2		V <sub>DD</sub> + 0.3	V
Input Low Voltage	V <sub>IL</sub>		V <sub>SS</sub> - 0.3		0.8	V
Input High Current	I <sub>IH</sub>	V <sub>IN</sub> = V <sub>DD</sub>	-5		5	mA
Input Low Current	I <sub>IL1</sub>	V <sub>IN</sub> = 0 V; Inputs with no pull-up resistors	-5			mA
Input Low Current	I <sub>IL2</sub>	V <sub>IN</sub> = 0 V; Inputs with pull-up resistors	-200			mA
Operating Supply Current	I <sub>DD3.3OP</sub>	C <sub>L</sub> = 0 pF; Select @ 66M			100	mA
Power Down Supply Current	I <sub>DD3.3PD</sub>	C <sub>L</sub> = 0 pF; With input address to V <sub>DD</sub> or GND			600	mA
Input frequency	F <sub>i</sub>	V <sub>DD</sub> = 3.3 V;		14.318		MHz
Pin Inductance	L <sub>pin</sub>				7	nH
Input Capacitance <sup>1</sup>	C <sub>IN</sub>	Logic Inputs			5	pF
	C <sub>out</sub>	Out put pin capacitance			6	pF
	C <sub>INX</sub>	X1 & X2 pins	27		45	pF
Transition Time <sup>1</sup>	T <sub>trans</sub>	To 1st crossing of target Freq.			3	mS
Settling Time <sup>1</sup>	T <sub>s</sub>	From 1st crossing to 1% target Freq.			3	mS
Clk Stabilization <sup>1</sup>	T <sub>STAB</sub>	From V <sub>DD</sub> = 3.3 V to 1% target Freq.			3	mS
Delay	t <sub>PZH</sub> , t <sub>PZH</sub>	output enable delay (all outputs)	1		10	nS
	t <sub>PLZ</sub> , t <sub>PZH</sub>	output disable delay (all outputs)	1		10	nS

<sup>1</sup>Guaranteed by design, not 100% tested in production.



### Electrical Characteristics - CPU

$T_A = 0 - 70^\circ\text{C}$ ,  $V_{DDL} = 2.5 \text{ V} \pm 5\%$ ;  $C_L = 10 - 20 \text{ pF}$  (unless otherwise stated)

PARAMETER	SYMBOL	CONDITIONS	MIN	TYP	MAX	UNITS
Output Impedance	$R_{DSP2B}^1$	$V_O = V_{DD}^*(0.5)$	13.5		45	$\Omega$
Output Impedance	$R_{DSN2B}^1$	$V_O = V_{DD}^*(0.5)$	13.5		45	$\Omega$
Output High Voltage	$V_{OH2B}$	$I_{OH} = -1 \text{ mA}$	2			V
Output Low Voltage	$V_{OL2B}$	$I_{OL} = 1 \text{ mA}$			0.4	V
Output High Current	$I_{OH2B}$	$V_{OH@MIN} = 1.0 \text{ V}$ , $V_{OH@MAX} = 2.375 \text{ V}$	-27		-27	mA
Output Low Current	$I_{OL2B}$	$V_{OL@MIN} = 1.2 \text{ V}$ , $V_{OL@MAX} = 0.3 \text{ V}$	27		30	mA
Rise Time	$t_{r2B}^1$	$V_{OL} = 0.4 \text{ V}$ , $V_{OH} = 2.0 \text{ V}$	0.4		1.6	ns
Fall Time	$t_{f2B}^1$	$V_{OH} = 0.4 \text{ V}$ , $V_{OL} = 2.0 \text{ V}$	0.4		1.6	ns
Duty Cycle	$d_{t2B}^1$	$V_T = 1.25 \text{ V}$	45		55	%
Skew	$t_{sk2B}^1$	$V_T = 1.25 \text{ V}$			250	ps
Jitter	$t_{jycyc-cyc}^1$	$V_T = 1.25 \text{ V}$			250	ps

<sup>1</sup>Guaranteed by design, not 100% tested in production.

### Electrical Characteristics - 3V66

$T_A = 0 - 70^\circ\text{C}$ ;  $V_{DD} = 3.3 \text{ V} \pm 5\%$ ;  $C_L = 10-30 \text{ pF}$  (unless otherwise stated)

PARAMETER	SYMBOL	CONDITIONS	MIN	TYP	MAX	UNITS
Output Impedance	$R_{DSP1}^1$	$V_O = V_{DD}^*(0.5)$	12		55	$\Omega$
Output Impedance	$R_{DSN1}^1$	$V_O = V_{DD}^*(0.5)$	12		55	$\Omega$
Output High Voltage	$V_{OH1}$	$I_{OH} = -1 \text{ mA}$	2.4			V
Output Low Voltage	$V_{OL1}$	$I_{OL} = 1 \text{ mA}$			0.55	V
Output High Current	$I_{OH1}$	$V_{OH@MIN} = 1.0 \text{ V}$ , $V_{OH@MAX} = 3.135 \text{ V}$	-33		-33	mA
Output Low Current	$I_{OL1}$	$V_{OL@MIN} = 1.95 \text{ V}$ , $V_{OL@MAX} = 0.4$	30		38	mA
Rise Time	$t_{r1}^1$	$V_{OL} = 0.4 \text{ V}$ , $V_{OH} = 2.4 \text{ V}$	0.5		2	ns
Fall Time	$t_{f1}^1$	$V_{OH} = 2.4 \text{ V}$ , $V_{OL} = 0.4 \text{ V}$	0.5		2	ns
Duty Cycle	$d_{t1}^1$	$V_T = 1.5 \text{ V}$	45		55	%
Skew	$t_{sk1}^1$	$V_T = 1.5 \text{ V}$			175	ps
Jitter	$t_{jycyc-cyc}^1$	$V_T = 1.5 \text{ V}$			500	ps

<sup>1</sup>Guaranteed by design, not 100% tested in production.



### Electrical Characteristics - IOAPIC

T<sub>A</sub> = 0 - 70°C; V<sub>DDL</sub> = 2.5 V +/-5%; C<sub>L</sub> = 10 - 20 pF (unless otherwise stated)

PARAMETER	SYMBOL	CONDITIONS	MIN	TYP	MAX	UNITS
Output Impedance	R <sub>DSP4B</sub> <sup>1</sup>	V <sub>O</sub> = V <sub>DD</sub> * (0.5)	9		30	Ω
Output Impedance	R <sub>DSN4B</sub> <sup>1</sup>	V <sub>O</sub> = V <sub>DD</sub> * (0.5)	9		30	Ω
Output High Voltage	V <sub>OH4B</sub>	I <sub>OH</sub> = -5.5 mA	2			V
Output Low Voltage	V <sub>OL4B</sub>	I <sub>OL</sub> = 9.0 mA			0.4	V
Output High Current	I <sub>OH4B</sub>	V <sub>OH@ min</sub> = 1.0 V, V <sub>OH@ MAX</sub> = 2.375 V	-27		-27	mA
Output Low Current	I <sub>OL4B</sub>	V <sub>OL@ MIN</sub> = 1.2 V, V <sub>OL@ MAX</sub> = 0.3 V	27		30	mA
Rise Time	t <sub>r4B</sub> <sup>1</sup>	V <sub>OL</sub> = 0.4 V, V <sub>OH</sub> = 2.0 V	0.4		1.6	ns
Fall Time	t <sub>f4B</sub> <sup>1</sup>	V <sub>OH</sub> = 2.0 V, V <sub>OL</sub> = 0.4 V	0.4		1.6	ns
Duty Cycle	d <sub>t4B</sub> <sup>1</sup>	V <sub>T</sub> = 1.25 V	45		55	%
Skew	t <sub>sk4</sub> <sup>1</sup>				250	ps
Jitter	t <sub>j cyc-cyc</sub>	V <sub>T</sub> = 1.25 V			500	ps

<sup>1</sup>Guaranteed by design, not 100% tested in production.

### Electrical Characteristics - SDRAM

T<sub>A</sub> = 0 - 70°C; V<sub>DD</sub> = V<sub>DDL</sub> = 3.3 V +/-5%; C<sub>L</sub> = 20 - 30 pF (unless otherwise stated)

PARAMETER	SYMBOL	CONDITIONS	MIN	TYP	MAX	UNITS
Output Impedance	R <sub>DSP3</sub> <sup>1</sup>	V <sub>O</sub> = V <sub>DD</sub> * (0.5)	10		24	Ω
Output Impedance	R <sub>DSN3</sub> <sup>1</sup>	V <sub>O</sub> = V <sub>DD</sub> * (0.5)	10		24	Ω
Output High Voltage	V <sub>OH3</sub>	I <sub>OH</sub> = -1 mA	2.4			V
Output Low Voltage	V <sub>OL3</sub>	I <sub>OL</sub> = 1 mA			0.4	V
Output High Current	I <sub>OH3</sub>	V <sub>OH@ MIN</sub> = 2.0 V, V <sub>OH@ MAX</sub> = 3.135 V	-54		-46	mA
Output Low Current	I <sub>OL3</sub>	V <sub>OL@ MIN</sub> = 1.0 V, V <sub>OL@ MAX</sub> = 0.4 V	54		53	mA
Rise Time	T <sub>r3</sub> <sup>1</sup>	V <sub>OL</sub> = 0.4 V, V <sub>OH</sub> = 2.4 V	0.4		1.6	ns
Fall Time	T <sub>f3</sub> <sup>1</sup>	V <sub>OH</sub> = 2.4 V, V <sub>OL</sub> = 0.4 V	0.4		1.6	ns
Duty Cycle	D <sub>t3</sub> <sup>1</sup>	V <sub>T</sub> = 1.5 V	45		55	%
Skew	T <sub>sk3</sub> <sup>1</sup>	V <sub>T</sub> = 1.5 V			250	ps
Jitter	t <sub>j cyc-cyc</sub>	V <sub>T</sub> = 1.5 V			250	ps

<sup>1</sup>Guaranteed by design, not 100% tested in production.



### Electrical Characteristics - PCI

$T_A = 0 - 70^\circ\text{C}$ ;  $V_{DD} = 3.3\text{ V} \pm 5\%$ ;  $C_L = 10\text{-}30\text{ pF}$  (unless otherwise stated)

PARAMETER	SYMBOL	CONDITIONS	MIN	TYP	MAX	UNITS
Output Impedance	$R_{DSP1}^1$	$V_O = V_{DD}^*(0.5)$	12		55	$\Omega$
Output Impedance	$R_{DSN1}^1$	$V_O = V_{DD}^*(0.5)$	12		55	$\Omega$
Output High Voltage	$V_{OH1}$	$I_{OH} = -1\text{ mA}$	2.4			V
Output Low Voltage	$V_{OL1}$	$I_{OL} = 1\text{ mA}$			0.55	V
Output High Current	$I_{OH1}$	$V_{OH@MIN} = 1.0\text{ V}$ , $V_{OH@MAX} = 3.135\text{ V}$	-33		-33	mA
Output Low Current	$I_{OL1}$	$V_{OL@MIN} = 1.95\text{ V}$ , $V_{OL@MAX} = 0.4\text{ V}$	30		38	mA
Rise Time	$t_{r1}^1$	$V_{OL} = 0.4\text{ V}$ , $V_{OH} = 2.4\text{ V}$	0.5		2	ns
Fall Time	$t_{f1}^1$	$V_{OH} = 2.4\text{ V}$ , $V_{OL} = 0.4\text{ V}$	0.5		2	ns
Duty Cycle	$d_{t1}^1$	$V_T = 1.5\text{ V}$	45		55	%
Skew	$t_{sk1}^1$	$V_T = 1.5\text{ V}$			500	ps
Jitter	$t_{jyc-cyc}^1$	$V_T = 1.5\text{ V}$			500	ps

<sup>1</sup>Guaranteed by design, not 100% tested in production.

### Electrical Characteristics - REF, 48MHz\_0

$T_A = 0 - 70^\circ\text{C}$ ;  $V_{DD} = V_{DDL} = 3.3\text{ V} \pm 5\%$ ;  $C_L = 10 - 20\text{ pF}$  (unless otherwise stated)

PARAMETER	SYMBOL	CONDITIONS	MIN	TYP	MAX	UNITS
Output Impedance	$R_{DSP5}^1$	$V_O = V_{DD}^*(0.5)$	20		60	$\Omega$
Output Impedance	$R_{DSN5}^1$	$V_O = V_{DD}^*(0.5)$	20		60	$\Omega$
Output High Voltage	$V_{OH5}$	$I_{OH} = 1\text{ mA}$	2.4			V
Output Low Voltage	$V_{OL5}$	$I_{OL} = -1\text{ mA}$			0.4	V
Output High Current	$I_{OH5}$	$V_{OH@MIN} = 1\text{ V}$ , $V_{OH@MAX} = 3.135\text{ V}$	-29		-23	mA
Output Low Current	$I_{OL5}$	$V_{OL@MIN} = 1.95\text{ V}$ , $V_{OL@MAX} = 0.4\text{ V}$	29		27	mA
Rise Time	$t_{r5}^1$	$V_{OL} = 0.4\text{ V}$ , $V_{OH} = 2.4\text{ V}$			4	ns
Fall Time	$t_{f5}^1$	$V_{OH} = 2.4\text{ V}$ , $V_{OL} = 0.4\text{ V}$			4	ns
Duty Cycle	$d_{t5}^1$	$V_T = 1.5\text{ V}$	45		55	%
Skew	$T_{sk}$	$V_T = 1.5\text{ V}$			250	ps
Jitter	$t_{jyc-cyc}^1$	$V_T = 1.5\text{ V}$ ; Fixed Clocks			500	ps
	$t_{jyc-cyc}^1$	$V_T = 1.5\text{ V}$ ; Ref Clocks			1000	ps

<sup>1</sup>Guaranteed by design, not 100% tested in production.



## General I<sup>2</sup>C serial interface information

The information in this section assumes familiarity with I<sup>2</sup>C programming. For more information, contact ICS for an I<sup>2</sup>C programming application note.

### How to Write:

- Controller (host) sends a start bit.
- Controller (host) sends the write address D2<sub>(H)</sub>
- ICS clock will *acknowledge*
- Controller (host) sends a dummy command code
- ICS clock will *acknowledge*
- Controller (host) sends a dummy byte count
- ICS clock will *acknowledge*
- Controller (host) starts sending first byte (Byte 0) through byte 5
- ICS clock will *acknowledge* each byte *one at a time*.
- Controller (host) sends a Stop bit

How to Write:	
Controller (Host)	ICS (Slave/Receiver)
Start Bit	
Address D2 <sub>(H)</sub>	
	<b>ACK</b>
Dummy Command Code	
	<b>ACK</b>
Dummy Byte Count	
	<b>ACK</b>
Byte 0	
	<b>ACK</b>
Byte 1	
	<b>ACK</b>
Byte 2	
	<b>ACK</b>
Byte 3	
	<b>ACK</b>
Byte 4	
	<b>ACK</b>
Byte 5	
	<b>ACK</b>
Stop Bit	

### How to Read:

- Controller (host) will send start bit.
- Controller (host) sends the read address D3<sub>(H)</sub>
- ICS clock will *acknowledge*
- ICS clock will send the *byte count*
- Controller (host) acknowledges
- ICS clock sends first byte (*Byte 0*) through *byte 5*
- Controller (host) will need to acknowledge each byte
- Controller (host) will send a stop bit

How to Read:	
Controller (Host)	ICS (Slave/Receiver)
Start Bit	
Address D3 <sub>(H)</sub>	
	<b>ACK</b>
	<b>Byte Count</b>
ACK	
	<b>Byte 0</b>
ACK	
	<b>Byte 1</b>
ACK	
	<b>Byte 2</b>
ACK	
	<b>Byte 3</b>
ACK	
	<b>Byte 4</b>
ACK	
	<b>Byte 5</b>
ACK	
Stop Bit	

### Notes:

1. The ICS clock generator is a slave/receiver, I<sup>2</sup>C component. It can read back the data stored in the latches for verification. **Read-Back will support Intel PIIX4 "Block-Read" protocol.**
2. The data transfer rate supported by this clock generator is 100K bits/sec or less (standard mode)
3. The input is operating at 3.3V logic levels.
4. The data byte format is 8 bit bytes.
5. To simplify the clock generator I<sup>2</sup>C interface, the protocol is set to use only "**Block-Writes**" from the controller. The bytes must be accessed in sequential order from lowest to highest byte with the ability to stop after any complete byte has been transferred. The Command code and Byte count shown above must be sent, but the data is ignored for those two bytes. The data is loaded until a Stop sequence is issued.
6. At power-on, all registers are set to a default condition, as shown.



## Shared Pin Operation - Input/Output Pins

The I/O pins designated by (input/output) on the ICS9248-138 serve as dual signal functions to the device. During initial power-up, they act as input pins. The logic level (voltage) that is present on these pins at this time is read and stored into a 5-bit internal data latch. At the end of Power-On reset, (see AC characteristics for timing values), the device changes the mode of operations for these pins to an output function. In this mode the pins produce the specified buffered clocks to external loads.

To program (load) the internal configuration register for these pins, a resistor is connected to either the VDD (logic 1) power supply or the GND (logic 0) voltage potential. A 10 Kilohm (10K) resistor is used to provide both the solid CMOS programming voltage needed during the power-up programming period and to provide an insignificant load on the output clock during the subsequent operating period.

Figure 1 shows a means of implementing this function when a switch or 2 pin header is used. With no jumper is installed the pin will be pulled high. With the jumper in place the pin will be pulled low. If programmability is not necessary, than only a single resistor is necessary. The programming resistors should be located close to the series termination resistor to minimize the current loop area. It is more important to locate the series termination resistor close to the driver than the programming resistor.

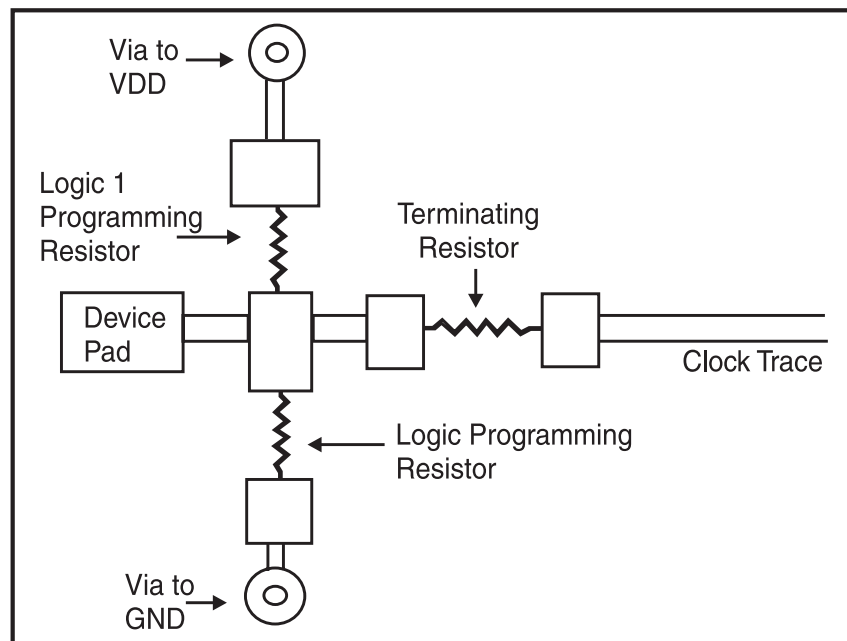

**Fig. 1**



## PD# Timing Diagram

The power down selection is used to put the part into a very low power state without turning off the power to the part. PD# is an asynchronous active low input. This signal needs to be synchronized internal to the device prior to powering down the clock synthesizer.

Internal clocks are not running after the device is put in power down. When PD# is active low all clocks need to be driven to a low value and held prior to turning off the VCOs and crystal. The power up latency needs to be less than 3 mS. The power down latency should be as short as possible but conforming to the sequence requirements shown below. The REF and 48MHz clocks are expected to be stopped in the LOW state as soon as possible. Due to the state of the internal logic, stopping and holding the REF clock outputs in the LOW state may require more than one clock cycle to complete.

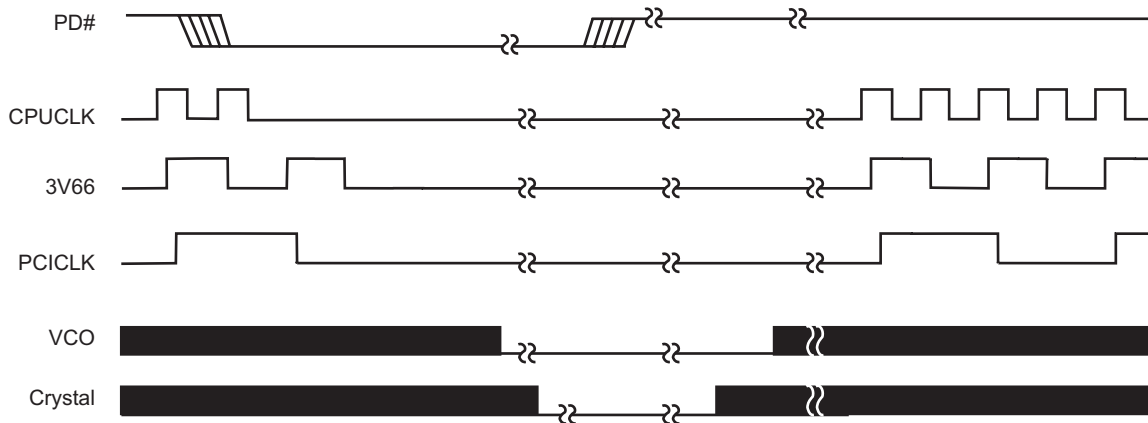

### Notes:

1. All timing is referenced to the Internal CPUCLK (defined as inside the ICS9248 device).
2. As shown, the outputs Stop Low on the next falling edge after PD# goes low.
3. PD# is an asynchronous input and metastable conditions may exist. This signal is synchronized inside this part.
4. The shaded sections on the VCO and the Crystal signals indicate an active clock.
5. Diagrams shown with respect to 133MHz. Similar operation when CPU is 100MHz.

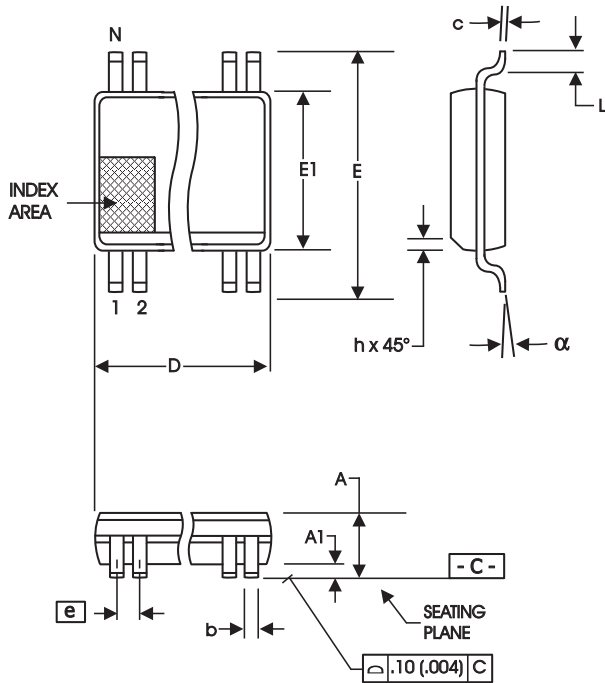

300 mil SSOP

SYMBOL	In Millimeters COMMON DIMENSIONS		In Inches COMMON DIMENSIONS	
	MIN	MAX	MIN	MAX
A	2.41	2.80	.095	.110
A1	0.20	0.40	.008	.016
b	0.20	0.34	.008	.0135
c	0.13	0.25	.005	.010
D	SEE VARIATIONS		SEE VARIATIONS	
E	10.03	10.68	.395	.420
E1	7.40	7.60	.291	.299
e	0.635 BASIC		0.025 BASIC	
h	0.38	0.64	.015	.025
L	0.50	1.02	.020	.040
N	SEE VARIATIONS		SEE VARIATIONS	
a	0°	8°	0°	8°

VARIATIONS

N	D mm.		D (inch)	
	MIN	MAX	MIN	MAX
48	15.75	16.00	.620	.630

Reference Doc.: JEDEC Publication 95, MO-118

10-0034

Ordering Information

9248yF-138

Example:

XXXX y F - PPP - T

- XXXX — Device Type (consists of 3 or 4 digit numbers)
- y — Revision Designator (will not correlate with datasheet revision)
- F — Package Type  
F=SSOP
- PPP — Pattern Number (2 or 3 digit number for parts with ROM code patterns)
- T — Designation for tape and reel packaging

## Looking for pricing, stock, or lifecycle information?

Click below to explore more details on WIN SOURCE:

- ⊖ [View ICS9248BF-138LF on WIN SOURCE](#)
- ⊖ [IDT, Integrated Device Technology Inc Information](#)

## Optimize Your Supply Chain with WIN SOURCE Solutions

- ✓ Global Sourcing Solution
- ✓ Obsolete Management
- ✓ Cost Control Management
- ✓ Shortage Management
- ✓ Alternative Solution
- ✓ Excess Inventory Management