

**32-Bit**

Microcontroller

**TC38x**

32-Bit Single-Chip Microcontroller  
AD/AE-Step

**32-Bit Single-Chip Microcontroller**

**Data Sheet**

V 1.2, 2021-03

**Microcontroller**

**Edition 2021-03**

**Published by  
Infineon Technologies AG  
81726 Munich, Germany**

**© 2021 Infineon Technologies AG  
All Rights Reserved.**

### **Legal Disclaimer**

The information given in this document shall in no event be regarded as a guarantee of conditions or characteristics. With respect to any examples or hints given herein, any typical values stated herein and/or any information regarding the application of the device, Infineon Technologies hereby disclaims any and all warranties and liabilities of any kind, including without limitation, warranties of non-infringement of intellectual property rights of any third party.

### **Information**

For further information on technology, delivery terms and conditions and prices, please contact the nearest Infineon Technologies Office ([www.infineon.com](http://www.infineon.com))

### **Warnings**

Due to technical requirements, components may contain dangerous substances. For information on the types in question, please contact the nearest Infineon Technologies Office.

Infineon Technologies components may be used in life-support devices or systems only with the express written approval of Infineon Technologies, if a failure of such components can reasonably be expected to cause the failure of that life-support device or system or to affect the safety or effectiveness of that device or system. Life support devices or systems are intended to be implanted in the human body or to support and/or maintain and sustain and/or protect human life. If they fail, it is reasonable to assume that the health of the user or other persons may be endangered.

---

**Revision History**

<b>Page or Item</b>	<b>Subjects (major changes since previous revision)</b>
<b>V 0.4, 2017-02</b>	
	Version 0.4 is the first version of this document
<b>V 0.6, 2017-06</b>	
	The history is documented in the last chapter
<b>V 0.7, 2018-05</b>	
	The history is documented in the last chapter
<b>V 0.71, 2018-07</b>	
	The history is documented in the last chapter
<b>V 1.0, 2018-09</b>	
	The history is documented in the last chapter
<b>V 1.1, 2019-09</b>	
	The history is documented in the last chapter
<b>V 1.2, 2021-03</b>	
	The history is documented in the last chapter

**Trademarks of Infineon Technologies AG**

AURIX™, C166™, CanPAK™, CIPOS™, CIPURSE™, EconoPACK™, CoolMOS™, CoolSET™, CORECONTROL™, CROSSAVE™, DAVE™, DI-POL™, EasyPIM™, EconoBRIDGE™, EconoDUAL™, EconoPIM™, EconoPACK™, EiceDRIVER™, eupec™, FCOS™, HITFET™, HybridPACK™, I<sup>2</sup>RF™, ISOFACE™, IsoPACK™, MIPAK™, ModSTACK™, my-d™, NovalithIC™, OptiMOS™, ORIGA™, POWERCODE™, PRIMARION™, PrimePACK™, PrimeSTACK™, PRO-SIL™, PROFET™, RASIC™, ReverSave™, SatRIC™, SIEGET™, SINDRION™, SIPMOS™, SmartLEWIS™, SOLID FLASH™, TEMPFET™, thinQ!™, TRENCHSTOP™, TriCore™.

**Other Trademarks**

Advance Design System™ (ADS) of Agilent Technologies, AMBA™, ARM™, MULTI-ICE™, KEIL™, PRIMECELL™, REALVIEW™, THUMB™,  $\mu$ Vision™ of ARM Limited, UK. AUTOSAR™ is licensed by AUTOSAR development partnership. Bluetooth™ of Bluetooth SIG Inc. CAT-iq™ of DECT Forum. COLOSSUS™, FirstGPS™ of Trimble Navigation Ltd. EMV™ of EMVCo, LLC (Visa Holdings Inc.). EPCOS™ of Epcos AG. FLEXGO™ of Microsoft Corporation. FlexRay™ is licensed by FlexRay Consortium. HYPERTERMINAL™ of Hilgraeve Incorporated. IEC™ of Commission Electrotechnique Internationale. IrDA™ of Infrared Data Association Corporation. ISO™ of INTERNATIONAL ORGANIZATION FOR STANDARDIZATION. MATLAB™ of MathWorks, Inc. MAXIM™ of Maxim Integrated Products, Inc. MICROTEC™, NUCLEUS™ of Mentor Graphics Corporation. MIPI™ of MIPI Alliance, Inc. MIPS™ of MIPS Technologies, Inc., USA. muRata™ of MURATA MANUFACTURING CO., MICROWAVE OFFICE™ (MWO) of Applied Wave Research Inc., OmniVision™ of OmniVision Technologies, Inc. Openwave™ Openwave Systems Inc. RED HAT™ Red Hat, Inc. RFMD™ RF Micro Devices, Inc. SIRIUS™ of Sirius Satellite Radio Inc. SOLARIS™ of Sun Microsystems, Inc. SPANSION™ of Spansion LLC Ltd. Symbian™ of Symbian Software Limited. TAIYO YUDEN™ of Taiyo Yuden Co. TEAKLITE™ of CEVA, Inc. TEKTRONIX™ of Tektronix Inc. TOKO™ of TOKO KABUSHIKI KAISHA TA. UNIX™ of X/Open Company Limited. VERILOG™, PALLADIUM™ of Cadence Design Systems, Inc. VLYNQ™ of Texas Instruments Incorporated. VXWORKS™, WIND RIVER™ of WIND RIVER SYSTEMS, INC. ZETEX™ of Diodes Zetex Limited.

Last Trademarks Update 2011-11-11

## Table of Contents

<b>1</b>	<b>Summary of Features</b>	<b>7</b>
<b>2</b>	<b>Pin Definition and Functions</b>	<b>12</b>
2.1	BGA516 Package Variant Pin Configuration	14
2.2	BGA292 Package Variant Pin Configuration	160
2.3	Sequence of Pads in Pad Frame	262
2.4	Legend	284
<b>3</b>	<b>Electrical Specification</b>	<b>286</b>
3.1	Parameter Interpretation	286
3.2	Absolute Maximum Ratings	287
3.3	Pin Reliability in Overload	288
3.4	Operating Conditions	291
3.5	5 V / 3.3 V switchable Pads	294
3.6	High performance LVDS Pads	313
3.7	VADC Parameters	316
3.8	DSADC Parameters	320
3.9	MHz Oscillator	323
3.10	Back-up Clock	325
3.11	Temperature Sensor	326
3.12	Power Supply Current	327
3.12.1	Calculating the 1.25 V Current Consumption	331
3.13	Power Supply Infrastructure and Supply Start-up	332
3.13.1	Supply Ramp-up and Ramp-down Behavior	333
3.13.1.1	Single Supply mode (a)	333
3.13.1.2	Single Supply mode (e)	335
3.13.1.3	External Supply mode (d)	337
3.13.1.4	External Supply mode (h)	339
3.14	Reset Timing	341
3.15	PMS	344
3.16	System Phase Locked Loop (SYS_PLL)	352
3.17	Peripheral Phase Locked Loop (PER_PLL)	353
3.18	AC Specifications	354
3.19	JTAG Parameters	355
3.20	DAP Parameters	357
3.21	ASCLIN SPI Master Timing	359
3.22	QSPI Timings, Master and Slave Mode	361
3.23	MSC Timing 5 V Operation	365
3.24	Ethernet Interface (ETH) Characteristics	367
3.24.1	ETH Measurement Reference Points	367
3.24.2	ETH Management Signal Parameters (ETH_MDC, ETH_MDIO)	368
3.24.3	ETH MII Parameters	369
3.24.4	ETH RMII Parameters	370
3.24.5	ETH RGMII Parameters	371
3.25	E-Ray Parameters	372
3.26	HSCT Parameters	374
3.27	Inter-IC (I2C) Interface Timing	375
3.28	FSP Parameters	379
3.29	Flash Target Parameters	380
3.30	Quality Declarations	385

---

3.31	Package Outline .....	387
3.31.1	Package Parameters .....	388
<b>4</b>	<b>History .....</b>	<b>389</b>
4.1	Changes from Version 0.4 to Version 0.6 .....	389
4.2	Changes from Version 0.6 to Version 0.7 .....	398
4.3	Changes from Version 0.7 to Version 0.71 .....	404
4.4	Changes from Version 0.71 to Version 1.0 .....	406
4.5	Changes from Version 1.0 to Version 1.1 .....	411
4.6	Changes from Version 1.1 to Version 1.2 .....	412

## 1 Summary of Features

The TC38x product family has the following features:

- High Performance Microcontroller with four CPU cores
- Four 32-bit super-scalar TriCore CPUs (TC1.6.2P), each having the following features:
  - Superior real-time performance
  - Strong bit handling
  - Fully integrated DSP capabilities
  - Multiply-accumulate unit able to sustain 2 MAC operations per cycle
  - Fully pipelined Floating point unit (FPU)
  - up to 300 MHz operation at full temperature range
  - up to 240/96 Kbyte Data Scratch-Pad RAM (DSPR)
  - up to 64 Kbyte Instruction Scratch-Pad RAM (PSPR)
  - up to 64 Kbyte Data RAM (DLMU)
  - 32 Kbyte Instruction Cache (ICACHE)
  - 16 Kbyte Data Cache (DCACHE)
- Lockstepped shadow cores for two TC1.6.2P
- Multiple on-chip memories
  - All embedded NVM and SRAM are ECC protected
  - up to 10 Mbyte Program Flash Memory (PFLASH)
  - up to 512 Kbyte Data Flash Memory (DFLASH 0) usable for EEPROM emulation
  - 128 Kbyte Memory (LMU)
  - BootROM (BROM)
- 128-Channel DMA Controller with safe data transfer
- Sophisticated interrupt system (ECC protected)
- High performance on-chip bus structure
  - 64-bit Cross Bar Interconnect (SRI) giving fast parallel access between bus masters, CPUs and memories
  - 32-bit System Peripheral Bus (SPB) for on-chip peripheral and functional units
  - SRI to SPB bus bridges (SFI Bridge)
- Optional Hardware Security Module (HSM) on some variants
- Safety Management Unit (SMU) handling safety monitor alarms
- Memory Test Unit with ECC, Memory Initialization and MBIST functions (MTU)
- Hardware I/O Monitor (IOM) for checking of digital I/O
- Versatile On-chip Peripheral Units
  - 24 Asynchronous/Synchronous Serial Channels (ASCLIN) with hardware LIN support (V1.3, V2.0, V2.1 and J2602) up to 50 MBaud
  - 5 Queued SPI Interface Channels (QSPI) with master and slave capability up to 50 Mbit/s
  - 1 High Speed Serial Link (HSSL) for serial inter-processor communication up to 320 Mbit/s
  - 3 serial Micro Second Bus interfaces (MSC) for serial port expansion to external power devices
  - 3 MCMCAN Modules with 4 CAN nodes for high efficiency data handling via FIFO buffering
  - 25 Single Edge Nibble Transmission (SENT) channels for connection to sensors
  - 2 FlexRay™ module with 2 channels (E-Ray) supporting V2.1

---

**Summary of Features**

- One Generic Timer Module (GTM) providing a powerful set of digital signal filtering and timer functionality to realize autonomous and complex Input/Output management
- One Capture / Compare 6 module (Two kernels CCU60 and CCU61)
- One General Purpose 12 Timer Unit (GPT120)
- 4 channel Peripheral Sensor Interface conforming to V1.3 (PSI5)
- 1 Peripheral Sensor Interface with Serial PHY (PSI5-S)
- 2 Inter-Integrated Circuit Bus Interface (I2C) conforming to V2.1
- 1 IEEE802.3 Ethernet MAC with RGMII, RMII and MII interfaces (ETH)
- Versatile Successive Approximation ADC (VADC)
  - Cluster of 16 independent ADC kernels
  - Input voltage range from 0 V to 5.5V (ADC supply)
- Delta-Sigma ADC (DSADC)
  - 10 channels
- Digital programmable I/O ports
- On-chip debug support for OCDS Level 1 (CPUs, DMA, On Chip Buses)
- multi-core debugging, real time tracing, and calibration
- four/five wire JTAG (IEEE 1149.1) or DAP (Device Access Port) interface
- Power Management System and on-chip regulators
- Clock Generation Unit with System PLL and Peripheral PLL
- Embedded Voltage Regulator
- Qualified for automotive application according to AEC-Q100 (only applicable after delivery release of the corresponding sales codes)
- ISO 26262 Safety Element out of Context for safety requirements up to ASIL D (only applicable for sales codes listed within a released Safety Package Release Note from IFX)

**Ordering Information**

The ordering code for Infineon microcontrollers provides an exact reference to the required product. This ordering code identifies:

- The derivative itself, i.e. its function set, the temperature range, and the supply voltage
- The package and the type of delivery.

**Table 1-1 Platform Feature Overview**

<b>Feature</b>		<b>TC38x</b>
CPUs	Type	TC1.6.2
	Cores / Checker Cores	4 / 2
	Max. Freq.	300 MHz
Cache per CPU	Program	32 KB
	Data	16 KB
SRAM per CPU	PSPR	64 KB
	DSPR	240 KB for CPU0,1 / 96 KB else
	DLMU	64 KB
SRAM global	LMU	128 KB
	DAM	64 KB
Extension Memory	TCM	- MB
	XCM	- MB
	XTM	- KB
Program Flash	Size	10 MB
	Banks	3 x 3 MB, 1 x 1 MB
Data Flash	Size (single-ended)	512 KB (DF0) + 128 KB (DF1)
DMA	Channels	128
CONVCTRL	Modules	1
EVADC	Primary Groups/Channels	8 / 64
	Secondary Groups/Channels	4 / 64
	Fast Compare Channels	4
EDSADC	Channels	10

**Table 1-1 Platform Feature Overview (cont'd)**

Feature		TC38x
GTM	Clusters	9 (5 @ 200MHz, 4 @ 100MHz)
	TIM (8 ch)	7
	TOM (16 ch)	5
	ATOM (8 ch)	9
	MCS (8 ch)	7
	CMU / ICM	1 / 1
	PSM	2
	TBU channels <sup>1)</sup>	4 (TBU0-3)
	SPE	4
	CMP / MON	1 / 1
	BRC / DPLL	1 / 1
	CDTM modules	6
	DTM modules	20 (8 on TOM, 12 on ATOM)
Timer	GPT12	1
	CCU6	1
STM	Modules	4
FlexRay	Modules	2
	Channels	2
CAN	Modules	3
	Nodes	3 x 4
	of which support TT-CAN	1
QSPI	Modules	5
	HSCI Channels	-
ASCLIN	Modules	24
I2C	Interfaces	2
SENT	Channels	25
PSI5	Modules	4
PSI5-S	Modules	1
HSSL	Channels	1
MSC	Channels	3
SDMMC	eMMC/SD Interface	0
Ethernet (10/100Mbit/1Gbit)	Modules	1
FCE	Modules	1
Safety Support	SMU	yes
	IOM	yes
SPU	Modules	-
RIF	Modules	-
HSPDM	Modules	-

**Table 1-1 Platform Feature Overview (cont'd)**

Feature		TC38x
Security	HSM+	1
Debug	OCDS	yes
	MCDS	no
	miniMCDS	yes
	miniMCDS TRAM	8 KB
	AGBT	No
Low Power Features	Standby RAM	2
	SCR	yes
Packages	Type	FBGA-516 / LFBGA-292
I/O	Type	5 V CMOS / 3.3 V CMOS / LVDS
T <sub>ambient</sub>	Range	-40 ... +150°C

1) TBU3 has special purpose as angle clock.

## 2 Pin Definition and Functions

The following figures are showing the Logic Symbols for the package variants:

- BGA516 (Figure 2-1)
- BGA292 (Figure 2-2)

	1	2	3	4	5	6	7	8	9	10	11	12	13	14	15	16	17	18	19	20	21	22	23	24	25	26	27	28	29	30		
A	NC1	VEXT	NC	NC	P10.15	P10.13	P10.11	NC	NC	NC	P13.15	P13.13	P13.11	P13.9	P13.7	P13.5	NC	P14.15	P14.13	P14.11	NC	P15.15	P15.13	P15.11	NC	NC	NC	NC	VDDP3	VSS	A	
B	NC	VSS	VEXT	NC	P10.14	NC	P10.10	P10.9	NC	NC	P13.14	P13.12	P13.10	NC	P13.6	P13.4	NC	P14.14	P14.12	NC	NC	P15.14	P15.12	P15.10	NC	NC	NC	VDDP3	VSS	VSS	B	
C	NC	NC																												NC	NC	C
D	NC	NC																												NC	NC	D
E	NC	NC																												NC	NC	E
F	P02.13	P02.12																											NC	NC	F	
G	P02.15	P02.14																											NC	NC	G	
H	NC	NC																											VSS	VSS	H	
J	NC	P01.0																											VEXT	VEXT	J	
K	P01.1	P01.2																											P24.14	P24.15	K	
L	P01.8	P01.9																											P24.12	P24.13	L	
M	P01.11	P01.10																											P24.10	P24.11	M	
N	P01.13	P01.12																											P24.8	P24.9	N	
P	P01.15	P01.14																											P24.6	P24.7	P	
R	NC	NC																											P24.4	P24.5	R	
T	NC	P00.13																											P24.2	P24.3	T	
U	P00.15	P00.14																											P24.0	P24.1	U	
V	NC	NC																											NC1	NC1	V	
W	AN70 / P41.2	AN71 / P41.3																											P25.6	NC	W	
Y	AN88 / P41.0	AN89 / P41.1																											P25.14	P25.15	Y	
AA	AN87 / P40.15	AN86																											P25.12	P25.13	AA	
AB	AN85	AN84 / P41.8																											P25.10	P25.11	AB	
AC	AN83 / P41.7	AN82 / P41.6																											P25.8	P25.9	AC	
AD	AN80	AN81																											P25.7	P25.5	AD	
AE	AN59	AN58																											P25.4	P25.3	AE	
AF	AN56	AN57																											P25.2	P25.1	AF	
AG	VAREF3	VAGND3																											P26.0	P25.0	AG	
AH	NC	NC																											VEXT	VEXT	AH	
AJ	NC	NC	NC	AN54 / P41.4	AN52	AN50	AN49	VSSM	VDDM	VSS	VEXT	P31.0	P31.2	P31.4	P31.6	P31.8	P31.10	P31.12	P31.14	NC	P30.0	P30.2	P30.4	P30.6	P30.8	P30.10	P30.12	P30.14	VSS	VEXT	AJ	
AK	NC1	NC	NC	AN55 / P41.5	AN53	AN51	AN48	VSSM	VDDM	VSS	VEXT	P31.1	P31.3	P31.5	P31.7	P31.9	P31.11	P31.13	P31.15	VEXT	P30.1	P30.3	P30.5	P30.7	P30.9	P30.11	P30.13	P30.15	VEXT	VSS	AK	

TC38xpd - (top view)

Figure 2-1 Logic Symbol for the package variant BGA516

Pin Definition and Functions

	1	2	3	4	5	6	7	8	9	10	11	12	13	14	15	16	17	18	19	20
A	NC1	VEXT	P10.7	P10.6	P10.2	P10.3	P10.0	P11.11	P11.9	P11.2	P13.3	P13.1	P14.8	P14.5	P14.1	P15.6	P15.4	P15.1	VDDP3	VSS
B	P02.0	VSS	VEXT	P10.8	P10.5	P10.4	P10.1	P11.12	P11.10	P11.3	P13.2	P13.0	P14.6	P14.3	P14.4	P14.0	P15.3	VDDP3	VSS	P15.0
C	P02.2	P02.1																	P15.2	P20.14
D	P02.4	P02.3		VSS	VFLEX	P11.15	P11.14	P11.5	P11.6	P11.4	P14.10	P14.9	P14.7	P15.8	P15.7	VDD	VSS		P20.12	P20.13
E	P02.6	P02.5		P02.9	VSS	P11.13	P11.8	P11.7	P11.1	P11.0	P12.1	P12.0	P14.2	P15.5	VDD	VSS	P20.9		P20.10	P20.11
F	P02.8	P02.7		P02.11	P02.10											ESR0	P20.6		P20.7	P20.8
G	P00.0	P00.1		P01.4	P01.3			VDD	VSS	VSS	VSS	VSS	VDD			ESR1	PORST		P20.1	P20.3
H	P00.2	P00.3		P01.6	P01.5		VDD		VSS	VSS	VSS	VSS		VDD		P21.7 / TDO	P21.6 / TDI		P20.2	P20.0
J	P00.4	P00.5		P00.6	P01.7		VSS	VSS		VSS	VSS		VSS	VSS		TCK	P21.1		P21.3	P21.5
K	P00.7	P00.9		P00.8	P00.10		VSS	VSS	VSS	VSS	VSS	VSS	VSS	NC		TMS	P21.0		P21.2	P21.4
L	P00.11	P00.12		AN43	AN42		VSS	VSS	VSS	VSS	VSS	VSS	VSS	VSS		P22.10	P22.11		TRST	VSS
M	AN46	AN47		AN41	AN40		VSS	VSS		VSS	VSS		VSS	VSS		P22.8	P22.9		XTAL2	XTAL1
N	AN44	AN45		AN36 / P40.6	AN38 / P40.8		VDD		VSS	VSS	VSS	VSS		VDD		P22.6	P22.7		VDD	VEXT
P	AN39 / P40.9	AN37 / P40.7		AN32 / P40.4	AN34		VDD	VSS	VSS	VSS	VSS	VDD				P22.4	P22.5		P22.1	P22.0
R	AN33 / P40.5	AN35		AN31	AN23											P23.7	P23.6		P22.3	P22.2
T	VAREF 2	VAGND 2		AN30	AN22	AN15	AN12	AN6	AN4	AN0	VEVRS B	P34.2	P34.4	P33.14	P32.5	VSS	P23.5		P23.3	P23.4
U	AN29 / P40.14	AN28 / P40.13		NC1	AN17 / P40.10	AN14	AN9	AN7	AN3	AN1	P34.1	P34.3	P34.5	P33.15	P32.6	P32.7	VSS		P23.1	P23.2
V	AN27 / P40.3	AN26 / P40.2																	VEXT	P23.0
W	AN25 / P40.1	AN24 / P40.0	AN19 / P40.12	AN18 / P40.11	AN16	AN13	AN11	AN8	AN2	P33.0	P33.2	P33.4	P33.6	P33.8	P33.10	P33.12	P32.1 / VGATE 1P	P32.4	VSS	VEXT
Y	NC1	AN21	AN20	VSSM	VDDM	VAREF 1	VAGND 1	AN10	AN5	P33.1	P33.3	P33.5	P33.7	P33.9	P33.11	P33.13	P32.0 / VGATE 1N	P32.2	P32.3	VSS

TC38xpd - (top view)

Figure 2-2 Logic Symbol for the package variant BGA292

## 2.1 BGA516 Package Variant Pin Configuration

**Table 2-1 Port 00 Functions**

Ball	Symbol	Ctrl.	Buffer Type	Function
M6	P00.0	I	FAST / PU1 / VEXT / ES	General-purpose input
	GTM_TIM5_IN4_10			Mux input channel 4 of TIM module 5
	GTM_TIM3_IN0_1			Mux input channel 0 of TIM module 3
	GTM_TIM2_IN0_1			Mux input channel 0 of TIM module 2
	CCU61_CTRAPA			Trap input capture
	CCU60_T12HRE			External timer start 12
	MSC0_INJ0			Injection signal from port
	GETH_MDIOA			MDIO Input
	P00.0	O0		General-purpose output
	GTM_TOUT9	O1	GTM muxed output	
	IOM_REF0_9		Reference input 0	
	ASCLIN3_ASCLK	O2	Shift clock output	
	ASCLIN3_ATX	O3	Transmit output	
	IOM_MON2_15		Monitor input 2	
	IOM_REF2_15		Reference input 2	
	—	O4	Reserved	
	CAN10_TXD	O5	CAN transmit output node 0	
	—	O6	Reserved	
	CCU60_COUT63	O7	T13 PWM channel 63	
	IOM_MON1_6		Monitor input 1	
IOM_REF1_0		Reference input 1		
GETH_MDIO	O	MDIO Output		

## Pin Definition and Functions BGA516 Package Variant Pin Configuration

Table 2-1 Port 00 Functions (cont'd)

Ball	Symbol	Ctrl.	Buffer Type	Function
M7	P00.1	I	SLOW / PU1 / VEXT / ES	General-purpose input
	GTM_TIM5_IN5_11			Mux input channel 5 of TIM module 5
	GTM_TIM3_IN1_1			Mux input channel 1 of TIM module 3
	GTM_TIM2_IN1_1			Mux input channel 1 of TIM module 2
	CCU60_CC60INB			T12 capture input 60
	ASCLIN3_ARXE			Receive input
	EDSADC_DSCIN5A			Modulator clock input, channel 5
	CAN10_RXDA			CAN receive input node 0
	PSI5_RX0A			RXD inputs (receive data) channel 0
	CCU61_CC60INA			T12 capture input 60
	SENT_SENT0B			Receive input channel 0
	EDSADC_DSCIN7B			Modulator clock input, channel 7
	EVADC_G9CH11			AI
	EDSADC_EDS5NA		Negative analog input channel 5, pin A	
	P00.1	O0	General-purpose output	
	GTM_TOUT10	O1	GTM muxed output	
	IOM_REF0_10		Reference input 0	
	ASCLIN3_ATX	O2	Transmit output	
	IOM_MON2_15		Monitor input 2	
	IOM_REF2_15		Reference input 2	
	—	O3	Reserved	
	EDSADC_DSCOUT5	O4	Modulator clock output	
	EDSADC_DSCOUT7	O5	Modulator clock output	
	SENT_SPC0	O6	Transmit output	
	CCU61_CC60	O7	T12 PWM channel 60	
	IOM_MON1_8		Monitor input 1	
IOM_REF1_13		Reference input 1		

## Pin Definition and Functions BGA516 Package Variant Pin Configuration

Table 2-1 Port 00 Functions (cont'd)

Ball	Symbol	Ctrl.	Buffer Type	Function
N6	P00.2	I	SLOW / PU1 / VEXT / ES1	General-purpose input
	GTM_TIM5_IN6_11			Mux input channel 6 of TIM module 5
	GTM_TIM3_IN1_2			Mux input channel 1 of TIM module 3
	GTM_TIM2_IN1_2			Mux input channel 1 of TIM module 2
	EDSADC_DSDIN7B			Digital datastream input, channel 7
	EDSADC_DSDIN5A			Digital datastream input, channel 5
	SENT_SENT1B			Receive input channel 1
	EVADC_G9CH10	AI		Analog input channel 10, group 9
	EDSADC_EDS5PA			Positive analog input channel 5, pin A
	P00.2	O0		General-purpose output
	GTM_TOUT11	O1		GTM muxed output
	IOM_REF0_11			Reference input 0
	ASCLIN3_ASCLK	O2		Shift clock output
	CAN21_TXD	O3		CAN transmit output node 1
	PSI5_TX0	O4		TXD outputs (send data)
	IOM_MON1_14			Monitor input 1
	IOM_REF1_14			Reference input 1
	CAN03_TXD	O5		CAN transmit output node 3
	IOM_MON2_8			Monitor input 2
	IOM_REF2_8			Reference input 2
	QSPI3_SLSO4	O6		Master slave select output
	CCU61_COUT60	O7		T12 PWM channel 60
	IOM_MON1_11			Monitor input 1
	IOM_REF1_10			Reference input 1

## Pin Definition and Functions BGA516 Package Variant Pin Configuration

Table 2-1 Port 00 Functions (cont'd)

Ball	Symbol	Ctrl.	Buffer Type	Function
N7	P00.3	I	SLOW / PU1 / VEXT / ES1	General-purpose input
	GTM_TIM5_IN7_10			Mux input channel 7 of TIM module 5
	GTM_TIM3_IN2_1			Mux input channel 2 of TIM module 3
	GTM_TIM2_IN2_1			Mux input channel 2 of TIM module 2
	CCU60_CC61INB			T12 capture input 61
	EDSADC_DSCIN3A			Modulator clock input, channel 3
	EDSADC_ITR5F			Trigger/Gate input, channel 5
	PSI5_RX1A			RXD inputs (receive data) channel 1
	CAN03_RXDA			CAN receive input node 3
	CAN21_RXDA			CAN receive input node 1
	PSI5S_RXA			RX data input
	SENT_SENT2B			Receive input channel 2
	CCU61_CC61INA			T12 capture input 61
	ASCLIN12_ARXA			Receive input
	EVADC_G9CH9	AI	Analog input channel 9, group 9	
	EDSADC_EDS5NB		Negative analog input channel 5, pin B	
	P00.3	O0	General-purpose output	
	GTM_TOUT12	O1	GTM muxed output	
	IOM_REF0_12		Reference input 0	
	ASCLIN3_ASLSO	O2	Slave select signal output	
ASCLIN12_ATX	O3	Transmit output		
EDSADC_DSCOUT3	O4	Modulator clock output		
—	O5	Reserved		
SENT_SPC2	O6	Transmit output		
CCU61_CC61	O7	T12 PWM channel 61		
IOM_MON1_9		Monitor input 1		
IOM_REF1_12		Reference input 1		

## Pin Definition and Functions BGA516 Package Variant Pin Configuration

Table 2-1 Port 00 Functions (cont'd)

Ball	Symbol	Ctrl.	Buffer Type	Function	
P6	P00.4	I	SLOW / PU1 / VEXT / ES1	General-purpose input	
	GTM_TIM6_IN4_1			Mux input channel 4 of TIM module 6	
	GTM_TIM3_IN3_1			Mux input channel 3 of TIM module 3	
	GTM_TIM2_IN3_1			Mux input channel 3 of TIM module 2	
	SCU_E_REQ2_2			ERU Channel 2 inputs 0 to 5 (0 is the LSB and 5 is the MSB)	
	SENT_SENT3B			Receive input channel 3	
	EDSADC_DSDIN3A			Digital datastream input, channel 3	
	EDSADC_SGNA			Carrier sign signal input	
	ASCLIN10_ARXA			Receive input	
	GTM_DTMA5_0			CDTM5_DTM4	
	GTM_DTMT3_0			CDTM3_DTM0	
	EVADC_G9CH8			AI	Analog input channel 8, group 9
	EDSADC_EDS5PB				Positive analog input channel 5, pin B
	P00.4	O0	General-purpose output		
	GTM_TOUT13	O1	GTM muxed output		
	IOM_REF0_13		Reference input 0		
	PSI5S_TX	O2	TX data output		
	CAN11_TXD	O3	CAN transmit output node 1		
	PSI5_TX1	O4	TXD outputs (send data)		
	IOM_MON1_15		Monitor input 1		
	—	O5	Reserved		
	SENT_SPC3	O6	Transmit output		
	CCU61_COUT61	O7	T12 PWM channel 61		
IOM_MON1_12		Monitor input 1			
IOM_REF1_9		Reference input 1			

## Pin Definition and Functions BGA516 Package Variant Pin Configuration

Table 2-1 Port 00 Functions (cont'd)

Ball	Symbol	Ctrl.	Buffer Type	Function
P7	P00.5	I	SLOW / PU1 / VEXT / ES1	General-purpose input
	GTM_TIM3_IN4_1			Mux input channel 4 of TIM module 3
	GTM_TIM3_IN0_11			Mux input channel 0 of TIM module 3
	GTM_TIM2_IN4_1			Mux input channel 4 of TIM module 2
	CCU60_CC62INB			T12 capture input 62
	EDSADC_DSCIN2A			Modulator clock input, channel 2
	PSI5_RX2A			RXD inputs (receive data) channel 2
	CCU61_CC62INA			T12 capture input 62
	SENT_SENT4B			Receive input channel 4
	CAN11_RXDB			CAN receive input node 1
	ASCLIN12_ARXB			Receive input
	GTM_DTMT1_1			CDTM1_DTM0
	EVADC_G9CH7			AI
	P00.5	O0	General-purpose output	
	GTM_TOUT14	O1	GTM muxed output	
	IOM_REF0_14		Reference input 0	
	EDSADC_CGPWMN	O2	Negative carrier generator output	
	QSPI3_SLSO3	O3	Master slave select output	
	EDSADC_DSCOUT2	O4	Modulator clock output	
	EVADC_FC0BFLOUT	O5	Boundary flag output, FC channel 0	
	SENT_SPC4	O6	Transmit output	
CCU61_CC62	O7	T12 PWM channel 62		
IOM_MON1_10		Monitor input 1		
IOM_REF1_11		Reference input 1		

## Pin Definition and Functions BGA516 Package Variant Pin Configuration

Table 2-1 Port 00 Functions (cont'd)

Ball	Symbol	Ctrl.	Buffer Type	Function
P9	P00.6	I	SLOW / PU1 / VEXT / ES1	General-purpose input
	GTM_TIM3_IN5_1			Mux input channel 5 of TIM module 3
	GTM_TIM3_IN1_14			Mux input channel 1 of TIM module 3
	GTM_TIM2_IN5_1			Mux input channel 5 of TIM module 2
	EDSADC_ITR4F			Trigger/Gate input, channel 4
	EDSADC_DSDIN2A			Digital datastream input, channel 2
	SENT_SENT5B			Receive input channel 5
	ASCLIN5_ARXA			Receive input
	GTM_DTMT3_1			CDTM3_DTM0
	EVADC_G9CH6			AI
	P00.6	O0	General-purpose output	
	GTM_TOUT15	O1	GTM muxed output	
	IOM_REF0_15		Reference input 0	
	EDSADC_CGPWMP	O2	Positive carrier generator output	
	—	O3	Reserved	
	PSI5_TX2	O4	TXD outputs (send data)	
	IOM_REF1_15		Reference input 1	
	EVADC_EMUX10	O5	Control of external analog multiplexer interface 1	
	SENT_SPC5	O6	Transmit output	
	CCU61_COUT62	O7	T12 PWM channel 62	
IOM_MON1_13		Monitor input 1		
IOM_REF1_8		Reference input 1		

## Pin Definition and Functions BGA516 Package Variant Pin Configuration

Table 2-1 Port 00 Functions (cont'd)

Ball	Symbol	Ctrl.	Buffer Type	Function
R6	P00.7	I	SLOW / PU1 / VEXT / ES1	General-purpose input
	GTM_TIM3_IN6_1			Mux input channel 6 of TIM module 3
	GTM_TIM3_IN2_11			Mux input channel 2 of TIM module 3
	GTM_TIM2_IN6_1			Mux input channel 6 of TIM module 2
	CCU61_CC60INC			T12 capture input 60
	SENT_SENT6B			Receive input channel 6
	EDSADC_DSCIN4A			Modulator clock input, channel 4
	GPT120_T2INA			Trigger/gate input of timer T2
	CCU61_CCPOS0A			Hall capture input 0
	CCU60_T12HRB			External timer start 12
	GTM_DTMT0_2			CDTM0_DTM0
	EVADC_G9CH5			AI
	EDSADC_EDS4NA		Negative analog input channel 4, pin A	
	P00.7	O0	General-purpose output	
	GTM_TOUT16	O1	GTM muxed output	
	ASCLIN5_ATX	O2	Transmit output	
	EVADC_FC2BFLOUT	O3	Boundary flag output, FC channel 2	
	EDSADC_DSCOUT4	O4	Modulator clock output	
	EVADC_EMUX11	O5	Control of external analog multiplexer interface 1	
	SENT_SPC6	O6	Transmit output	
CCU61_CC60	O7	T12 PWM channel 60		
IOM_MON1_8		Monitor input 1		
IOM_REF1_13		Reference input 1		

## Pin Definition and Functions BGA516 Package Variant Pin Configuration

Table 2-1 Port 00 Functions (cont'd)

Ball	Symbol	Ctrl.	Buffer Type	Function	
R9	P00.8	I	SLOW / PU1 / VEXT / ES1	General-purpose input	
	GTM_TIM3_IN7_1			Mux input channel 7 of TIM module 3	
	GTM_TIM3_IN3_11			Mux input channel 3 of TIM module 3	
	GTM_TIM2_IN7_1			Mux input channel 7 of TIM module 2	
	CCU61_CC61INC			T12 capture input 61	
	SENT_SENT7B			Receive input channel 7	
	EDSADC_DSDIN4A			Digital datastream input, channel 4	
	GPT120_T2EUDA			Count direction control input of timer T2	
	CCU61_CCPOS1A			Hall capture input 1	
	CCU60_T13HRB			External timer start 13	
	ASCLIN10_ARXB			Receive input	
	EVADC_G9CH4			AI	Analog input channel 4, group 9
	EDSADC_EDS4PA				Positive analog input channel 4, pin A
	P00.8	O0	General-purpose output		
	GTM_TOUT17	O1	GTM muxed output		
	QSPI3_SLSO6	O2	Master slave select output		
	ASCLIN10_ATX	O3	Transmit output		
	—	O4	Reserved		
	EVADC_EMUX12	O5	Control of external analog multiplexer interface 1		
	SENT_SPC7	O6	Transmit output		
	CCU61_CC61	O7	T12 PWM channel 61		
IOM_MON1_9		Monitor input 1			
IOM_REF1_12		Reference input 1			

## Pin Definition and Functions BGA516 Package Variant Pin Configuration

Table 2-1 Port 00 Functions (cont'd)

Ball	Symbol	Ctrl.	Buffer Type	Function
R7	P00.9	I	SLOW / PU1 / VEXT / ES1	General-purpose input
	GTM_TIM4_IN0_7			Mux input channel 0 of TIM module 4
	GTM_TIM1_IN0_1			Mux input channel 0 of TIM module 1
	GTM_TIM0_IN0_1			Mux input channel 0 of TIM module 0
	CCU61_CC62INC			T12 capture input 62
	SENT_SENT8B			Receive input channel 8
	CCU61_CCPOS2A			Hall capture input 2
	EDSADC_DSCIN1A			Modulator clock input, channel 1
	EDSADC_ITR3F			Trigger/Gate input, channel 3
	GPT120_T4EUDA			Count direction control input of timer T4
	CCU60_T13HRC			External timer start 13
	CCU60_T12HRC			External timer start 12
	ASCLIN13_ARXA			Receive input
	EVADC_G9CH3			AI
	EDSADC_EDS4NB		Negative analog input channel 4, pin B	
	P00.9	O0	General-purpose output	
	GTM_TOUT18	O1	GTM muxed output	
	QSPI3_SLSO7	O2	Master slave select output	
	ASCLIN3_ARTS	O3	Ready to send output	
	EDSADC_DSCOUT1	O4	Modulator clock output	
	ASCLIN4_ATX	O5	Transmit output	
	SENT_SPC8	O6	Transmit output	
	CCU61_CC62	O7	T12 PWM channel 62	
IOM_MON1_10		Monitor input 1		
IOM_REF1_11		Reference input 1		

## Pin Definition and Functions BGA516 Package Variant Pin Configuration

Table 2-1 Port 00 Functions (cont'd)

Ball	Symbol	Ctrl.	Buffer Type	Function
R10	P00.10	I	SLOW / PU1 / VEXT / ES1	General-purpose input
	GTM_TIM4_IN1_11			Mux input channel 1 of TIM module 4
	GTM_TIM1_IN1_1			Mux input channel 1 of TIM module 1
	GTM_TIM0_IN1_1			Mux input channel 1 of TIM module 0
	SENT_SENT9B			Receive input channel 9
	EDSADC_DSDIN1A			Digital datastream input, channel 1
	EVADC_G9CH2			Analog input channel 2, group 9
	EDSADC_EDS4PB	AI	Positive analog input channel 4, pin B	
	P00.10	O0	General-purpose output	
	GTM_TOUT19	O1	GTM muxed output	
	ASCLIN4_ASCLK	O2	Shift clock output	
	ASCLIN13_ATX	O3	Transmit output	
	—	O4	Reserved	
	—	O5	Reserved	
	SENT_SPC9	O6	Transmit output	
	CCU61_COUT63	O7	T13 PWM channel 63	
	IOM_MON1_7		Monitor input 1	
IOM_REF1_7		Reference input 1		
T6	P00.11	I	SLOW / PU1 / VEXT / ES1	General-purpose input
	GTM_TIM4_IN2_11			Mux input channel 2 of TIM module 4
	GTM_TIM1_IN2_1			Mux input channel 2 of TIM module 1
	GTM_TIM0_IN2_1			Mux input channel 2 of TIM module 0
	CCU60_CTRAPA			Trap input capture
	EDSADC_DSCIN0A			Modulator clock input, channel 0
	CCU61_T12HRE			External timer start 12
	SENT_SENT10B	Receive input channel 10		
	ASCLIN13_ARXB	Receive input		
	EVADC_G9CH1	AI	Analog input channel 1, group 9	
	EVADC_FC3CH0		Analog input FC channel 3	
	P00.11	O0	General-purpose output	
	GTM_TOUT20	O1	GTM muxed output	
	ASCLIN4_ASLSO	O2	Slave select signal output	
	ASCLIN13_ATX	O3	Transmit output	
	EDSADC_DSCOUT0	O4	Modulator clock output	
	—	O5	Reserved	
—	O6	Reserved		
—	O7	Reserved		

## Pin Definition and Functions BGA516 Package Variant Pin Configuration

Table 2-1 Port 00 Functions (cont'd)

Ball	Symbol	Ctrl.	Buffer Type	Function
T7	P00.12	I	SLOW / PU1 / VEXT / ES1	General-purpose input
	GTM_TIM4_IN3_11			Mux input channel 3 of TIM module 4
	GTM_TIM1_IN3_1			Mux input channel 3 of TIM module 1
	GTM_TIM0_IN3_1			Mux input channel 3 of TIM module 0
	ASCLIN3_ACTSA			Clear to send input
	EDSADC_DSDIN0A			Digital datastream input, channel 0
	ASCLIN4_ARXA			Receive input
	SENT_SENT11B			Receive input channel 11
	EVADC_G9CH0			AI
	EVADC_FC2CH0	Analog input FC channel 2		
	P00.12	O0	General-purpose output	
	GTM_TOUT21	O1	GTM muxed output	
	—	O2	Reserved	
	—	O3	Reserved	
	—	O4	Reserved	
	—	O5	Reserved	
	—	O6	Reserved	
	CCU61_COUT63	O7	T13 PWM channel 63	
	IOM_MON1_7		Monitor input 1	
IOM_REF1_7	Reference input 1			
T2	P00.13	I	FAST / PU1 / VEXT / ES	General-purpose input
	GTM_TIM6_IN5_2			Mux input channel 5 of TIM module 6
	GTM_TIM5_IN0_1			Mux input channel 0 of TIM module 5
	GTM_TIM4_IN0_1			Mux input channel 0 of TIM module 4
	EDSADC_DSDIN6A			Digital datastream input, channel 6
	P00.13	O0	General-purpose output	
	GTM_TOUT167	O1	GTM muxed output	
	—	O2	Reserved	
	—	O3	Reserved	
	CCU_EXTCLK1	O4	External Clock 1	
	—	O5	Reserved	
	—	O6	Reserved	
	—	O7	Reserved	

## Pin Definition and Functions BGA516 Package Variant Pin Configuration

Table 2-1 Port 00 Functions (cont'd)

Ball	Symbol	Ctrl.	Buffer Type	Function
U2	P00.14	I	SLOW / PU1 / VEXT / ES	General-purpose input
	GTM_TIM6_IN6_2			Mux input channel 6 of TIM module 6
	GTM_TIM5_IN7_1			Mux input channel 7 of TIM module 5
	GTM_TIM4_IN7_1			Mux input channel 7 of TIM module 4
	EDSADC_DSCIN6A			Modulator clock input, channel 6
	P00.14	O0		General-purpose output
	GTM_TOUT166	O1		GTM muxed output
	—	O2		Reserved
	—	O3		Reserved
	EDSADC_DSCOUT6	O4		Modulator clock output
	—	O5		Reserved
	—	O6		Reserved
	—	O7		Reserved
U1	P00.15	I	FAST / PU1 / VEXT / ES	General-purpose input
	GTM_TIM6_IN7_2			Mux input channel 7 of TIM module 6
	GTM_TIM5_IN1_1			Mux input channel 1 of TIM module 5
	GTM_TIM4_IN1_1			Mux input channel 1 of TIM module 4
	EDSADC_ITR6F			Trigger/Gate input, channel 6
	P00.15	O0		General-purpose output
	GTM_TOUT168	O1		GTM muxed output
	—	O2		Reserved
	—	O3		Reserved
	CCU_EXTCLK0	O4		External Clock 0
	—	O5		Reserved
	—	O6		Reserved
	—	O7		Reserved

## Pin Definition and Functions BGA516 Package Variant Pin Configuration

Table 2-2 Port 01 Functions

Ball	Symbol	Ctrl.	Buffer Type	Function	
J2	P01.0	I	SLOW / PU1 / VEXT / ES	General-purpose input	
	GTM_TIM5_IN4_1			Mux input channel 4 of TIM module 5	
	GTM_TIM4_IN4_1			Mux input channel 4 of TIM module 4	
	GTM_TIM2_IN6_13			Mux input channel 6 of TIM module 2	
	CAN21_RXDE			CAN receive input node 1	
	EDSADC_ITR6E			Trigger/Gate input, channel 6	
	CAN03_RXDF			CAN receive input node 3	
	ASCLIN6_ARXB			Receive input	
	P01.0			O0	General-purpose output
	GTM_TOUT155	O1	GTM muxed output		
	—	O2	Reserved		
	—	O3	Reserved		
	—	O4	Reserved		
	—	O5	Reserved		
	—	O6	Reserved		
	—	O7	Reserved		
	K1	P01.1	I	SLOW / PU1 / VEXT / ES	General-purpose input
GTM_TIM5_IN1_2		Mux input channel 1 of TIM module 5			
GTM_TIM4_IN1_2		Mux input channel 1 of TIM module 4			
EDSADC_ITR8E		Trigger/Gate input, channel 8			
ERAY1_RXDA1		Receive Channel A1			
SENT_SENT15B		Receive input channel 15			
P01.1		O0			General-purpose output
GTM_TOUT159		O1			GTM muxed output
—		O2			Reserved
—		O3	Reserved		
ASCLIN6_ATX		O4	Transmit output		
—		O5	Reserved		
—		O6	Reserved		
—		O7	Reserved		

## Pin Definition and Functions BGA516 Package Variant Pin Configuration

Table 2-2 Port 01 Functions (cont'd)

Ball	Symbol	Ctrl.	Buffer Type	Function
K2	P01.2	I	SLOW / PU1 / VEXT / ES	General-purpose input
	GTM_TIM5_IN5_1			Mux input channel 5 of TIM module 5
	GTM_TIM4_IN5_1			Mux input channel 5 of TIM module 4
	EDSADC_DSCIN7A			Modulator clock input, channel 7
	P01.2	O0		General-purpose output
	GTM_TOUT156	O1		GTM muxed output
	—	O2		Reserved
	CAN03_TXD	O3		CAN transmit output node 3
	IOM_MON2_8			Monitor input 2
	IOM_REF2_8			Reference input 2
	—	O4		Reserved
	CAN21_TXD	O5		CAN transmit output node 1
	EDSADC_DSCOUT7	O6		Modulator clock output
	—	O7		Reserved
M10	P01.3	I	SLOW / PU1 / VEXT / ES	General-purpose input
	GTM_TIM4_IN5_2			Mux input channel 5 of TIM module 4
	GTM_TIM2_IN0_14			Mux input channel 0 of TIM module 2
	GTM_TIM0_IN5_8			Mux input channel 5 of TIM module 0
	QSPI3_SLSIB			Slave select input
	EDSADC_ITR7F			Trigger/Gate input, channel 7
	EVADC_G9CH14	AI		Analog input channel 14, group 9
	P01.3	O0		General-purpose output
	GTM_TOUT111	O1		GTM muxed output
	—	O2		Reserved
	—	O3		Reserved
	QSPI3_SLSO9	O4		Master slave select output
	CAN01_TXD	O5		CAN transmit output node 1
	IOM_MON2_6			Monitor input 2
	IOM_REF2_6			Reference input 2
	—	O6		Reserved
	—	O7		Reserved

## Pin Definition and Functions BGA516 Package Variant Pin Configuration

Table 2-2 Port 01 Functions (cont'd)

Ball	Symbol	Ctrl.	Buffer Type	Function
M9	P01.4	I	SLOW / PU1 / VEXT / ES	General-purpose input
	GTM_TIM4_IN6_2			Mux input channel 6 of TIM module 4
	GTM_TIM2_IN1_14			Mux input channel 1 of TIM module 2
	GTM_TIM0_IN6_8			Mux input channel 6 of TIM module 0
	CAN01_RXDC			CAN receive input node 1
	EDSADC_ITR7E			Trigger/Gate input, channel 7
	EVADC_G9CH13			AI
	P01.4	O0	General-purpose output	
	GTM_TOUT112	O1	GTM muxed output	
	—	O2	Reserved	
	ASCLIN9_ASLSO	O3	Slave select signal output	
	QSPI3_SLSO10	O4	Master slave select output	
	—	O5	Reserved	
	—	O6	Reserved	
—	O7	Reserved		
N10	P01.5	I	SLOW / PU1 / VEXT / ES	General-purpose input
	GTM_TIM5_IN3_2			Mux input channel 3 of TIM module 5
	GTM_TIM2_IN3_7			Mux input channel 3 of TIM module 2
	GTM_TIM2_IN2_7			Mux input channel 2 of TIM module 2
	QSPI3_MRSTC			Master SPI data input
	EDSADC_DSCIN8A			Modulator clock input, channel 8
	ASCLIN9_ARXA			Receive input
	EVADC_G9CH12	AI	Analog input channel 12, group 9	
	P01.5	O0	General-purpose output	
	GTM_TOUT113	O1	GTM muxed output	
	—	O2	Reserved	
	—	O3	Reserved	
	QSPI3_MRST	O4	Slave SPI data output	
	IOM_MON2_3		Monitor input 2	
	IOM_REF2_3		Reference input 2	
	—	O5	Reserved	
EDSADC_DSCOUT8	O6	Modulator clock output		
—	O7	Reserved		

## Pin Definition and Functions BGA516 Package Variant Pin Configuration

Table 2-2 Port 01 Functions (cont'd)

Ball	Symbol	Ctrl.	Buffer Type	Function
N9	P01.6	I	FAST / PU1 / VEXT / ES	General-purpose input
	GTM_TIM5_IN6_2			Mux input channel 6 of TIM module 5
	GTM_TIM5_IN5_3			Mux input channel 5 of TIM module 5
	GTM_TIM2_IN5_7			Mux input channel 5 of TIM module 2
	QSPI3_MTSRC			Slave SPI data input
	EDSADC_DSDIN8A			Digital datastream input, channel 8
	P01.6			O0
	GTM_TOUT114	O1	GTM muxed output	
	ASCLIN12_ATX	O2	Transmit output	
	ASCLIN9_ASCLK	O3	Shift clock output	
	QSPI3_MTSR	O4	Master SPI data output	
	—	O5	Reserved	
	—	O6	Reserved	
	—	O7	Reserved	
P10	P01.7	I	FAST / PU1 / VEXT / ES	General-purpose input
	GTM_TIM5_IN7_2			Mux input channel 7 of TIM module 5
	GTM_TIM2_IN7_7			Mux input channel 7 of TIM module 2
	QSPI3_SCLKC			Slave SPI clock inputs
	EDSADC_ITR8F			Trigger/Gate input, channel 8
	ASCLIN9_ARXB			Receive input
	P01.7	O0	General-purpose output	
	GTM_TOUT115	O1	GTM muxed output	
	—	O2	Reserved	
	ASCLIN9_ATX	O3	Transmit output	
	QSPI3_SCLK	O4	Master SPI clock output	
	—	O5	Reserved	
	—	O6	Reserved	
	—	O7	Reserved	

## Pin Definition and Functions BGA516 Package Variant Pin Configuration

Table 2-2 Port 01 Functions (cont'd)

Ball	Symbol	Ctrl.	Buffer Type	Function
L1	P01.8	I	SLOW / PU1 / VEXT / ES	General-purpose input
	GTM_TIM5_IN4_2			Mux input channel 4 of TIM module 5
	GTM_TIM5_IN0_10			Mux input channel 0 of TIM module 5
	GTM_TIM4_IN4_2			Mux input channel 4 of TIM module 4
	CAN00_RXDF			CAN receive input node 0
	ERAY1_RXDB1			Receive Channel B1
	EDSADC_DSDIN9A			Digital datastream input, channel 9
	SENT_SENT17B			Receive input channel 17
	ASCLIN0_ARXC			Receive input
	CAN20_RXDE			CAN receive input node 0
	ASCLIN7_ARXB			Receive input
	P01.8	O0	General-purpose output	
	GTM_TOUT162	O1	GTM muxed output	
	—	O2	Reserved	
	—	O3	Reserved	
	—	O4	Reserved	
	—	O5	Reserved	
—	O6	Reserved		
—	O7	Reserved		
L2	P01.9	I	SLOW / PU1 / VEXT / ES	General-purpose input
	GTM_TIM5_IN2_1			Mux input channel 2 of TIM module 5
	GTM_TIM5_IN1_11			Mux input channel 1 of TIM module 5
	GTM_TIM4_IN2_1			Mux input channel 2 of TIM module 4
	EDSADC_DSCIN9A			Modulator clock input, channel 9
	SENT_SENT16B			Receive input channel 16
	P01.9	O0	General-purpose output	
	GTM_TOUT160	O1	GTM muxed output	
	ASCLIN7_ATX	O2	Transmit output	
	—	O3	Reserved	
	—	O4	Reserved	
	—	O5	Reserved	
	EDSADC_DSCOUT9	O6	Modulator clock output	
	—	O7	Reserved	

## Pin Definition and Functions BGA516 Package Variant Pin Configuration

Table 2-2 Port 01 Functions (cont'd)

Ball	Symbol	Ctrl.	Buffer Type	Function
M2	P01.10	I	SLOW / PU1 / VEXT / ES	General-purpose input
	GTM_TIM5_IN5_2			Mux input channel 5 of TIM module 5
	GTM_TIM5_IN2_9			Mux input channel 2 of TIM module 5
	GTM_TIM4_IN5_3			Mux input channel 5 of TIM module 4
	EDSADC_ITR9F			Trigger/Gate input, channel 9
	SENT_SENT18B			Receive input channel 18
	GTM_DTMT3_2			CDTM3_DTM0
	P01.10			O0
	GTM_TOUT163	O1	GTM muxed output	
	ASCLIN7_ASCLK	O2	Shift clock output	
	—	O3	Reserved	
	—	O4	Reserved	
	—	O5	Reserved	
	—	O6	Reserved	
—	O7	Reserved		
M1	P01.11	I	SLOW / PU1 / VEXT / ES	General-purpose input
	GTM_TIM5_IN7_3			Mux input channel 7 of TIM module 5
	GTM_TIM5_IN3_11			Mux input channel 3 of TIM module 5
	GTM_TIM4_IN7_2			Mux input channel 7 of TIM module 4
	EDSADC_ITR9E			Trigger/Gate input, channel 9
	SENT_SENT19B			Receive input channel 19
	GTM_DTMA5_1			CDTM5_DTM4
	P01.11			O0
	GTM_TOUT165	O1	GTM muxed output	
	ASCLIN7_ASLSO	O2	Slave select signal output	
	—	O3	Reserved	
	—	O4	Reserved	
	—	O5	Reserved	
	—	O6	Reserved	
—	O7	Reserved		

## Pin Definition and Functions BGA516 Package Variant Pin Configuration

Table 2-2 Port 01 Functions (cont'd)

Ball	Symbol	Ctrl.	Buffer Type	Function
N2	P01.12	I	FAST / PU1 / VEXT / ES	General-purpose input
	GTM_TIM6_IN0_3			Mux input channel 0 of TIM module 6
	GTM_TIM5_IN0_2			Mux input channel 0 of TIM module 5
	GTM_TIM4_IN0_2			Mux input channel 0 of TIM module 4
	P01.12	O0		General-purpose output
	GTM_TOUT158	O1		GTM muxed output
	ASCLIN7_ATX	O2		Transmit output
	—	O3		Reserved
	—	O4		Reserved
	—	O5		Reserved
	ERAY1_TXDA	O6		Transmit Channel A
	—	O7		Reserved
N1	P01.13	I	FAST / PU1 / VEXT / ES	General-purpose input
	GTM_TIM6_IN1_3			Mux input channel 1 of TIM module 6
	GTM_TIM5_IN3_1			Mux input channel 3 of TIM module 5
	GTM_TIM4_IN3_1			Mux input channel 3 of TIM module 4
	P01.13	O0		General-purpose output
	GTM_TOUT161	O1		GTM muxed output
	ASCLIN0_ATX	O2		Transmit output
	IOM_MON2_12			Monitor input 2
	IOM_REF2_12			Reference input 2
	—	O3		Reserved
	CAN00_TXD	O4		CAN transmit output node 0
	IOM_MON2_5			Monitor input 2
	IOM_REF2_5			Reference input 2
	CAN20_TXD	O5		CAN transmit output node 0
	ERAY1_TXDB	O6		Transmit Channel B
	—	O7		Reserved

## Pin Definition and Functions BGA516 Package Variant Pin Configuration

Table 2-2 Port 01 Functions (cont'd)

Ball	Symbol	Ctrl.	Buffer Type	Function
P2	P01.14	I	FAST / PU1 / VEXT / ES	General-purpose input
	GTM_TIM6_IN2_3			Mux input channel 2 of TIM module 6
	GTM_TIM5_IN6_3			Mux input channel 6 of TIM module 5
	GTM_TIM4_IN6_3			Mux input channel 6 of TIM module 4
	P01.14	O0		General-purpose output
	GTM_TOUT164	O1		GTM muxed output
	—	O2		Reserved
	—	O3		Reserved
	—	O4		Reserved
	—	O5		Reserved
	ERAY1_TXENA	O6		Transmit Enable Channel A
—	O7	Reserved		
P1	P01.15	I	SLOW / PU1 / VEXT / ES	General-purpose input
	GTM_TIM6_IN3_3			Mux input channel 3 of TIM module 6
	GTM_TIM5_IN6_1			Mux input channel 6 of TIM module 5
	GTM_TIM4_IN6_1			Mux input channel 6 of TIM module 4
	EDSADC_DSDIN7A			Digital datastream input, channel 7
	P01.15	O0		General-purpose output
	GTM_TOUT157	O1		GTM muxed output
	—	O2		Reserved
	—	O3		Reserved
	—	O4		Reserved
	—	O5		Reserved
	—	O6		Reserved
	—	O7		Reserved

## Pin Definition and Functions BGA516 Package Variant Pin Configuration

Table 2-3 Port 02 Functions

Ball	Symbol	Ctrl.	Buffer Type	Function	
G6	P02.0	I	FAST / PU1 / VEXT / ES	<b>General-purpose input</b>	
	GTM_TIM1_IN0_2			<b>Mux input channel 0 of TIM module 1</b>	
	GTM_TIM0_IN0_2			<b>Mux input channel 0 of TIM module 0</b>	
	CCU61_CC60INB			<b>T12 capture input 60</b>	
	ASCLIN2_ARXG			<b>Receive input</b>	
	CCU60_CC60INA			<b>T12 capture input 60</b>	
	SCU_E_REQ3_2			<b>ERU Channel 3 inputs 0 to 5 (0 is the LSB and 5 is the MSB)</b>	
	GTM_DTMA0_0			<b>CDTM0_DTM4</b>	
	P02.0			O0	<b>General-purpose output</b>
	GTM_TOUT0			O1	<b>GTM muxed output</b>
	IOM_REF0_0		<b>Reference input 0</b>		
	ASCLIN2_ATX	O2	<b>Transmit output</b>		
	IOM_MON2_14		<b>Monitor input 2</b>		
	IOM_REF2_14		<b>Reference input 2</b>		
	QSPI3_SLSO1	O3	<b>Master slave select output</b>		
	EDSADC_CGPWMN	O4	<b>Negative carrier generator output</b>		
	CAN00_TXD	O5	<b>CAN transmit output node 0</b>		
	IOM_MON2_5		<b>Monitor input 2</b>		
	IOM_REF2_5		<b>Reference input 2</b>		
	ERAY0_TXDA	O6	<b>Transmit Channel A</b>		
CCU60_CC60	O7	<b>T12 PWM channel 60</b>			
IOM_MON1_2		<b>Monitor input 1</b>			
IOM_REF1_6		<b>Reference input 1</b>			

## Pin Definition and Functions BGA516 Package Variant Pin Configuration

Table 2-3 Port 02 Functions (cont'd)

Ball	Symbol	Ctrl.	Buffer Type	Function
H7	P02.1	I	SLOW / PU1 / VEXT / ES	General-purpose input
	GTM_TIM1_IN1_2			Mux input channel 1 of TIM module 1
	GTM_TIM0_IN1_2			Mux input channel 1 of TIM module 0
	ERAY0_RXDA2			Receive Channel A2
	ASCLIN2_ARXB			Receive input
	CAN00_RXDA			CAN receive input node 0
	SCU_E_REQ2_1			ERU Channel 2 inputs 0 to 5 (0 is the LSB and 5 is the MSB)
	P02.1	O0	General-purpose output	
	GTM_TOUT1	O1	GTM muxed output	
	IOM_REF0_1		Reference input 0	
	QSPI4_SLSO7	O2	Master slave select output	
	QSPI3_SLSO2	O3	Master slave select output	
	EDSADC_CGPWMP	O4	Positive carrier generator output	
	—	O5	Reserved	
	—	O6	Reserved	
	CCU60_COUT60	O7	T12 PWM channel 60	
	IOM_MON1_3		Monitor input 1	
	IOM_REF1_3		Reference input 1	

## Pin Definition and Functions BGA516 Package Variant Pin Configuration

Table 2-3 Port 02 Functions (cont'd)

Ball	Symbol	Ctrl.	Buffer Type	Function
H6	P02.2	I	FAST / PU1 / VEXT / ES	General-purpose input
	GTM_TIM1_IN2_2			Mux input channel 2 of TIM module 1
	GTM_TIM0_IN2_2			Mux input channel 2 of TIM module 0
	CCU61_CC61INB			T12 capture input 61
	CCU60_CC61INA			T12 capture input 61
	SENT_SENT14B			Receive input channel 14
	P02.2			O0
	GTM_TOUT2	O1	GTM muxed output	
	IOM_REF0_2		Reference input 0	
	ASCLIN1_ATX	O2	Transmit output	
	IOM_MON2_13		Monitor input 2	
	IOM_REF2_13		Reference input 2	
	QSPI3_SLSO3	O3	Master slave select output	
	PSI5_TX0	O4	TXD outputs (send data)	
	IOM_MON1_14		Monitor input 1	
	IOM_REF1_14		Reference input 1	
	CAN02_TXD	O5	CAN transmit output node 2	
	IOM_MON2_7		Monitor input 2	
	IOM_REF2_7		Reference input 2	
	ERAY0_TXDB	O6	Transmit Channel B	
	CCU60_CC61	O7	T12 PWM channel 61	
	IOM_MON1_1		Monitor input 1	
	IOM_REF1_5		Reference input 1	

## Pin Definition and Functions BGA516 Package Variant Pin Configuration

Table 2-3 Port 02 Functions (cont'd)

Ball	Symbol	Ctrl.	Buffer Type	Function
J7	P02.3	I	SLOW / PU1 / VEXT / ES	General-purpose input
	GTM_TIM1_IN3_2			Mux input channel 3 of TIM module 1
	GTM_TIM0_IN3_2			Mux input channel 3 of TIM module 0
	EDSADC_DSCIN5B			Modulator clock input, channel 5
	ERAY0_RXDB2			Receive Channel B2
	CAN02_RXDB			CAN receive input node 2
	ASCLIN1_ARXG			Receive input
	MSC1_SD11			Upstream asynchronous input signal
	PSI5_RX0B			RXD inputs (receive data) channel 0
	SENT_SENT13B			Receive input channel 13
	P02.3	O0	General-purpose output	
	GTM_TOUT3	O1	GTM muxed output	
	IOM_REF0_3		Reference input 0	
	ASCLIN2_ASLSO	O2	Slave select signal output	
	QSPI3_SLSO4	O3	Master slave select output	
	EDSADC_DSCOUT5	O4	Modulator clock output	
	—	O5	Reserved	
	—	O6	Reserved	
	CCU60_COUT61	O7	T12 PWM channel 61	
	IOM_MON1_4		Monitor input 1	
IOM_REF1_2		Reference input 1		

## Pin Definition and Functions BGA516 Package Variant Pin Configuration

Table 2-3 Port 02 Functions (cont'd)

Ball	Symbol	Ctrl.	Buffer Type	Function
J6	P02.4	I	FAST / PU1 / VEXT / ES	General-purpose input
	GTM_TIM1_IN4_1			Mux input channel 4 of TIM module 1
	GTM_TIM0_IN4_1			Mux input channel 4 of TIM module 0
	CCU61_CC62INB			T12 capture input 62
	EDSADC_DSDIN5B			Digital datastream input, channel 5
	QSPI3_SLSIA			Slave select input
	CCU60_CC62INA			T12 capture input 62
	I2C0_SDAA			Serial Data Input 0
	CAN11_RXDA			CAN receive input node 1
	CAN0_ECTT1			External CAN time trigger input
	SENT_SENT12B			Receive input channel 12
	P02.4			O0
	GTM_TOUT4	O1	GTM muxed output	
	IOM_REF0_4		Reference input 0	
	ASCLIN2_ASCLK	O2	Shift clock output	
	QSPI3_SLSO0	O3	Master slave select output	
	PSI5S_CLK	O4	PSI5S CLK is a clock that can be used on a pin to drive the external PHY.	
	I2C0_SDA	O5	Serial Data Output	
	ERAY0_TXENA	O6	Transmit Enable Channel A	
	CCU60_CC62	O7	T12 PWM channel 62	
IOM_MON1_0		Monitor input 1		
IOM_REF1_4		Reference input 1		

## Pin Definition and Functions BGA516 Package Variant Pin Configuration

Table 2-3 Port 02 Functions (cont'd)

Ball	Symbol	Ctrl.	Buffer Type	Function	
K7	P02.5	I	FAST / PU1 / VEXT / ES	General-purpose input	
	GTM_TIM1_IN5_1			Mux input channel 5 of TIM module 1	
	GTM_TIM0_IN5_1			Mux input channel 5 of TIM module 0	
	EDSADC_DSCIN4B			Modulator clock input, channel 4	
	I2C0_SCLA			Serial Clock Input 0	
	PSI5_RX1B			RXD inputs (receive data) channel 1	
	PSI5S_RXB			RX data input	
	QSPI3_MRSTA			Master SPI data input	
	SENT_SENT3C			Receive input channel 3	
	CAN0_ECTT2			External CAN time trigger input	
	P02.5			O0	General-purpose output
	GTM_TOUT5			O1	GTM muxed output
	IOM_REF0_5		Reference input 0		
	CAN11_TXD	O2	CAN transmit output node 1		
	QSPI3_MRST	O3	Slave SPI data output		
	IOM_MON2_3		Monitor input 2		
	IOM_REF2_3		Reference input 2		
	EDSADC_DSCOUT4	O4	Modulator clock output		
	I2C0_SCL	O5	Serial Clock Output		
	ERAY0_TXENB	O6	Transmit Enable Channel B		
CCU60_COUT62	O7	T12 PWM channel 62			
IOM_MON1_5		Monitor input 1			
IOM_REF1_1		Reference input 1			

## Pin Definition and Functions BGA516 Package Variant Pin Configuration

Table 2-3 Port 02 Functions (cont'd)

Ball	Symbol	Ctrl.	Buffer Type	Function
K6	P02.6	I	FAST / PU1 / VEXT / ES	General-purpose input
	GTM_TIM3_IN0_10			Mux input channel 0 of TIM module 3
	GTM_TIM1_IN6_1			Mux input channel 6 of TIM module 1
	GTM_TIM0_IN6_1			Mux input channel 6 of TIM module 0
	CCU60_CC60INC			T12 capture input 60
	SENT_SENT2C			Receive input channel 2
	EDSADC_DSDIN4B			Digital datastream input, channel 4
	EDSADC_ITR5E			Trigger/Gate input, channel 5
	GPT120_T3INA			Trigger/gate input of core timer T3
	CCU60_CCPOS0A			Hall capture input 0
	CCU61_T12HRB			External timer start 12
	QSPI3_MTSRA			Slave SPI data input
	P02.6			O0
	GTM_TOUT6	O1	GTM muxed output	
	IOM_REF0_6		Reference input 0	
	PSI5S_TX	O2	TX data output	
	QSPI3_MTSR	O3	Master SPI data output	
	PSI5_TX1	O4	TXD outputs (send data)	
	IOM_MON1_15		Monitor input 1	
	EVADC_EMUX00	O5	Control of external analog multiplexer interface 0	
—	O6	Reserved		
CCU60_CC60	O7	T12 PWM channel 60		
IOM_MON1_2		Monitor input 1		
IOM_REF1_6		Reference input 1		

## Pin Definition and Functions BGA516 Package Variant Pin Configuration

Table 2-3 Port 02 Functions (cont'd)

Ball	Symbol	Ctrl.	Buffer Type	Function
L7	P02.7	I	FAST / PU1 / VEXT / ES	General-purpose input
	GTM_TIM3_IN1_10			Mux input channel 1 of TIM module 3
	GTM_TIM1_IN7_1			Mux input channel 7 of TIM module 1
	GTM_TIM0_IN7_1			Mux input channel 7 of TIM module 0
	CCU60_CC61INC			T12 capture input 61
	SENT_SENT1C			Receive input channel 1
	EDSADC_DSCIN3B			Modulator clock input, channel 3
	EDSADC_ITR4E			Trigger/Gate input, channel 4
	GPT120_T3EUDA			Count direction control input of core timer T3
	PSI5_RX2B			RXD inputs (receive data) channel 2
	CCU60_CCPOS1A			Hall capture input 1
	QSPI3_SCLKA			Slave SPI clock inputs
	CCU61_T13HRB			External timer start 13
	P02.7			O0
	GTM_TOUT7	O1	GTM muxed output	
	IOM_REF0_7		Reference input 0	
	—	O2	Reserved	
	QSPI3_SCLK	O3	Master SPI clock output	
	EDSADC_DSCOUT3	O4	Modulator clock output	
	EVADC_EMUX01	O5	Control of external analog multiplexer interface 0	
	SENT_SPC1	O6	Transmit output	
	CCU60_CC61	O7	T12 PWM channel 61	
	IOM_MON1_1		Monitor input 1	
IOM_REF1_5	Reference input 1			

## Pin Definition and Functions BGA516 Package Variant Pin Configuration

Table 2-3 Port 02 Functions (cont'd)

Ball	Symbol	Ctrl.	Buffer Type	Function
L6	P02.8	I	SLOW / PU1 / VEXT / ES	General-purpose input
	GTM_TIM3_IN2_10			Mux input channel 2 of TIM module 3
	GTM_TIM3_IN0_2			Mux input channel 0 of TIM module 3
	GTM_TIM2_IN0_2			Mux input channel 0 of TIM module 2
	CCU60_CC62INC			T12 capture input 62
	SENT_SENT0C			Receive input channel 0
	CCU60_CCPOS2A			Hall capture input 2
	EDSADC_DSDIN3B			Digital datastream input, channel 3
	EDSADC_ITR3E			Trigger/Gate input, channel 3
	GPT120_T4INA			Trigger/gate input of timer T4
	CCU61_T12HRC			External timer start 12
	CCU61_T13HRC			External timer start 13
	GTM_DTMA0_1			CDTM0_DTM4
	P02.8			O0
	GTM_TOUT8	O1	GTM muxed output	
	IOM_REF0_8		Reference input 0	
	QSPI3_SLSO5	O2	Master slave select output	
	ASCLIN8_ASCLK	O3	Shift clock output	
	PSI5_TX2	O4	TXD outputs (send data)	
	IOM_REF1_15		Reference input 1	
EVADC_EMUX02	O5	Control of external analog multiplexer interface 0		
GETH_MDC	O6	MDIO clock		
CCU60_CC62	O7	T12 PWM channel 62		
IOM_MON1_0		Monitor input 1		
IOM_REF1_4		Reference input 1		

## Pin Definition and Functions BGA516 Package Variant Pin Configuration

Table 2-3 Port 02 Functions (cont'd)

Ball	Symbol	Ctrl.	Buffer Type	Function
K9	P02.9	I	SLOW / PU1 / VEXT / ES	General-purpose input
	GTM_TIM4_IN2_2			Mux input channel 2 of TIM module 4
	GTM_TIM3_IN3_10			Mux input channel 3 of TIM module 3
	GTM_TIM0_IN2_10			Mux input channel 2 of TIM module 0
	SENT_SENT20B			Receive input channel 20
	ASCLIN8_ARXA			Receive input
	P02.9	O0	General-purpose output	
	GTM_TOUT116	O1	GTM muxed output	
	ASCLIN2_ATX	O2	Transmit output	
	IOM_MON2_14		Monitor input 2	
	IOM_REF2_14	O3	Reference input 2	
	ASCLIN8_ATX		Transmit output	
	—	O4	Reserved	
	CAN01_TXD	O5	CAN transmit output node 1	
	IOM_MON2_6		Monitor input 2	
	IOM_REF2_6	O6	Reference input 2	
	—		Reserved	
	—	O7	Reserved	
L10	P02.10	I	SLOW / PU1 / VEXT / ES	General-purpose input
	GTM_TIM4_IN3_2			Mux input channel 3 of TIM module 4
	GTM_TIM3_IN4_11			Mux input channel 4 of TIM module 3
	GTM_TIM0_IN3_10			Mux input channel 3 of TIM module 0
	ASCLIN2_ARXC			Receive input
	CAN01_RXDE			CAN receive input node 1
	SENT_SENT21B	Receive input channel 21		
	ASCLIN8_ARXB	Receive input		
	P02.10	O0	General-purpose output	
	GTM_TOUT117	O1	GTM muxed output	
	—	O2	Reserved	
	—	O3	Reserved	
	—	O4	Reserved	
	—	O5	Reserved	
	—	O6	Reserved	
	—	O7	Reserved	

## Pin Definition and Functions BGA516 Package Variant Pin Configuration

Table 2-3 Port 02 Functions (cont'd)

Ball	Symbol	Ctrl.	Buffer Type	Function
L9	P02.11	I	SLOW / PU1 / VEXT / ES	General-purpose input
	GTM_TIM4_IN4_3			Mux input channel 4 of TIM module 4
	GTM_TIM3_IN5_12			Mux input channel 5 of TIM module 3
	GTM_TIM0_IN7_7			Mux input channel 7 of TIM module 0
	SENT_SENT22B			Receive input channel 22
	EVADC_G9CH15	AI		Analog input channel 15, group 9
	P02.11	O0		General-purpose output
	GTM_TOUT118	O1		GTM muxed output
	—	O2		Reserved
	ASCLIN8_ASLSO	O3		Slave select signal output
	—	O4		Reserved
	—	O5		Reserved
	—	O6		Reserved
—	O7	Reserved		
F2	P02.12	I	SLOW / PU1 / VEXT / ES	General-purpose input
	GTM_TIM5_IN0_3			Mux input channel 0 of TIM module 5
	GTM_TIM4_IN0_3			Mux input channel 0 of TIM module 4
	GTM_TIM3_IN6_12			Mux input channel 6 of TIM module 3
	SENT_SENT23B			Receive input channel 23
	P02.12	O0		General-purpose output
	GTM_TOUT151	O1		GTM muxed output
	QSPI3_SLSO5	O2		Master slave select output
	QSPI4_SLSO4	O3		Master slave select output
	ASCLIN6_ASLSO	O4		Slave select signal output
	—	O5		Reserved
	—	O6		Reserved
	—	O7		Reserved

## Pin Definition and Functions BGA516 Package Variant Pin Configuration

Table 2-3 Port 02 Functions (cont'd)

Ball	Symbol	Ctrl.	Buffer Type	Function
F1	P02.13	I	SLOW / PU1 / VEXT / ES	General-purpose input
	GTM_TIM5_IN2_2			Mux input channel 2 of TIM module 5
	GTM_TIM4_IN2_3			Mux input channel 2 of TIM module 4
	GTM_TIM3_IN7_11			Mux input channel 7 of TIM module 3
	SENT_SENT24B			Receive input channel 24
	P02.13	O0		General-purpose output
	GTM_TOUT153	O1		GTM muxed output
	QSPI3_SLSO7	O2		Master slave select output
	QSPI4_SLSO6	O3		Master slave select output
	CAN00_TXD	O4		CAN transmit output node 0
	IOM_MON2_5			Monitor input 2
	IOM_REF2_5			Reference input 2
	CAN20_TXD	O5		CAN transmit output node 0
	—	O6		Reserved
—	O7	Reserved		
G2	P02.14	I	SLOW / PU1 / VEXT / ES	General-purpose input
	GTM_TIM5_IN3_3			Mux input channel 3 of TIM module 5
	GTM_TIM4_IN3_3			Mux input channel 3 of TIM module 4
	GTM_TIM2_IN4_14			Mux input channel 4 of TIM module 2
	CAN20_RXDD			CAN receive input node 0
	CAN00_RXDH	CAN receive input node 0		
	P02.14	O0		General-purpose output
	GTM_TOUT154	O1		GTM muxed output
	ASCLIN6_ASCLK	O2		Shift clock output
	—	O3		Reserved
	—	O4		Reserved
	—	O5		Reserved
	—	O6		Reserved
	—	O7		Reserved

## Pin Definition and Functions BGA516 Package Variant Pin Configuration

Table 2-3 Port 02 Functions (cont'd)

Ball	Symbol	Ctrl.	Buffer Type	Function
G1	P02.15	I	FAST / PU1 / VEXT / ES	General-purpose input
	GTM_TIM5_IN1_3			Mux input channel 1 of TIM module 5
	GTM_TIM4_IN1_3			Mux input channel 1 of TIM module 4
	GTM_TIM2_IN5_14			Mux input channel 5 of TIM module 2
	P02.15	O0	General-purpose output	
	GTM_TOUT152	O1	GTM muxed output	
	QSPI3_SLSO6	O2	Master slave select output	
	QSPI4_SLSO5	O3	Master slave select output	
	ASCLIN6_ATX	O4	Transmit output	
	—	O5	Reserved	
	ERAY1_TXENB	O6	Transmit Enable Channel B	
	—	O7	Reserved	

Table 2-4 Port 10 Functions

Ball	Symbol	Ctrl.	Buffer Type	Function
F12	P10.0	I	SLOW / PU1 / VEXT / ES	General-purpose input
	GTM_TIM4_IN0_12			Mux input channel 0 of TIM module 4
	GTM_TIM1_IN4_2			Mux input channel 4 of TIM module 1
	GTM_TIM0_IN4_2			Mux input channel 4 of TIM module 0
	GPT120_T6EUDB			Count direction control input of core timer T6
	ASCLIN11_ARXA			Receive input
	GETH_RXERC			Receive Error MII
	GTM_DTMA5_2			CDTM5_DTM4
	P10.0			O0
	GTM_TOUT102	O1	GTM muxed output	
	ASCLIN11_ATX	O2	Transmit output	
	QSPI1_SLSO10	O3	Master slave select output	
	—	O4	Reserved	
	—	O5	Reserved	
	ASCLIN22_ATX	O6	Transmit output	
	—	O7	Reserved	

## Pin Definition and Functions BGA516 Package Variant Pin Configuration

Table 2-4 Port 10 Functions (cont'd)

Ball	Symbol	Ctrl.	Buffer Type	Function	
G12	P10.1	I	FAST / PU1 / VEXT / ES	General-purpose input	
	GTM_TIM4_IN4_12			Mux input channel 4 of TIM module 4	
	GTM_TIM1_IN1_3			Mux input channel 1 of TIM module 1	
	GTM_TIM0_IN1_3			Mux input channel 1 of TIM module 0	
	GPT120_T5EUDB			Count direction control input of timer T5	
	QSPI1_MRSTA			Master SPI data input	
	GTM_DTMT0_1			CDTM0_DTM0	
	P10.1			O0	General-purpose output
	GTM_TOUT103			O1	GTM muxed output
	QSPI1_MTSR			O2	Master SPI data output
	QSPI1_MRST			O3	Slave SPI data output
	IOM_MON2_1				Monitor input 2
	IOM_REF2_1				Reference input 2
	MSC0_EN1			O4	Chip Select
	EVADC_FC1BFLOUT			O5	Boundary flag output, FC channel 1
	—			O6	Reserved
	—			O7	Reserved
F10	P10.2	I	FAST / PU1 / VEXT / ES	General-purpose input	
	GTM_TIM4_IN5_12			Mux input channel 5 of TIM module 4	
	GTM_TIM1_IN2_3			Mux input channel 2 of TIM module 1	
	GTM_TIM0_IN2_3			Mux input channel 2 of TIM module 0	
	CAN02_RXDE			CAN receive input node 2	
	MSC0_SD11			Upstream asynchronous input signal	
	QSPI1_SCLKA			Slave SPI clock inputs	
	GPT120_T6INB			Trigger/gate input of core timer T6	
	SCU_E_REQ2_0			ERU Channel 2 inputs 0 to 5 (0 is the LSB and 5 is the MSB)	
	GTM_DTMT2_2			CDTM2_DTM0	
	P10.2			O0	General-purpose output
	GTM_TOUT104			O1	GTM muxed output
	IOM_MON2_9				Monitor input 2
	—			O2	Reserved
	QSPI1_SCLK			O3	Master SPI clock output
	MSC0_EN0			O4	Chip Select
	EVADC_FC3BFLOUT			O5	Boundary flag output, FC channel 3
—	O6	Reserved			
—	O7	Reserved			

## Pin Definition and Functions BGA516 Package Variant Pin Configuration

Table 2-4 Port 10 Functions (cont'd)

Ball	Symbol	Ctrl.	Buffer Type	Function
F11	P10.3	I	FAST / PU1 / VEXT / ES	General-purpose input
	GTM_TIM4_IN6_10			Mux input channel 6 of TIM module 4
	GTM_TIM1_IN3_3			Mux input channel 3 of TIM module 1
	GTM_TIM0_IN3_3			Mux input channel 3 of TIM module 0
	QSPI1_MTSRA			Slave SPI data input
	SCU_E_REQ3_0			ERU Channel 3 inputs 0 to 5 (0 is the LSB and 5 is the MSB)
	GPT120_T5INB			Trigger/gate input of timer T5
	P10.3	O0	General-purpose output	
	GTM_TOUT105	O1	GTM muxed output	
	IOM_MON2_10		Monitor input 2	
	—	O2	Reserved	
	QSPI1_MTSR	O3	Master SPI data output	
	MSC0_EN0	O4	Chip Select	
	—	O5	Reserved	
	CAN02_TXD	O6	CAN transmit output node 2	
	IOM_MON2_7		Monitor input 2	
	IOM_REF2_7		Reference input 2	
—	O7	Reserved		
G11	P10.4	I	FAST / PU1 / VEXT / ES	General-purpose input
	GTM_TIM4_IN7_3			Mux input channel 7 of TIM module 4
	GTM_TIM1_IN6_2			Mux input channel 6 of TIM module 1
	GTM_TIM0_IN6_2			Mux input channel 6 of TIM module 0
	QSPI1_MTSRC			Slave SPI data input
	CCU60_CCPOS0C			Hall capture input 0
	GPT120_T3INB			Trigger/gate input of core timer T3
	ASCLIN11_ARXB	Receive input		
	ASCLIN22_ARXA	Receive input		
	P10.4	O0	General-purpose output	
	GTM_TOUT106	O1	GTM muxed output	
	IOM_MON2_11		Monitor input 2	
	ASCLIN22_ATX	O2	Transmit output	
	QSPI1_SLSO8	O3	Master slave select output	
	QSPI1_MTSR	O4	Master SPI data output	
	MSC0_EN0	O5	Chip Select	
	—	O6	Reserved	
—	O7	Reserved		

## Pin Definition and Functions BGA516 Package Variant Pin Configuration

Table 2-4 Port 10 Functions (cont'd)

Ball	Symbol	Ctrl.	Buffer Type	Function
G10	P10.5	I	SLOW / PU2 / VEXT / ES	General-purpose input
	GTM_TIM4_IN3_13			Mux input channel 3 of TIM module 4
	GTM_TIM1_IN2_4			Mux input channel 2 of TIM module 1
	GTM_TIM0_IN2_4			Mux input channel 2 of TIM module 0
	PMS_HWCFG4IN			HWCFG4 pin input
	CAN20_RXDA			CAN receive input node 0
	MSC0_INJ1			Injection signal from port
	ASCLIN22_ARXB			Receive input
	P10.5			O0
	GTM_TOUT107	O1	GTM muxed output	
	IOM_REF2_9	O2	Reference input 2	
	ASCLIN2_ATX		Transmit output	
	IOM_MON2_14		Monitor input 2	
	IOM_REF2_14	Reference input 2		
	QSPI3_SLSO8	O3	Master slave select output	
	QSPI1_SLSO9	O4	Master slave select output	
	GPT120_T6OUT	O5	External output for overflow/underflow detection of core timer T6	
	ASCLIN2_ASLSO	O6	Slave select signal output	
	PSI5_TX3	O7	TXD outputs (send data)	

## Pin Definition and Functions BGA516 Package Variant Pin Configuration

Table 2-4 Port 10 Functions (cont'd)

Ball	Symbol	Ctrl.	Buffer Type	Function
F9	P10.6	I	SLOW / PU2 / VEXT / ES	General-purpose input
	GTM_TIM4_IN2_13			Mux input channel 2 of TIM module 4
	GTM_TIM1_IN3_4			Mux input channel 3 of TIM module 1
	GTM_TIM0_IN3_4			Mux input channel 3 of TIM module 0
	PSI5_RX3C			RXD inputs (receive data) channel 3
	ASCLIN2_ARXD			Receive input
	QSPI3_MTSRB			Slave SPI data input
	PMS_HWCFG5IN			HWCFG5 pin input
	ASCLIN23_ARXA			Receive input
	P10.6			O0
	GTM_TOUT108	O1	GTM muxed output	
	IOM_REF2_10		Reference input 2	
	ASCLIN2_ASCLK	O2	Shift clock output	
	QSPI3_MTSR	O3	Master SPI data output	
	GPT120_T3OUT	O4	External output for overflow/underflow detection of core timer T3	
	CAN20_TXD	O5	CAN transmit output node 0	
	QSPI1_MRST	O6	Slave SPI data output	
	IOM_MON2_1		Monitor input 2	
	IOM_REF2_1		Reference input 2	
	—	O7	Reserved	

## Pin Definition and Functions BGA516 Package Variant Pin Configuration

Table 2-4 Port 10 Functions (cont'd)

Ball	Symbol	Ctrl.	Buffer Type	Function
F8	P10.7	I	SLOW / PU1 / VEXT / ES	General-purpose input
	GTM_TIM1_IN0_3			Mux input channel 0 of TIM module 1
	GTM_TIM0_IN0_3			Mux input channel 0 of TIM module 0
	GPT120_T3EUDB			Count direction control input of core timer T3
	ASCLIN2_ACTSA			Clear to send input
	QSPI3_MRSTB			Master SPI data input
	SCU_E_REQ0_2			ERU Channel 0 inputs 0 to 5 (0 is the LSB and 5 is the MSB)
	CCU60_CCPOS1C			Hall capture input 1
	ASCLIN23_ARXB			Receive input
	P10.7			O0
	GTM_TOUT109	O1	GTM muxed output	
	IOM_REF2_11		Reference input 2	
	ASCLIN23_ATX	O2	Transmit output	
	QSPI3_MRST	O3	Slave SPI data output	
	IOM_MON2_3		Monitor input 2	
	IOM_REF2_3		Reference input 2	
	—	O4	Reserved	
	CAN20_TXD	O5	CAN transmit output node 0	
	CAN12_TXD	O6	CAN transmit output node 2	
—	O7	Reserved		

## Pin Definition and Functions BGA516 Package Variant Pin Configuration

Table 2-4 Port 10 Functions (cont'd)

Ball	Symbol	Ctrl.	Buffer Type	Function
G9	P10.8	I	SLOW / PU1 / VEXT / ES	General-purpose input
	GTM_TIM4_IN0_13			Mux input channel 0 of TIM module 4
	GTM_TIM1_IN5_2			Mux input channel 5 of TIM module 1
	GTM_TIM0_IN5_2			Mux input channel 5 of TIM module 0
	CAN12_RXDB			CAN receive input node 2
	GPT120_T4INB			Trigger/gate input of timer T4
	QSPI3_SCLKB			Slave SPI clock inputs
	SCU_E_REQ1_2			ERU Channel 1 inputs 0 to 5 (0 is the LSB and 5 is the MSB)
	CCU60_CCPOS2C			Hall capture input 2
	CAN20_RXDB			CAN receive input node 0
	P10.8	O0	General-purpose output	
	GTM_TOUT110	O1	GTM muxed output	
	ASCLIN2_ARTS	O2	Ready to send output	
	QSPI3_SCLK	O3	Master SPI clock output	
	ASCLIN23_ATX	O4	Transmit output	
	—	O5	Reserved	
	—	O6	Reserved	
—	O7	Reserved		
B8	P10.9	I	SLOW / PU1 / VEXT / ES	General-purpose input
	GTM_TIM6_IN0_5			Mux input channel 0 of TIM module 6
	GTM_TIM4_IN1_4			Mux input channel 1 of TIM module 4
	GTM_TIM0_IN1_10			Mux input channel 1 of TIM module 0
	SENT_SENT15C			Receive input channel 15
	ASCLIN6_ARXD			Receive input
	P10.9	O0	General-purpose output	
	GTM_TOUT265	O1	GTM muxed output	
	—	O2	Reserved	
	—	O3	Reserved	
	—	O4	Reserved	
	—	O5	Reserved	
	—	O6	Reserved	
	—	O7	Reserved	

## Pin Definition and Functions BGA516 Package Variant Pin Configuration

Table 2-4 Port 10 Functions (cont'd)

Ball	Symbol	Ctrl.	Buffer Type	Function
B7	P10.10	I	SLOW / PU1 / VEXT / ES	General-purpose input
	GTM_TIM6_IN1_5			Mux input channel 1 of TIM module 6
	GTM_TIM4_IN2_4			Mux input channel 2 of TIM module 4
	GTM_TIM0_IN2_11			Mux input channel 2 of TIM module 0
	SENT_SENT16C			Receive input channel 16
	P10.10	O0		General-purpose output
	GTM_TOUT266	O1		GTM muxed output
	ASCLIN6_ATX	O2		Transmit output
	—	O3		Reserved
	—	O4		Reserved
	—	O5		Reserved
	—	O6		Reserved
	—	O7		Reserved
A7	P10.11	I	SLOW / PU1 / VEXT / ES	General-purpose input
	GTM_TIM6_IN2_5			Mux input channel 2 of TIM module 6
	GTM_TIM4_IN5_4			Mux input channel 5 of TIM module 4
	GTM_TIM0_IN5_9			Mux input channel 5 of TIM module 0
	SENT_SENT19C			Receive input channel 19
	P10.11	O0		General-purpose output
	GTM_TOUT269	O1		GTM muxed output
	ASCLIN6_ASCLK	O2		Shift clock output
	—	O3		Reserved
	—	O4		Reserved
	—	O5		Reserved
	—	O6		Reserved
	—	O7		Reserved

## Pin Definition and Functions BGA516 Package Variant Pin Configuration

Table 2-4 Port 10 Functions (cont'd)

Ball	Symbol	Ctrl.	Buffer Type	Function
A6	P10.13	I	SLOW / PU1 / VEXT / ES	General-purpose input
	GTM_TIM6_IN3_5			Mux input channel 3 of TIM module 6
	GTM_TIM4_IN4_4			Mux input channel 4 of TIM module 4
	GTM_TIM0_IN4_9			Mux input channel 4 of TIM module 0
	SENT_SENT18C			Receive input channel 18
	P10.13	O0	General-purpose output	
	GTM_TOUT268	O1	GTM muxed output	
	ASCLIN6_ASLSO	O2	Slave select signal output	
	—	O3	Reserved	
	—	O4	Reserved	
	—	O5	Reserved	
	—	O6	Reserved	
—	O7	Reserved		
B5	P10.14	I	SLOW / PU1 / VEXT / ES	General-purpose input
	GTM_TIM4_IN3_4			Mux input channel 3 of TIM module 4
	GTM_TIM0_IN3_11			Mux input channel 3 of TIM module 0
	SENT_SENT17C			Receive input channel 17
	P10.14	O0	General-purpose output	
	GTM_TOUT267	O1	GTM muxed output	
	—	O2	Reserved	
	—	O3	Reserved	
	—	O4	Reserved	
	—	O5	Reserved	
	—	O6	Reserved	
	—	O7	Reserved	
A5	P10.15	I	SLOW / PU1 / VEXT / ES	General-purpose input
	GTM_TIM4_IN6_4			Mux input channel 6 of TIM module 4
	GTM_TIM0_IN6_9			Mux input channel 6 of TIM module 0
	P10.15	O0	General-purpose output	
	GTM_TOUT270	O1	GTM muxed output	
	—	O2	Reserved	
	—	O3	Reserved	
	—	O4	Reserved	
	—	O5	Reserved	
	—	O6	Reserved	
	—	O7	Reserved	

## Pin Definition and Functions BGA516 Package Variant Pin Configuration

Table 2-5 Port 11 Functions

Ball	Symbol	Ctrl.	Buffer Type	Function	
K15	P11.0	I	RFAST / PU1 / VFLEX / ES	<b>General-purpose input</b>	
	GTM_TIM4_IN0_4			<b>Mux input channel 0 of TIM module 4</b>	
	GTM_TIM2_IN0_7			<b>Mux input channel 0 of TIM module 2</b>	
	ASCLIN3_ARXB			<b>Receive input</b>	
	GTM_DTMA2_1			<b>CDTM2_DTM4</b>	
	P11.0			O0	<b>General-purpose output</b>
	GTM_TOUT119			O1	<b>GTM muxed output</b>
	ASCLIN3_ATX			O2	<b>Transmit output</b>
	IOM_MON2_15				<b>Monitor input 2</b>
	IOM_REF2_15				<b>Reference input 2</b>
	—			O3	<b>Reserved</b>
	—			O4	<b>Reserved</b>
	CAN11_TXD			O5	<b>CAN transmit output node 1</b>
	GETH_TXD3			O6	<b>Transmit Data</b>
—	O7	<b>Reserved</b>			
K14	P11.1	I	RFAST / PU1 / VFLEX / ES	<b>General-purpose input</b>	
	GTM_TIM4_IN1_5			<b>Mux input channel 1 of TIM module 4</b>	
	GTM_TIM2_IN1_6			<b>Mux input channel 1 of TIM module 2</b>	
	P11.1			O0	<b>General-purpose output</b>
	GTM_TOUT120			O1	<b>GTM muxed output</b>
	ASCLIN3_ASCLK			O2	<b>Shift clock output</b>
	ASCLIN3_ATX			O3	<b>Transmit output</b>
	IOM_MON2_15				<b>Monitor input 2</b>
	IOM_REF2_15				<b>Reference input 2</b>
	—			O4	<b>Reserved</b>
	CAN12_TXD			O5	<b>CAN transmit output node 2</b>
	GETH_TXD2			O6	<b>Transmit Data</b>
	—			O7	<b>Reserved</b>

## Pin Definition and Functions BGA516 Package Variant Pin Configuration

Table 2-5 Port 11 Functions (cont'd)

Ball	Symbol	Ctrl.	Buffer Type	Function
F15	P11.2	I	RFAST / PU1 / VFLEX / ES	General-purpose input
	GTM_TIM3_IN1_3			Mux input channel 1 of TIM module 3
	GTM_TIM2_IN1_3			Mux input channel 1 of TIM module 2
	P11.2	O0		General-purpose output
	GTM_TOUT95	O1		GTM muxed output
	—	O2		Reserved
	QSPIO_SLSO5	O3		Master slave select output
	QSPI1_SLSO5	O4		Master slave select output
	MSC0_EN1	O5		Chip Select
	GETH_TXD1	O6		Transmit Data
	CCU60_COUT63	O7		T13 PWM channel 63
	IOM_MON1_6			Monitor input 1
	IOM_REF1_0			Reference input 1
	G15	P11.3		I
GTM_TIM3_IN2_2		Mux input channel 2 of TIM module 3		
GTM_TIM2_IN2_2		Mux input channel 2 of TIM module 2		
MSC0_SDI3		Upstream assynchronous input signal		
QSPI1_MRSTB			Master SPI data input	
P11.3		O0	General-purpose output	
GTM_TOUT96		O1	GTM muxed output	
—		O2	Reserved	
QSPI1_MRST		O3	Slave SPI data output	
IOM_MON2_1			Monitor input 2	
IOM_REF2_1			Reference input 2	
ERAY0_TXDA		O4	Transmit Channel A	
—		O5	Reserved	
GETH_TXD0		O6	Transmit Data	
CCU60_COUT62		O7	T12 PWM channel 62	
IOM_MON1_5			Monitor input 1	
IOM_REF1_1			Reference input 1	

## Pin Definition and Functions BGA516 Package Variant Pin Configuration

Table 2-5 Port 11 Functions (cont'd)

Ball	Symbol	Ctrl.	Buffer Type	Function
J15	P11.4	I	RFAST / PU1 / VFLEX / ES	General-purpose input
	GTM_TIM4_IN2_5			Mux input channel 2 of TIM module 4
	GTM_TIM2_IN2_6			Mux input channel 2 of TIM module 2
	GETH_RXCLKB			Receive Clock MII
	P11.4	O0		General-purpose output
	GTM_TOUT121	O1		GTM muxed output
	ASCLIN3_ASCLK	O2		Shift clock output
	—	O3		Reserved
	—	O4		Reserved
	CAN13_TXD	O5		CAN transmit output node 3
	GETH_TXER	O6		Transmit Error MII
	GETH_TXCLK	O7		Transmit Clock Output for RGMII
J13	P11.5	I	SLOW / RGMII_In put / PU1 / VFLEX / ES	General-purpose input
	GTM_TIM4_IN3_5			Mux input channel 3 of TIM module 4
	GTM_TIM2_IN3_8			Mux input channel 3 of TIM module 2
	GETH_TXCLKA			Transmit Clock Input for MII
	GETH_GREFCLK			Gigabit Reference Clock input for RGMII (125 MHz high precision)
	P11.5	O0		General-purpose output
	GTM_TOUT122	O1		GTM muxed output
	—	O2		Reserved
	—	O3		Reserved
	—	O4		Reserved
	CAN20_TXD	O5		CAN transmit output node 0
	—	O6		Reserved
	—	O7		Reserved

## Pin Definition and Functions BGA516 Package Variant Pin Configuration

Table 2-5 Port 11 Functions (cont'd)

Ball	Symbol	Ctrl.	Buffer Type	Function
J14	P11.6	I	RFAST / PU1 / VFLEX / ES	General-purpose input
	GTM_TIM3_IN3_2			Mux input channel 3 of TIM module 3
	GTM_TIM2_IN3_2			Mux input channel 3 of TIM module 2
	QSPI1_SCLKB			Slave SPI clock inputs
	P11.6	O0		General-purpose output
	GTM_TOUT97	O1		GTM muxed output
	ERAY0_TXENB	O2		Transmit Enable Channel B
	QSPI1_SCLK	O3		Master SPI clock output
	ERAY0_TXENA	O4		Transmit Enable Channel A
	MSC0_FCLP	O5		Shift-clock direct part of the differential signal
	GETH_TXEN	O6		Transmit Enable MII and RMII
	GETH_TCTL		Transmit Control for RGMII	
	CCU60_COUT61	O7		T12 PWM channel 61
	IOM_MON1_4		Monitor input 1	
IOM_REF1_2	Reference input 1			
K13	P11.7	I	SLOW / RGMII_In put / PU1 / VFLEX / ES	General-purpose input
	GTM_TIM4_IN4_5			Mux input channel 4 of TIM module 4
	GTM_TIM2_IN4_7			Mux input channel 4 of TIM module 2
	GETH_RXD3A			Receive Data 3 MII and RGMII (RGMII can use RXD3A only)
	CAN11_RXDD			CAN receive input node 1
	P11.7	O0		General-purpose output
	GTM_TOUT123	O1		GTM muxed output
	—	O2		Reserved
	—	O3		Reserved
	—	O4		Reserved
	—	O5		Reserved
	—	O6		Reserved
	—	O7		Reserved

## Pin Definition and Functions BGA516 Package Variant Pin Configuration

Table 2-5 Port 11 Functions (cont'd)

Ball	Symbol	Ctrl.	Buffer Type	Function
K12	P11.8	I	SLOW / RGMII_ Input / PU1 / VFLEX / ES	General-purpose input
	GTM_TIM4_IN5_5			Mux input channel 5 of TIM module 4
	GTM_TIM2_IN5_8			Mux input channel 5 of TIM module 2
	GETH_RXD2A			Receive Data 2 MII and RGMII (RGMII can use RXD2A only)
	CAN12_RXDD			CAN receive input node 2
	P11.8	O0	General-purpose output	
	GTM_TOUT124	O1	GTM muxed output	
	—	O2	Reserved	
	—	O3	Reserved	
	—	O4	Reserved	
	—	O5	Reserved	
	—	O6	Reserved	
—	O7	Reserved		
F14	P11.9	I	FAST / RGMII_ Input / PU1 / VFLEX / ES	General-purpose input
	GTM_TIM3_IN4_2			Mux input channel 4 of TIM module 3
	GTM_TIM2_IN4_2			Mux input channel 4 of TIM module 2
	QSPI1_MTSRB			Slave SPI data input
	ERAY0_RXDA1			Receive Channel A1
	GETH_RXD1A			Receive Data 1 MII, RMII and RGMII (RGMII can use RXD1A only)
	P11.9	O0	General-purpose output	
	GTM_TOUT98	O1	GTM muxed output	
	—	O2	Reserved	
	QSPI1_MTSR	O3	Master SPI data output	
	—	O4	Reserved	
	MSC0_SOP	O5	Data output - direct part of the differential signal	
	—	O6	Reserved	
	CCU60_COUT60	O7	T12 PWM channel 60	
	IOM_MON1_3		Monitor input 1	
IOM_REF1_3		Reference input 1		

## Pin Definition and Functions BGA516 Package Variant Pin Configuration

Table 2-5 Port 11 Functions (cont'd)

Ball	Symbol	Ctrl.	Buffer Type	Function	
G14	P11.10	I	FAST / RGMII_Input / PU1 / VFLEX / ES	General-purpose input	
	GTM_TIM3_IN5_2			Mux input channel 5 of TIM module 3	
	GTM_TIM2_IN5_2			Mux input channel 5 of TIM module 2	
	GTM_TIM2_IN0_9			Mux input channel 0 of TIM module 2	
	CAN03_RXDD			CAN receive input node 3	
	ERAY0_RXDB1			Receive Channel B1	
	ASCLIN1_ARXE			Receive input	
	SCU_E_REQ6_3			ERU Channel 6 inputs 0 to 5 (0 is the LSB and 5 is the MSB)	
	MSC0_SDI0			Upstream asynchronous input signal	
	GETH_RXD0A			Receive Data 0 MII, RMI and RGMII (RGMII can use RXD0A only)	
	QSPI1_SLSIA			Slave select input	
	P11.10			O0	General-purpose output
	GTM_TOUT99			O1	GTM muxed output
	—	O2	Reserved		
	QSPI0_SLSO3	O3	Master slave select output		
	QSPI1_SLSO3	O4	Master slave select output		
	—	O5	Reserved		
	—	O6	Reserved		
	CCU60_CC62	O7	T12 PWM channel 62		
	IOM_MON1_0		Monitor input 1		
IOM_REF1_4		Reference input 1			

## Pin Definition and Functions BGA516 Package Variant Pin Configuration

Table 2-5 Port 11 Functions (cont'd)

Ball	Symbol	Ctrl.	Buffer Type	Function	
F13	P11.11	I	FAST / RGMII_In put / PU1 / VFLEX / ES	General-purpose input	
	GTM_TIM3_IN6_2			Mux input channel 6 of TIM module 3	
	GTM_TIM3_IN0_14			Mux input channel 0 of TIM module 3	
	GTM_TIM2_IN6_2			Mux input channel 6 of TIM module 2	
	GETH_CRSDVA			Carrier Sense / Data Valid combi-signal for RMII	
	GETH_RXDVA			Receive Data Valid MII	
	GETH_CRSB			Carrier Sense MII	
	GETH_RCTLA			Receive Control for RGMII	
	P11.11			O0	General-purpose output
	GTM_TOUT100			O1	GTM muxed output
	—			O2	Reserved
	QSPIO_SLSO4			O3	Master slave select output
	QSPI1_SLSO4			O4	Master slave select output
	MSC0_EN0			O5	Chip Select
	ERAY0_TXENB			O6	Transmit Enable Channel B
	CCU60_CC61			O7	T12 PWM channel 61
	IOM_MON1_1				Monitor input 1
IOM_REF1_5		Reference input 1			
G13	P11.12	I	FAST / RGMII_In put / PU1 / VFLEX / ES	General-purpose input	
	GTM_TIM3_IN7_2			Mux input channel 7 of TIM module 3	
	GTM_TIM2_IN7_2			Mux input channel 7 of TIM module 2	
	GETH_REFCLKA			Reference Clock input for RMII (50 MHz)	
	GETH_TXCLKB			Transmit Clock Input for MII	
	GETH_RXCLKA			Receive Clock MII	
	P11.12			O0	General-purpose output
	GTM_TOUT101			O1	GTM muxed output
	ASCLIN1_ATX			O2	Transmit output
	IOM_MON2_13				Monitor input 2
	IOM_REF2_13				Reference input 2
	GTM_CLK2			O3	CGM generated clock
	ERAY0_TXDB			O4	Transmit Channel B
	CAN03_TXD			O5	CAN transmit output node 3
	IOM_MON2_8				Monitor input 2
	IOM_REF2_8				Reference input 2
	CCU_EXTCLK1			O6	External Clock 1
CCU60_CC60	O7	T12 PWM channel 60			
IOM_MON1_2		Monitor input 1			
IOM_REF1_6		Reference input 1			

## Pin Definition and Functions BGA516 Package Variant Pin Configuration

Table 2-5 Port 11 Functions (cont'd)

Ball	Symbol	Ctrl.	Buffer Type	Function
K11	P11.13	I	SLOW / PU1 / VFLEX / ES	General-purpose input
	GTM_TIM4_IN6_5			Mux input channel 6 of TIM module 4
	GTM_TIM2_IN6_7			Mux input channel 6 of TIM module 2
	GETH_RXERA			Receive Error MII
	I2C1_SDAA			Serial Data Input 0
	CAN13_RXDD			CAN receive input node 3
	P11.13			O0
	GTM_TOUT125	O1	GTM muxed output	
	—	O2	Reserved	
	—	O3	Reserved	
	—	O4	Reserved	
	—	O5	Reserved	
	I2C1_SDA	O6	Serial Data Output	
	—	O7	Reserved	
J12	P11.14	I	SLOW / PU1 / VFLEX / ES	General-purpose input
	GTM_TIM4_IN7_4			Mux input channel 7 of TIM module 4
	GTM_TIM2_IN7_8			Mux input channel 7 of TIM module 2
	GETH_CRSDVB			Carrier Sense / Data Valid combi-signal for RMII
	GETH_RXDVB			Receive Data Valid MII
	GETH_CRSA			Carrier Sense MII
	I2C1_SCLA			Serial Clock Input 0
	CAN20_RXDF	CAN receive input node 0		
	P11.14	O0	General-purpose output	
	GTM_TOUT126	O1	GTM muxed output	
	—	O2	Reserved	
	—	O3	Reserved	
	—	O4	Reserved	
	—	O5	Reserved	
I2C1_SCL	O6	Serial Clock Output		
—	O7	Reserved		

## Pin Definition and Functions BGA516 Package Variant Pin Configuration

Table 2-5 Port 11 Functions (cont'd)

Ball	Symbol	Ctrl.	Buffer Type	Function
J11	P11.15	I	SLOW / PU1 / VFLEX / ES	General-purpose input
	GTM_TIM4_IN7_5			Mux input channel 7 of TIM module 4
	GTM_TIM0_IN7_8			Mux input channel 7 of TIM module 0
	GETH_COLA			Collision MII
	P11.15	O0		General-purpose output
	GTM_TOUT127	O1		GTM muxed output
	—	O2		Reserved
	—	O3		Reserved
	—	O4		Reserved
	—	O5		Reserved
	—	O6		Reserved
	—	O7		Reserved

Table 2-6 Port 12 Functions

Ball	Symbol	Ctrl.	Buffer Type	Function
K17	P12.0	I	SLOW / PU1 / VFLEX / ES	General-purpose input
	GTM_TIM4_IN0_5			Mux input channel 0 of TIM module 4
	GTM_TIM3_IN0_7			Mux input channel 0 of TIM module 3
	CAN00_RXDC			CAN receive input node 0
	GETH_RXCLKC			Receive Clock MII
	GTM_DTMA4_0			CDTM4_DTM4
	P12.0	O0		General-purpose output
	GTM_TOUT128	O1		GTM muxed output
	—	O2		Reserved
	—	O3		Reserved
	—	O4		Reserved
	—	O5		Reserved
	GETH_MDC	O6		MDIO clock
—	O7	Reserved		

## Pin Definition and Functions BGA516 Package Variant Pin Configuration

Table 2-6 Port 12 Functions (cont'd)

Ball	Symbol	Ctrl.	Buffer Type	Function
K16	P12.1	I	SLOW / PU1 / VFLEX / ES	General-purpose input
	GTM_TIM4_IN1_6			Mux input channel 1 of TIM module 4
	GTM_TIM3_IN1_6			Mux input channel 1 of TIM module 3
	GETH_MDIOC			MDIO Input
	P12.1	O0	General-purpose output	
	GTM_TOUT129	O1	GTM muxed output	
	ASCLIN3_ASLSO	O2	Slave select signal output	
	—	O3	Reserved	
	—	O4	Reserved	
	CAN00_TXD	O5	CAN transmit output node 0	
	IOM_MON2_5		Monitor input 2	
	IOM_REF2_5		Reference input 2	
	—	O6	Reserved	
	—	O7	Reserved	
	GETH_MDIO	O	MDIO Output	

Table 2-7 Port 13 Functions

Ball	Symbol	Ctrl.	Buffer Type	Function
G17	P13.0	I	LVDS_TX / FAST / PU1 / VEXT / ES6	General-purpose input
	GTM_TIM3_IN5_3			Mux input channel 5 of TIM module 3
	GTM_TIM2_IN5_3			Mux input channel 5 of TIM module 2
	ASCLIN10_ARXC			Receive input
	ASCLIN21_ARXA			Receive input
	P13.0	O0	General-purpose output	
	GTM_TOUT91	O1	GTM muxed output	
	ASCLIN10_ATX	O2	Transmit output	
	QSPI2_SCLKN	O3	Master SPI clock output (LVDS N line)	
	MSC0_EN1	O4	Chip Select	
	MSC0_FCLN	O5	Shift-clock inverted part of the differential signal	
	—	O6	Reserved	
	CAN10_TXD	O7	CAN transmit output node 0	

## Pin Definition and Functions BGA516 Package Variant Pin Configuration

Table 2-7 Port 13 Functions (cont'd)

Ball	Symbol	Ctrl.	Buffer Type	Function
F17	P13.1	I	LVDS_TX / FAST / PU1 / VEXT / ES6	General-purpose input
	GTM_TIM3_IN6_3			Mux input channel 6 of TIM module 3
	GTM_TIM2_IN6_3			Mux input channel 6 of TIM module 2
	I2C0_SCLB			Serial Clock Input 1
	CAN10_RXDD			CAN receive input node 0
	ASCLIN10_ARXD			Receive input
	P13.1			O0
	GTM_TOUT92	O1	GTM muxed output	
	—	O2	Reserved	
	QSPI2_SCLKP	O3	Master SPI clock output (LVDS P line)	
	—	O4	Reserved	
	MSC0_FCLP	O5	Shift-clock direct part of the differential signal	
	I2C0_SCL	O6	Serial Clock Output	
	—	O7	Reserved	
G16	P13.2	I	LVDS_TX / FAST / PU1 / VEXT / ES6	General-purpose input
	GTM_TIM3_IN7_3			Mux input channel 7 of TIM module 3
	GTM_TIM2_IN7_3			Mux input channel 7 of TIM module 2
	GPT120_CAPINA			Trigger input to capture value of timer T5 into CAPREL register
	I2C0_SDAB		Serial Data Input 1	
	P13.2	O0	General-purpose output	
	GTM_TOUT93	O1	GTM muxed output	
	ASCLIN10_ASCLK	O2	Shift clock output	
	QSPI2_MTSRN	O3	Master SPI data output (LVDS N line)	
	MSC0_FCLP	O4	Shift-clock direct part of the differential signal	
	MSC0_SON	O5	Data output - inverted part of the differential signal	
	I2C0_SDA	O6	Serial Data Output	
	ASCLIN21_ATX	O7	Transmit output	

## Pin Definition and Functions BGA516 Package Variant Pin Configuration

Table 2-7 Port 13 Functions (cont'd)

Ball	Symbol	Ctrl.	Buffer Type	Function
F16	P13.3	I	LVDS_TX / FAST / PU1 / VEXT / ES6	General-purpose input
	GTM_TIM3_IN0_3			Mux input channel 0 of TIM module 3
	GTM_TIM2_IN0_3			Mux input channel 0 of TIM module 2
	ASCLIN21_ARXB			Receive input
	P13.3	O0		General-purpose output
	GTM_TOUT94	O1		GTM muxed output
	ASCLIN10_ASLSO	O2		Slave select signal output
	QSPI2_MTSRP	O3		Master SPI data output (LVDS P line)
	—	O4		Reserved
	MSC0_SOP	O5		Data output - direct part of the differential signal
	ASCLIN21_ATX	O6		Transmit output
—	O7	Reserved		
B16	P13.4	I	LVDS_TX / FAST / PU1 / VEXT / ES6	General-purpose input
	GTM_TIM6_IN0_4			Mux input channel 0 of TIM module 6
	GTM_TIM5_IN3_4			Mux input channel 3 of TIM module 5
	GTM_TIM3_IN3_8			Mux input channel 3 of TIM module 3
	P13.4	O0		General-purpose output
	GTM_TOUT253	O1		GTM muxed output
	—	O2		Reserved
	—	O3		Reserved
	MSC2_EN0	O4		Chip Select
	MSC2_FCLN	O5		Shift-clock inverted part of the differential signal
	—	O6		Reserved
CAN23_TXD	O7	CAN transmit output node 3		
A16	P13.5	I	LVDS_TX / FAST / PU1 / VEXT / ES6	General-purpose input
	GTM_TIM6_IN1_4			Mux input channel 1 of TIM module 6
	GTM_TIM5_IN4_4			Mux input channel 4 of TIM module 5
	GTM_TIM3_IN4_9			Mux input channel 4 of TIM module 3
	CAN23_RXDD			CAN receive input node 3
	P13.5	O0		General-purpose output
	GTM_TOUT254	O1		GTM muxed output
	—	O2		Reserved
	—	O3		Reserved
	—	O4		Reserved
	MSC2_FCLP	O5		Shift-clock direct part of the differential signal
—	O6	Reserved		
—	O7	Reserved		

## Pin Definition and Functions BGA516 Package Variant Pin Configuration

Table 2-7 Port 13 Functions (cont'd)

Ball	Symbol	Ctrl.	Buffer Type	Function
B15	P13.6	I	LVDS_TX / FAST / PU1 / VEXT / ES6	General-purpose input
	GTM_TIM6_IN2_4			Mux input channel 2 of TIM module 6
	GTM_TIM5_IN5_4			Mux input channel 5 of TIM module 5
	GTM_TIM3_IN5_10			Mux input channel 5 of TIM module 3
	P13.6	O0		General-purpose output
	GTM_TOUT255	O1		GTM muxed output
	—	O2		Reserved
	—	O3		Reserved
	—	O4		Reserved
	MSC2_SON	O5		Data output - inverted part of the differential signal
	—	O6		Reserved
	—	O7		Reserved
A15	P13.7	I	LVDS_TX / FAST / PU1 / VEXT / ES6	General-purpose input
	GTM_TIM6_IN3_4			Mux input channel 3 of TIM module 6
	GTM_TIM5_IN6_4			Mux input channel 6 of TIM module 5
	GTM_TIM3_IN6_10			Mux input channel 6 of TIM module 3
	P13.7	O0		General-purpose output
	GTM_TOUT256	O1		GTM muxed output
	—	O2		Reserved
	—	O3		Reserved
	—	O4		Reserved
	MSC2_SOP	O5		Data output - direct part of the differential signal
	—	O6		Reserved
	—	O7		Reserved

## Pin Definition and Functions BGA516 Package Variant Pin Configuration

Table 2-7 Port 13 Functions (cont'd)

Ball	Symbol	Ctrl.	Buffer Type	Function	
A14	P13.9	I	FAST / PU1 / VEXT / ES	General-purpose input	
	GTM_TIM6_IN4_4			Mux input channel 4 of TIM module 6	
	GTM_TIM4_IN7_6			Mux input channel 7 of TIM module 4	
	GTM_TIM2_IN7_12			Mux input channel 7 of TIM module 2	
	I2C1_SCLB			Serial Clock Input 1	
	P13.9			O0	General-purpose output
	GTM_TOUT248			O1	GTM muxed output
	ASCLIN3_ATX			O2	Transmit output
	IOM_MON2_15				Monitor input 2
	IOM_REF2_15				Reference input 2
	—			O3	Reserved
	—			O4	Reserved
	CAN21_TXD			O5	CAN transmit output node 1
	I2C1_SCL			O6	Serial Clock Output
—	O7	Reserved			
B13	P13.10	I	SLOW / PU1 / VEXT / ES	General-purpose input	
	GTM_TIM6_IN5_4			Mux input channel 5 of TIM module 6	
	GTM_TIM5_IN1_5			Mux input channel 1 of TIM module 5	
	GTM_TIM3_IN1_8			Mux input channel 1 of TIM module 3	
	PSI5_RX3A			RXD inputs (receive data) channel 3	
	P13.10			O0	General-purpose output
	GTM_TOUT251			O1	GTM muxed output
	ASCLIN0_ATX			O2	Transmit output
	IOM_MON2_12				Monitor input 2
	IOM_REF2_12				Reference input 2
	—			O3	Reserved
	—			O4	Reserved
	—			O5	Reserved
	—			O6	Reserved
—	O7	Reserved			

## Pin Definition and Functions BGA516 Package Variant Pin Configuration

Table 2-7 Port 13 Functions (cont'd)

Ball	Symbol	Ctrl.	Buffer Type	Function
A13	P13.11	I	SLOW / PU1 / VEXT / ES	General-purpose input
	GTM_TIM6_IN6_4			Mux input channel 6 of TIM module 6
	GTM_TIM5_IN0_9			Mux input channel 0 of TIM module 5
	GTM_TIM3_IN0_9			Mux input channel 0 of TIM module 3
	ASCLIN0_ARXE			Receive input
	ASCLIN7_ARXD			Receive input
	P13.11	O0		General-purpose output
	GTM_TOUT250	O1		GTM muxed output
	—	O2		Reserved
	—	O3		Reserved
	PSI5_TX3	O4		TXD outputs (send data)
	—	O5		Reserved
	—	O6		Reserved
	—	O7		Reserved
B12	P13.12	I	SLOW / PU1 / VEXT / ES	General-purpose input
	GTM_TIM6_IN7_4			Mux input channel 7 of TIM module 6
	GTM_TIM4_IN0_6			Mux input channel 0 of TIM module 4
	GTM_TIM0_IN0_11			Mux input channel 0 of TIM module 0
	ASCLIN3_ARXH			Receive input
	I2C1_SDAB			Serial Data Input 1
	CAN21_RXDB	CAN receive input node 1		
	P13.12	O0		General-purpose output
	GTM_TOUT249	O1		GTM muxed output
	ASCLIN7_ATX	O2		Transmit output
	—	O3		Reserved
	—	O4		Reserved
	—	O5		Reserved
	I2C1_SDA	O6		Serial Data Output
—	O7	Reserved		

## Pin Definition and Functions BGA516 Package Variant Pin Configuration

Table 2-7 Port 13 Functions (cont'd)

Ball	Symbol	Ctrl.	Buffer Type	Function
A12	P13.13	I	SLOW / PU1 / VEXT / ES	General-purpose input
	GTM_TIM5_IN5_5			Mux input channel 5 of TIM module 5
	GTM_TIM3_IN5_9			Mux input channel 5 of TIM module 3
	MSC2_INJ0			Injection signal from port
	PSI5_RX3B			RXD inputs (receive data) channel 3
	P13.13	O0		General-purpose output
	GTM_TOUT262	O1		GTM muxed output
	ASCLIN7_ASCLK	O2		Shift clock output
	—	O3		Reserved
	—	O4		Reserved
	—	O5		Reserved
	—	O6		Reserved
	—	O7		Reserved
B11	P13.14	I	SLOW / PU1 / VEXT / ES	General-purpose input
	GTM_TIM5_IN2_4			Mux input channel 2 of TIM module 5
	GTM_TIM3_IN2_7			Mux input channel 2 of TIM module 3
	P13.14	O0		General-purpose output
	GTM_TOUT252	O1		GTM muxed output
	—	O2		Reserved
	—	O3		Reserved
	—	O4		Reserved
	—	O5		Reserved
	—	O6		Reserved
	—	O7		Reserved
A11	P13.15	I	SLOW / PU1 / VEXT / ES	General-purpose input
	GTM_TIM5_IN7_4			Mux input channel 7 of TIM module 5
	GTM_TIM3_IN7_9			Mux input channel 7 of TIM module 3
	P13.15	O0		General-purpose output
	GTM_TOUT264	O1		GTM muxed output
	ASCLIN7_ASLSO	O2		Slave select signal output
	—	O3		Reserved
	PSI5_TX3	O4		TXD outputs (send data)
	—	O5		Reserved
	—	O6		Reserved
—	O7	Reserved		

## Pin Definition and Functions BGA516 Package Variant Pin Configuration

Table 2-8 Port 14 Functions

Ball	Symbol	Ctrl.	Buffer Type	Function
G21	P14.0	I	FAST / PU1 / VEXT / ES2	<b>General-purpose input</b>
	GTM_TIM1_IN3_5			<b>Mux input channel 3 of TIM module 1</b>
	GTM_TIM0_IN3_5			<b>Mux input channel 3 of TIM module 0</b>
	SENT_SENT17D			<b>Receive input channel 17</b>
	P14.0	O0		<b>General-purpose output</b>
	GTM_TOUT80	O1		<b>GTM muxed output</b>
	ASCLIN0_ATX	O2		<b>Transmit output</b>
	IOM_MON2_12			<b>Monitor input 2</b>
	IOM_REF2_12			<b>Reference input 2</b>
	ERAY0_TXDA	O3		<b>Transmit Channel A</b>
	ERAY0_TXDB	O4		<b>Transmit Channel B</b>
	CAN01_TXD	O5		<b>CAN transmit output node 1</b>
	IOM_MON2_6			<b>Monitor input 2</b>
	IOM_REF2_6			<b>Reference input 2</b>
	ASCLIN0_ASCLK	O6		<b>Shift clock output</b>
	CCU60_COUT62	O7		<b>T12 PWM channel 62</b>
	IOM_MON1_5			<b>Monitor input 1</b>
	IOM_REF1_1			<b>Reference input 1</b>

## Pin Definition and Functions BGA516 Package Variant Pin Configuration

Table 2-8 Port 14 Functions (cont'd)

Ball	Symbol	Ctrl.	Buffer Type	Function
F20	P14.1	I	FAST / PU1 / VEXT / ES2	General-purpose input
	GTM_TIM1_IN4_3			Mux input channel 4 of TIM module 1
	GTM_TIM0_IN4_3			Mux input channel 4 of TIM module 0
	ERAY0_RXDA3			Receive Channel A3
	ASCLIN0_ARXA			Receive input
	SENT_SENT18D			Receive input channel 18
	ERAY0_RXDB3			Receive Channel B3
	CAN01_RXDB			CAN receive input node 1
	SCU_E_REQ3_1			ERU Channel 3 inputs 0 to 5 (0 is the LSB and 5 is the MSB)
	PMS_PINAWKP			PINA ( P14.1) pin input
	P14.1	O0	General-purpose output	
	GTM_TOUT81	O1	GTM muxed output	
	ASCLIN0_ATX	O2	Transmit output	
	IOM_MON2_12		Monitor input 2	
	IOM_REF2_12		Reference input 2	
	—	O3	Reserved	
	—	O4	Reserved	
	—	O5	Reserved	
	—	O6	Reserved	
	CCU60_COUT63	O7	T13 PWM channel 63	
IOM_MON1_6		Monitor input 1		
IOM_REF1_0		Reference input 1		
K18	P14.2	I	SLOW / PU2 / VEXT / ES	General-purpose input
	GTM_TIM1_IN5_3			Mux input channel 5 of TIM module 1
	GTM_TIM0_IN5_3			Mux input channel 5 of TIM module 0
	PMS_HWCFG2IN			HWCFG2 pin input
	P14.2	O0	General-purpose output	
	GTM_TOUT82	O1	GTM muxed output	
	ASCLIN2_ATX	O2	Transmit output	
	IOM_MON2_14		Monitor input 2	
	IOM_REF2_14		Reference input 2	
	QSPI2_SLSO1	O3	Master slave select output	
	—	O4	Reserved	
	—	O5	Reserved	
	ASCLIN2_ASCLK	O6	Shift clock output	
	—	O7	Reserved	

## Pin Definition and Functions BGA516 Package Variant Pin Configuration

Table 2-8 Port 14 Functions (cont'd)

Ball	Symbol	Ctrl.	Buffer Type	Function
G19	P14.3	I	SLOW / PU2 / VEXT / ES	General-purpose input
	GTM_TIM1_IN6_3			Mux input channel 6 of TIM module 1
	GTM_TIM0_IN6_3			Mux input channel 6 of TIM module 0
	PMS_HWCFG3IN			HWCFG3 pin input
	ASCLIN2_ARXA			Receive input
	MSC0_SDI2			Upstream assynchronous input signal
	SCU_E_REQ1_0			ERU Channel 1 inputs 0 to 5 (0 is the LSB and 5 is the MSB)
	P14.3	O0	General-purpose output	
	GTM_TOUT83	O1	GTM muxed output	
	ASCLIN2_ATX	O2	Transmit output	
	IOM_MON2_14		Monitor input 2	
	IOM_REF2_14		Reference input 2	
	QSPI2_SLSO3	O3	Master slave select output	
	ASCLIN1_ASLSO	O4	Slave select signal output	
	ASCLIN3_ASLSO	O5	Slave select signal output	
	—	O6	Reserved	
	—	O7	Reserved	
G20	P14.4	I	SLOW / PU2 / VEXT / ES	General-purpose input
	GTM_TIM1_IN7_2			Mux input channel 7 of TIM module 1
	GTM_TIM0_IN7_2			Mux input channel 7 of TIM module 0
	PMS_HWCFG6IN			HWCFG6 pin input
	GTM_DTMT0_0			CDTM0_DTM0
	P14.4	O0	General-purpose output	
	GTM_TOUT84	O1	GTM muxed output	
	—	O2	Reserved	
	—	O3	Reserved	
	—	O4	Reserved	
	—	O5	Reserved	
	GETH_PPS	O6	Pulse Per Second	
	—	O7	Reserved	

## Pin Definition and Functions BGA516 Package Variant Pin Configuration

Table 2-8 Port 14 Functions (cont'd)

Ball	Symbol	Ctrl.	Buffer Type	Function
F19	P14.5	I	FAST / PU2 / VEXT / ES	General-purpose input
	GTM_TIM1_IN0_4			Mux input channel 0 of TIM module 1
	GTM_TIM0_IN0_4			Mux input channel 0 of TIM module 0
	PMS_HWCFG1IN			HWCFG1 pin input
	GTM_DTMA2_0			CDTM2_DTM4
	P14.5			O0
	GTM_TOUT85	O1	GTM muxed output	
	—	O2	Reserved	
	—	O3	Reserved	
	—	O4	Reserved	
	—	O5	Reserved	
	ERAY0_TXDB	O6	Transmit Channel B	
	ERAY1_TXDB	O7	Transmit Channel B	
G18	P14.6	I	FAST / PU1 / VEXT / ES	General-purpose input
	GTM_TIM1_IN1_4			Mux input channel 1 of TIM module 1
	GTM_TIM0_IN1_4			Mux input channel 1 of TIM module 0
	P14.6	O0	General-purpose output	
	GTM_TOUT86	O1	GTM muxed output	
	—	O2	Reserved	
	QSPI2_SLSO2	O3	Master slave select output	
	CAN13_TXD	O4	CAN transmit output node 3	
	—	O5	Reserved	
	ERAY0_TXENB	O6	Transmit Enable Channel B	
	ERAY1_TXENB	O7	Transmit Enable Channel B	

## Pin Definition and Functions BGA516 Package Variant Pin Configuration

Table 2-8 Port 14 Functions (cont'd)

Ball	Symbol	Ctrl.	Buffer Type	Function	
J18	P14.7	I	SLOW / PU1 / VEXT / ES	General-purpose input	
	GTM_TIM4_IN7_10			Mux input channel 7 of TIM module 4	
	GTM_TIM1_IN0_5			Mux input channel 0 of TIM module 1	
	GTM_TIM0_IN0_5			Mux input channel 0 of TIM module 0	
	ERAY0_RXDB0			Receive Channel B0	
	ERAY1_RXDB0			Receive Channel B0	
	CAN10_RXDB			CAN receive input node 0	
	CAN13_RXDA			CAN receive input node 3	
	ASCLIN9_ARXC			Receive input	
	ASCLIN20_ARXA			Receive input	
	P14.7			O0	General-purpose output
	GTM_TOUT87			O1	GTM muxed output
	ASCLIN0_ARTS	O2	Ready to send output		
	QSPI2_SLSO4	O3	Master slave select output		
	ASCLIN9_ATX	O4	Transmit output		
	—	O5	Reserved		
	—	O6	Reserved		
	ASCLIN20_ATX	O7	Transmit output		
F18	P14.8	I	SLOW / PU1 / VEXT / ES	General-purpose input	
	GTM_TIM3_IN2_3			Mux input channel 2 of TIM module 3	
	GTM_TIM2_IN2_3			Mux input channel 2 of TIM module 2	
	ERAY0_RXDA0			Receive Channel A0	
	CAN02_RXDD			CAN receive input node 2	
	ASCLIN1_ARXD			Receive input	
	ERAY1_RXDA0			Receive Channel A0	
	P14.8	O0	General-purpose output		
	GTM_TOUT88	O1	GTM muxed output		
	ASCLIN5_ASLSO	O2	Slave select signal output		
	ASCLIN7_ASLSO	O3	Slave select signal output		
	—	O4	Reserved		
	—	O5	Reserved		
	—	O6	Reserved		
	ASCLIN20_ATX	O7	Transmit output		

## Pin Definition and Functions BGA516 Package Variant Pin Configuration

Table 2-8 Port 14 Functions (cont'd)

Ball	Symbol	Ctrl.	Buffer Type	Function	
J17	P14.9	I	LVDS_R X/FAST/ PU1/ VEXT/ ES	General-purpose input	
	GTM_TIM3_IN3_3			Mux input channel 3 of TIM module 3	
	GTM_TIM2_IN3_3			Mux input channel 3 of TIM module 2	
	ASCLIN0_ACTSA			Clear to send input	
	QSPI2_MRSTFN			Master SPI data input (LVDS N line)	
	ASCLIN9_ARXD			Receive input	
	ASCLIN20_ARXB			Receive input	
	P14.9			O0	General-purpose output
	GTM_TOUT89			O1	GTM muxed output
	CAN23_TXD			O2	CAN transmit output node 3
	MSC0_EN1			O3	Chip Select
	CAN10_TXD			O4	CAN transmit output node 0
	ERAY0_TXENB			O5	Transmit Enable Channel B
	ERAY0_TXENA			O6	Transmit Enable Channel A
ERAY1_TXENA	O7	Transmit Enable Channel A			
J16	P14.10	I	LVDS_R X/FAST/ PU1/ VEXT/ ES	General-purpose input	
	GTM_TIM3_IN4_3			Mux input channel 4 of TIM module 3	
	GTM_TIM2_IN4_3			Mux input channel 4 of TIM module 2	
	CAN23_RXDA			CAN receive input node 3	
	QSPI2_MRSTFP			Master SPI data input (LVDS P line)	
	P14.10			O0	General-purpose output
	GTM_TOUT90			O1	GTM muxed output
	—			O2	Reserved
	MSC0_EN0			O3	Chip Select
	ASCLIN1_ATX			O4	Transmit output
	IOM_MON2_13			O5	Monitor input 2
	IOM_REF2_13				Reference input 2
	CAN02_TXD			O5	CAN transmit output node 2
	IOM_MON2_7			O6	Monitor input 2
	IOM_REF2_7				Reference input 2
	ERAY0_TXDA			O6	Transmit Channel A
ERAY1_TXDA	O7	Transmit Channel A			

## Pin Definition and Functions BGA516 Package Variant Pin Configuration

Table 2-8 Port 14 Functions (cont'd)

Ball	Symbol	Ctrl.	Buffer Type	Function
A20	P14.11	I	SLOW / PU1 / VEXT / ES	General-purpose input
	GTM_TIM5_IN1_4			Mux input channel 1 of TIM module 5
	GTM_TIM3_IN1_9			Mux input channel 1 of TIM module 3
	MSC2_SD11			Upstream asynchronous input signal
	P14.11	O0		General-purpose output
	GTM_TOUT258	O1		GTM muxed output
	—	O2		Reserved
	—	O3		Reserved
	MSC2_EN2	O4		Chip Select
	MSC2_SOP	O5		Data output - direct part of the differential signal
	—	O6		Reserved
	—	O7		Reserved
B19	P14.12	I	SLOW / PU1 / VEXT / ES	General-purpose input
	GTM_TIM6_IN4_3			Mux input channel 4 of TIM module 6
	GTM_TIM5_IN4_5			Mux input channel 4 of TIM module 5
	GTM_TIM3_IN4_8			Mux input channel 4 of TIM module 3
	MSC2_SD10			Upstream asynchronous input signal
	P14.12	O0		General-purpose output
	GTM_TOUT261	O1		GTM muxed output
	ASCLIN5_ASCLK	O2		Shift clock output
	ASCLIN7_ASCLK	O3		Shift clock output
	—	O4		Reserved
	—	O5		Reserved
	—	O6		Reserved
—	O7	Reserved		
A19	P14.13	I	FAST / PU1 / VEXT / ES	General-purpose input
	GTM_TIM6_IN5_3			Mux input channel 5 of TIM module 6
	GTM_TIM5_IN3_5			Mux input channel 3 of TIM module 5
	GTM_TIM3_IN3_6			Mux input channel 3 of TIM module 3
	P14.13	O0		General-purpose output
	GTM_TOUT260	O1		GTM muxed output
	—	O2		Reserved
	—	O3		Reserved
	MSC2_EN1	O4		Chip Select
	CAN22_TXD	O5		CAN transmit output node 2
	—	O6		Reserved
	—	O7		Reserved

## Pin Definition and Functions BGA516 Package Variant Pin Configuration

Table 2-8 Port 14 Functions (cont'd)

Ball	Symbol	Ctrl.	Buffer Type	Function	
B18	P14.14	I	FAST / PU1 / VEXT / ES	General-purpose input	
	GTM_TIM6_IN6_3			Mux input channel 6 of TIM module 6	
	GTM_TIM5_IN2_3			Mux input channel 2 of TIM module 5	
	GTM_TIM3_IN2_8			Mux input channel 2 of TIM module 3	
	CAN22_RXDD			CAN receive input node 2	
	P14.14			O0	General-purpose output
	GTM_TOUT259			O1	GTM muxed output
	ASCLIN5_ATX			O2	Transmit output
	ASCLIN7_ATX			O3	Transmit output
	MSC2_EN0			O4	Chip Select
	CAN23_TXD			O5	CAN transmit output node 3
	—			O6	Reserved
	—			O7	Reserved
A18	P14.15	I	SLOW / PU1 / VEXT / ES	General-purpose input	
	GTM_TIM6_IN7_3			Mux input channel 7 of TIM module 6	
	GTM_TIM5_IN6_5			Mux input channel 6 of TIM module 5	
	GTM_TIM3_IN6_9			Mux input channel 6 of TIM module 3	
	MSC2_INJ1			Injection signal from port	
	ASCLIN5_ARXD			Receive input	
	ASCLIN7_ARXA			Receive input	
	CAN23_RXDC			CAN receive input node 3	
	P14.15			O0	General-purpose output
	GTM_TOUT263			O1	GTM muxed output
	ASCLIN1_ATX			O2	Transmit output
	IOM_MON2_13			O3	Monitor input 2
	IOM_REF2_13				Reference input 2
	—				Reserved
	—			O4	Reserved
	—			O5	Reserved
	—			O6	Reserved
—	O7	Reserved			

## Pin Definition and Functions BGA516 Package Variant Pin Configuration

Table 2-9 Port 15 Functions

Ball	Symbol	Ctrl.	Buffer Type	Function
G25	P15.0	I	FAST / PU1 / VEXT / ES	General-purpose input
	GTM_TIM3_IN3_4			Mux input channel 3 of TIM module 3
	GTM_TIM2_IN3_4			Mux input channel 3 of TIM module 2
	P15.0	O0	General-purpose output	
	GTM_TOUT71	O1	GTM muxed output	
	ASCLIN1_ATX	O2	Transmit output	
	IOM_MON2_13		Monitor input 2	
	IOM_REF2_13		Reference input 2	
	QSPI0_SLSO13	O3	Master slave select output	
	—	O4	Reserved	
	CAN02_TXD	O5	CAN transmit output node 2	
	IOM_MON2_7		Monitor input 2	
	IOM_REF2_7		Reference input 2	
	ASCLIN1_ASCLK	O6	Shift clock output	
	—	O7	Reserved	
F23	P15.1	I	FAST / PU1 / VEXT / ES	General-purpose input
	GTM_TIM3_IN4_4			Mux input channel 4 of TIM module 3
	GTM_TIM2_IN4_4			Mux input channel 4 of TIM module 2
	CAN02_RXDA			CAN receive input node 2
	ASCLIN1_ARXA			Receive input
	QSPI2_SLSIB			Slave select input
	SCU_E_REQ7_2			ERU Channel 7 inputs 0 to 5 (0 is the LSB and 5 is the MSB)
	P15.1	O0	General-purpose output	
	GTM_TOUT72	O1	GTM muxed output	
	ASCLIN1_ATX	O2	Transmit output	
	IOM_MON2_13		Monitor input 2	
	IOM_REF2_13		Reference input 2	
	QSPI2_SLSO5	O3	Master slave select output	
	—	O4	Reserved	
	—	O5	Reserved	
—	O6	Reserved		
—	O7	Reserved		

## Pin Definition and Functions BGA516 Package Variant Pin Configuration

Table 2-9 Port 15 Functions (cont'd)

Ball	Symbol	Ctrl.	Buffer Type	Function
H24	P15.2	I	FAST / PU1 / VEXT / ES	General-purpose input
	GTM_TIM3_IN5_4			Mux input channel 5 of TIM module 3
	GTM_TIM2_IN5_4			Mux input channel 5 of TIM module 2
	QSPI2_SLSIA			Slave select input
	SENT_SENT10D			Receive input channel 10
	QSPI2_MRSTE			Master SPI data input
	P15.2			O0
	GTM_TOUT73	O1	GTM muxed output	
	ASCLIN0_ATX	O2	Transmit output	
	IOM_MON2_12		Monitor input 2	
	IOM_REF2_12		Reference input 2	
	QSPI2_SLSO0	O3	Master slave select output	
	—	O4	Reserved	
	CAN01_TXD	O5	CAN transmit output node 1	
	IOM_MON2_6	O6	Monitor input 2	
	IOM_REF2_6		Reference input 2	
	ASCLIN0_ASCLK		Shift clock output	
	—	O7	Reserved	
	G22	P15.3	I	FAST / PU1 / VEXT / ES
GTM_TIM3_IN6_4		Mux input channel 6 of TIM module 3		
GTM_TIM2_IN6_4		Mux input channel 6 of TIM module 2		
CAN01_RXDA		CAN receive input node 1		
ASCLIN0_ARXB		Receive input		
QSPI2_SCLKA		Slave SPI clock inputs		
P15.3		O0	General-purpose output	
GTM_TOUT74		O1	GTM muxed output	
ASCLIN0_ATX		O2	Transmit output	
IOM_MON2_12			Monitor input 2	
IOM_REF2_12			Reference input 2	
QSPI2_SCLK		O3	Master SPI clock output	
—		O4	Reserved	
MSC0_EN1		O5	Chip Select	
—		O6	Reserved	
—		O7	Reserved	

## Pin Definition and Functions BGA516 Package Variant Pin Configuration

Table 2-9 Port 15 Functions (cont'd)

Ball	Symbol	Ctrl.	Buffer Type	Function
F22	P15.4	I	FAST / PU1 / VEXT / ES	General-purpose input
	GTM_TIM3_IN7_4			Mux input channel 7 of TIM module 3
	GTM_TIM2_IN7_4			Mux input channel 7 of TIM module 2
	I2C0_SCLC			Serial Clock Input 2
	QSPI2_MRSTA			Master SPI data input
	SCU_E_REQ0_0			ERU Channel 0 inputs 0 to 5 (0 is the LSB and 5 is the MSB)
	SENT_SENT11D			Receive input channel 11
	P15.4			O0
	GTM_TOUT75	O1	GTM muxed output	
	ASCLIN1_ATX	O2	Transmit output	
	IOM_MON2_13		Monitor input 2	
	IOM_REF2_13		Reference input 2	
	QSPI2_MRST	O3	Slave SPI data output	
	IOM_MON2_2		Monitor input 2	
	IOM_REF2_2		Reference input 2	
	ASCLIN19_ATX	O4	Transmit output	
	—	O5	Reserved	
	I2C0_SCL	O6	Serial Clock Output	
	CCU60_CC62	O7	T12 PWM channel 62	
	IOM_MON1_0		Monitor input 1	
IOM_REF1_4	Reference input 1			

## Pin Definition and Functions BGA516 Package Variant Pin Configuration

Table 2-9 Port 15 Functions (cont'd)

Ball	Symbol	Ctrl.	Buffer Type	Function	
K19	P15.5	I	FAST / PU1 / VEXT / ES	General-purpose input	
	GTM_TIM3_IN0_4			Mux input channel 0 of TIM module 3	
	GTM_TIM2_IN0_4			Mux input channel 0 of TIM module 2	
	ASCLIN1_ARXB			Receive input	
	I2C0_SDAC			Serial Data Input 2	
	QSPI2_MTSRA			Slave SPI data input	
	SCU_E_REQ4_3			ERU Channel 4 inputs 0 to 5 (0 is the LSB and 5 is the MSB)	
	P15.5			O0	General-purpose output
	GTM_TOUT76			O1	GTM muxed output
	ASCLIN1_ATX			O2	Transmit output
	IOM_MON2_13			O2	Monitor input 2
	IOM_REF2_13				Reference input 2
	QSPI2_MTSR			O3	Master SPI data output
	—			O4	Reserved
	MSC0_EN0			O5	Chip Select
	I2C0_SDA			O6	Serial Data Output
F21	P15.6	I	FAST / PU1 / VEXT / ES	General-purpose input	
	GTM_TIM2_IN2_14			Mux input channel 2 of TIM module 2	
	GTM_TIM1_IN0_6			Mux input channel 0 of TIM module 1	
	GTM_TIM0_IN0_6			Mux input channel 0 of TIM module 0	
	QSPI2_MTSRB			Slave SPI data input	
	ASCLIN19_ARXA			Receive input	
	P15.6			O0	General-purpose output
	GTM_TOUT77			O1	GTM muxed output
	ASCLIN3_ATX			O2	Transmit output
	IOM_MON2_15			O2	Monitor input 2
IOM_REF2_15	Reference input 2				
QSPI2_MTSR	O3	Master SPI data output			
—	O4	Reserved			
QSPI2_SCLK	O5	Master SPI clock output			
ASCLIN3_ASCLK	O6	Shift clock output			
CCU60_CC60	O7	T12 PWM channel 60			
IOM_MON1_2	O7	Monitor input 1			
IOM_REF1_6		Reference input 1			

## Pin Definition and Functions BGA516 Package Variant Pin Configuration

Table 2-9 Port 15 Functions (cont'd)

Ball	Symbol	Ctrl.	Buffer Type	Function
J20	P15.7	I	FAST / PU1 / VEXT / ES	General-purpose input
	GTM_TIM1_IN1_5			Mux input channel 1 of TIM module 1
	GTM_TIM0_IN1_5			Mux input channel 1 of TIM module 0
	ASCLIN3_ARXA			Receive input
	QSPI2_MRSTB			Master SPI data input
	ASCLIN19_ARXB			Receive input
	P15.7	O0	General-purpose output	
	GTM_TOUT78	O1	GTM muxed output	
	ASCLIN3_ATX	O2	Transmit output	
	IOM_MON2_15		Monitor input 2	
	IOM_REF2_15		Reference input 2	
	QSPI2_MRST	O3	Slave SPI data output	
	IOM_MON2_2		Monitor input 2	
	IOM_REF2_2		Reference input 2	
	ASCLIN19_ATX	O4	Transmit output	
	—	O5	Reserved	
	—	O6	Reserved	
	CCU60_COUT60	O7	T12 PWM channel 60	
	IOM_MON1_3		Monitor input 1	
IOM_REF1_3	Reference input 1			
J19	P15.8	I	FAST / PU1 / VEXT / ES	General-purpose input
	GTM_TIM1_IN2_5			Mux input channel 2 of TIM module 1
	GTM_TIM0_IN2_5			Mux input channel 2 of TIM module 0
	QSPI2_SCLKB			Slave SPI clock inputs
	SCU_E_REQ5_0			ERU Channel 5 inputs 0 to 5 (0 is the LSB and 5 is the MSB)
	P15.8	O0	General-purpose output	
	GTM_TOUT79	O1	GTM muxed output	
	—	O2	Reserved	
	QSPI2_SCLK	O3	Master SPI clock output	
	—	O4	Reserved	
	—	O5	Reserved	
	ASCLIN3_ASCLK	O6	Shift clock output	
	CCU60_COUT61	O7	T12 PWM channel 61	
	IOM_MON1_4		Monitor input 1	
IOM_REF1_2	Reference input 1			

## Pin Definition and Functions BGA516 Package Variant Pin Configuration

Table 2-9 Port 15 Functions (cont'd)

Ball	Symbol	Ctrl.	Buffer Type	Function
B24	P15.10	I	FAST / PU1 / VEXT / ES6	General-purpose input
	GTM_TIM4_IN1_7			Mux input channel 1 of TIM module 4
	GTM_TIM2_IN1_8			Mux input channel 1 of TIM module 2
	P15.10	O0		General-purpose output
	GTM_TOUT242	O1		GTM muxed output
	—	O2		Reserved
	—	O3		Reserved
	—	O4		Reserved
	—	O5		Reserved
	—	O6		Reserved
—	O7	Reserved		
A24	P15.11	I	FAST / PU1 / VEXT / ES6	General-purpose input
	GTM_TIM4_IN2_6			Mux input channel 2 of TIM module 4
	GTM_TIM2_IN2_8			Mux input channel 2 of TIM module 2
	P15.11	O0		General-purpose output
	GTM_TOUT243	O1		GTM muxed output
	—	O2		Reserved
	—	O3		Reserved
	—	O4		Reserved
	—	O5		Reserved
	—	O6		Reserved
—	O7	Reserved		
B23	P15.12	I	FAST / PU1 / VEXT / ES6	General-purpose input
	GTM_TIM4_IN3_6			Mux input channel 3 of TIM module 4
	GTM_TIM2_IN3_6			Mux input channel 3 of TIM module 2
	P15.12	O0		General-purpose output
	GTM_TOUT244	O1		GTM muxed output
	—	O2		Reserved
	—	O3		Reserved
	—	O4		Reserved
	—	O5		Reserved
	—	O6		Reserved
—	O7	Reserved		

## Pin Definition and Functions BGA516 Package Variant Pin Configuration

Table 2-9 Port 15 Functions (cont'd)

Ball	Symbol	Ctrl.	Buffer Type	Function
A23	P15.13	I	FAST / PU1 / VEXT / ES6	General-purpose input
	GTM_TIM4_IN4_6			Mux input channel 4 of TIM module 4
	GTM_TIM2_IN4_9			Mux input channel 4 of TIM module 2
	P15.13	O0		General-purpose output
	GTM_TOUT245	O1		GTM muxed output
	—	O2		Reserved
	—	O3		Reserved
	—	O4		Reserved
	—	O5		Reserved
	—	O6		Reserved
—	O7	Reserved		
B22	P15.14	I	FAST / PU1 / VEXT / ES	General-purpose input
	GTM_TIM4_IN5_6			Mux input channel 5 of TIM module 4
	GTM_TIM2_IN5_12			Mux input channel 5 of TIM module 2
	P15.14	O0		General-purpose output
	GTM_TOUT246	O1		GTM muxed output
	—	O2		Reserved
	—	O3		Reserved
	—	O4		Reserved
	—	O5		Reserved
	—	O6		Reserved
—	O7	Reserved		
A22	P15.15	I	FAST / PU1 / VEXT / ES	General-purpose input
	GTM_TIM4_IN6_6			Mux input channel 6 of TIM module 4
	GTM_TIM2_IN6_9			Mux input channel 6 of TIM module 2
	P15.15	O0		General-purpose output
	GTM_TOUT247	O1		GTM muxed output
	—	O2		Reserved
	—	O3		Reserved
	—	O4		Reserved
	—	O5		Reserved
	—	O6		Reserved
—	O7	Reserved		

## Pin Definition and Functions BGA516 Package Variant Pin Configuration

Table 2-10 Port 20 Functions

Ball	Symbol	Ctrl.	Buffer Type	Function
N25	P20.0	I	FAST / PU1 / VEXT / ES	<b>General-purpose input</b>
	GTM_TIM1_IN6_7			<b>Mux input channel 6 of TIM module 1</b>
	GTM_TIM1_IN4_9			<b>Mux input channel 4 of TIM module 1</b>
	GTM_TIM0_IN6_7			<b>Mux input channel 6 of TIM module 0</b>
	CAN03_RXDC			<b>CAN receive input node 3</b>
	CCU_PAD_SYSCLK			<b>Sysclk input</b>
	CAN21_RXDC			<b>CAN receive input node 1</b>
	CBS_TGI0			<b>Trigger input</b>
	SCU_E_REQ6_0			<b>ERU Channel 6 inputs 0 to 5 (0 is the LSB and 5 is the MSB)</b>
	GPT120_T6EUDA			<b>Count direction control input of core timer T6</b>
	P20.0	O0	<b>General-purpose output</b>	
	GTM_TOUT59	O1	<b>GTM muxed output</b>	
	ASCLIN3_ATX	O2	<b>Transmit output</b>	
	IOM_MON2_15		<b>Monitor input 2</b>	
	IOM_REF2_15		<b>Reference input 2</b>	
	ASCLIN3_ASCLK	O3	<b>Shift clock output</b>	
	—	O4	<b>Reserved</b>	
	HSCT0_SYSCLK_OUT	O5	<b>sys clock output</b>	
	—	O6	<b>Reserved</b>	
	—	O7	<b>Reserved</b>	
CBS_TGO0	O	<b>Trigger output</b>		
M24	P20.1	I	SLOW / PU1 / VEXT / ES	<b>General-purpose input</b>
	GTM_TIM4_IN4_11			<b>Mux input channel 4 of TIM module 4</b>
	GTM_TIM3_IN3_5			<b>Mux input channel 3 of TIM module 3</b>
	GTM_TIM2_IN3_5			<b>Mux input channel 3 of TIM module 2</b>
	CBS_TGI1			<b>Trigger input</b>
	GTM_DTMA1_1			<b>CDTM1_DTM4</b>
	P20.1	O0	<b>General-purpose output</b>	
	GTM_TOUT60	O1	<b>GTM muxed output</b>	
	—	O2	<b>Reserved</b>	
	—	O3	<b>Reserved</b>	
	—	O4	<b>Reserved</b>	
	—	O5	<b>Reserved</b>	
	—	O6	<b>Reserved</b>	
	—	O7	<b>Reserved</b>	
	CBS_TGO1	O	<b>Trigger output</b>	

## Pin Definition and Functions BGA516 Package Variant Pin Configuration

Table 2-10 Port 20 Functions (cont'd)

Ball	Symbol	Ctrl.	Buffer Type	Function
N24	P20.2	I	S / PU / VEXT	<b>General-purpose input</b> This pin is latched at power on reset release to enter test mode.
	$\overline{\text{TESTMODE}}$			<b>Testmode Enable Input</b>
M25	P20.3	I	SLOW / PU1 / VEXT / ES	<b>General-purpose input</b>
	GTM_TIM4_IN5_11			<b>Mux input channel 5 of TIM module 4</b>
	GTM_TIM3_IN4_5			<b>Mux input channel 4 of TIM module 3</b>
	GTM_TIM2_IN4_5			<b>Mux input channel 4 of TIM module 2</b>
	ASCLIN3_ARXC			<b>Receive input</b>
	GPT120_T6INA			<b>Trigger/gate input of core timer T6</b>
	P20.3	O0		<b>General-purpose output</b>
	GTM_TOUT61	O1		<b>GTM muxed output</b>
	ASCLIN3_ATX	O2		<b>Transmit output</b>
	IOM_MON2_15			<b>Monitor input 2</b>
	IOM_REF2_15			<b>Reference input 2</b>
	QSPIO_SLSO9	O3		<b>Master slave select output</b>
	QSPI2_SLSO9	O4		<b>Master slave select output</b>
	CAN03_TXD	O5		<b>CAN transmit output node 3</b>
	IOM_MON2_8			<b>Monitor input 2</b>
	IOM_REF2_8			<b>Reference input 2</b>
	CAN21_TXD	O6		<b>CAN transmit output node 1</b>
—	O7	<b>Reserved</b>		
L22	P20.6	I	SLOW / PU1 / VEXT / ES	<b>General-purpose input</b>
	GTM_TIM6_IN0_1			<b>Mux input channel 0 of TIM module 6</b>
	GTM_TIM3_IN6_5			<b>Mux input channel 6 of TIM module 3</b>
	GTM_TIM2_IN6_5			<b>Mux input channel 6 of TIM module 2</b>
	CAN12_RXDA			<b>CAN receive input node 2</b>
	ASCLIN9_ARXE			<b>Receive input</b>
	P20.6	O0		<b>General-purpose output</b>
	GTM_TOUT62	O1		<b>GTM muxed output</b>
	ASCLIN1_ARTS	O2		<b>Ready to send output</b>
	QSPIO_SLSO8	O3		<b>Master slave select output</b>
	QSPI2_SLSO8	O4		<b>Master slave select output</b>
	—	O5		<b>Reserved</b>
	—	O6		<b>Reserved</b>
	—	O7		<b>Reserved</b>

## Pin Definition and Functions BGA516 Package Variant Pin Configuration

Table 2-10 Port 20 Functions (cont'd)

Ball	Symbol	Ctrl.	Buffer Type	Function
L24	P20.7	I	FAST / PU1 / VEXT / ES	General-purpose input
	GTM_TIM3_IN7_5			Mux input channel 7 of TIM module 3
	GTM_TIM2_IN7_5			Mux input channel 7 of TIM module 2
	GTM_TIM1_IN5_8			Mux input channel 5 of TIM module 1
	GTM_TIM6_IN1_1			Mux input channel 1 of TIM module 6
	CAN00_RXDB			CAN receive input node 0
	ASCLIN1_ACTSA			Clear to send input
	ASCLIN9_ARXF			Receive input
	P20.7			O0
	GTM_TOUT63	O1	GTM muxed output	
	ASCLIN9_ATX	O2	Transmit output	
	—	O3	Reserved	
	—	O4	Reserved	
	CAN12_TXD	O5	CAN transmit output node 2	
	—	O6	Reserved	
	CCU61_COUT63	O7	T13 PWM channel 63	
	IOM_MON1_7		Monitor input 1	
	IOM_REF1_7		Reference input 1	
L25	P20.8	I	FAST / PU1 / VEXT / ES	General-purpose input
	GTM_TIM6_IN2_1			Mux input channel 2 of TIM module 6
	GTM_TIM1_IN7_3			Mux input channel 7 of TIM module 1
	GTM_TIM0_IN7_3			Mux input channel 7 of TIM module 0
	P20.8	O0	General-purpose output	
	GTM_TOUT64	O1	GTM muxed output	
	ASCLIN1_ASLSO	O2	Slave select signal output	
	QSPI0_SLSO0	O3	Master slave select output	
	QSPI1_SLSO0	O4	Master slave select output	
	CAN00_TXD	O5	CAN transmit output node 0	
	IOM_MON2_5		Monitor input 2	
	IOM_REF2_5		Reference input 2	
	—	O6	Reserved	
	CCU61_CC60	O7	T12 PWM channel 60	
	IOM_MON1_8		Monitor input 1	
IOM_REF1_13		Reference input 1		

## Pin Definition and Functions BGA516 Package Variant Pin Configuration

Table 2-10 Port 20 Functions (cont'd)

Ball	Symbol	Ctrl.	Buffer Type	Function	
K22	P20.9	I	FAST / PU1 / VEXT / ES	General-purpose input	
	GTM_TIM6_IN3_1			Mux input channel 3 of TIM module 6	
	GTM_TIM3_IN5_5			Mux input channel 5 of TIM module 3	
	GTM_TIM2_IN5_5			Mux input channel 5 of TIM module 2	
	CAN03_RXDE			CAN receive input node 3	
	ASCLIN1_ARXC			Receive input	
	QSPIO_SLSIB			Slave select input	
	SCU_E_REQ7_0			ERU Channel 7 inputs 0 to 5 (0 is the LSB and 5 is the MSB)	
	P20.9			O0	General-purpose output
	GTM_TOUT65			O1	GTM muxed output
	—			O2	Reserved
	QSPIO_SLSO1			O3	Master slave select output
	QSPIO_SLSO1			O4	Master slave select output
	—			O5	Reserved
	—			O6	Reserved
	CCU61_CC61			O7	T12 PWM channel 61
	IOM_MON1_9				Monitor input 1
	IOM_REF1_12				Reference input 1
	K24			P20.10	I
GTM_TIM3_IN6_6		Mux input channel 6 of TIM module 3			
GTM_TIM2_IN6_6		Mux input channel 6 of TIM module 2			
P20.10		O0	General-purpose output		
GTM_TOUT66		O1	GTM muxed output		
ASCLIN1_ATX		O2	Transmit output		
IOM_MON2_13			Monitor input 2		
IOM_REF2_13			Reference input 2		
QSPIO_SLSO6		O3	Master slave select output		
QSPIO_SLSO7		O4	Master slave select output		
CAN03_TXD		O5	CAN transmit output node 3		
IOM_MON2_8			Monitor input 2		
IOM_REF2_8			Reference input 2		
ASCLIN1_ASCLK		O6	Shift clock output		
CCU61_CC62		O7	T12 PWM channel 62		
IOM_MON1_10			Monitor input 1		
IOM_REF1_11			Reference input 1		

## Pin Definition and Functions BGA516 Package Variant Pin Configuration

Table 2-10 Port 20 Functions (cont'd)

Ball	Symbol	Ctrl.	Buffer Type	Function
K25	P20.11	I	FAST / PU1 / VEXT / ES	General-purpose input
	GTM_TIM3_IN7_6			Mux input channel 7 of TIM module 3
	GTM_TIM2_IN7_6			Mux input channel 7 of TIM module 2
	QSPIO_SCLKA			Slave SPI clock inputs
	P20.11	O0		General-purpose output
	GTM_TOUT67	O1		GTM muxed output
	—	O2		Reserved
	QSPIO_SCLK	O3		Master SPI clock output
	—	O4		Reserved
	—	O5		Reserved
	—	O6		Reserved
	CCU61_COUT60	O7		T12 PWM channel 60
	IOM_MON1_11			Monitor input 1
	IOM_REF1_10			Reference input 1
J24	P20.12	I	FAST / PU1 / VEXT / ES	General-purpose input
	GTM_TIM3_IN0_5			Mux input channel 0 of TIM module 3
	GTM_TIM2_IN0_5			Mux input channel 0 of TIM module 2
	QSPIO_MRSTA			Master SPI data input
	IOM_PIN_13	GPIO pad input to FPC		
	P20.12	O0		General-purpose output
	GTM_TOUT68	O1		GTM muxed output
	IOM_MON0_13	O2		Monitor input 0
	—			Reserved
	QSPIO_MRST			Slave SPI data output
	IOM_MON2_0	O3		Monitor input 2
	IOM_REF2_0			Reference input 2
	QSPIO_MTSR			Master SPI data output
	—	O5		Reserved
	—	O6		Reserved
	CCU61_COUT61	O7		T12 PWM channel 61
	IOM_MON1_12	O7		Monitor input 1
IOM_REF1_9	Reference input 1			

## Pin Definition and Functions BGA516 Package Variant Pin Configuration

Table 2-10 Port 20 Functions (cont'd)

Ball	Symbol	Ctrl.	Buffer Type	Function
J25	P20.13	I	FAST / PU1 / VEXT / ES	General-purpose input
	GTM_TIM3_IN1_4			Mux input channel 1 of TIM module 3
	GTM_TIM2_IN1_4			Mux input channel 1 of TIM module 2
	QSPIO_SLSIA			Slave select input
	IOM_PIN_14			GPIO pad input to FPC
	P20.13	O0		General-purpose output
	GTM_TOUT69	O1		GTM muxed output
	IOM_MON0_14			Monitor input 0
	—	O2		Reserved
	QSPIO_SLSO2	O3		Master slave select output
	QSPIO_SLSO2	O4		Master slave select output
	QSPIO_SCLK	O5		Master SPI clock output
	—	O6		Reserved
	CCU61_COUT62	O7		T12 PWM channel 62
	IOM_MON1_13			Monitor input 1
IOM_REF1_8		Reference input 1		
H25	P20.14	I	FAST / PU1 / VEXT / ES	General-purpose input
	GTM_TIM3_IN2_4			Mux input channel 2 of TIM module 3
	GTM_TIM2_IN2_4			Mux input channel 2 of TIM module 2
	QSPIO_MTSRA			Slave SPI data input
	IOM_PIN_15			GPIO pad input to FPC
	P20.14	O0		General-purpose output
	GTM_TOUT70	O1		GTM muxed output
	IOM_MON0_15			Monitor input 0
	—	O2		Reserved
	QSPIO_MTSR	O3		Master SPI data output
	—	O4		Reserved
	—	O5		Reserved
	—	O6		Reserved
	—	O7		Reserved

## Pin Definition and Functions BGA516 Package Variant Pin Configuration

Table 2-11 Port 21 Functions

Ball	Symbol	Ctrl.	Buffer Type	Function
R22	P21.0	I	LVDS_R X/FAST/ PU1/ VEXT/ ES	General-purpose input
	GTM_TIM4_IN0_11			Mux input channel 0 of TIM module 4
	GTM_TIM3_IN4_6			Mux input channel 4 of TIM module 3
	GTM_TIM2_IN4_6			Mux input channel 4 of TIM module 2
	QSPI4_MRSTDN			Master SPI data input (LVDS N line)
	DMU_FDEST			Enter destructive debug mode
	ASCLIN11_ARXC			Receive input
	ASCLIN17_ARXB			Receive input
	P21.0	O0	General-purpose output	
	GTM_TOUT51	O1	GTM muxed output	
	ASCLIN11_ATX	O2	Transmit output	
	—	O3	Reserved	
	—	O4	Reserved	
	—	O5	Reserved	
	—	O6	Reserved	
	—	O7	Reserved	
HSM_HSM1	O	Pin Output Value		
P22	P21.1	I	LVDS_R X/FAST/ PU1/ VEXT/ ES	General-purpose input
	GTM_TIM4_IN1_13			Mux input channel 1 of TIM module 4
	GTM_TIM3_IN5_6			Mux input channel 5 of TIM module 3
	GTM_TIM2_IN5_6			Mux input channel 5 of TIM module 2
	QSPI4_MRSTDP			Master SPI data input (LVDS P line)
	ASCLIN11_ARXD			Receive input
	ASCLIN18_ARXA			Receive input
	GTM_DTMA4_1			CDTM4_DTM4
	P21.1	O0	General-purpose output	
	GTM_TOUT52	O1	GTM muxed output	
	—	O2	Reserved	
	—	O3	Reserved	
	—	O4	Reserved	
	—	O5	Reserved	
	—	O6	Reserved	
	—	O7	Reserved	
HSM_HSM2	O	Pin Output Value		

## Pin Definition and Functions BGA516 Package Variant Pin Configuration

Table 2-11 Port 21 Functions (cont'd)

Ball	Symbol	Ctrl.	Buffer Type	Function
R24	P21.2	I	LVDS_R X/FAST/ PU1/ VEXT/ ES	General-purpose input
	GTM_TIM5_IN4_11			Mux input channel 4 of TIM module 5
	GTM_TIM1_IN0_7			Mux input channel 0 of TIM module 1
	GTM_TIM0_IN0_7			Mux input channel 0 of TIM module 0
	QSPI2_MRSTCN			Master SPI data input (LVDS N line)
	SCU_EMGSTOP_POR T_B			Emergency stop Port Pin B input request
	ASCLIN3_ARXGN			Differential Receive input (low active)
	HSCT0_RXDN			Rx data
	QSPI4_MRSTCN			Master SPI data input (LVDS N line)
	ASCLIN11_ARXE			Receive input
	GTM_DTMA1_0			CDTM1_DTM4
	P21.2	O0		General-purpose output
	GTM_TOUT53	O1		GTM muxed output
	ASCLIN3_ASLSO	O2		Slave select signal output
	—	O3		Reserved
	—	O4		Reserved
	GETH_MDC	O5		MDIO clock
—	O6	Reserved		
—	O7	Reserved		
P24	P21.3	I	LVDS_R X/FAST/ PU1/ VEXT/ ES	General-purpose input
	GTM_TIM5_IN5_12			Mux input channel 5 of TIM module 5
	GTM_TIM1_IN1_6			Mux input channel 1 of TIM module 1
	GTM_TIM0_IN1_6			Mux input channel 1 of TIM module 0
	QSPI2_MRSTCP			Master SPI data input (LVDS P line)
	ASCLIN3_ARXGP			Differential Receive input (high active)
	GETH_MDIOD			MDIO Input
	HSCT0_RXDP			Rx data
	QSPI4_MRSTCP			Master SPI data input (LVDS P line)
	P21.3	O0		General-purpose output
	GTM_TOUT54	O1		GTM muxed output
	ASCLIN11_ASCLK	O2		Shift clock output
	ASCLIN18_ATX	O3		Transmit output
	—	O4		Reserved
	—	O5		Reserved
	—	O6		Reserved
	—	O7		Reserved
GETH_MDIO	O	MDIO Output		

## Pin Definition and Functions BGA516 Package Variant Pin Configuration

Table 2-11 Port 21 Functions (cont'd)

Ball	Symbol	Ctrl.	Buffer Type	Function
R25	P21.4	I	LVDS_TX / FAST / PU1 / VEXT / ES6	General-purpose input
	GTM_TIM5_IN6_12			Mux input channel 6 of TIM module 5
	GTM_TIM1_IN2_6			Mux input channel 2 of TIM module 1
	GTM_TIM0_IN2_6			Mux input channel 2 of TIM module 0
	ASCLIN18_ARXB			Receive input
	P21.4	O0		General-purpose output
	GTM_TOUT55	O1		GTM muxed output
	ASCLIN11_ASLSO	O2		Slave select signal output
	ASCLIN18_ATX	O3		Transmit output
	—	O4		Reserved
	—	O5		Reserved
	—	O6		Reserved
	—	O7		Reserved
	HSCT0_TXDN	O	Tx data	
P25	P21.5	I	LVDS_TX / FAST / PU1 / VEXT / ES6	General-purpose input
	GTM_TIM5_IN7_11			Mux input channel 7 of TIM module 5
	GTM_TIM1_IN3_6			Mux input channel 3 of TIM module 1
	GTM_TIM0_IN3_6			Mux input channel 3 of TIM module 0
	ASCLIN11_ARXF			Receive input
	P21.5	O0		General-purpose output
	GTM_TOUT56	O1		GTM muxed output
	ASCLIN3_ASCLK	O2		Shift clock output
	ASCLIN11_ATX	O3		Transmit output
	—	O4		Reserved
	—	O5		Reserved
	—	O6		Reserved
	—	O7		Reserved
	HSCT0_TXDP	O	Tx data	

## Pin Definition and Functions BGA516 Package Variant Pin Configuration

Table 2-11 Port 21 Functions (cont'd)

Ball	Symbol	Ctrl.	Buffer Type	Function
N22	P21.6/TDI	I	FAST / PD / PU2 / VEXT / ES3	<b>General-purpose input</b> PD during Reset and in DAP/DAPE or JTAG mode. After Reset release and when not in DAP/DAPE or JTAG mode: PU. In Standby mode: HighZ.
	GTM_TIM4_IN2_12			<b>Mux input channel 2 of TIM module 4</b>
	GTM_TIM1_IN4_8			<b>Mux input channel 4 of TIM module 1</b>
	GTM_TIM0_IN4_8			<b>Mux input channel 4 of TIM module 0</b>
	GPT120_T5EUDA			<b>Count direction control input of timer T5</b>
	ASCLIN3_ARXF			<b>Receive input</b>
	CBS_TGI2			<b>Trigger input</b>
	TDI			<b>JTAG Module Data Input</b>
	P21.6	O0	<b>General-purpose output</b>	
	GTM_TOUT57	O1	<b>GTM muxed output</b>	
	ASCLIN3_ASLSO	O2	<b>Slave select signal output</b>	
	—	O3	<b>Reserved</b>	
	—	O4	<b>Reserved</b>	
	—	O5	<b>Reserved</b>	
	—	O6	<b>Reserved</b>	
	GPT120_T3OUT	O7	<b>External output for overflow/underflow detection of core timer T3</b>	
	CBS_TGO2	O	<b>Trigger output</b>	
	DAP3	I/O	<b>DAP: DAP3 Data I/O</b>	

## Pin Definition and Functions BGA516 Package Variant Pin Configuration

Table 2-11 Port 21 Functions (cont'd)

Ball	Symbol	Ctrl.	Buffer Type	Function
N21	P21.7/TDO	I	FAST / PU2 / VEXT / ES4	General-purpose input
	GTM_TIM4_IN3_12			Mux input channel 3 of TIM module 4
	GTM_TIM1_IN5_7			Mux input channel 5 of TIM module 1
	GTM_TIM0_IN5_7			Mux input channel 5 of TIM module 0
	GPT120_T5INA			Trigger/gate input of timer T5
	CBS_TGI3			Trigger input
	GETH_RXERB			Receive Error MII
	P21.7	O0	General-purpose output	
	GTM_TOUT58	O1	GTM muxed output	
	ASCLIN3_ATX	O2	Transmit output	
	IOM_MON2_15		Monitor input 2	
	IOM_REF2_15		Reference input 2	
	ASCLIN3_ASCLK		O3	Shift clock output
	—	O4	Reserved	
	—	O5	Reserved	
	—	O6	Reserved	
	GPT120_T6OUT	O7	External output for overflow/underflow detection of core timer T6	
	CBS_TGO3	O	Trigger output	
	DAP2	I/O	DAP: DAP2 Data I/O	
	TDO	O	JTAG Module Data Output	

Table 2-12 Port 22 Functions

Ball	Symbol	Ctrl.	Buffer Type	Function
W25	P22.0	I	LVDS_TX / FAST / PU1 / VEXT / ES6	General-purpose input
	GTM_TIM1_IN1_7			Mux input channel 1 of TIM module 1
	GTM_TIM0_IN1_7			Mux input channel 1 of TIM module 0
	QSPI4_MTSRB			Slave SPI data input
	ASCLIN6_ARXE			Receive input
	P22.0	O0	General-purpose output	
	GTM_TOUT47	O1	GTM muxed output	
	ASCLIN3_ATXN	O2	Differential Transmit output (low active)	
	QSPI4_MTSR	O3	Master SPI data output	
	QSPI4_SCLKN	O4	Master SPI clock output (LVDS N line)	
	MSC1_FCLN	O5	Shift-clock inverted part of the differential signal	
	—	O6	Reserved	
	ASCLIN6_ATX	O7	Transmit output	

## Pin Definition and Functions BGA516 Package Variant Pin Configuration

Table 2-12 Port 22 Functions (cont'd)

Ball	Symbol	Ctrl.	Buffer Type	Function	
W24	P22.1	I	LVDS_TX / FAST / PU1 / VEXT / ES6	General-purpose input	
	GTM_TIM1_IN0_8			Mux input channel 0 of TIM module 1	
	GTM_TIM0_IN0_8			Mux input channel 0 of TIM module 0	
	QSPI4_MRSTB			Master SPI data input	
	ASCLIN7_ARXE			Receive input	
	P22.1			O0	General-purpose output
	GTM_TOUT48			O1	GTM muxed output
	ASCLIN3_ATXP			O2	Differential Transmit output (high active)
	QSPI4_MRST			O3	Slave SPI data output
	IOM_MON2_4				Monitor input 2
	IOM_REF2_4				Reference input 2
	QSPI4_SCLKP			O4	Master SPI clock output (LVDS P line)
	MSC1_FCLP			O5	Shift-clock direct part of the differential signal
	—			O6	Reserved
ASCLIN7_ATX	O7	Transmit output			
Y25	P22.2	I	LVDS_TX / FAST / PU1 / VEXT / ES6	General-purpose input	
	GTM_TIM1_IN3_7			Mux input channel 3 of TIM module 1	
	GTM_TIM0_IN3_7			Mux input channel 3 of TIM module 0	
	QSPI4_SLSIB			Slave select input	
	P22.2			O0	General-purpose output
	GTM_TOUT49			O1	GTM muxed output
	ASCLIN5_ATX			O2	Transmit output
	QSPI4_SLSO3			O3	Master slave select output
	QSPI4_MTSRN			O4	Master SPI data output (LVDS N line)
	MSC1_SON			O5	Data output - inverted part of the differential signal
	—			O6	Reserved
	—			O7	Reserved

## Pin Definition and Functions BGA516 Package Variant Pin Configuration

Table 2-12 Port 22 Functions (cont'd)

Ball	Symbol	Ctrl.	Buffer Type	Function
Y24	P22.3	I	LVDS_TX / FAST / PU1 / VEXT / ES6	General-purpose input
	GTM_TIM1_IN4_4			Mux input channel 4 of TIM module 1
	GTM_TIM0_IN4_4			Mux input channel 4 of TIM module 0
	QSPI4_SCLKB			Slave SPI clock inputs
	ASCLIN5_ARXC			Receive input
	P22.3	O0	General-purpose output	
	GTM_TOUT50	O1	GTM muxed output	
	—	O2	Reserved	
	QSPI4_SCLK	O3	Master SPI clock output	
	QSPI4_MTSRP	O4	Master SPI data output (LVDS P line)	
	MSC1_SOP	O5	Data output - direct part of the differential signal	
	—	O6	Reserved	
	—	O7	Reserved	
W21	P22.4	I	SLOW / PU1 / VEXT / ES	General-purpose input
	GTM_TIM3_IN0_8			Mux input channel 0 of TIM module 3
	ASCLIN7_ARXF			Receive input
	GTM_DTMA3_0			CDTM3_DTM4
	P22.4	O0	General-purpose output	
	GTM_TOUT130	O1	GTM muxed output	
	ASCLIN4_ASLSO	O2	Slave select signal output	
	—	O3	Reserved	
	QSPI0_SLSO12	O4	Master slave select output	
	—	O5	Reserved	
	CAN13_TXD	O6	CAN transmit output node 3	
	—	O7	Reserved	
	W22	P22.5	I	SLOW / PU1 / VEXT / ES
GTM_TIM3_IN1_7		Mux input channel 1 of TIM module 3		
QSPI0_MTSRC		Slave SPI data input		
CAN13_RXDC		CAN receive input node 3		
P22.5		O0	General-purpose output	
GTM_TOUT131		O1	GTM muxed output	
ASCLIN4_ATX		O2	Transmit output	
—		O3	Reserved	
QSPI0_MTSR		O4	Master SPI data output	
—		O5	Reserved	
—		O6	Reserved	
—		O7	Reserved	

## Pin Definition and Functions BGA516 Package Variant Pin Configuration

Table 2-12 Port 22 Functions (cont'd)

Ball	Symbol	Ctrl.	Buffer Type	Function	
V21	P22.6	I	SLOW / PU1 / VEXT / ES	General-purpose input	
	GTM_TIM3_IN2_6			Mux input channel 2 of TIM module 3	
	GTM_TIM2_IN6_14			Mux input channel 6 of TIM module 2	
	QSPIO_MRSTC			Master SPI data input	
	ASCLIN4_ARXC			Receive input	
	P22.6			O0	General-purpose output
	GTM_TOUT132			O1	GTM muxed output
	—			O2	Reserved
	—			O3	Reserved
	QSPIO_MRST			O4	Slave SPI data output
	IOM_MON2_0	Monitor input 2			
	IOM_REF2_0	Reference input 2			
	CAN21_TXD	O5	CAN transmit output node 1		
	—	O6	Reserved		
—	O7	Reserved			
V22	P22.7	I	SLOW / PU1 / VEXT / ES	General-purpose input	
	GTM_TIM3_IN3_7			Mux input channel 3 of TIM module 3	
	QSPIO_SCLKC			Slave SPI clock inputs	
	CAN21_RXDF			CAN receive input node 1	
	P22.7	O0	General-purpose output		
	GTM_TOUT133	O1	GTM muxed output		
	ASCLIN4_ASCLK	O2	Shift clock output		
	ASCLIN17_ATX	O3	Transmit output		
	QSPIO_SCLK	O4	Master SPI clock output		
	—	O5	Reserved		
	—	O6	Reserved		
	—	O7	Reserved		

## Pin Definition and Functions BGA516 Package Variant Pin Configuration

Table 2-12 Port 22 Functions (cont'd)

Ball	Symbol	Ctrl.	Buffer Type	Function
U21	P22.8	I	SLOW / PU1 / VEXT / ES	General-purpose input
	GTM_TIM5_IN0_4			Mux input channel 0 of TIM module 5
	GTM_TIM3_IN4_7			Mux input channel 4 of TIM module 3
	QSPI0_SCLKB			Slave SPI clock inputs
	P22.8	O0		General-purpose output
	GTM_TOUT134	O1		GTM muxed output
	ASCLIN5_ASCLK	O2		Shift clock output
	—	O3		Reserved
	QSPI0_SCLK	O4		Master SPI clock output
	CAN22_TXD	O5		CAN transmit output node 2
	—	O6		Reserved
	—	O7		Reserved
U22	P22.9	I	SLOW / PU1 / VEXT / ES	General-purpose input
	GTM_TIM5_IN1_10			Mux input channel 1 of TIM module 5
	GTM_TIM3_IN5_7			Mux input channel 5 of TIM module 3
	QSPI0_MRSTB			Master SPI data input
	ASCLIN4_ARXD			Receive input
	CAN22_RXDE			CAN receive input node 2
	GTM_DTMA3_1			CDTM3_DTM4
	P22.9	O0		General-purpose output
	GTM_TOUT135	O1		GTM muxed output
	—	O2		Reserved
	—	O3		Reserved
	QSPI0_MRST	O4		Slave SPI data output
	IOM_MON2_0			Monitor input 2
	IOM_REF2_0			Reference input 2
	—			O5
	—	O6		Reserved
	—	O7		Reserved

## Pin Definition and Functions BGA516 Package Variant Pin Configuration

Table 2-12 Port 22 Functions (cont'd)

Ball	Symbol	Ctrl.	Buffer Type	Function
T21	P22.10	I	SLOW / PU1 / VEXT / ES	General-purpose input
	GTM_TIM5_IN2_8			Mux input channel 2 of TIM module 5
	GTM_TIM3_IN6_7			Mux input channel 6 of TIM module 3
	QSPIO_MTSRB			Slave SPI data input
	P22.10	O0		General-purpose output
	GTM_TOUT136	O1		GTM muxed output
	ASCLIN4_ATX	O2		Transmit output
	—	O3		Reserved
	QSPIO_MTSR	O4		Master SPI data output
	CAN23_TXD	O5		CAN transmit output node 3
	—	O6		Reserved
	—	O7		Reserved
T22	P22.11	I	SLOW / PU1 / VEXT / ES	General-purpose input
	GTM_TIM5_IN3_10			Mux input channel 3 of TIM module 5
	GTM_TIM3_IN7_7			Mux input channel 7 of TIM module 3
	CAN23_RXDE			CAN receive input node 3
	ASCLIN17_ARXA			Receive input
	P22.11	O0		General-purpose output
	GTM_TOUT137	O1		GTM muxed output
	ASCLIN4_ASLSO	O2		Slave select signal output
	ASCLIN17_ATX	O3		Transmit output
	QSPIO_SLSO10	O4		Master slave select output
	—	O5		Reserved
	—	O6		Reserved
—	O7	Reserved		

## Pin Definition and Functions BGA516 Package Variant Pin Configuration

Table 2-13 Port 23 Functions

Ball	Symbol	Ctrl.	Buffer Type	Function
AC25	P23.0	I	SLOW / PU1 / VEXT / ES	<b>General-purpose input</b>
	GTM_TIM6_IN7_1			<b>Mux input channel 7 of TIM module 6</b>
	GTM_TIM1_IN5_4			<b>Mux input channel 5 of TIM module 1</b>
	GTM_TIM0_IN5_4			<b>Mux input channel 5 of TIM module 0</b>
	CAN10_RXDC			<b>CAN receive input node 0</b>
	P23.0	O0		<b>General-purpose output</b>
	GTM_TOUT41	O1		<b>GTM muxed output</b>
	—	O2		<b>Reserved</b>
	—	O3		<b>Reserved</b>
	—	O4		<b>Reserved</b>
	—	O5		<b>Reserved</b>
	—	O6		<b>Reserved</b>
	—	O7		<b>Reserved</b>
AB24	P23.1	I	FAST / PU1 / VEXT / ES	<b>General-purpose input</b>
	GTM_TIM6_IN6_1			<b>Mux input channel 6 of TIM module 6</b>
	GTM_TIM1_IN6_4			<b>Mux input channel 6 of TIM module 1</b>
	GTM_TIM0_IN6_4			<b>Mux input channel 6 of TIM module 0</b>
	MSC1_SDIO			<b>Upstream asynchronous input signal</b>
	ASCLIN6_ARXF			<b>Receive input</b>
	P23.1	O0		<b>General-purpose output</b>
	GTM_TOUT42	O1		<b>GTM muxed output</b>
	ASCLIN1_ARTS	O2		<b>Ready to send output</b>
	QSPI4_SLSO6	O3		<b>Master slave select output</b>
	GTM_CLK0	O4		<b>CGM generated clock</b>
	CAN10_TXD	O5		<b>CAN transmit output node 0</b>
	CCU_EXTCLK0	O6		<b>External Clock 0</b>
ASCLIN6_ASCLK	O7	<b>Shift clock output</b>		

## Pin Definition and Functions BGA516 Package Variant Pin Configuration

Table 2-13 Port 23 Functions (cont'd)

Ball	Symbol	Ctrl.	Buffer Type	Function	
AB25	P23.2	I	SLOW / PU1 / VEXT / ES	General-purpose input	
	GTM_TIM6_IN5_1			Mux input channel 5 of TIM module 6	
	GTM_TIM1_IN6_5			Mux input channel 6 of TIM module 1	
	GTM_TIM0_IN6_5			Mux input channel 6 of TIM module 0	
	ASCLIN7_ARXC			Receive input	
	P23.2			O0	General-purpose output
	GTM_TOUT43			O1	GTM muxed output
	—			O2	Reserved
	—			O3	Reserved
	CAN23_TXD			O4	CAN transmit output node 3
	CAN12_TXD	O5	CAN transmit output node 2		
	—	O6	Reserved		
	—	O7	Reserved		
	AA24	P23.3	I	SLOW / PU1 / VEXT / ES	General-purpose input
GTM_TIM6_IN4_2		Mux input channel 4 of TIM module 6			
GTM_TIM1_IN7_4		Mux input channel 7 of TIM module 1			
GTM_TIM0_IN7_4		Mux input channel 7 of TIM module 0			
MSC1_INJ0		Injection signal from port			
ASCLIN6_ARXA		Receive input			
CAN12_RXDC		CAN receive input node 2			
CAN23_RXDB		CAN receive input node 3			
P23.3		O0			General-purpose output
GTM_TOUT44		O1			GTM muxed output
ASCLIN7_ATX		O2	Transmit output		
—		O3	Reserved		
—		O4	Reserved		
—		O5	Reserved		
—		O6	Reserved		
—		O7	Reserved		

## Pin Definition and Functions BGA516 Package Variant Pin Configuration

Table 2-13 Port 23 Functions (cont'd)

Ball	Symbol	Ctrl.	Buffer Type	Function
AA25	P23.4	I	FAST / PU1 / VEXT / ES	General-purpose input
	GTM_TIM6_IN3_2			Mux input channel 3 of TIM module 6
	GTM_TIM1_IN7_5			Mux input channel 7 of TIM module 1
	GTM_TIM0_IN7_5			Mux input channel 7 of TIM module 0
	P23.4	O0		General-purpose output
	GTM_TOUT45	O1		GTM muxed output
	ASCLIN6_ASLSO	O2		Slave select signal output
	QSPI4_SLSO5	O3		Master slave select output
	—	O4		Reserved
	MSC1_EN0	O5		Chip Select
	—	O6		Reserved
—	O7	Reserved		
AA22	P23.5	I	FAST / PU1 / VEXT / ES	General-purpose input
	GTM_TIM6_IN2_2			Mux input channel 2 of TIM module 6
	GTM_TIM1_IN2_7			Mux input channel 2 of TIM module 1
	GTM_TIM0_IN2_7			Mux input channel 2 of TIM module 0
	ASCLIN16_ARXA			Receive input
	P23.5	O0		General-purpose output
	GTM_TOUT46	O1		GTM muxed output
	ASCLIN6_ATX	O2		Transmit output
	QSPI4_SLSO4	O3		Master slave select output
	—	O4		Reserved
	MSC1_EN1	O5		Chip Select
CAN22_TXD	O6	CAN transmit output node 2		
—	O7	Reserved		
Y22	P23.6	I	SLOW / PU1 / VEXT / ES	General-purpose input
	GTM_TIM6_IN1_2			Mux input channel 1 of TIM module 6
	GTM_TIM4_IN2_7			Mux input channel 2 of TIM module 4
	GTM_TIM1_IN2_10			Mux input channel 2 of TIM module 1
	CAN22_RXDC			CAN receive input node 2
	P23.6	O0		General-purpose output
	GTM_TOUT138	O1		GTM muxed output
	ASCLIN16_ATX	O2		Transmit output
	—	O3		Reserved
	QSPI0_SLSO11	O4		Master slave select output
	CAN11_TXD	O5		CAN transmit output node 1
—	O6	Reserved		
—	O7	Reserved		

## Pin Definition and Functions BGA516 Package Variant Pin Configuration

Table 2-13 Port 23 Functions (cont'd)

Ball	Symbol	Ctrl.	Buffer Type	Function
Y21	P23.7	I	SLOW / PU1 / VEXT / ES	General-purpose input
	GTM_TIM6_IN0_2			Mux input channel 0 of TIM module 6
	GTM_TIM4_IN3_7			Mux input channel 3 of TIM module 4
	GTM_TIM1_IN3_10			Mux input channel 3 of TIM module 1
	CAN11_RXDC			CAN receive input node 1
	ASCLIN16_ARXB			Receive input
	P23.7	O0		General-purpose output
	GTM_TOUT139	O1		GTM muxed output
	ASCLIN16_ATX	O2		Transmit output
	—	O3		Reserved
	—	O4		Reserved
	—	O5		Reserved
	—	O6		Reserved
	—	O7		Reserved

Table 2-14 Port 24 Functions

Ball	Symbol	Ctrl.	Buffer Type	Function
U29	P24.0	I	FAST / PU1 / VEXT / ES	General-purpose input
	GTM_TIM6_IN0_6			Mux input channel 0 of TIM module 6
	GTM_TIM4_IN0_8			Mux input channel 0 of TIM module 4
	P24.0	O0		General-purpose output
	GTM_TOUT222	O1		GTM muxed output
	—	O2		Reserved
	—	O3		Reserved
	—	O4		Reserved
	—	O5		Reserved
	—	O6		Reserved
	—	O7		Reserved

## Pin Definition and Functions BGA516 Package Variant Pin Configuration

Table 2-14 Port 24 Functions (cont'd)

Ball	Symbol	Ctrl.	Buffer Type	Function
U30	P24.1	I	FAST / PU1 / VEXT / ES	General-purpose input
	GTM_TIM6_IN1_6			Mux input channel 1 of TIM module 6
	GTM_TIM4_IN1_8			Mux input channel 1 of TIM module 4
	P24.1	O0		General-purpose output
	GTM_TOUT223	O1		GTM muxed output
	—	O2		Reserved
	—	O3		Reserved
	—	O4		Reserved
	—	O5		Reserved
	—	O6		Reserved
—	O7	Reserved		
T29	P24.2	I	FAST / PU1 / VEXT / ES	General-purpose input
	GTM_TIM6_IN2_6			Mux input channel 2 of TIM module 6
	GTM_TIM4_IN2_8			Mux input channel 2 of TIM module 4
	P24.2	O0		General-purpose output
	GTM_TOUT224	O1		GTM muxed output
	—	O2		Reserved
	—	O3		Reserved
	—	O4		Reserved
	—	O5		Reserved
	—	O6		Reserved
—	O7	Reserved		
T30	P24.3	I	FAST / PU1 / VEXT / ES	General-purpose input
	GTM_TIM6_IN3_6			Mux input channel 3 of TIM module 6
	GTM_TIM4_IN3_8			Mux input channel 3 of TIM module 4
	P24.3	O0		General-purpose output
	GTM_TOUT225	O1		GTM muxed output
	—	O2		Reserved
	—	O3		Reserved
	—	O4		Reserved
	—	O5		Reserved
	—	O6		Reserved
—	O7	Reserved		

## Pin Definition and Functions BGA516 Package Variant Pin Configuration

Table 2-14 Port 24 Functions (cont'd)

Ball	Symbol	Ctrl.	Buffer Type	Function
R29	P24.4	I	FAST / PU1 / VEXT / ES	General-purpose input
	GTM_TIM6_IN4_5			Mux input channel 4 of TIM module 6
	GTM_TIM4_IN4_7			Mux input channel 4 of TIM module 4
	P24.4	O0		General-purpose output
	GTM_TOUT226	O1		GTM muxed output
	—	O2		Reserved
	—	O3		Reserved
	—	O4		Reserved
	—	O5		Reserved
	—	O6		Reserved
—	O7	Reserved		
R30	P24.5	I	FAST / PU1 / VEXT / ES	General-purpose input
	GTM_TIM6_IN5_5			Mux input channel 5 of TIM module 6
	GTM_TIM4_IN5_7			Mux input channel 5 of TIM module 4
	P24.5	O0		General-purpose output
	GTM_TOUT227	O1		GTM muxed output
	—	O2		Reserved
	—	O3		Reserved
	—	O4		Reserved
	—	O5		Reserved
	—	O6		Reserved
—	O7	Reserved		
P29	P24.6	I	FAST / PU1 / VEXT / ES	General-purpose input
	GTM_TIM6_IN6_5			Mux input channel 6 of TIM module 6
	GTM_TIM4_IN6_7			Mux input channel 6 of TIM module 4
	P24.6	O0		General-purpose output
	GTM_TOUT228	O1		GTM muxed output
	—	O2		Reserved
	—	O3		Reserved
	—	O4		Reserved
	—	O5		Reserved
	—	O6		Reserved
—	O7	Reserved		

## Pin Definition and Functions BGA516 Package Variant Pin Configuration

Table 2-14 Port 24 Functions (cont'd)

Ball	Symbol	Ctrl.	Buffer Type	Function
P30	P24.7	I	FAST / PU1 / VEXT / ES	General-purpose input
	GTM_TIM6_IN7_5			Mux input channel 7 of TIM module 6
	GTM_TIM4_IN7_7			Mux input channel 7 of TIM module 4
	P24.7	O0		General-purpose output
	GTM_TOUT229	O1		GTM muxed output
	—	O2		Reserved
	—	O3		Reserved
	—	O4		Reserved
	—	O5		Reserved
	—	O6		Reserved
—	O7	Reserved		
N29	P24.8	I	FAST / PU1 / VEXT / ES	General-purpose input
	GTM_TIM5_IN0_5			Mux input channel 0 of TIM module 5
	P24.8			O0
	GTM_TOUT230	O1		GTM muxed output
	—	O2		Reserved
	—	O3		Reserved
	—	O4		Reserved
	—	O5		Reserved
	—	O6		Reserved
	—	O7		Reserved
N30	P24.9	I	FAST / PU1 / VEXT / ES	General-purpose input
	GTM_TIM5_IN1_6			Mux input channel 1 of TIM module 5
	P24.9			O0
	GTM_TOUT231	O1		GTM muxed output
	—	O2		Reserved
	—	O3		Reserved
	—	O4		Reserved
	—	O5		Reserved
	—	O6		Reserved
	—	O7		Reserved

## Pin Definition and Functions BGA516 Package Variant Pin Configuration

Table 2-14 Port 24 Functions (cont'd)

Ball	Symbol	Ctrl.	Buffer Type	Function
M29	P24.10	I	FAST / PU1 / VEXT / ES	General-purpose input
	GTM_TIM5_IN2_5			Mux input channel 2 of TIM module 5
	P24.10	O0		General-purpose output
	GTM_TOUT232	O1		GTM muxed output
	—	O2		Reserved
	—	O3		Reserved
	—	O4		Reserved
	—	O5		Reserved
	—	O6		Reserved
	—	O7		Reserved
M30	P24.11	I	FAST / PU1 / VEXT / ES	General-purpose input
	GTM_TIM5_IN3_6			Mux input channel 3 of TIM module 5
	P24.11	O0		General-purpose output
	GTM_TOUT233	O1		GTM muxed output
	—	O2		Reserved
	—	O3		Reserved
	—	O4		Reserved
	—	O5		Reserved
	—	O6		Reserved
	—	O7		Reserved
L29	P24.12	I	FAST / PU1 / VEXT / ES	General-purpose input
	GTM_TIM5_IN4_6			Mux input channel 4 of TIM module 5
	P24.12	O0		General-purpose output
	GTM_TOUT234	O1		GTM muxed output
	—	O2		Reserved
	—	O3		Reserved
	—	O4		Reserved
	—	O5		Reserved
	—	O6		Reserved
	—	O7		Reserved

## Pin Definition and Functions BGA516 Package Variant Pin Configuration

Table 2-14 Port 24 Functions (cont'd)

Ball	Symbol	Ctrl.	Buffer Type	Function
L30	P24.13	I	FAST / PU1 / VEXT / ES	General-purpose input
	GTM_TIM5_IN5_6			Mux input channel 5 of TIM module 5
	P24.13	O0		General-purpose output
	GTM_TOUT235	O1		GTM muxed output
	—	O2		Reserved
	—	O3		Reserved
	—	O4		Reserved
	—	O5		Reserved
	—	O6		Reserved
	—	O7		Reserved
K29	P24.14	I	FAST / PU1 / VEXT / ES	General-purpose input
	GTM_TIM5_IN6_6			Mux input channel 6 of TIM module 5
	P24.14	O0		General-purpose output
	GTM_TOUT236	O1		GTM muxed output
	—	O2		Reserved
	—	O3		Reserved
	—	O4		Reserved
	—	O5		Reserved
	—	O6		Reserved
	—	O7		Reserved
K30	P24.15	I	FAST / PU1 / VEXT / ES	General-purpose input
	GTM_TIM5_IN7_5			Mux input channel 7 of TIM module 5
	P24.15	O0		General-purpose output
	GTM_TOUT237	O1		GTM muxed output
	—	O2		Reserved
	—	O3		Reserved
	—	O4		Reserved
	—	O5		Reserved
	—	O6		Reserved
	—	O7		Reserved

## Pin Definition and Functions BGA516 Package Variant Pin Configuration

Table 2-15 Port 25 Functions

Ball	Symbol	Ctrl.	Buffer Type	Function
AG30	P25.0	I	FAST / PU1 / VEXT / ES	General-purpose input
	GTM_TIM6_IN0_7			Mux input channel 0 of TIM module 6
	GTM_TIM3_IN0_12			Mux input channel 0 of TIM module 3
	P25.0	O0		General-purpose output
	GTM_TOUT206	O1		GTM muxed output
	—	O2		Reserved
	—	O3		Reserved
	—	O4		Reserved
	—	O5		Reserved
	—	O6		Reserved
—	O7	Reserved		
AF30	P25.1	I	FAST / PU1 / VEXT / ES	General-purpose input
	GTM_TIM6_IN1_7			Mux input channel 1 of TIM module 6
	GTM_TIM3_IN1_11			Mux input channel 1 of TIM module 3
	P25.1	O0		General-purpose output
	GTM_TOUT207	O1		GTM muxed output
	—	O2		Reserved
	—	O3		Reserved
	—	O4		Reserved
	—	O5		Reserved
	—	O6		Reserved
—	O7	Reserved		
AF29	P25.2	I	FAST / PU1 / VEXT / ES	General-purpose input
	GTM_TIM6_IN2_7			Mux input channel 2 of TIM module 6
	GTM_TIM3_IN2_9			Mux input channel 2 of TIM module 3
	P25.2	O0		General-purpose output
	GTM_TOUT208	O1		GTM muxed output
	—	O2		Reserved
	—	O3		Reserved
	—	O4		Reserved
	—	O5		Reserved
	—	O6		Reserved
—	O7	Reserved		

## Pin Definition and Functions BGA516 Package Variant Pin Configuration

Table 2-15 Port 25 Functions (cont'd)

Ball	Symbol	Ctrl.	Buffer Type	Function
AE30	P25.3	I	FAST / PU1 / VEXT / ES	General-purpose input
	GTM_TIM6_IN3_7			Mux input channel 3 of TIM module 6
	GTM_TIM3_IN3_9			Mux input channel 3 of TIM module 3
	P25.3	O0		General-purpose output
	GTM_TOUT209	O1		GTM muxed output
	—	O2		Reserved
	—	O3		Reserved
	—	O4		Reserved
	—	O5		Reserved
	—	O6		Reserved
—	O7	Reserved		
AE29	P25.4	I	FAST / PU1 / VEXT / ES	General-purpose input
	GTM_TIM6_IN4_6			Mux input channel 4 of TIM module 6
	GTM_TIM3_IN4_10			Mux input channel 4 of TIM module 3
	P25.4	O0		General-purpose output
	GTM_TOUT210	O1		GTM muxed output
	—	O2		Reserved
	—	O3		Reserved
	—	O4		Reserved
	—	O5		Reserved
	—	O6		Reserved
—	O7	Reserved		
AD30	P25.5	I	FAST / PU1 / VEXT / ES	General-purpose input
	GTM_TIM6_IN5_6			Mux input channel 5 of TIM module 6
	GTM_TIM3_IN5_11			Mux input channel 5 of TIM module 3
	P25.5	O0		General-purpose output
	GTM_TOUT211	O1		GTM muxed output
	—	O2		Reserved
	—	O3		Reserved
	—	O4		Reserved
	—	O5		Reserved
	—	O6		Reserved
—	O7	Reserved		

## Pin Definition and Functions BGA516 Package Variant Pin Configuration

Table 2-15 Port 25 Functions (cont'd)

Ball	Symbol	Ctrl.	Buffer Type	Function
W29	P25.6	I	FAST / PU1 / VEXT / ES	General-purpose input
	GTM_TIM6_IN6_6			Mux input channel 6 of TIM module 6
	GTM_TIM3_IN6_14			Mux input channel 6 of TIM module 3
	P25.6	O0		General-purpose output
	GTM_TOUT212	O1		GTM muxed output
	—	O2		Reserved
	—	O3		Reserved
	—	O4		Reserved
	—	O5		Reserved
	—	O6		Reserved
—	O7	Reserved		
AD29	P25.7	I	FAST / PU1 / VEXT / ES	General-purpose input
	GTM_TIM6_IN7_6			Mux input channel 7 of TIM module 6
	GTM_TIM3_IN7_10			Mux input channel 7 of TIM module 3
	P25.7	O0		General-purpose output
	GTM_TOUT213	O1		GTM muxed output
	—	O2		Reserved
	—	O3		Reserved
	—	O4		Reserved
	—	O5		Reserved
	—	O6		Reserved
—	O7	Reserved		
AC29	P25.8	I	FAST / PU1 / VEXT / ES	General-purpose input
	GTM_TIM4_IN0_9			Mux input channel 0 of TIM module 4
	P25.8			O0
	GTM_TOUT214	O1		GTM muxed output
	—	O2		Reserved
	—	O3		Reserved
	—	O4		Reserved
	—	O5		Reserved
	—	O6		Reserved
	—	O7		Reserved

## Pin Definition and Functions BGA516 Package Variant Pin Configuration

Table 2-15 Port 25 Functions (cont'd)

Ball	Symbol	Ctrl.	Buffer Type	Function
AC30	P25.9	I	FAST / PU1 / VEXT / ES	General-purpose input
	GTM_TIM4_IN1_9			Mux input channel 1 of TIM module 4
	P25.9	O0		General-purpose output
	GTM_TOUT215	O1		GTM muxed output
	—	O2		Reserved
	—	O3		Reserved
	—	O4		Reserved
	—	O5		Reserved
	—	O6		Reserved
	—	O7		Reserved
AB29	P25.10	I	FAST / PU1 / VEXT / ES	General-purpose input
	GTM_TIM4_IN2_9			Mux input channel 2 of TIM module 4
	P25.10	O0		General-purpose output
	GTM_TOUT216	O1		GTM muxed output
	—	O2		Reserved
	—	O3		Reserved
	—	O4		Reserved
	—	O5		Reserved
	—	O6		Reserved
	—	O7		Reserved
AB30	P25.11	I	FAST / PU1 / VEXT / ES	General-purpose input
	GTM_TIM4_IN3_9			Mux input channel 3 of TIM module 4
	P25.11	O0		General-purpose output
	GTM_TOUT217	O1		GTM muxed output
	—	O2		Reserved
	—	O3		Reserved
	—	O4		Reserved
	—	O5		Reserved
	—	O6		Reserved
	—	O7		Reserved

## Pin Definition and Functions BGA516 Package Variant Pin Configuration

Table 2-15 Port 25 Functions (cont'd)

Ball	Symbol	Ctrl.	Buffer Type	Function
AA29	P25.12	I	FAST / PU1 / VEXT / ES	General-purpose input
	GTM_TIM4_IN4_8			Mux input channel 4 of TIM module 4
	P25.12	O0		General-purpose output
	GTM_TOUT218	O1		GTM muxed output
	—	O2		Reserved
	—	O3		Reserved
	—	O4		Reserved
	—	O5		Reserved
	—	O6		Reserved
	—	O7		Reserved
AA30	P25.13	I	FAST / PU1 / VEXT / ES	General-purpose input
	GTM_TIM4_IN5_8			Mux input channel 5 of TIM module 4
	P25.13	O0		General-purpose output
	GTM_TOUT219	O1		GTM muxed output
	—	O2		Reserved
	—	O3		Reserved
	—	O4		Reserved
	—	O5		Reserved
	—	O6		Reserved
	—	O7		Reserved
Y29	P25.14	I	FAST / PU1 / VEXT / ES	General-purpose input
	GTM_TIM4_IN6_8			Mux input channel 6 of TIM module 4
	P25.14	O0		General-purpose output
	GTM_TOUT220	O1		GTM muxed output
	—	O2		Reserved
	—	O3		Reserved
	—	O4		Reserved
	—	O5		Reserved
	—	O6		Reserved
	—	O7		Reserved

## Pin Definition and Functions BGA516 Package Variant Pin Configuration

Table 2-15 Port 25 Functions (cont'd)

Ball	Symbol	Ctrl.	Buffer Type	Function
Y30	P25.15	I	FAST / PU1 / VEXT / ES	General-purpose input
	GTM_TIM4_IN7_8			Mux input channel 7 of TIM module 4
	P25.15	O0		General-purpose output
	GTM_TOUT221	O1		GTM muxed output
	—	O2		Reserved
	—	O3		Reserved
	—	O4		Reserved
	—	O5		Reserved
	—	O6		Reserved
	—	O7		Reserved

Table 2-16 Port 26 Functions

Ball	Symbol	Ctrl.	Buffer Type	Function
AG29	P26.0	I	SLOW / PU1 / VEXT / ES	General-purpose input
	GTM_TIM6_IN6_9			Mux input channel 6 of TIM module 6
	GTM_TIM3_IN6_11			Mux input channel 6 of TIM module 3
	P26.0	O0		General-purpose output
	GTM_TOUT212	O1		GTM muxed output
	—	O2		Reserved
	—	O3		Reserved
	—	O4		Reserved
	—	O5		Reserved
	—	O6		Reserved
—	O7	Reserved		

## Pin Definition and Functions BGA516 Package Variant Pin Configuration

Table 2-17 Port 30 Functions

Ball	Symbol	Ctrl.	Buffer Type	Function
AJ21	P30.0	I	FAST / PU1 / VEXT / ES	General-purpose input
	GTM_TIM4_IN0_10			Mux input channel 0 of TIM module 4
	P30.0	O0		General-purpose output
	GTM_TOUT190	O1		GTM muxed output
	—	O2		Reserved
	—	O3		Reserved
	—	O4		Reserved
	—	O5		Reserved
	—	O6		Reserved
	—	O7		Reserved
AK21	P30.1	I	FAST / PU1 / VEXT / ES	General-purpose input
	GTM_TIM4_IN1_10			Mux input channel 1 of TIM module 4
	P30.1	O0		General-purpose output
	GTM_TOUT191	O1		GTM muxed output
	—	O2		Reserved
	—	O3		Reserved
	—	O4		Reserved
	—	O5		Reserved
	—	O6		Reserved
	—	O7		Reserved
AJ22	P30.2	I	FAST / PU1 / VEXT / ES	General-purpose input
	GTM_TIM4_IN2_10			Mux input channel 2 of TIM module 4
	P30.2	O0		General-purpose output
	GTM_TOUT192	O1		GTM muxed output
	—	O2		Reserved
	—	O3		Reserved
	—	O4		Reserved
	—	O5		Reserved
	—	O6		Reserved
	—	O7		Reserved

## Pin Definition and Functions BGA516 Package Variant Pin Configuration

Table 2-17 Port 30 Functions (cont'd)

Ball	Symbol	Ctrl.	Buffer Type	Function
AK22	P30.3	I	FAST / PU1 / VEXT / ES	General-purpose input
	GTM_TIM4_IN3_10			Mux input channel 3 of TIM module 4
	P30.3	O0		General-purpose output
	GTM_TOUT193	O1		GTM muxed output
	—	O2		Reserved
	—	O3		Reserved
	—	O4		Reserved
	—	O5		Reserved
	—	O6		Reserved
	—	O7		Reserved
AJ23	P30.4	I	FAST / PU1 / VEXT / ES	General-purpose input
	GTM_TIM4_IN4_9			Mux input channel 4 of TIM module 4
	P30.4	O0		General-purpose output
	GTM_TOUT194	O1		GTM muxed output
	—	O2		Reserved
	—	O3		Reserved
	—	O4		Reserved
	—	O5		Reserved
	—	O6		Reserved
	—	O7		Reserved
AK23	P30.5	I	FAST / PU1 / VEXT / ES	General-purpose input
	GTM_TIM4_IN5_9			Mux input channel 5 of TIM module 4
	P30.5	O0		General-purpose output
	GTM_TOUT195	O1		GTM muxed output
	—	O2		Reserved
	—	O3		Reserved
	—	O4		Reserved
	—	O5		Reserved
	—	O6		Reserved
	—	O7		Reserved

## Pin Definition and Functions BGA516 Package Variant Pin Configuration

Table 2-17 Port 30 Functions (cont'd)

Ball	Symbol	Ctrl.	Buffer Type	Function
AJ24	P30.6	I	FAST / PU1 / VEXT / ES	General-purpose input
	GTM_TIM4_IN6_9			Mux input channel 6 of TIM module 4
	P30.6	O0		General-purpose output
	GTM_TOUT196	O1		GTM muxed output
	—	O2		Reserved
	—	O3		Reserved
	—	O4		Reserved
	—	O5		Reserved
	—	O6		Reserved
	—	O7		Reserved
AK24	P30.7	I	FAST / PU1 / VEXT / ES	General-purpose input
	GTM_TIM4_IN7_9			Mux input channel 7 of TIM module 4
	P30.7	O0		General-purpose output
	GTM_TOUT197	O1		GTM muxed output
	—	O2		Reserved
	—	O3		Reserved
	—	O4		Reserved
	—	O5		Reserved
	—	O6		Reserved
	—	O7		Reserved
AJ25	P30.8	I	FAST / PU1 / VEXT / ES	General-purpose input
	GTM_TIM6_IN0_8			Mux input channel 0 of TIM module 6
	GTM_TIM5_IN0_6			Mux input channel 0 of TIM module 5
	P30.8	O0		General-purpose output
	GTM_TOUT198	O1		GTM muxed output
	—	O2		Reserved
	—	O3		Reserved
	—	O4		Reserved
	—	O5		Reserved
	—	O6		Reserved
—	O7	Reserved		

## Pin Definition and Functions BGA516 Package Variant Pin Configuration

Table 2-17 Port 30 Functions (cont'd)

Ball	Symbol	Ctrl.	Buffer Type	Function
AK25	P30.9	I	FAST / PU1 / VEXT / ES	General-purpose input
	GTM_TIM6_IN1_8			Mux input channel 1 of TIM module 6
	GTM_TIM5_IN1_7			Mux input channel 1 of TIM module 5
	P30.9	O0		General-purpose output
	GTM_TOUT199	O1		GTM muxed output
	—	O2		Reserved
	—	O3		Reserved
	—	O4		Reserved
	—	O5		Reserved
	—	O6		Reserved
—	O7	Reserved		
AJ26	P30.10	I	FAST / PU1 / VEXT / ES	General-purpose input
	GTM_TIM6_IN2_8			Mux input channel 2 of TIM module 6
	GTM_TIM5_IN2_6			Mux input channel 2 of TIM module 5
	P30.10	O0		General-purpose output
	GTM_TOUT200	O1		GTM muxed output
	—	O2		Reserved
	—	O3		Reserved
	—	O4		Reserved
	—	O5		Reserved
	—	O6		Reserved
—	O7	Reserved		
AK26	P30.11	I	FAST / PU1 / VEXT / ES	General-purpose input
	GTM_TIM6_IN3_8			Mux input channel 3 of TIM module 6
	GTM_TIM5_IN3_7			Mux input channel 3 of TIM module 5
	P30.11	O0		General-purpose output
	GTM_TOUT201	O1		GTM muxed output
	—	O2		Reserved
	—	O3		Reserved
	—	O4		Reserved
	—	O5		Reserved
	—	O6		Reserved
—	O7	Reserved		

## Pin Definition and Functions BGA516 Package Variant Pin Configuration

Table 2-17 Port 30 Functions (cont'd)

Ball	Symbol	Ctrl.	Buffer Type	Function
AJ27	P30.12	I	FAST / PU1 / VEXT / ES	General-purpose input
	GTM_TIM6_IN4_7			Mux input channel 4 of TIM module 6
	GTM_TIM5_IN4_7			Mux input channel 4 of TIM module 5
	P30.12	O0		General-purpose output
	GTM_TOUT202	O1		GTM muxed output
	—	O2		Reserved
	—	O3		Reserved
	—	O4		Reserved
	—	O5		Reserved
	—	O6		Reserved
—	O7	Reserved		
AK27	P30.13	I	FAST / PU1 / VEXT / ES	General-purpose input
	GTM_TIM6_IN5_7			Mux input channel 5 of TIM module 6
	GTM_TIM5_IN5_7			Mux input channel 5 of TIM module 5
	P30.13	O0		General-purpose output
	GTM_TOUT203	O1		GTM muxed output
	—	O2		Reserved
	—	O3		Reserved
	—	O4		Reserved
	—	O5		Reserved
	—	O6		Reserved
—	O7	Reserved		
AJ28	P30.14	I	FAST / PU1 / VEXT / ES	General-purpose input
	GTM_TIM6_IN6_7			Mux input channel 6 of TIM module 6
	GTM_TIM5_IN6_7			Mux input channel 6 of TIM module 5
	P30.14	O0		General-purpose output
	GTM_TOUT204	O1		GTM muxed output
	—	O2		Reserved
	—	O3		Reserved
	—	O4		Reserved
	—	O5		Reserved
	—	O6		Reserved
—	O7	Reserved		

## Pin Definition and Functions BGA516 Package Variant Pin Configuration

Table 2-17 Port 30 Functions (cont'd)

Ball	Symbol	Ctrl.	Buffer Type	Function
AK28	P30.15	I	FAST / PU1 / VEXT / ES	General-purpose input
	GTM_TIM6_IN7_7			Mux input channel 7 of TIM module 6
	GTM_TIM5_IN7_6			Mux input channel 7 of TIM module 5
	P30.15	O0		General-purpose output
	GTM_TOUT205	O1		GTM muxed output
	—	O2		Reserved
	—	O3		Reserved
	—	O4		Reserved
	—	O5		Reserved
	—	O6		Reserved
—	O7	Reserved		

Table 2-18 Port 31 Functions

Ball	Symbol	Ctrl.	Buffer Type	Function
AJ12	P31.0	I	FAST / PU1 / VEXT / ES	General-purpose input
	GTM_TIM2_IN0_13			Mux input channel 0 of TIM module 2
	P31.0			O0
	GTM_TOUT174	O1		GTM muxed output
	—	O2		Reserved
	—	O3		Reserved
	—	O4		Reserved
	—	O5		Reserved
	—	O6		Reserved
	—	O7		Reserved
AK12	P31.1	I	FAST / PU1 / VEXT / ES	General-purpose input
	GTM_TIM2_IN1_9			Mux input channel 1 of TIM module 2
	P31.1			O0
	GTM_TOUT175	O1		GTM muxed output
	—	O2		Reserved
	—	O3		Reserved
	—	O4		Reserved
	—	O5		Reserved
	—	O6		Reserved
	—	O7		Reserved

## Pin Definition and Functions BGA516 Package Variant Pin Configuration

Table 2-18 Port 31 Functions (cont'd)

Ball	Symbol	Ctrl.	Buffer Type	Function
AJ13	P31.2	I	FAST / PU1 / VEXT / ES	General-purpose input
	GTM_TIM2_IN2_9			Mux input channel 2 of TIM module 2
	P31.2	O0		General-purpose output
	GTM_TOUT176	O1		GTM muxed output
	—	O2		Reserved
	—	O3		Reserved
	—	O4		Reserved
	—	O5		Reserved
	—	O6		Reserved
	—	O7		Reserved
AK13	P31.3	I	FAST / PU1 / VEXT / ES	General-purpose input
	GTM_TIM2_IN3_14			Mux input channel 3 of TIM module 2
	P31.3	O0		General-purpose output
	GTM_TOUT177	O1		GTM muxed output
	—	O2		Reserved
	—	O3		Reserved
	—	O4		Reserved
	—	O5		Reserved
	—	O6		Reserved
	—	O7		Reserved
AJ14	P31.4	I	FAST / PU1 / VEXT / ES	General-purpose input
	GTM_TIM2_IN4_12			Mux input channel 4 of TIM module 2
	P31.4	O0		General-purpose output
	GTM_TOUT178	O1		GTM muxed output
	—	O2		Reserved
	—	O3		Reserved
	—	O4		Reserved
	—	O5		Reserved
	—	O6		Reserved
	—	O7		Reserved

## Pin Definition and Functions BGA516 Package Variant Pin Configuration

Table 2-18 Port 31 Functions (cont'd)

Ball	Symbol	Ctrl.	Buffer Type	Function
AK14	P31.5	I	FAST / PU1 / VEXT / ES	General-purpose input
	GTM_TIM2_IN5_13			Mux input channel 5 of TIM module 2
	P31.5	O0		General-purpose output
	GTM_TOUT179	O1		GTM muxed output
	—	O2		Reserved
	—	O3		Reserved
	—	O4		Reserved
	—	O5		Reserved
	—	O6		Reserved
	—	O7		Reserved
AJ15	P31.6	I	FAST / PU1 / VEXT / ES	General-purpose input
	GTM_TIM2_IN6_12			Mux input channel 6 of TIM module 2
	P31.6	O0		General-purpose output
	GTM_TOUT180	O1		GTM muxed output
	—	O2		Reserved
	—	O3		Reserved
	—	O4		Reserved
	—	O5		Reserved
	—	O6		Reserved
	—	O7		Reserved
AK15	P31.7	I	FAST / PU1 / VEXT / ES	General-purpose input
	GTM_TIM2_IN7_14			Mux input channel 7 of TIM module 2
	P31.7	O0		General-purpose output
	GTM_TOUT181	O1		GTM muxed output
	—	O2		Reserved
	—	O3		Reserved
	—	O4		Reserved
	—	O5		Reserved
	—	O6		Reserved
	—	O7		Reserved

## Pin Definition and Functions BGA516 Package Variant Pin Configuration

Table 2-18 Port 31 Functions (cont'd)

Ball	Symbol	Ctrl.	Buffer Type	Function
AJ16	P31.8	I	FAST / PU1 / VEXT / ES	General-purpose input
	GTM_TIM6_IN0_9			Mux input channel 0 of TIM module 6
	GTM_TIM5_IN0_7			Mux input channel 0 of TIM module 5
	SENT_SENT20C			Receive input channel 20
	P31.8	O0		General-purpose output
	GTM_TOUT182	O1		GTM muxed output
	—	O2		Reserved
	—	O3		Reserved
	—	O4		Reserved
	—	O5		Reserved
	—	O6		Reserved
—	O7	Reserved		
AK16	P31.9	I	FAST / PU1 / VEXT / ES	General-purpose input
	GTM_TIM6_IN1_9			Mux input channel 1 of TIM module 6
	GTM_TIM5_IN1_8			Mux input channel 1 of TIM module 5
	SENT_SENT21C			Receive input channel 21
	P31.9	O0		General-purpose output
	GTM_TOUT183	O1		GTM muxed output
	—	O2		Reserved
	—	O3		Reserved
	—	O4		Reserved
	—	O5		Reserved
	—	O6		Reserved
—	O7	Reserved		
AJ17	P31.10	I	FAST / PU1 / VEXT / ES	General-purpose input
	GTM_TIM6_IN2_9			Mux input channel 2 of TIM module 6
	GTM_TIM5_IN2_7			Mux input channel 2 of TIM module 5
	SENT_SENT22C			Receive input channel 22
	P31.10	O0		General-purpose output
	GTM_TOUT184	O1		GTM muxed output
	—	O2		Reserved
	—	O3		Reserved
	—	O4		Reserved
	—	O5		Reserved
	—	O6		Reserved
—	O7	Reserved		

## Pin Definition and Functions BGA516 Package Variant Pin Configuration

Table 2-18 Port 31 Functions (cont'd)

Ball	Symbol	Ctrl.	Buffer Type	Function
AK17	P31.11	I	FAST / PU1 / VEXT / ES	General-purpose input
	GTM_TIM6_IN3_9			Mux input channel 3 of TIM module 6
	GTM_TIM5_IN3_8			Mux input channel 3 of TIM module 5
	SENT_SENT23C			Receive input channel 23
	P31.11	O0		General-purpose output
	GTM_TOUT185	O1		GTM muxed output
	—	O2		Reserved
	—	O3		Reserved
	—	O4		Reserved
	—	O5		Reserved
	—	O6		Reserved
	—	O7		Reserved
AJ18	P31.12	I	FAST / PU1 / VEXT / ES	General-purpose input
	GTM_TIM6_IN4_8			Mux input channel 4 of TIM module 6
	GTM_TIM5_IN4_8			Mux input channel 4 of TIM module 5
	SENT_SENT24C			Receive input channel 24
	P31.12	O0		General-purpose output
	GTM_TOUT186	O1		GTM muxed output
	—	O2		Reserved
	—	O3		Reserved
	—	O4		Reserved
	—	O5		Reserved
	—	O6		Reserved
	—	O7		Reserved
AK18	P31.13	I	FAST / PU1 / VEXT / ES	General-purpose input
	GTM_TIM6_IN5_8			Mux input channel 5 of TIM module 6
	GTM_TIM5_IN5_8			Mux input channel 5 of TIM module 5
	P31.13			O0
	GTM_TOUT187	O1		GTM muxed output
	—	O2		Reserved
	—	O3		Reserved
	—	O4		Reserved
	—	O5		Reserved
	—	O6		Reserved
	—	O7		Reserved

## Pin Definition and Functions BGA516 Package Variant Pin Configuration

Table 2-18 Port 31 Functions (cont'd)

Ball	Symbol	Ctrl.	Buffer Type	Function
AJ19	P31.14	I	FAST / PU1 / VEXT / ES	General-purpose input
	GTM_TIM6_IN6_8			Mux input channel 6 of TIM module 6
	GTM_TIM5_IN6_8			Mux input channel 6 of TIM module 5
	P31.14	O0		General-purpose output
	GTM_TOUT188	O1		GTM muxed output
	—	O2		Reserved
	—	O3		Reserved
	—	O4		Reserved
	—	O5		Reserved
	—	O6		Reserved
—	O7	Reserved		
AK19	P31.15	I	FAST / PU1 / VEXT / ES	General-purpose input
	GTM_TIM6_IN7_8			Mux input channel 7 of TIM module 6
	GTM_TIM5_IN7_7			Mux input channel 7 of TIM module 5
	P31.15	O0		General-purpose output
	GTM_TOUT189	O1		GTM muxed output
	—	O2		Reserved
	—	O3		Reserved
	—	O4		Reserved
	—	O5		Reserved
	—	O6		Reserved
—	O7	Reserved		

## Pin Definition and Functions BGA516 Package Variant Pin Configuration

Table 2-19 Port 32 Functions

Ball	Symbol	Ctrl.	Buffer Type	Function
AE22	P32.0	I	SLOW / PU1 / VEXT / ES	<b>General-purpose input</b> P32.0 / SMPS mode: analog output. External Pass Device gate control for EVRC
	GTM_TIM3_IN2_5			<b>Mux input channel 2 of TIM module 3</b>
	GTM_TIM2_IN2_5			<b>Mux input channel 2 of TIM module 2</b>
	P32.0	O0		<b>General-purpose output</b>
	GTM_TOUT36	O1		<b>GTM muxed output</b>
	—	O2		<b>Reserved</b>
	—	O3		<b>Reserved</b>
	—	O4		<b>Reserved</b>
	—	O5		<b>Reserved</b>
	—	O6		<b>Reserved</b>
—	O7	<b>Reserved</b>		
AD22	P32.1	I	SLOW / PU1 / VEXT / ES	<b>General-purpose input</b> P32.1 / External Pass Device gate control for EVRC
	GTM_TIM3_IN3_15			<b>Mux input channel 3 of TIM module 3</b>
	P32.1	O0		<b>General-purpose output</b>
	GTM_TOUT37	O1		<b>GTM muxed output</b>
	—	O2		<b>Reserved</b>
	—	O3		<b>Reserved</b>
	—	O4		<b>Reserved</b>
	—	O5		<b>Reserved</b>
	—	O6		<b>Reserved</b>
	—	O7		<b>Reserved</b>

## Pin Definition and Functions BGA516 Package Variant Pin Configuration

Table 2-19 Port 32 Functions (cont'd)

Ball	Symbol	Ctrl.	Buffer Type	Function
AE23	P32.2	I	SLOW / PU1 / VEXT / ES	General-purpose input
	GTM_TIM1_IN3_8			Mux input channel 3 of TIM module 1
	GTM_TIM0_IN3_8			Mux input channel 3 of TIM module 0
	CAN03_RXDB			CAN receive input node 3
	ASCLIN3_ARXD			Receive input
	CAN21_RXDD			CAN receive input node 1
	P32.2	O0	General-purpose output	
	GTM_TOUT38	O1	GTM muxed output	
	ASCLIN3_ATX	O2	Transmit output	
	IOM_MON2_15		Monitor input 2	
	IOM_REF2_15		Reference input 2	
	—	O3	Reserved	
	—	O4	Reserved	
	—	O5	Reserved	
	PMS_DCDCSYNCO	O6	DC-DC synchronization output	
—	O7	Reserved		
AE24	P32.3	I	SLOW / PU1 / VEXT / ES	General-purpose input
	GTM_TIM1_IN4_5			Mux input channel 4 of TIM module 1
	GTM_TIM0_IN4_5			Mux input channel 4 of TIM module 0
	P32.3	O0	General-purpose output	
	GTM_TOUT39	O1	GTM muxed output	
	ASCLIN3_ATX	O2	Transmit output	
	IOM_MON2_15		Monitor input 2	
	IOM_REF2_15		Reference input 2	
	—	O3	Reserved	
	ASCLIN3_ASCLK	O4	Shift clock output	
	CAN03_TXD	O5	CAN transmit output node 3	
	IOM_MON2_8		Monitor input 2	
	IOM_REF2_8		Reference input 2	
	CAN21_TXD	O6	CAN transmit output node 1	
	—	O7	Reserved	

## Pin Definition and Functions BGA516 Package Variant Pin Configuration

Table 2-19 Port 32 Functions (cont'd)

Ball	Symbol	Ctrl.	Buffer Type	Function
AD23	P32.4	I	FAST / PU1 / VEXT / ES	General-purpose input
	GTM_TIM1_IN5_5			Mux input channel 5 of TIM module 1
	GTM_TIM0_IN5_5			Mux input channel 5 of TIM module 0
	ASCLIN1_ACTSB			Clear to send input
	MSC1_SDI2			Upstream asynchronous input signal
	ASCLIN15_ARXA			Receive input
	P32.4	O0	General-purpose output	
	GTM_TOUT40	O1	GTM muxed output	
	PMS_DCDCSYNCO	O2	DC-DC synchronization output	
	—	O3	Reserved	
	GTM_CLK1	O4	CGM generated clock	
	MSC1_EN0	O5	Chip Select	
	CCU_EXTCLK1	O6	External Clock 1	
	CCU60_COUT63	O7	T13 PWM channel 63	
IOM_MON1_6		Monitor input 1		
IOM_REF1_0		Reference input 1		
AA20	P32.5	I	SLOW / PU1 / VEXT / ES	General-purpose input
	GTM_TIM5_IN5_9			Mux input channel 5 of TIM module 5
	GTM_TIM4_IN1_14			Mux input channel 1 of TIM module 4
	GTM_TIM3_IN5_8			Mux input channel 5 of TIM module 3
	SENT_SENT10C			Receive input channel 10
	P32.5	O0	General-purpose output	
	GTM_TOUT140	O1	GTM muxed output	
	ASCLIN2_ATX	O2	Transmit output	
	IOM_MON2_14		Monitor input 2	
	IOM_REF2_14		Reference input 2	
	—	O3	Reserved	
	—	O4	Reserved	
	—	O5	Reserved	
	CAN02_TXD	O6	CAN transmit output node 2	
IOM_MON2_7		Monitor input 2		
IOM_REF2_7		Reference input 2		
—	O7	Reserved		

## Pin Definition and Functions BGA516 Package Variant Pin Configuration

Table 2-19 Port 32 Functions (cont'd)

Ball	Symbol	Ctrl.	Buffer Type	Function	
AB20	P32.6	I	SLOW / PU1 / VEXT / ES	General-purpose input	
	GTM_TIM5_IN6_9			Mux input channel 6 of TIM module 5	
	GTM_TIM4_IN4_15			Mux input channel 4 of TIM module 4	
	GTM_TIM3_IN6_8			Mux input channel 6 of TIM module 3	
	CAN02_RXDC			CAN receive input node 2	
	CBS_TGI4			Trigger input	
	ASCLIN2_ARXF			Receive input	
	ASCLIN6_ARXC			Receive input	
	SENT_SENT11C			Receive input channel 11	
	P32.6			O0	General-purpose output
	GTM_TOUT141	O1	GTM muxed output		
	—	O2	Reserved		
	—	O3	Reserved		
	QSPI2_SLSO12	O4	Master slave select output		
	CAN22_TXD	O5	CAN transmit output node 2		
	—	O6	Reserved		
	—	O7	Reserved		
	CBS_TGO4	O	Trigger output		
	AB21	P32.7	I	SLOW / PU1 / VEXT / ES	General-purpose input
GTM_TIM5_IN7_8		Mux input channel 7 of TIM module 5			
GTM_TIM4_IN0_15		Mux input channel 0 of TIM module 4			
GTM_TIM3_IN7_8		Mux input channel 7 of TIM module 3			
CBS_TGI5		Trigger input			
CAN22_RXDB		CAN receive input node 2			
SENT_SENT12C		Receive input channel 12			
ASCLIN15_ARXB		Receive input			
P32.7		O0			General-purpose output
GTM_TOUT142		O1			GTM muxed output
ASCLIN6_ATX		O2	Transmit output		
—		O3	Reserved		
ASCLIN15_ATX		O4	Transmit output		
—		O5	Reserved		
—		O6	Reserved		
—		O7	Reserved		
CBS_TGO5		O	Trigger output		

## Pin Definition and Functions BGA516 Package Variant Pin Configuration

Table 2-20 Port 33 Functions

Ball	Symbol	Ctrl.	Buffer Type	Function
AD15	P33.0	I	SLOW / PU1 / VEVRSB / ES5	<b>General-purpose input</b>
	GTM_TIM3_IN0_13			<b>Mux input channel 0 of TIM module 3</b>
	GTM_TIM1_IN4_6			<b>Mux input channel 4 of TIM module 1</b>
	GTM_TIM0_IN4_6			<b>Mux input channel 4 of TIM module 0</b>
	EDSADC_ITR0E			<b>Trigger/Gate input, channel 0</b>
	SENT_SENT13C			<b>Receive input channel 13</b>
	IOM_PIN_0			<b>GPIO pad input to FPC</b>
	GTM_DTMT1_2			<b>CDTM1_DTM0</b>
	EVADC_G10CH7			AI
	P33.0	O0	<b>General-purpose output</b>	
	GTM_TOUT22	O1	<b>GTM muxed output</b>	
	IOM_MON0_0		<b>Monitor input 0</b>	
	IOM_GTM_0		<b>GTM-provided inputs to EXOR combiner</b>	
	ASCLIN5_ATX	O2	<b>Transmit output</b>	
	—	O3	<b>Reserved</b>	
	ASCLIN15_ATX	O4	<b>Transmit output</b>	
	—	O5	<b>Reserved</b>	
	EVADC_FC2BFLOUT	O6	<b>Boundary flag output, FC channel 2</b>	
	—	O7	<b>Reserved</b>	

## Pin Definition and Functions BGA516 Package Variant Pin Configuration

Table 2-20 Port 33 Functions (cont'd)

Ball	Symbol	Ctrl.	Buffer Type	Function
AE15	P33.1	I	SLOW / PU1 / VEVRSB / ES5	General-purpose input
	GTM_TIM3_IN1_15			Mux input channel 1 of TIM module 3
	GTM_TIM1_IN5_6			Mux input channel 5 of TIM module 1
	GTM_TIM0_IN5_6			Mux input channel 5 of TIM module 0
	EDSADC_ITR1E			Trigger/Gate input, channel 1
	PSI5_RX0C			RXD inputs (receive data) channel 0
	EDSADC_DSCIN2B			Modulator clock input, channel 2
	SENT_SENT9C			Receive input channel 9
	ASCLIN8_ARXC			Receive input
	IOM_PIN_1			GPIO pad input to FPC
	EVADC_G10CH6			AI
	P33.1	O0	General-purpose output	
	GTM_TOUT23	O1	GTM muxed output	
	IOM_MON0_1		Monitor input 0	
	IOM_GTM_1		GTM-provided inputs to EXOR combiner	
	ASCLIN3_ASLSO	O2	Slave select signal output	
	QSPI2_SCLK	O3	Master SPI clock output	
	EDSADC_DSCOUT2	O4	Modulator clock output	
	EVADC_EMUX02	O5	Control of external analog multiplexer interface 0	
	—	O6	Reserved	
—	O7	Reserved		

## Pin Definition and Functions BGA516 Package Variant Pin Configuration

Table 2-20 Port 33 Functions (cont'd)

Ball	Symbol	Ctrl.	Buffer Type	Function
AD16	P33.2	I	SLOW / PU1 / VEVRSB / ES5	General-purpose input
	GTM_TIM3_IN2_14			Mux input channel 2 of TIM module 3
	GTM_TIM1_IN6_6			Mux input channel 6 of TIM module 1
	GTM_TIM0_IN6_6			Mux input channel 6 of TIM module 0
	EDSADC_ITR2E			Trigger/Gate input, channel 2
	SENT_SENT8C			Receive input channel 8
	EDSADC_DSDIN2B			Digital datastream input, channel 2
	IOM_PIN_2			GPIO pad input to FPC
	EVADC_G10CH5	AI	Analog input channel 5, group 10	
	P33.2	O0	General-purpose output	
	GTM_TOUT24	O1	GTM muxed output	
	IOM_MON0_2		Monitor input 0	
	IOM_GTM_2		GTM-provided inputs to EXOR combiner	
	ASCLIN3_ASCLK	O2	Shift clock output	
	QSPI2_SLSO10	O3	Master slave select output	
	PSI5_TX0	O4	TXD outputs (send data)	
	IOM_MON1_14		Monitor input 1	
	IOM_REF1_14		Reference input 1	
	EVADC_EMUX01	O5	Control of external analog multiplexer interface 0	
	EVADC_FC3BFLOUT	O6	Boundary flag output, FC channel 3	
ASCLIN14_ATX	O7	Transmit output		

## Pin Definition and Functions BGA516 Package Variant Pin Configuration

Table 2-20 Port 33 Functions (cont'd)

Ball	Symbol	Ctrl.	Buffer Type	Function
AE16	P33.3	I	SLOW / PU1 / VEVRSB / ES5	General-purpose input
	GTM_TIM3_IN3_12			Mux input channel 3 of TIM module 3
	GTM_TIM1_IN7_6			Mux input channel 7 of TIM module 1
	GTM_TIM0_IN7_6			Mux input channel 7 of TIM module 0
	PSI5_RX1C			RXD inputs (receive data) channel 1
	SENT_SENT7C			Receive input channel 7
	EDSADC_DSCIN1B			Modulator clock input, channel 1
	ASCLIN14_ARXA			Receive input
	IOM_PIN_3			GPIO pad input to FPC
	EVADC_G10CH4			Analog input channel 4, group 10
	P33.3	O0	General-purpose output	
	GTM_TOUT25	O1	GTM muxed output	
	IOM_MON0_3		Monitor input 0	
	IOM_GTM_3		GTM-provided inputs to EXOR combiner	
	ASCLIN5_ASCLK	O2	Shift clock output	
	QSPI4_SLSO2	O3	Master slave select output	
	EDSADC_DSCOUT1	O4	Modulator clock output	
	EVADC_EMUX00	O5	Control of external analog multiplexer interface 0	
	—	O6	Reserved	
	ASCLIN14_ATX	O7	Transmit output	

## Pin Definition and Functions BGA516 Package Variant Pin Configuration

Table 2-20 Port 33 Functions (cont'd)

Ball	Symbol	Ctrl.	Buffer Type	Function
AD17	P33.4	I	SLOW / PU1 / VEVRSB / ES5	General-purpose input
	GTM_TIM4_IN4_10			Mux input channel 4 of TIM module 4
	GTM_TIM1_IN0_10			Mux input channel 0 of TIM module 1
	GTM_TIM0_IN0_10			Mux input channel 0 of TIM module 0
	EDSADC_ITR0F			Trigger/Gate input, channel 0
	SENT_SENT6C			Receive input channel 6
	EDSADC_DSDIN1B			Digital datastream input, channel 1
	CCU61_CTRAPC			Trap input capture
	ASCLIN5_ARXB			Receive input
	ASCLIN14_ARXB			Receive input
	IOM_PIN_4			GPIO pad input to FPC
	GTM_DTMT2_0			CDTM2_DTM0
	EVADC_G10CH3			AI
	P33.4	O0	General-purpose output	
	GTM_TOUT26	O1	GTM muxed output	
	IOM_MON0_4		Monitor input 0	
	IOM_GTM_4		GTM-provided inputs to EXOR combiner	
	ASCLIN2_ARTS	O2	Ready to send output	
	QSPI2_SLSO12	O3	Master slave select output	
	PSI5_TX1	O4	TXD outputs (send data)	
IOM_MON1_15		Monitor input 1		
EVADC_EMUX12	O5	Control of external analog multiplexer interface 1		
EVADC_FC0BFLOUT	O6	Boundary flag output, FC channel 0		
CAN13_TXD	O7	CAN transmit output node 3		

## Pin Definition and Functions BGA516 Package Variant Pin Configuration

Table 2-20 Port 33 Functions (cont'd)

Ball	Symbol	Ctrl.	Buffer Type	Function
AE17	P33.5	I	SLOW / PU1 / VEVRSB / ES5	General-purpose input
	GTM_TIM4_IN5_10			Mux input channel 5 of TIM module 4
	GTM_TIM1_IN1_8			Mux input channel 1 of TIM module 1
	GTM_TIM0_IN1_8			Mux input channel 1 of TIM module 0
	EDSADC_DSCIN0B			Modulator clock input, channel 0
	EDSADC_ITR1F			Trigger/Gate input, channel 1
	GPT120_T4EADB			Count direction control input of timer T4
	PSI5S_RXC			RX data input
	ASCLIN2_ACTSB			Clear to send input
	CCU61_CCPOS2C			Hall capture input 2
	PSI5_RX2C			RXD inputs (receive data) channel 2
	SENT_SENT5C			Receive input channel 5
	CAN13_RXDB			CAN receive input node 3
	IOM_PIN_5			GPIO pad input to FPC
	EVADC_G10CH2	AI	Analog input channel 2, group 10	
	P33.5	O0	General-purpose output	
	GTM_TOUT27	O1	GTM muxed output	
	IOM_MON0_5		Monitor input 0	
	IOM_GTM_5		GTM-provided inputs to EXOR combiner	
	QSPIO_SLSO7	O2	Master slave select output	
QSPI1_SLSO7	O3	Master slave select output		
EDSADC_DSCOUT0	O4	Modulator clock output		
EVADC_EMUX11	O5	Control of external analog multiplexer interface 1		
EVADC_FC2BFLOUT	O6	Boundary flag output, FC channel 2		
ASCLIN5_ASLSO	O7	Slave select signal output		

## Pin Definition and Functions BGA516 Package Variant Pin Configuration

Table 2-20 Port 33 Functions (cont'd)

Ball	Symbol	Ctrl.	Buffer Type	Function	
AD18	P33.6	I	SLOW / PU1 / VEVRSB / ES5	General-purpose input	
	GTM_TIM1_IN2_9			Mux input channel 2 of TIM module 1	
	GTM_TIM0_IN2_9			Mux input channel 2 of TIM module 0	
	EDSADC_ITR2F			Trigger/Gate input, channel 2	
	GPT120_T2EUDB			Count direction control input of timer T2	
	SENT_SENT4C			Receive input channel 4	
	CCU61_CCPOS1C			Hall capture input 1	
	EDSADC_DSDIN0B			Digital datastream input, channel 0	
	ASCLIN8_ARXD			Receive input	
	IOM_PIN_6			GPIO pad input to FPC	
	GTM_DTMT2_1			CDTM2_DTM0	
	EVADC_G10CH1			AI	Analog input channel 1, group 10
	P33.6			O0	General-purpose output
	GTM_TOUT28	O1	GTM muxed output		
	IOM_MON0_6		Monitor input 0		
	IOM_GTM_6		GTM-provided inputs to EXOR combiner		
	ASCLIN2_ASLSO	O2	Slave select signal output		
	QSPI2_SLSO11	O3	Master slave select output		
	PSI5_TX2	O4	TXD outputs (send data)		
	IOM_REF1_15	O5	Reference input 1		
EVADC_EMUX10	Control of external analog multiplexer interface 1				
EVADC_FC1BFLOUT	O6		Boundary flag output, FC channel 1		
PSI5S_TX	O7	TX data output			

## Pin Definition and Functions BGA516 Package Variant Pin Configuration

Table 2-20 Port 33 Functions (cont'd)

Ball	Symbol	Ctrl.	Buffer Type	Function
AE18	P33.7	I	SLOW / PU1 / VEVRSB / ES5	General-purpose input
	GTM_TIM1_IN3_9			Mux input channel 3 of TIM module 1
	GTM_TIM0_IN3_9			Mux input channel 3 of TIM module 0
	CAN00_RXDE			CAN receive input node 0
	GPT120_T2INB			Trigger/gate input of timer T2
	CCU61_CCPOS0C			Hall capture input 0
	SCU_E_REQ4_0			ERU Channel 4 inputs 0 to 5 (0 is the LSB and 5 is the MSB)
	SENT_SENT14C			Receive input channel 14
	IOM_PIN_7			GPIO pad input to FPC
	EVADC_G10CH0	AI	Analog input channel 0, group 10	
	P33.7	O0	General-purpose output	
	GTM_TOUT29	O1	GTM muxed output	
	IOM_MON0_7	O1	Monitor input 0	
	IOM_GTM_7		GTM-provided inputs to EXOR combiner	
	ASCLIN2_ASCLK	O2	Shift clock output	
	QSPI4_SLSO7	O3	Master slave select output	
	ASCLIN8_ATX	O4	Transmit output	
	—	O5	Reserved	
	EVADC_FC3BFLOUT	O6	Boundary flag output, FC channel 3	
—	O7	Reserved		

## Pin Definition and Functions BGA516 Package Variant Pin Configuration

Table 2-20 Port 33 Functions (cont'd)

Ball	Symbol	Ctrl.	Buffer Type	Function
AD19	P33.8	I	FAST / HighZ / VEVRSB	General-purpose input
	GTM_TIM1_IN4_7			Mux input channel 4 of TIM module 1
	GTM_TIM0_IN4_7			Mux input channel 4 of TIM module 0
	ASCLIN2_ARXE			Receive input
	SCU_EMGSTOP_PORT_A			Emergency stop Port Pin A input request
	IOM_PIN_8			GPIO pad input to FPC
	P33.8	O0	General-purpose output	
	GTM_TOUT30	O1	GTM muxed output	
	IOM_MON0_8	O2	Monitor input 0	
	ASCLIN2_ATX		Transmit output	
	IOM_MON2_14		Monitor input 2	
	IOM_REF2_14	Reference input 2		
	QSPI4_SLSO2	O3	Master slave select output	
	—	O4	Reserved	
	CAN00_TXD	O5	CAN transmit output node 0	
	IOM_MON2_5	O6	Monitor input 2	
	IOM_REF2_5		Reference input 2	
	—		Reserved	
	CCU61_COUT62	O7	T12 PWM channel 62	
	IOM_MON1_13	O	Monitor input 1	
IOM_REF1_8	Reference input 1			
SMU_FSP0		FSP[1..0] Output Signals - Generated by SMU_core		

## Pin Definition and Functions BGA516 Package Variant Pin Configuration

Table 2-20 Port 33 Functions (cont'd)

Ball	Symbol	Ctrl.	Buffer Type	Function
AE19	P33.9	I	SLOW / PU1 / VEVRSB / ES5	General-purpose input
	GTM_TIM1_IN1_9			Mux input channel 1 of TIM module 1
	GTM_TIM0_IN1_9			Mux input channel 1 of TIM module 0
	IOM_PIN_9			GPIO pad input to FPC
	P33.9	O0	SLOW / PU1 / VEVRSB / ES5	General-purpose output
	GTM_TOUT31	O1		GTM muxed output
	IOM_MON0_9	O2		Monitor input 0
	ASCLIN2_ATX			Transmit output
	IOM_MON2_14			Monitor input 2
	IOM_REF2_14	O3		Reference input 2
	QSPI4_SLSO1			Master slave select output
	ASCLIN2_ASCLK	O4		Shift clock output
	CAN01_TXD	O5		CAN transmit output node 1
	IOM_MON2_6			Monitor input 2
	IOM_REF2_6			Reference input 2
	ASCLIN0_ATX	O6		Transmit output
	IOM_MON2_12			Monitor input 2
	IOM_REF2_12			Reference input 2
	CCU61_CC62	O7		T12 PWM channel 62
	IOM_MON1_10			Monitor input 1
IOM_REF1_11	Reference input 1			

## Pin Definition and Functions BGA516 Package Variant Pin Configuration

Table 2-20 Port 33 Functions (cont'd)

Ball	Symbol	Ctrl.	Buffer Type	Function
AD20	P33.10	I	FAST / PU1 / VEVRSB / ES5	General-purpose input
	GTM_TIM4_IN4_14			Mux input channel 4 of TIM module 4
	GTM_TIM1_IN0_9			Mux input channel 0 of TIM module 1
	GTM_TIM0_IN0_9			Mux input channel 0 of TIM module 0
	QSPI4_SLSIA			Slave select input
	CAN01_RXDD			CAN receive input node 1
	ASCLIN0_ARXD			Receive input
	IOM_PIN_10			GPIO pad input to FPC
	P33.10			O0
	GTM_TOUT32	O1	GTM muxed output	
	IOM_MON0_10	O2	Monitor input 0	
	QSPI1_SLSO6		Master slave select output	
	QSPI4_SLSO0		Master slave select output	
	ASCLIN1_ASLSO	O4	Slave select signal output	
	PSI5S_CLK	O5	PSI5S CLK is a clock that can be used on a pin to drive the external PHY.	
	—	O6	Reserved	
	CCU61_COUT61	O7	T12 PWM channel 61	
	IOM_MON1_12		Monitor input 1	
	IOM_REF1_9		Reference input 1	
SMU_FSP1	O	FSP[1..0] Output Signals - Generated by SMU_core		
AE20	P33.11	I	FAST / PU1 / VEVRSB / ES5	General-purpose input
	GTM_TIM1_IN2_8			Mux input channel 2 of TIM module 1
	GTM_TIM0_IN2_8			Mux input channel 2 of TIM module 0
	QSPI4_SCLKA			Slave SPI clock inputs
	IOM_PIN_11			GPIO pad input to FPC
	P33.11	O0	General-purpose output	
	GTM_TOUT33	O1	GTM muxed output	
	IOM_MON0_11	O2	Monitor input 0	
	ASCLIN1_ASCLK		Shift clock output	
	QSPI4_SCLK		Master SPI clock output	
	—	O4	Reserved	
	—	O5	Reserved	
	EDSADC_CGPWMN	O6	Negative carrier generator output	
	CCU61_CC61	O7	T12 PWM channel 61	
	IOM_MON1_9		Monitor input 1	
IOM_REF1_12	Reference input 1			

## Pin Definition and Functions BGA516 Package Variant Pin Configuration

Table 2-20 Port 33 Functions (cont'd)

Ball	Symbol	Ctrl.	Buffer Type	Function
AD21	P33.12	I	FAST / PU1 / VEVRSB / ES5	General-purpose input
	GTM_TIM3_IN0_6			Mux input channel 0 of TIM module 3
	GTM_TIM2_IN0_6			Mux input channel 0 of TIM module 2
	QSPI4_MTSRA			Slave SPI data input
	CAN00_RXDD			CAN receive input node 0
	PMS_PINBWKP			PINB (P33.12) pin input
	IOM_PIN_12			GPIO pad input to FPC
	P33.12	O0	General-purpose output	
	GTM_TOUT34	O1	GTM muxed output	
	IOM_MON0_12	O2	Monitor input 0	
	ASCLIN1_ATX		Transmit output	
	IOM_MON2_13		Monitor input 2	
	IOM_REF2_13	Reference input 2		
	QSPI4_MTSR	O3	Master SPI data output	
	ASCLIN1_ASCLK	O4	Shift clock output	
	CAN22_TXD	O5	CAN transmit output node 2	
	EDSADC_CGPWMP	O6	Positive carrier generator output	
	CCU61_COUT60	O7	T12 PWM channel 60	
	IOM_MON1_11		Monitor input 1	
	IOM_REF1_10		Reference input 1	

## Pin Definition and Functions BGA516 Package Variant Pin Configuration

Table 2-20 Port 33 Functions (cont'd)

Ball	Symbol	Ctrl.	Buffer Type	Function
AE21	P33.13	I	FAST / PU1 / VEVRSB / ES5	General-purpose input
	GTM_TIM3_IN1_5			Mux input channel 1 of TIM module 3
	GTM_TIM2_IN1_5			Mux input channel 1 of TIM module 2
	ASCLIN1_ARXF			Receive input
	EDSADC_SGNB			Carrier sign signal input
	QSPI4_MRSTA			Master SPI data input
	MSC1_INJ1			Injection signal from port
	CAN22_RXDA			CAN receive input node 2
	P33.13	O0	General-purpose output	
	GTM_TOUT35	O1	GTM muxed output	
	ASCLIN1_ATX	O2	Transmit output	
	IOM_MON2_13	O2	Monitor input 2	
	IOM_REF2_13		Reference input 2	
	QSPI4_MRST	O3	Slave SPI data output	
	IOM_MON2_4	O3	Monitor input 2	
	IOM_REF2_4		Reference input 2	
	QSPI2_SLSO6	O4	Master slave select output	
	CAN00_TXD	O5	CAN transmit output node 0	
	IOM_MON2_5	O5	Monitor input 2	
	IOM_REF2_5		Reference input 2	
	—	O6	Reserved	
	CCU61_CC60	O7	T12 PWM channel 60	
	IOM_MON1_8	O7	Monitor input 1	
IOM_REF1_13	Reference input 1			

## Pin Definition and Functions BGA516 Package Variant Pin Configuration

Table 2-20 Port 33 Functions (cont'd)

Ball	Symbol	Ctrl.	Buffer Type	Function
AA19	P33.14	I	FAST / PU1 / VEVR SB / ES5	General-purpose input
	GTM_TIM5_IN0_8			Mux input channel 0 of TIM module 5
	GTM_TIM4_IN5_14			Mux input channel 5 of TIM module 4
	GTM_TIM2_IN0_8			Mux input channel 0 of TIM module 2
	QSPI2_SCLKD			Slave SPI clock inputs
	CBS_TGI6			Trigger input
	P33.14	O0	SLOW / PU1 / VEVR SB / ES5	General-purpose output
	GTM_TOUT143	O1		GTM muxed output
	—	O2		Reserved
	QSPI2_SCLK	O3		Master SPI clock output
	—	O4		Reserved
	—	O5		Reserved
	—	O6		Reserved
	CCU60_CC62	O7		T12 PWM channel 62
	IOM_MON1_0	O		Monitor input 1
	IOM_REF1_4			Reference input 1
CBS_TGO6	O	Trigger output		
AB19	P33.15	I	SLOW / PU1 / VEVR SB / ES5	General-purpose input
	GTM_TIM5_IN1_9			Mux input channel 1 of TIM module 5
	GTM_TIM4_IN6_12			Mux input channel 6 of TIM module 4
	GTM_TIM2_IN1_7			Mux input channel 1 of TIM module 2
	CBS_TGI7			Trigger input
	P33.15	O0	SLOW / PU1 / VEVR SB / ES5	General-purpose output
	GTM_TOUT144	O1		GTM muxed output
	—	O2		Reserved
	QSPI2_SLSO11	O3		Master slave select output
	—	O4		Reserved
	—	O5		Reserved
	—	O6		Reserved
	CCU60_COUT62	O7		T12 PWM channel 62
	IOM_MON1_5	O		Monitor input 1
	IOM_REF1_1			Reference input 1
	CBS_TGO7	O	Trigger output	

## Pin Definition and Functions BGA516 Package Variant Pin Configuration

Table 2-21 Port 34 Functions

Ball	Symbol	Ctrl.	Buffer Type	Function
AB16	P34.1	I	SLOW / PU1 / VEVR SB / ES5	<b>General-purpose input</b>
	GTM_TIM5_IN3_9			<b>Mux input channel 3 of TIM module 5</b>
	GTM_TIM3_IN4_12			<b>Mux input channel 4 of TIM module 3</b>
	GTM_TIM2_IN3_9			<b>Mux input channel 3 of TIM module 2</b>
	EVADC_G10CH11	AI		<b>Analog input channel 11, group 10</b>
	P34.1	O0		<b>General-purpose output</b>
	GTM_TOUT146	O1		<b>GTM muxed output</b>
	ASCLIN4_ATX	O2		<b>Transmit output</b>
	—	O3		<b>Reserved</b>
	CAN00_TXD	O4		<b>CAN transmit output node 0</b>
	IOM_MON2_5			<b>Monitor input 2</b>
	IOM_REF2_5			<b>Reference input 2</b>
	CAN20_TXD	O5		<b>CAN transmit output node 0</b>
	—	O6		<b>Reserved</b>
	CCU60_COUT63	O7		<b>T13 PWM channel 63</b>
	IOM_MON1_6		<b>Monitor input 1</b>	
IOM_REF1_0		<b>Reference input 1</b>		
AA17	P34.2	I	SLOW / PU1 / VEVR SB / ES	<b>General-purpose input</b>
	GTM_TIM5_IN4_9			<b>Mux input channel 4 of TIM module 5</b>
	GTM_TIM3_IN5_13			<b>Mux input channel 5 of TIM module 3</b>
	GTM_TIM2_IN4_8			<b>Mux input channel 4 of TIM module 2</b>
	ASCLIN4_ARXB			<b>Receive input</b>
	CAN00_RXDG			<b>CAN receive input node 0</b>
	CAN20_RXDC			<b>CAN receive input node 0</b>
	EVADC_G10CH10	AI		<b>Analog input channel 10, group 10</b>
	P34.2	O0		<b>General-purpose output</b>
	GTM_TOUT147	O1		<b>GTM muxed output</b>
	—	O2		<b>Reserved</b>
	—	O3		<b>Reserved</b>
	—	O4		<b>Reserved</b>
	—	O5		<b>Reserved</b>
	—	O6		<b>Reserved</b>
	CCU60_CC60	O7	<b>T12 PWM channel 60</b>	
IOM_MON1_2		<b>Monitor input 1</b>		
IOM_REF1_6		<b>Reference input 1</b>		

## Pin Definition and Functions BGA516 Package Variant Pin Configuration

Table 2-21 Port 34 Functions (cont'd)

Ball	Symbol	Ctrl.	Buffer Type	Function
AB17	P34.3	I	SLOW / PU1 / VEVRSB / ES	General-purpose input
	GTM_TIM5_IN5_10			Mux input channel 5 of TIM module 5
	GTM_TIM3_IN6_13			Mux input channel 6 of TIM module 3
	GTM_TIM2_IN5_9			Mux input channel 5 of TIM module 2
	EVADC_G10CH9	AI		Analog input channel 9, group 10
	P34.3	O0		General-purpose output
	GTM_TOUT148	O1		GTM muxed output
	ASCLIN4_ASCLK	O2		Shift clock output
	—	O3		Reserved
	QSPI2_SLSO10	O4		Master slave select output
	—	O5		Reserved
	—	O6		Reserved
	CCU60_COUT60	O7		T12 PWM channel 60
	IOM_MON1_3			Monitor input 1
IOM_REF1_3	Reference input 1			
AA18	P34.4	I	SLOW / PU1 / VEVRSB / ES	General-purpose input
	GTM_TIM5_IN6_10			Mux input channel 6 of TIM module 5
	GTM_TIM3_IN7_12			Mux input channel 7 of TIM module 3
	GTM_TIM2_IN6_8			Mux input channel 6 of TIM module 2
	QSPI2_MRSTD			Master SPI data input
	EVADC_G10CH8	AI		Analog input channel 8, group 10
	P34.4	O0		General-purpose output
	GTM_TOUT149	O1		GTM muxed output
	ASCLIN4_ASLSO	O2		Slave select signal output
	—	O3		Reserved
	QSPI2_MRST	O4		Slave SPI data output
	IOM_MON2_2			Monitor input 2
	IOM_REF2_2			Reference input 2
	—			O5
	—	O6		Reserved
	CCU60_CC61	O7		T12 PWM channel 61
	IOM_MON1_1			Monitor input 1
IOM_REF1_5	Reference input 1			

## Pin Definition and Functions BGA516 Package Variant Pin Configuration

Table 2-21 Port 34 Functions (cont'd)

Ball	Symbol	Ctrl.	Buffer Type	Function
AB18	P34.5	I	FAST / PU1 / VEVRSB / ES	General-purpose input
	GTM_TIM5_IN7_9			Mux input channel 7 of TIM module 5
	GTM_TIM4_IN7_12			Mux input channel 7 of TIM module 4
	GTM_TIM2_IN7_9			Mux input channel 7 of TIM module 2
	QSPI2_MTSRD			Slave SPI data input
	ASCLIN8_ARXE			Receive input
	P34.5			O0
	GTM_TOUT150	O1	GTM muxed output	
	ASCLIN8_ATX	O2	Transmit output	
	—	O3	Reserved	
	QSPI2_MTSR	O4	Master SPI data output	
	—	O5	Reserved	
	—	O6	Reserved	
	CCU60_COUT61	O7	T12 PWM channel 61	
	IOM_MON1_4		Monitor input 1	
IOM_REF1_2		Reference input 1		

Table 2-22 Analog Inputs

Ball	Symbol	Ctrl.	Buffer Type	Function
AA15	AN0	I	D / HighZ / VDDM	Analog Input 0
	EVADC_G0CH0			Analog input channel 0, group 0
	EDSADC_EDS3PA			Positive analog input channel 3, pin A
AB15	AN1	I	D / HighZ / VDDM	Analog Input 1
	EVADC_G0CH1			Analog input channel 1, group 0
	EDSADC_EDS3NA			Negative analog input channel 3, pin A
AD14	AN2	I	D / HighZ / VDDM	Analog Input 2
	EVADC_G0CH2			Analog input channel 2, group 0
	EDSADC_EDS0PA			Positive analog input channel 0, pin A
AB14	AN3	I	D / HighZ / VDDM	Analog Input 3
	EVADC_G0CH3			Analog input channel 3, group 0
	EDSADC_EDS0NA			Negative analog input channel 0, pin A
AA14	AN4	I	D / HighZ / VDDM	Analog Input 4
	EVADC_G11CH0			Analog input channel 0, group 11
	EVADC_G0CH4			Analog input channel 4, group 0
AE14	AN5	I	D / HighZ / VDDM	Analog Input 5
	EVADC_G11CH1			Analog input channel 1, group 11
	EVADC_G0CH5			Analog input channel 5, group 0

## Pin Definition and Functions BGA516 Package Variant Pin Configuration

Table 2-22 Analog Inputs (cont'd)

Ball	Symbol	Ctrl.	Buffer Type	Function
AA13	AN6	I	D / HighZ / VDDM	Analog Input 6
	EVADC_G11CH2			Analog input channel 2, group 11
	EVADC_G0CH6			Analog input channel 6, group 0
AB13	AN7	I	D / HighZ / VDDM	Analog Input 7
	EVADC_G11CH3			Analog input channel 3, group 11
	EVADC_G0CH7			Analog input channel 7, group 0
AD13	AN8	I	D / HighZ / VDDM	Analog Input 8
	EVADC_G11CH4			Analog input channel 4, group 11
	EVADC_G1CH0			Analog input channel 0, group 1
AB12	AN9	I	D / HighZ / VDDM	Analog Input 9
	EVADC_G11CH5			Analog input channel 5, group 11
	EVADC_G1CH1			Analog input channel 1, group 1
AE13	AN10	I	D / HighZ / VDDM	Analog Input 10
	EVADC_G11CH6			Analog input channel 6, group 11
	EVADC_G1CH2			Analog input channel 2, group 1
AD12	AN11	I	D / HighZ / VDDM	Analog Input 11
	EVADC_G11CH7			Analog input channel 7, group 11
	EVADC_G1CH3			Analog input channel 3, group 1
AA12	AN12	I	D / HighZ / VDDM	Analog Input 12
	EVADC_G1CH4			Analog input channel 4, group 1
	EDSADC_EDS0PB			Positive analog input channel 0, pin B
AD11	AN13	I	D / HighZ / VDDM	Analog Input 13
	EVADC_G1CH5			Analog input channel 5, group 1
	EDSADC_EDS0NB			Negative analog input channel 0, pin B
AB11	AN14	I	D / HighZ / VDDM	Analog Input 14
	EVADC_G1CH6			Analog input channel 6, group 1
	EDSADC_EDS3PB			Positive analog input channel 3, pin B
AA11	AN15	I	D / HighZ / VDDM	Analog Input 15
	EVADC_G1CH7			Analog input channel 7, group 1
	EDSADC_EDS3NB			Negative analog input channel 3, pin N
AD10	AN16	I	D / HighZ / VDDM	Analog Input 16
	EVADC_G2CH0			Analog input channel 0, group 2
	EVADC_FC0CH0			Analog input FC channel 0
AB10	AN17/P40.10	I	S / HighZ / VDDM	Analog Input 17
	SENT_SENT10A			Receive input channel 10
	EVADC_G2CH1			Analog input channel 1, group 2
	EVADC_FC1CH0			Analog input FC channel 1

## Pin Definition and Functions BGA516 Package Variant Pin Configuration

Table 2-22 Analog Inputs (cont'd)

Ball	Symbol	Ctrl.	Buffer Type	Function
AD9	AN18/P40.11	I	S / HighZ / VDDM	Analog Input 18
	SENT_SENT11A			Receive input channel 11
	EVADC_G11CH8			Analog input channel 8, group 11
	EVADC_G2CH2			Analog input channel 2, group 2
AD8	AN19/P40.12	I	S / HighZ / VDDM	Analog Input 19
	SENT_SENT12A			Receive input channel 12
	EVADC_G11CH9			Analog input channel 9, group 11
	EVADC_G2CH3			Analog input channel 3, group 2
AE8	AN20	I	D / HighZ / VDDM	Analog Input 20
	EVADC_G2CH4			Analog input channel 4, group 2
	EDSADC_EDS2PA			Positive analog input channel 2, pin A
AE7	AN21	I	D / HighZ / VDDM	Analog Input 21
	EVADC_G2CH5			Analog input channel 5, group 2
	EDSADC_EDS2NA			Negative analog input channel 2, pin A
AA10	AN22	I	D / HighZ / VDDM	Analog Input 22
	EVADC_G2CH6			Analog input channel 6, group 2
Y10	AN23	I	D / HighZ / VDDM	Analog Input 23
	EVADC_G2CH7			Analog input channel 7, group 2
AD7	AN24/P40.0	I	S / HighZ / VDDM	Analog Input 24
	SENT_SENT0A			Receive input channel 0
	EVADC_G3CH0			Analog input channel 0, group 3
	CCU60_CCPOS0D			Hall capture input 0
	EDSADC_EDS2PB			Positive analog input channel 2, pin B
AD6	AN25/P40.1	I	S / HighZ / VDDM	Analog Input 25
	SENT_SENT1A			Receive input channel 1
	EVADC_G3CH1			Analog input channel 1, group 3
	CCU60_CCPOS1B			Hall capture input 1
	EDSADC_EDS2NB			Negative analog input channel 2, pin B
AC7	AN26/P40.2	I	S / HighZ / VDDM	Analog Input 26
	SENT_SENT2A			Receive input channel 2
	EVADC_G3CH2			Analog input channel 2, group 3
	CCU60_CCPOS1D			Hall capture input 1
	EVADC_G11CH10			Analog input channel 10, group 11
AC6	AN27/P40.3	I	S / HighZ / VDDM	Analog Input 27
	SENT_SENT3A			Receive input channel 3
	EVADC_G3CH3			Analog input channel 3, group 3
	CCU60_CCPOS2B			Hall capture input 2
	EVADC_G11CH11			Analog input channel 11, group 11

## Pin Definition and Functions BGA516 Package Variant Pin Configuration

Table 2-22 Analog Inputs (cont'd)

Ball	Symbol	Ctrl.	Buffer Type	Function
AB7	AN28/P40.13	I	S / HighZ / VDDM	Analog Input 28
	SENT_SENT13A			Receive input channel 13
	EVADC_G3CH4			Analog input channel 4, group 3
	EVADC_G4CH4			Analog input channel 4, group 4
AB6	AN29/P40.14	I	S / HighZ / VDDM	Analog Input 29
	SENT_SENT14A			Receive input channel 14
	EVADC_G3CH5			Analog input channel 5, group 3
	EVADC_G4CH5			Analog input channel 5, group 4
AA9	AN30	I	D / HighZ / VDDM	Analog Input 30
	EVADC_G3CH6			Analog input channel 6, group 3
	EVADC_G4CH6			Analog input channel 6, group 4
Y9	AN31	I	D / HighZ / VDDM	Analog Input 31
	EVADC_G3CH7			Analog input channel 7, group 3
	EVADC_G4CH7			Analog input channel 7, group 4
W9	AN32/P40.4	I	S / HighZ / VDDM	Analog Input 32
	SENT_SENT4A			Receive input channel 4
	EVADC_G8CH0			Analog input channel 0, group 8
	CCU60_CCPOS2D			Hall capture input 2
	EVADC_G11CH12			Analog input channel 12, group 11
Y6	AN33/P40.5	I	S / HighZ / VDDM	Analog Input 33
	SENT_SENT5A			Receive input channel 5
	EVADC_G8CH1			Analog input channel 1, group 8
	CCU61_CCPOS0D			Hall capture input 0
	EVADC_G11CH13			Analog input channel 13, group 11
W10	AN34	I	D / HighZ / VDDM	Analog Input 34
	EVADC_G8CH2			Analog input channel 2, group 8
	EVADC_G11CH14			Analog input channel 14, group 11
Y7	AN35	I	D / HighZ / VDDM	Analog Input 35
	EVADC_G8CH3			Analog input channel 3, group 8
	EVADC_G11CH15			Analog input channel 15, group 11
V9	AN36/P40.6	I	S / HighZ / VDDM	Analog Input 36
	SENT_SENT6A			Receive input channel 6
	EVADC_G8CH4			Analog input channel 4, group 8
	CCU61_CCPOS1B			Hall capture input 1
	EDSADC_EDS1PA			Positive analog input channel 1, pin A

## Pin Definition and Functions BGA516 Package Variant Pin Configuration

Table 2-22 Analog Inputs (cont'd)

Ball	Symbol	Ctrl.	Buffer Type	Function
W7	AN37/P40.7	I	S / HighZ / VDDM	Analog Input 37
	SENT_SENT7A			Receive input channel 7
	EVADC_G8CH5			Analog input channel 5, group 8
	CCU61_CCPOS1D			Hall capture input 1
	EDSADC_EDS1NA			Negative analog input channel 1, pin A
V10	AN38/P40.8	I	S / HighZ / VDDM	Analog Input 38
	SENT_SENT8A			Receive input channel 8
	EVADC_G8CH6			Analog input channel 6, group 8
	CCU61_CCPOS2B			Hall capture input 2
	EDSADC_EDS1PB			Positive analog input channel 1, pin B
W6	AN39/P40.9	I	S / HighZ / VDDM	Analog Input 39
	SENT_SENT9A			Receive input channel 9
	EVADC_G8CH7			Analog input channel 7, group 8
	CCU61_CCPOS2D			Hall capture input 2
	EDSADC_EDS1NB			Negative analog input channel 1, pin B
U10	AN40	I	D / HighZ / VDDM	Analog Input 40
	EVADC_G8CH8			Analog input channel 8, group 8
	EVADC_G4CH0			Analog input channel 0, group 4
U9	AN41	I	D / HighZ / VDDM	Analog Input 41
	EVADC_G8CH9			Analog input channel 9, group 8
	EVADC_G4CH1			Analog input channel 1, group 4
T10	AN42	I	D / HighZ / VDDM	Analog Input 42
	EVADC_G8CH10			Analog input channel 10, group 8
	EVADC_G4CH2			Analog input channel 2, group 4
T9	AN43	I	D / HighZ / VDDM	Analog Input 43
	EVADC_G8CH11			Analog input channel 11, group 8
	EVADC_G4CH3			Analog input channel 3, group 4
V6	AN44	I	D / HighZ / VDDM	Analog Input 44
	EVADC_G8CH12			Analog input channel 12, group 8
	EDSADC_EDS1PC			Positive analog input channel 1, pin C
V7	AN45	I	D / HighZ / VDDM	Analog Input 45
	EVADC_G8CH13			Analog input channel 13, group 8
	EDSADC_EDS1NC			Negative analog input channel 1, pin C
U6	AN46	I	D / HighZ / VDDM	Analog Input 46
	EVADC_G8CH14			Analog input channel 14, group 8
	EDSADC_EDS1PD			Positive analog input channel 1, pin D

## Pin Definition and Functions BGA516 Package Variant Pin Configuration

Table 2-22 Analog Inputs (cont'd)

Ball	Symbol	Ctrl.	Buffer Type	Function
U7	AN47	I	D / HighZ / VDDM	Analog Input 47
	EVADC_G8CH15			Analog input channel 15, group 8
	EDSADC_EDS1ND			Negative analog input channel 1, pin D
AK7	AN48	I	D / HighZ / VDDM	Analog Input 48
	EVADC_G5CH0			Analog input channel 0, group 5
AJ7	AN49	I	D / HighZ / VDDM	Analog Input 49
	EVADC_G5CH1			Analog input channel 1, group 5
AJ6	AN50	I	D / HighZ / VDDM	Analog Input 50
	EVADC_G5CH2			Analog input channel 2, group 5
	EDSADC_EDS9PA			Positive analog input channel 9, pin A
AK6	AN51	I	D / HighZ / VDDM	Analog Input 51
	EVADC_G5CH3			Analog input channel 3, group 5
	EDSADC_EDS9NA			Negative analog input channel 9, pin A
AJ5	AN52	I	D / HighZ / VDDM	Analog Input 52
	EVADC_G5CH4			Analog input channel 4, group 5
	EDSADC_EDS6PA			Positive analog input channel 6, pin A
AK5	AN53	I	D / HighZ / VDDM	Analog Input 53
	EVADC_G5CH5			Analog input channel 5, group 5
	EDSADC_EDS6NA			Negative analog input channel 6, pin A
AJ4	AN54/P41.4	I	S / HighZ / VDDM	Analog Input 54
	SENT_SENT20A			Receive input channel 20
	EVADC_G5CH6			Analog input channel 6, group 5
	EDSADC_EDS6PB			Positive analog input channel 6, pin B
AK4	AN55/P41.5	I	S / HighZ / VDDM	Analog Input 55
	SENT_SENT21A			Receive input channel 21
	EVADC_G5CH7			Analog input channel 7, group 5
	EDSADC_EDS6NB			Negative analog input channel 6, pin B
AF1	AN56	I	D / HighZ / VDDM	Analog Input 56
	EVADC_G6CH0			Analog input channel 0, group 6
AF2	AN57	I	D / HighZ / VDDM	Analog Input 57
	EVADC_G6CH1			Analog input channel 1, group 6
AE2	AN58	I	D / HighZ / VDDM	Analog Input 58
	EVADC_G6CH2			Analog input channel 2, group 6
AE1	AN59	I	D / HighZ / VDDM	Analog Input 59
	EVADC_G6CH3			Analog input channel 3, group 6
AD1	AN60	I	D / HighZ / VDDM	Analog Input 60
	EVADC_G6CH4			Analog input channel 4, group 6
	EDSADC_EDS7PA			Positive analog input channel 7, pin A

## Pin Definition and Functions BGA516 Package Variant Pin Configuration

Table 2-22 Analog Inputs (cont'd)

Ball	Symbol	Ctrl.	Buffer Type	Function
AD2	AN61	I	D / HighZ / VDDM	Analog Input 61
	EVADC_G6CH5			Analog input channel 5, group 6
	EDSADC_EDS7NA			Negative analog input channel 7, pin A
AC2	AN62/P41.6	I	S / HighZ / VDDM	Analog Input 62
	SENT_SENT22A			Receive input channel 22
	EVADC_G6CH6			Analog input channel 6, group 6
	EDSADC_EDS7PB			Positive analog input channel 7, pin B
AC1	AN63/P41.7	I	S / HighZ / VDDM	Analog Input 63
	SENT_SENT23A			Receive input channel 23
	EVADC_G6CH7			Analog input channel 7, group 6
	EDSADC_EDS7NB			Negative analog input channel 7, pin B
AB2	AN64/P41.8	I	S / HighZ / VDDM	Analog Input 64
	SENT_SENT24A			Receive input channel 24
	EVADC_G7CH0			Analog input channel 0, group 7
AB1	AN65	I	D / HighZ / VDDM	Analog Input 65
	EVADC_G7CH1			Analog input channel 1, group 7
AA2	AN66	I	D / HighZ / VDDM	Analog Input 66
	EVADC_G7CH2			Analog input channel 2, group 7
AA1	AN67/P40.15	I	S / HighZ / VDDM	Analog Input 67
	SENT_SENT15A			Receive input channel 15
	EVADC_G7CH3			Analog input channel 3, group 7
Y1	AN68/P41.0	I	S / HighZ / VDDM	Analog Input 68
	SENT_SENT16A			Receive input channel 16
	EVADC_G7CH4			Analog input channel 4, group 7
	EDSADC_EDS8PA			Positive analog input channel 8, pin A
Y2	AN69/P41.1	I	S / HighZ / VDDM	Analog Input 69
	SENT_SENT17A			Receive input channel 17
	EVADC_G7CH5			Analog input channel 5, group 7
	EDSADC_EDS8NA			Negative analog input channel 8, pin A
W1	AN70/P41.2	I	S / HighZ / VDDM	Analog Input 70
	SENT_SENT18A			Receive input channel 18
	EVADC_G7CH6			Analog input channel 6, group 7
	EDSADC_EDS9PB			Positive analog input channel 9, pin B
W2	AN71/P41.3	I	S / HighZ / VDDM	Analog Input 71
	SENT_SENT19A			Receive input channel 19
	EVADC_G7CH7			Analog input channel 7, group 7
	EDSADC_EDS9NB			Negative analog input channel 9, pin B

## Pin Definition and Functions BGA516 Package Variant Pin Configuration

Note: Port Pins P32.0 and P32.1 are bidirectional pads and are having the following two functionalities implemented:

1. In case the pins are used as standard GPIOs the functions defined in the pin configuration tables of P32.0 and P32.1 are available.
2. In case the pins are used as pre-drivers for external MOSFETs (internal DCDC usecase) P32.0 and P32.1 act as analog IOs named VGATE1N and VGATE1P.

Table 2-23 System I/O

Ball	Symbol	Ctrl.	Buffer Type	Function
M21	$\overline{\text{ESR1}}$	I/O	FAST / PU1 / VEXT	<b>ESR1 Port Pin input - can be used to trigger a reset or an NMI</b> ESR1: External System Request Reset 1. Default NMI function. See also SCU chapter for details. Default after power-on can be different. See also SCU chapter 'Reset Control Unit' and SCU_IOCRR register description. PMS_EVRWUP: EVR Wakeup Pin
	PMS_ESR1WKP	I		<b>ESR1 pin input</b>
L21	$\overline{\text{ESR0}}$	I/O	FAST / OD / VEXT	<b>ESR0 Port Pin input - can be used to trigger a reset or an NMI</b> ESR0: External System Request Reset 0. Default configuration during and after reset is open-drain driver. The driver drives low during power-on reset. This is valid additionally after deactivation of PORST_N until the internal reset phase has finished. See also SCU chapter for details. Default after power-on can be different. See also SCU chapter 'Reset Control Unit' and SCU_IOCRR register description. PMS_EVRWUP: EVR Wakeup Pin
	PMS_ESR0WKP	I		<b>ESR0 pin input</b>
AD22	VGATE1P	O	—	<b>DCDC P ch. MOSFET gate driver output</b> P32.1 / External Pass Device gate control for EVRC
AE22	VGATE1N	O	—	<b>DCDC N ch. MOSFET gate driver output</b> P32.0 / SMPS mode: analog output. External Pass Device gate control for EVRC
U25	XTAL1	I	XTAL / VEXT	<b>XTAL pad1</b> XTAL1. Main Oscillator/PLL/Clock Generator Input.
U24	XTAL2	O	XTAL / VEXT	<b>XTAL pad2</b> XTAL2. Main Oscillator/PLL/Clock Generator OUTPUT
T24	$\overline{\text{TRST}}$	I	FAST / PU2 / VEXT	<b>JTAG Module Reset/Enable Input</b>
P21	TCK	I	FAST /	<b>JTAG Module Clock Input</b>
	DAP0	I	PD2 / VEXT	<b>DAP: DAP0 Clock Input</b>

## Pin Definition and Functions BGA516 Package Variant Pin Configuration

Table 2-23 System I/O (cont'd)

Ball	Symbol	Ctrl.	Buffer Type	Function
R21	TMS	I	FAST /	<b>JTAG Module State Machine Control Input</b>
	DAP1	I/O	PD2 / VEXT	<b>DAP: DAP1 Data I/O</b>
M22	$\overline{\text{PORST}}$	I/O	PORST / PD / VEXT	<b>PORST pin</b> Power On Reset Input. Additional strong PD in case of power fail.

Table 2-24 Supply

Ball	Symbol	Ctrl.	Buffer Type	Function
N19, V19, M18, W18, W13, V12, J21, K20, N12, M13	VDD	I	—	<b>Digital Core Power Supply (1.25V)</b>
AJ30, AH29, AD25, AC24, G8, F7, B3, A2, J29, J30, AH30, AK29, AK20, AJ11, AK11	VEXT	I	—	<b>External Power Supply (5V / 3.3V)</b>
J10	VFLEX	I	—	<b>Digital Power Supply for Flex Port Pads (5V / 3.3V)</b>
AE10, AJ9, AK9	VDDM	I	—	<b>ADC Analog Power Supply (5V / 3.3V)</b>
A29, B28, F24, G23	VDDP3	I	—	<b>Flash Power Supply (3.3V)</b>
AK30, AJ29, AE25, AD24, AB22, AA21, K10, J9, G7, B2, A30, B30, B29, F25, G24, J22, K21, H30, H29, AJ10, AK10	VSS	I	—	<b>Digital Ground</b>
AE9, AJ8, AK8	VSSM	I	—	<b>Analog Ground for VDDM</b>

## Pin Definition and Functions BGA516 Package Variant Pin Configuration

Table 2-24 Supply (cont'd)

Ball	Symbol	Ctrl.	Buffer Type	Function
P19, U19, P18, R18, T18, U18, M15, M16, M17, N17, R17, T17, V17, W17, N16, P16, R16, T16, U16, V16, N15, P15, R15, T15, U15, V15, M14, N14, R14, T14, V14, W14, P13, R13, T13, U13, P12, U12, T19, W15, W16, R12, T12	VSS	I	—	Digital Ground
T25	VSS	I	—	Oscillator Ground, VSS(OSC)
AE11	VAREF1	I	—	Positive Analog Reference Voltage 1
AE12	VAGND1	I	—	Negative Analog Reference Voltage 1
AA6	VAREF2	I	—	Positive Analog Reference Voltage 2
AA7	VAGND2	I	—	Negative Analog Reference Voltage 2

## Pin Definition and Functions BGA516 Package Variant Pin Configuration

Table 2-24 Supply (cont'd)

Ball	Symbol	Ctrl.	Buffer Type	Function
C30, D30, E30, F30, G30, W30, C29, D29, E29, F29, G29, A28, A27, B27, A26, B26, A25, A21, AJ20, B21, B20, A17, B17, A10, B10, A9, B9, A8, A4, B4, A3, AJ3, AK3, C2, D2, E2, H2, R2, AH2, AJ2, AK2, B1, C1, D1, E1, H1, J1, R1, T1, AH1, AJ1, B6, B14, B25, V1, V2, R19	NC	I	—	<b>Not connected. These pins are reserved for future extensions and shall not be connected externally</b>
AB9, F6, AE6, A1, AK1, V30, V29	NC1	I	—	<b>Not connected. These pins are not connected on package level and will not be used for future extensions</b>
AA16	VEVRSB	I	—	<b>Standby Power Supply (5V / 3.3V) for the Standby SRAM</b>
V24	VDD	I	—	<b>Digital Power Supply for Oscillator (1.25V), VDD(OSC)</b>
V25	VEXT	I	—	<b>Digital Power Supply for Oscillator (shall be supplied with same level as used for VEXT), VEXT(OSC)</b>
AG1	VAREF3	I	—	<b>Positive Analog Reference Voltage 3</b>
AG2	VAGND3	I	—	<b>Negative Analog Reference Voltage 3</b>

## 2.2 BGA292 Package Variant Pin Configuration

**Table 2-25 Port 00 Functions**

Ball	Symbol	Ctrl.	Buffer Type	Function
G1	P00.0	I	FAST / PU1 / VEXT / ES	General-purpose input
	GTM_TIM5_IN4_10			Mux input channel 4 of TIM module 5
	GTM_TIM3_IN0_1			Mux input channel 0 of TIM module 3
	GTM_TIM2_IN0_1			Mux input channel 0 of TIM module 2
	CCU61_CTRAPA			Trap input capture
	CCU60_T12HRE			External timer start 12
	MSC0_INJ0			Injection signal from port
	GETH_MDIOA			MDIO Input
	P00.0			O0
	GTM_TOUT9	O1	GTM muxed output	
	IOM_REF0_9		Reference input 0	
	ASCLIN3_ASCLK	O2	Shift clock output	
	ASCLIN3_ATX	O3	Transmit output	
	IOM_MON2_15		Monitor input 2	
	IOM_REF2_15		Reference input 2	
	—	O4	Reserved	
	CAN10_TXD	O5	CAN transmit output node 0	
	—	O6	Reserved	
	CCU60_COUT63	O7	T13 PWM channel 63	
	IOM_MON1_6		Monitor input 1	
IOM_REF1_0		Reference input 1		
GETH_MDIO	O	MDIO Output		

## Pin Definition and Functions BGA292 Package Variant Pin Configuration

Table 2-25 Port 00 Functions (cont'd)

Ball	Symbol	Ctrl.	Buffer Type	Function
G2	P00.1	I	SLOW / PU1 / VEXT / ES	General-purpose input
	GTM_TIM5_IN5_11			Mux input channel 5 of TIM module 5
	GTM_TIM3_IN1_1			Mux input channel 1 of TIM module 3
	GTM_TIM2_IN1_1			Mux input channel 1 of TIM module 2
	CCU60_CC60INB			T12 capture input 60
	ASCLIN3_ARXE			Receive input
	EDSADC_DSCIN5A			Modulator clock input, channel 5
	CAN10_RXDA			CAN receive input node 0
	PSI5_RX0A			RXD inputs (receive data) channel 0
	CCU61_CC60INA			T12 capture input 60
	SENT_SENT0B			Receive input channel 0
	EDSADC_DSCIN7B			Modulator clock input, channel 7
	EVADC_G9CH11			AI
	EDSADC_EDS5NA	Negative analog input channel 5, pin A		
	P00.1	O0	General-purpose output	
	GTM_TOUT10	O1	GTM muxed output	
	IOM_REF0_10		Reference input 0	
	ASCLIN3_ATX	O2	Transmit output	
	IOM_MON2_15		Monitor input 2	
	IOM_REF2_15		Reference input 2	
	—	O3	Reserved	
	EDSADC_DSCOUT5	O4	Modulator clock output	
	EDSADC_DSCOUT7	O5	Modulator clock output	
	SENT_SPC0	O6	Transmit output	
	CCU61_CC60	O7	T12 PWM channel 60	
	IOM_MON1_8		Monitor input 1	
IOM_REF1_13	Reference input 1			

## Pin Definition and Functions BGA292 Package Variant Pin Configuration

Table 2-25 Port 00 Functions (cont'd)

Ball	Symbol	Ctrl.	Buffer Type	Function
H1	P00.2	I	SLOW / PU1 / VEXT / ES1	General-purpose input
	GTM_TIM5_IN6_11			Mux input channel 6 of TIM module 5
	GTM_TIM3_IN1_2			Mux input channel 1 of TIM module 3
	GTM_TIM2_IN1_2			Mux input channel 1 of TIM module 2
	EDSADC_DSDIN7B			Digital datastream input, channel 7
	EDSADC_DSDIN5A			Digital datastream input, channel 5
	SENT_SENT1B			Receive input channel 1
	EVADC_G9CH10	AI	Analog input channel 10, group 9	
	EDSADC_EDS5PA		Positive analog input channel 5, pin A	
	P00.2	O0	General-purpose output	
	GTM_TOUT11	O1	GTM muxed output	
	IOM_REF0_11		Reference input 0	
	ASCLIN3_ASCLK	O2	Shift clock output	
	CAN21_TXD	O3	CAN transmit output node 1	
	PSI5_TX0	O4	TXD outputs (send data)	
	IOM_MON1_14		Monitor input 1	
	IOM_REF1_14		Reference input 1	
	CAN03_TXD		O5	CAN transmit output node 3
	IOM_MON2_8		Monitor input 2	
	IOM_REF2_8		Reference input 2	
	QSPI3_SLSO4	O6	Master slave select output	
	CCU61_COUT60	O7	T12 PWM channel 60	
	IOM_MON1_11		Monitor input 1	
	IOM_REF1_10		Reference input 1	

## Pin Definition and Functions BGA292 Package Variant Pin Configuration

Table 2-25 Port 00 Functions (cont'd)

Ball	Symbol	Ctrl.	Buffer Type	Function
H2	P00.3	I	SLOW / PU1 / VEXT / ES1	General-purpose input
	GTM_TIM5_IN7_10			Mux input channel 7 of TIM module 5
	GTM_TIM3_IN2_1			Mux input channel 2 of TIM module 3
	GTM_TIM2_IN2_1			Mux input channel 2 of TIM module 2
	CCU60_CC61INB			T12 capture input 61
	EDSADC_DSCIN3A			Modulator clock input, channel 3
	EDSADC_ITR5F			Trigger/Gate input, channel 5
	PSI5_RX1A			RXD inputs (receive data) channel 1
	CAN03_RXDA			CAN receive input node 3
	CAN21_RXDA			CAN receive input node 1
	PSI5S_RXA			RX data input
	SENT_SENT2B			Receive input channel 2
	CCU61_CC61INA			T12 capture input 61
	ASCLIN12_ARXA			Receive input
	EVADC_G9CH9	AI	Analog input channel 9, group 9	
	EDSADC_EDS5NB		Negative analog input channel 5, pin B	
	P00.3	O0	General-purpose output	
	GTM_TOUT12	O1	GTM muxed output	
	IOM_REF0_12		Reference input 0	
	ASCLIN3_ASLSO	O2	Slave select signal output	
ASCLIN12_ATX	O3	Transmit output		
EDSADC_DSCOUT3	O4	Modulator clock output		
—	O5	Reserved		
SENT_SPC2	O6	Transmit output		
CCU61_CC61	O7	T12 PWM channel 61		
IOM_MON1_9		Monitor input 1		
IOM_REF1_12		Reference input 1		

## Pin Definition and Functions BGA292 Package Variant Pin Configuration

Table 2-25 Port 00 Functions (cont'd)

Ball	Symbol	Ctrl.	Buffer Type	Function	
J1	P00.4	I	SLOW / PU1 / VEXT / ES1	General-purpose input	
	GTM_TIM6_IN4_1			Mux input channel 4 of TIM module 6	
	GTM_TIM3_IN3_1			Mux input channel 3 of TIM module 3	
	GTM_TIM2_IN3_1			Mux input channel 3 of TIM module 2	
	SCU_E_REQ2_2			ERU Channel 2 inputs 0 to 5 (0 is the LSB and 5 is the MSB)	
	SENT_SENT3B			Receive input channel 3	
	EDSADC_DSDIN3A			Digital datastream input, channel 3	
	EDSADC_SGNA			Carrier sign signal input	
	ASCLIN10_ARXA			Receive input	
	GTM_DTMA5_0			CDTM5_DTM4	
	GTM_DTMT3_0			CDTM3_DTM0	
	EVADC_G9CH8			AI	Analog input channel 8, group 9
	EDSADC_EDS5PB				Positive analog input channel 5, pin B
	P00.4			O0	General-purpose output
	GTM_TOUT13	O1	GTM muxed output		
	IOM_REF0_13		Reference input 0		
	PSI5S_TX	O2	TX data output		
	CAN11_TXD	O3	CAN transmit output node 1		
	PSI5_TX1	O4	TXD outputs (send data)		
	IOM_MON1_15		Monitor input 1		
	—	O5	Reserved		
	SENT_SPC3	O6	Transmit output		
	CCU61_COUT61	O7	T12 PWM channel 61		
	IOM_MON1_12		Monitor input 1		
IOM_REF1_9		Reference input 1			

## Pin Definition and Functions BGA292 Package Variant Pin Configuration

Table 2-25 Port 00 Functions (cont'd)

Ball	Symbol	Ctrl.	Buffer Type	Function
J2	P00.5	I	SLOW / PU1 / VEXT / ES1	General-purpose input
	GTM_TIM3_IN4_1			Mux input channel 4 of TIM module 3
	GTM_TIM3_IN0_11			Mux input channel 0 of TIM module 3
	GTM_TIM2_IN4_1			Mux input channel 4 of TIM module 2
	CCU60_CC62INB			T12 capture input 62
	EDSADC_DSCIN2A			Modulator clock input, channel 2
	PSI5_RX2A			RXD inputs (receive data) channel 2
	CCU61_CC62INA			T12 capture input 62
	SENT_SENT4B			Receive input channel 4
	CAN11_RXDB			CAN receive input node 1
	ASCLIN12_ARXB			Receive input
	GTM_DTMT1_1			CDTM1_DTM0
	EVADC_G9CH7			AI
	P00.5	O0	General-purpose output	
	GTM_TOUT14	O1	GTM muxed output	
	IOM_REF0_14		Reference input 0	
	EDSADC_CGPWMN	O2	Negative carrier generator output	
	QSPI3_SLSO3	O3	Master slave select output	
	EDSADC_DSCOUT2	O4	Modulator clock output	
	EVADC_FC0BFLOUT	O5	Boundary flag output, FC channel 0	
SENT_SPC4	O6	Transmit output		
CCU61_CC62	O7	T12 PWM channel 62		
IOM_MON1_10		Monitor input 1		
IOM_REF1_11		Reference input 1		

## Pin Definition and Functions BGA292 Package Variant Pin Configuration

Table 2-25 Port 00 Functions (cont'd)

Ball	Symbol	Ctrl.	Buffer Type	Function
J4	P00.6	I	SLOW / PU1 / VEXT / ES1	General-purpose input
	GTM_TIM3_IN5_1			Mux input channel 5 of TIM module 3
	GTM_TIM3_IN1_14			Mux input channel 1 of TIM module 3
	GTM_TIM2_IN5_1			Mux input channel 5 of TIM module 2
	EDSADC_ITR4F			Trigger/Gate input, channel 4
	EDSADC_DSDIN2A			Digital datastream input, channel 2
	SENT_SENT5B			Receive input channel 5
	ASCLIN5_ARXA			Receive input
	GTM_DTMT3_1			CDTM3_DTM0
	EVADC_G9CH6			AI
	P00.6	O0	General-purpose output	
	GTM_TOUT15	O1	GTM muxed output	
	IOM_REF0_15		Reference input 0	
	EDSADC_CGPWMP	O2	Positive carrier generator output	
	—	O3	Reserved	
	PSI5_TX2	O4	TXD outputs (send data)	
	IOM_REF1_15		Reference input 1	
	EVADC_EMUX10	O5	Control of external analog multiplexer interface 1	
	SENT_SPC5	O6	Transmit output	
	CCU61_COUT62	O7	T12 PWM channel 62	
IOM_MON1_13		Monitor input 1		
IOM_REF1_8		Reference input 1		

## Pin Definition and Functions BGA292 Package Variant Pin Configuration

Table 2-25 Port 00 Functions (cont'd)

Ball	Symbol	Ctrl.	Buffer Type	Function
K1	P00.7	I	SLOW / PU1 / VEXT / ES1	General-purpose input
	GTM_TIM3_IN6_1			Mux input channel 6 of TIM module 3
	GTM_TIM3_IN2_11			Mux input channel 2 of TIM module 3
	GTM_TIM2_IN6_1			Mux input channel 6 of TIM module 2
	CCU61_CC60INC			T12 capture input 60
	SENT_SENT6B			Receive input channel 6
	EDSADC_DSCIN4A			Modulator clock input, channel 4
	GPT120_T2INA			Trigger/gate input of timer T2
	CCU61_CCPOS0A			Hall capture input 0
	CCU60_T12HRB			External timer start 12
	GTM_DTMT0_2			CDTM0_DTM0
	EVADC_G9CH5			AI
	EDSADC_EDS4NA		Negative analog input channel 4, pin A	
	P00.7	O0	General-purpose output	
	GTM_TOUT16	O1	GTM muxed output	
	ASCLIN5_ATX	O2	Transmit output	
	EVADC_FC2BFLOUT	O3	Boundary flag output, FC channel 2	
	EDSADC_DSCOUT4	O4	Modulator clock output	
	EVADC_EMUX11	O5	Control of external analog multiplexer interface 1	
	SENT_SPC6	O6	Transmit output	
CCU61_CC60	O7	T12 PWM channel 60		
IOM_MON1_8		Monitor input 1		
IOM_REF1_13		Reference input 1		

## Pin Definition and Functions BGA292 Package Variant Pin Configuration

Table 2-25 Port 00 Functions (cont'd)

Ball	Symbol	Ctrl.	Buffer Type	Function	
K4	P00.8	I	SLOW / PU1 / VEXT / ES1	General-purpose input	
	GTM_TIM3_IN7_1			Mux input channel 7 of TIM module 3	
	GTM_TIM3_IN3_11			Mux input channel 3 of TIM module 3	
	GTM_TIM2_IN7_1			Mux input channel 7 of TIM module 2	
	CCU61_CC61INC			T12 capture input 61	
	SENT_SENT7B			Receive input channel 7	
	EDSADC_DSDIN4A			Digital datastream input, channel 4	
	GPT120_T2EUDA			Count direction control input of timer T2	
	CCU61_CCPOS1A			Hall capture input 1	
	CCU60_T13HRB			External timer start 13	
	ASCLIN10_ARXB			Receive input	
	EVADC_G9CH4			AI	Analog input channel 4, group 9
	EDSADC_EDS4PA				Positive analog input channel 4, pin A
	P00.8	O0	General-purpose output		
	GTM_TOUT17	O1	GTM muxed output		
	QSPI3_SLSO6	O2	Master slave select output		
	ASCLIN10_ATX	O3	Transmit output		
	—	O4	Reserved		
	EVADC_EMUX12	O5	Control of external analog multiplexer interface 1		
	SENT_SPC7	O6	Transmit output		
CCU61_CC61	O7	T12 PWM channel 61			
IOM_MON1_9		Monitor input 1			
IOM_REF1_12		Reference input 1			

## Pin Definition and Functions BGA292 Package Variant Pin Configuration

Table 2-25 Port 00 Functions (cont'd)

Ball	Symbol	Ctrl.	Buffer Type	Function	
K2	P00.9	I	SLOW / PU1 / VEXT / ES1	General-purpose input	
	GTM_TIM4_IN0_7			Mux input channel 0 of TIM module 4	
	GTM_TIM1_IN0_1			Mux input channel 0 of TIM module 1	
	GTM_TIM0_IN0_1			Mux input channel 0 of TIM module 0	
	CCU61_CC62INC			T12 capture input 62	
	SENT_SENT8B			Receive input channel 8	
	CCU61_CCPOS2A			Hall capture input 2	
	EDSADC_DSCIN1A			Modulator clock input, channel 1	
	EDSADC_ITR3F			Trigger/Gate input, channel 3	
	GPT120_T4EUDA			Count direction control input of timer T4	
	CCU60_T13HRC			External timer start 13	
	CCU60_T12HRC			External timer start 12	
	ASCLIN13_ARXA			Receive input	
	EVADC_G9CH3			AI	Analog input channel 3, group 9
	EDSADC_EDS4NB				Negative analog input channel 4, pin B
	P00.9	O0	General-purpose output		
	GTM_TOUT18	O1	GTM muxed output		
	QSPI3_SLSO7	O2	Master slave select output		
	ASCLIN3_ARTS	O3	Ready to send output		
	EDSADC_DSCOUT1	O4	Modulator clock output		
	ASCLIN4_ATX	O5	Transmit output		
	SENT_SPC8	O6	Transmit output		
	CCU61_CC62	O7	T12 PWM channel 62		
IOM_MON1_10		Monitor input 1			
IOM_REF1_11		Reference input 1			

## Pin Definition and Functions BGA292 Package Variant Pin Configuration

Table 2-25 Port 00 Functions (cont'd)

Ball	Symbol	Ctrl.	Buffer Type	Function
K5	P00.10	I	SLOW / PU1 / VEXT / ES1	General-purpose input
	GTM_TIM4_IN1_11			Mux input channel 1 of TIM module 4
	GTM_TIM1_IN1_1			Mux input channel 1 of TIM module 1
	GTM_TIM0_IN1_1			Mux input channel 1 of TIM module 0
	SENT_SENT9B			Receive input channel 9
	EDSADC_DSDIN1A			Digital datastream input, channel 1
	EVADC_G9CH2			Analog input channel 2, group 9
	EDSADC_EDS4PB	AI	Positive analog input channel 4, pin B	
	P00.10	O0	General-purpose output	
	GTM_TOUT19	O1	GTM muxed output	
	ASCLIN4_ASCLK	O2	Shift clock output	
	ASCLIN13_ATX	O3	Transmit output	
	—	O4	Reserved	
	—	O5	Reserved	
	SENT_SPC9	O6	Transmit output	
	CCU61_COUT63	O7	T13 PWM channel 63	
	IOM_MON1_7		Monitor input 1	
IOM_REF1_7		Reference input 1		
L1	P00.11	I	SLOW / PU1 / VEXT / ES1	General-purpose input
	GTM_TIM4_IN2_11			Mux input channel 2 of TIM module 4
	GTM_TIM1_IN2_1			Mux input channel 2 of TIM module 1
	GTM_TIM0_IN2_1			Mux input channel 2 of TIM module 0
	CCU60_CTRAPA			Trap input capture
	EDSADC_DSCIN0A			Modulator clock input, channel 0
	CCU61_T12HRE			External timer start 12
	SENT_SENT10B	Receive input channel 10		
	ASCLIN13_ARXB	Receive input		
	EVADC_G9CH1	AI	Analog input channel 1, group 9	
	EVADC_FC3CH0		Analog input FC channel 3	
	P00.11	O0	General-purpose output	
	GTM_TOUT20	O1	GTM muxed output	
	ASCLIN4_ASLSO	O2	Slave select signal output	
	ASCLIN13_ATX	O3	Transmit output	
	EDSADC_DSCOUT0	O4	Modulator clock output	
	—	O5	Reserved	
—	O6	Reserved		
—	O7	Reserved		

## Pin Definition and Functions BGA292 Package Variant Pin Configuration

Table 2-25 Port 00 Functions (cont'd)

Ball	Symbol	Ctrl.	Buffer Type	Function
L2	P00.12	I	SLOW / PU1 / VEXT / ES1	General-purpose input
	GTM_TIM4_IN3_11			Mux input channel 3 of TIM module 4
	GTM_TIM1_IN3_1			Mux input channel 3 of TIM module 1
	GTM_TIM0_IN3_1			Mux input channel 3 of TIM module 0
	ASCLIN3_ACTSA			Clear to send input
	EDSADC_DSDIN0A			Digital datastream input, channel 0
	ASCLIN4_ARXA			Receive input
	SENT_SENT11B			Receive input channel 11
	EVADC_G9CH0			AI
	EVADC_FC2CH0	Analog input FC channel 2		
	P00.12	O0	General-purpose output	
	GTM_TOUT21	O1	GTM muxed output	
	—	O2	Reserved	
	—	O3	Reserved	
	—	O4	Reserved	
	—	O5	Reserved	
	—	O6	Reserved	
	CCU61_COUT63	O7	T13 PWM channel 63	
	IOM_MON1_7		Monitor input 1	
	IOM_REF1_7		Reference input 1	

## Pin Definition and Functions BGA292 Package Variant Pin Configuration

Table 2-26 Port 01 Functions

Ball	Symbol	Ctrl.	Buffer Type	Function
G5	P01.3	I	SLOW / PU1 / VEXT / ES	General-purpose input
	GTM_TIM4_IN5_2			Mux input channel 5 of TIM module 4
	GTM_TIM2_IN0_14			Mux input channel 0 of TIM module 2
	GTM_TIM0_IN5_8			Mux input channel 5 of TIM module 0
	QSPI3_SLSIB			Slave select input
	EDSADC_ITR7F			Trigger/Gate input, channel 7
	EVADC_G9CH14	AI	Analog input channel 14, group 9	
	P01.3	O0	General-purpose output	
	GTM_TOUT111	O1	GTM muxed output	
	—	O2	Reserved	
	—	O3	Reserved	
	QSPI3_SLSO9	O4	Master slave select output	
	CAN01_TXD	O5	CAN transmit output node 1	
	IOM_MON2_6		Monitor input 2	
	IOM_REF2_6		Reference input 2	
	—	O6	Reserved	
	—	O7	Reserved	
G4	P01.4	I	SLOW / PU1 / VEXT / ES	General-purpose input
	GTM_TIM4_IN6_2			Mux input channel 6 of TIM module 4
	GTM_TIM2_IN1_14			Mux input channel 1 of TIM module 2
	GTM_TIM0_IN6_8			Mux input channel 6 of TIM module 0
	CAN01_RXDC			CAN receive input node 1
	EDSADC_ITR7E			Trigger/Gate input, channel 7
	EVADC_G9CH13	AI	Analog input channel 13, group 9	
	P01.4	O0	General-purpose output	
	GTM_TOUT112	O1	GTM muxed output	
	—	O2	Reserved	
	ASCLIN9_ASLSO	O3	Slave select signal output	
	QSPI3_SLSO10	O4	Master slave select output	
	—	O5	Reserved	
	—	O6	Reserved	
	—	O7	Reserved	

## Pin Definition and Functions BGA292 Package Variant Pin Configuration

Table 2-26 Port 01 Functions (cont'd)

Ball	Symbol	Ctrl.	Buffer Type	Function
H5	P01.5	I	SLOW / PU1 / VEXT / ES	General-purpose input
	GTM_TIM5_IN3_2			Mux input channel 3 of TIM module 5
	GTM_TIM2_IN3_7			Mux input channel 3 of TIM module 2
	GTM_TIM2_IN2_7			Mux input channel 2 of TIM module 2
	QSPI3_MRSTC			Master SPI data input
	EDSADC_DSCIN8A			Modulator clock input, channel 8
	ASCLIN9_ARXA			Receive input
	EVADC_G9CH12	AI	Analog input channel 12, group 9	
	P01.5	O0	General-purpose output	
	GTM_TOUT113	O1	GTM muxed output	
	—	O2	Reserved	
	—	O3	Reserved	
	QSPI3_MRST	O4	Slave SPI data output	
	IOM_MON2_3		Monitor input 2	
	IOM_REF2_3		Reference input 2	
	—	O5	Reserved	
	EDSADC_DSCOUT8	O6	Modulator clock output	
—	O7	Reserved		
H4	P01.6	I	FAST / PU1 / VEXT / ES	General-purpose input
	GTM_TIM5_IN6_2			Mux input channel 6 of TIM module 5
	GTM_TIM5_IN5_3			Mux input channel 5 of TIM module 5
	GTM_TIM2_IN5_7			Mux input channel 5 of TIM module 2
	QSPI3_MTSRC			Slave SPI data input
	EDSADC_DSDIN8A			Digital datastream input, channel 8
	P01.6	O0	General-purpose output	
	GTM_TOUT114	O1	GTM muxed output	
	ASCLIN12_ATX	O2	Transmit output	
	ASCLIN9_ASCLK	O3	Shift clock output	
	QSPI3_MTSR	O4	Master SPI data output	
	—	O5	Reserved	
	—	O6	Reserved	
	—	O7	Reserved	

## Pin Definition and Functions BGA292 Package Variant Pin Configuration

Table 2-26 Port 01 Functions (cont'd)

Ball	Symbol	Ctrl.	Buffer Type	Function
J5	P01.7	I	FAST / PU1 / VEXT / ES	<b>General-purpose input</b>
	GTM_TIM5_IN7_2			<b>Mux input channel 7 of TIM module 5</b>
	GTM_TIM2_IN7_7			<b>Mux input channel 7 of TIM module 2</b>
	QSPI3_SCLKC			<b>Slave SPI clock inputs</b>
	EDSADC_ITR8F			<b>Trigger/Gate input, channel 8</b>
	ASCLIN9_ARXB			<b>Receive input</b>
	P01.7	O0		<b>General-purpose output</b>
	GTM_TOUT115	O1		<b>GTM muxed output</b>
	—	O2		<b>Reserved</b>
	ASCLIN9_ATX	O3		<b>Transmit output</b>
	QSPI3_SCLK	O4		<b>Master SPI clock output</b>
	—	O5		<b>Reserved</b>
	—	O6		<b>Reserved</b>
	—	O7		<b>Reserved</b>

## Pin Definition and Functions BGA292 Package Variant Pin Configuration

Table 2-27 Port 02 Functions

Ball	Symbol	Ctrl.	Buffer Type	Function	
B1	P02.0	I	FAST / PU1 / VEXT / ES	<b>General-purpose input</b>	
	GTM_TIM1_IN0_2			<b>Mux input channel 0 of TIM module 1</b>	
	GTM_TIM0_IN0_2			<b>Mux input channel 0 of TIM module 0</b>	
	CCU61_CC60INB			<b>T12 capture input 60</b>	
	ASCLIN2_ARXG			<b>Receive input</b>	
	CCU60_CC60INA			<b>T12 capture input 60</b>	
	SCU_E_REQ3_2			<b>ERU Channel 3 inputs 0 to 5 (0 is the LSB and 5 is the MSB)</b>	
	GTM_DTMA0_0			<b>CDTM0_DTM4</b>	
	P02.0			O0	<b>General-purpose output</b>
	GTM_TOUT0			O1	<b>GTM muxed output</b>
	IOM_REF0_0		<b>Reference input 0</b>		
	ASCLIN2_ATX	O2	<b>Transmit output</b>		
	IOM_MON2_14		<b>Monitor input 2</b>		
	IOM_REF2_14		<b>Reference input 2</b>		
	QSPI3_SLSO1	O3	<b>Master slave select output</b>		
	EDSADC_CGPWMN	O4	<b>Negative carrier generator output</b>		
	CAN00_TXD	O5	<b>CAN transmit output node 0</b>		
	IOM_MON2_5		<b>Monitor input 2</b>		
	IOM_REF2_5		<b>Reference input 2</b>		
	ERAY0_TXDA	O6	<b>Transmit Channel A</b>		
CCU60_CC60	O7	<b>T12 PWM channel 60</b>			
IOM_MON1_2		<b>Monitor input 1</b>			
IOM_REF1_6		<b>Reference input 1</b>			

## Pin Definition and Functions BGA292 Package Variant Pin Configuration

Table 2-27 Port 02 Functions (cont'd)

Ball	Symbol	Ctrl.	Buffer Type	Function
C2	P02.1	I	SLOW / PU1 / VEXT / ES	General-purpose input
	GTM_TIM1_IN1_2			Mux input channel 1 of TIM module 1
	GTM_TIM0_IN1_2			Mux input channel 1 of TIM module 0
	ERAY0_RXDA2			Receive Channel A2
	ASCLIN2_ARXB			Receive input
	CAN00_RXDA			CAN receive input node 0
	SCU_E_REQ2_1			ERU Channel 2 inputs 0 to 5 (0 is the LSB and 5 is the MSB)
	P02.1	O0	General-purpose output	
	GTM_TOUT1	O1	GTM muxed output	
	IOM_REF0_1		Reference input 0	
	QSPI4_SLSO7	O2	Master slave select output	
	QSPI3_SLSO2	O3	Master slave select output	
	EDSADC_CGPWMP	O4	Positive carrier generator output	
	—	O5	Reserved	
	—	O6	Reserved	
	CCU60_COUT60	O7	T12 PWM channel 60	
	IOM_MON1_3		Monitor input 1	
	IOM_REF1_3		Reference input 1	

## Pin Definition and Functions BGA292 Package Variant Pin Configuration

Table 2-27 Port 02 Functions (cont'd)

Ball	Symbol	Ctrl.	Buffer Type	Function
C1	P02.2	I	FAST / PU1 / VEXT / ES	General-purpose input
	GTM_TIM1_IN2_2			Mux input channel 2 of TIM module 1
	GTM_TIM0_IN2_2			Mux input channel 2 of TIM module 0
	CCU61_CC61INB			T12 capture input 61
	CCU60_CC61INA			T12 capture input 61
	SENT_SENT14B			Receive input channel 14
	P02.2			O0
	GTM_TOUT2	O1	GTM muxed output	
	IOM_REF0_2		Reference input 0	
	ASCLIN1_ATX	O2	Transmit output	
	IOM_MON2_13		Monitor input 2	
	IOM_REF2_13		Reference input 2	
	QSPI3_SLSO3	O3	Master slave select output	
	PSI5_TX0	O4	TXD outputs (send data)	
	IOM_MON1_14		Monitor input 1	
	IOM_REF1_14		Reference input 1	
	CAN02_TXD	O5	CAN transmit output node 2	
	IOM_MON2_7		Monitor input 2	
	IOM_REF2_7		Reference input 2	
	ERAY0_TXDB	O6	Transmit Channel B	
	CCU60_CC61	O7	T12 PWM channel 61	
	IOM_MON1_1		Monitor input 1	
	IOM_REF1_5		Reference input 1	

## Pin Definition and Functions BGA292 Package Variant Pin Configuration

Table 2-27 Port 02 Functions (cont'd)

Ball	Symbol	Ctrl.	Buffer Type	Function
D2	P02.3	I	SLOW / PU1 / VEXT / ES	General-purpose input
	GTM_TIM1_IN3_2			Mux input channel 3 of TIM module 1
	GTM_TIM0_IN3_2			Mux input channel 3 of TIM module 0
	EDSADC_DSCIN5B			Modulator clock input, channel 5
	ERAY0_RXDB2			Receive Channel B2
	CAN02_RXDB			CAN receive input node 2
	ASCLIN1_ARXG			Receive input
	MSC1_SD11			Upstream asynchronous input signal
	PSI5_RX0B			RXD inputs (receive data) channel 0
	SENT_SENT13B			Receive input channel 13
	P02.3			O0
	GTM_TOUT3	O1	GTM muxed output	
	IOM_REF0_3		Reference input 0	
	ASCLIN2_ASLSO	O2	Slave select signal output	
	QSPI3_SLSO4	O3	Master slave select output	
	EDSADC_DSCOUT5	O4	Modulator clock output	
	—	O5	Reserved	
	—	O6	Reserved	
	CCU60_COUT61	O7	T12 PWM channel 61	
	IOM_MON1_4		Monitor input 1	
IOM_REF1_2		Reference input 1		

## Pin Definition and Functions BGA292 Package Variant Pin Configuration

Table 2-27 Port 02 Functions (cont'd)

Ball	Symbol	Ctrl.	Buffer Type	Function	
D1	P02.4	I	FAST / PU1 / VEXT / ES	General-purpose input	
	GTM_TIM1_IN4_1			Mux input channel 4 of TIM module 1	
	GTM_TIM0_IN4_1			Mux input channel 4 of TIM module 0	
	CCU61_CC62INB			T12 capture input 62	
	EDSADC_DSDIN5B			Digital datastream input, channel 5	
	QSPI3_SLSIA			Slave select input	
	CCU60_CC62INA			T12 capture input 62	
	I2C0_SDAA			Serial Data Input 0	
	CAN11_RXDA			CAN receive input node 1	
	CAN0_ECTT1			External CAN time trigger input	
	SENT_SENT12B			Receive input channel 12	
	P02.4			O0	General-purpose output
	GTM_TOUT4			O1	GTM muxed output
	IOM_REF0_4		Reference input 0		
	ASCLIN2_ASCLK	O2	Shift clock output		
	QSPI3_SLSO0	O3	Master slave select output		
	PSI5S_CLK	O4	PSI5S CLK is a clock that can be used on a pin to drive the external PHY.		
	I2C0_SDA	O5	Serial Data Output		
	ERAY0_TXENA	O6	Transmit Enable Channel A		
	CCU60_CC62	O7	T12 PWM channel 62		
IOM_MON1_0		Monitor input 1			
IOM_REF1_4		Reference input 1			

## Pin Definition and Functions BGA292 Package Variant Pin Configuration

Table 2-27 Port 02 Functions (cont'd)

Ball	Symbol	Ctrl.	Buffer Type	Function	
E2	P02.5	I	FAST / PU1 / VEXT / ES	General-purpose input	
	GTM_TIM1_IN5_1			Mux input channel 5 of TIM module 1	
	GTM_TIM0_IN5_1			Mux input channel 5 of TIM module 0	
	EDSADC_DSCIN4B			Modulator clock input, channel 4	
	I2C0_SCLA			Serial Clock Input 0	
	PSI5_RX1B			RXD inputs (receive data) channel 1	
	PSI5S_RXB			RX data input	
	QSPI3_MRSTA			Master SPI data input	
	SENT_SENT3C			Receive input channel 3	
	CAN0_ECTT2			External CAN time trigger input	
	P02.5			O0	General-purpose output
	GTM_TOUT5			O1	GTM muxed output
	IOM_REF0_5		Reference input 0		
	CAN11_TXD	O2	CAN transmit output node 1		
	QSPI3_MRST	O3	Slave SPI data output		
	IOM_MON2_3		Monitor input 2		
	IOM_REF2_3		Reference input 2		
	EDSADC_DSCOUT4	O4	Modulator clock output		
	I2C0_SCL	O5	Serial Clock Output		
	ERAY0_TXENB	O6	Transmit Enable Channel B		
CCU60_COUT62	O7	T12 PWM channel 62			
IOM_MON1_5		Monitor input 1			
IOM_REF1_1		Reference input 1			

## Pin Definition and Functions BGA292 Package Variant Pin Configuration

Table 2-27 Port 02 Functions (cont'd)

Ball	Symbol	Ctrl.	Buffer Type	Function
E1	P02.6	I	FAST / PU1 / VEXT / ES	General-purpose input
	GTM_TIM3_IN0_10			Mux input channel 0 of TIM module 3
	GTM_TIM1_IN6_1			Mux input channel 6 of TIM module 1
	GTM_TIM0_IN6_1			Mux input channel 6 of TIM module 0
	CCU60_CC60INC			T12 capture input 60
	SENT_SENT2C			Receive input channel 2
	EDSADC_DSDIN4B			Digital datastream input, channel 4
	EDSADC_ITR5E			Trigger/Gate input, channel 5
	GPT120_T3INA			Trigger/gate input of core timer T3
	CCU60_CCPOS0A			Hall capture input 0
	CCU61_T12HRB			External timer start 12
	QSPI3_MTSRA			Slave SPI data input
	P02.6			O0
	GTM_TOUT6	O1	GTM muxed output	
	IOM_REF0_6		Reference input 0	
	PSI5S_TX	O2	TX data output	
	QSPI3_MTSR	O3	Master SPI data output	
	PSI5_TX1	O4	TXD outputs (send data)	
	IOM_MON1_15		Monitor input 1	
	EVADC_EMUX00	O5	Control of external analog multiplexer interface 0	
—	O6	Reserved		
CCU60_CC60	O7	T12 PWM channel 60		
IOM_MON1_2		Monitor input 1		
IOM_REF1_6		Reference input 1		

## Pin Definition and Functions BGA292 Package Variant Pin Configuration

Table 2-27 Port 02 Functions (cont'd)

Ball	Symbol	Ctrl.	Buffer Type	Function
F2	P02.7	I	FAST / PU1 / VEXT / ES	General-purpose input
	GTM_TIM3_IN1_10			Mux input channel 1 of TIM module 3
	GTM_TIM1_IN7_1			Mux input channel 7 of TIM module 1
	GTM_TIM0_IN7_1			Mux input channel 7 of TIM module 0
	CCU60_CC61INC			T12 capture input 61
	SENT_SENT1C			Receive input channel 1
	EDSADC_DSCIN3B			Modulator clock input, channel 3
	EDSADC_ITR4E			Trigger/Gate input, channel 4
	GPT120_T3EUDA			Count direction control input of core timer T3
	PSI5_RX2B			RXD inputs (receive data) channel 2
	CCU60_CCPOS1A			Hall capture input 1
	QSPI3_SCLKA			Slave SPI clock inputs
	CCU61_T13HRB			External timer start 13
	P02.7			O0
	GTM_TOUT7	O1	GTM muxed output	
	IOM_REF0_7		Reference input 0	
	—	O2	Reserved	
	QSPI3_SCLK	O3	Master SPI clock output	
	EDSADC_DSCOUT3	O4	Modulator clock output	
	EVADC_EMUX01	O5	Control of external analog multiplexer interface 0	
SENT_SPC1	O6	Transmit output		
CCU60_CC61	O7	T12 PWM channel 61		
IOM_MON1_1		Monitor input 1		
IOM_REF1_5		Reference input 1		

## Pin Definition and Functions BGA292 Package Variant Pin Configuration

Table 2-27 Port 02 Functions (cont'd)

Ball	Symbol	Ctrl.	Buffer Type	Function
F1	P02.8	I	SLOW / PU1 / VEXT / ES	General-purpose input
	GTM_TIM3_IN2_10			Mux input channel 2 of TIM module 3
	GTM_TIM3_IN0_2			Mux input channel 0 of TIM module 3
	GTM_TIM2_IN0_2			Mux input channel 0 of TIM module 2
	CCU60_CC62INC			T12 capture input 62
	SENT_SENT0C			Receive input channel 0
	CCU60_CCPOS2A			Hall capture input 2
	EDSADC_DSDIN3B			Digital datastream input, channel 3
	EDSADC_ITR3E			Trigger/Gate input, channel 3
	GPT120_T4INA			Trigger/gate input of timer T4
	CCU61_T12HRC			External timer start 12
	CCU61_T13HRC			External timer start 13
	GTM_DTMA0_1			CDTM0_DTM4
	P02.8			O0
	GTM_TOUT8	O1	GTM muxed output	
	IOM_REF0_8		Reference input 0	
	QSPI3_SLSO5	O2	Master slave select output	
	ASCLIN8_ASCLK	O3	Shift clock output	
	PSI5_TX2	O4	TXD outputs (send data)	
	IOM_REF1_15		Reference input 1	
EVADC_EMUX02	O5	Control of external analog multiplexer interface 0		
GETH_MDC	O6	MDIO clock		
CCU60_CC62	O7	T12 PWM channel 62		
IOM_MON1_0		Monitor input 1		
IOM_REF1_4		Reference input 1		

## Pin Definition and Functions BGA292 Package Variant Pin Configuration

Table 2-27 Port 02 Functions (cont'd)

Ball	Symbol	Ctrl.	Buffer Type	Function
E4	P02.9	I	SLOW / PU1 / VEXT / ES	General-purpose input
	GTM_TIM4_IN2_2			Mux input channel 2 of TIM module 4
	GTM_TIM3_IN3_10			Mux input channel 3 of TIM module 3
	GTM_TIM0_IN2_10			Mux input channel 2 of TIM module 0
	SENT_SENT20B			Receive input channel 20
	ASCLIN8_ARXA			Receive input
	P02.9	O0	General-purpose output	
	GTM_TOUT116	O1	GTM muxed output	
	ASCLIN2_ATX	O2	Transmit output	
	IOM_MON2_14		Monitor input 2	
	IOM_REF2_14	O3	Reference input 2	
	ASCLIN8_ATX		Transmit output	
	—	O4	Reserved	
	CAN01_TXD	O5	CAN transmit output node 1	
	IOM_MON2_6		Monitor input 2	
	IOM_REF2_6	O6	Reference input 2	
	—		Reserved	
—	O7	Reserved		
F5	P02.10	I	SLOW / PU1 / VEXT / ES	General-purpose input
	GTM_TIM4_IN3_2			Mux input channel 3 of TIM module 4
	GTM_TIM3_IN4_11			Mux input channel 4 of TIM module 3
	GTM_TIM0_IN3_10			Mux input channel 3 of TIM module 0
	ASCLIN2_ARXC			Receive input
	CAN01_RXDE			CAN receive input node 1
	SENT_SENT21B	Receive input channel 21		
	ASCLIN8_ARXB	Receive input		
	P02.10	O0	General-purpose output	
	GTM_TOUT117	O1	GTM muxed output	
	—	O2	Reserved	
	—	O3	Reserved	
	—	O4	Reserved	
	—	O5	Reserved	
	—	O6	Reserved	
	—	O7	Reserved	

## Pin Definition and Functions BGA292 Package Variant Pin Configuration

Table 2-27 Port 02 Functions (cont'd)

Ball	Symbol	Ctrl.	Buffer Type	Function
F4	P02.11	I	SLOW / PU1 / VEXT / ES	General-purpose input
	GTM_TIM4_IN4_3			Mux input channel 4 of TIM module 4
	GTM_TIM3_IN5_12			Mux input channel 5 of TIM module 3
	GTM_TIM0_IN7_7			Mux input channel 7 of TIM module 0
	SENT_SENT22B			Receive input channel 22
	EVADC_G9CH15			AI
	P02.11	O0	General-purpose output	
	GTM_TOUT118	O1	GTM muxed output	
	—	O2	Reserved	
	ASCLIN8_ASLSO	O3	Slave select signal output	
	—	O4	Reserved	
	—	O5	Reserved	
	—	O6	Reserved	
	—	O7	Reserved	

Table 2-28 Port 10 Functions

Ball	Symbol	Ctrl.	Buffer Type	Function
A7	P10.0	I	SLOW / PU1 / VEXT / ES	General-purpose input
	GTM_TIM4_IN0_12			Mux input channel 0 of TIM module 4
	GTM_TIM1_IN4_2			Mux input channel 4 of TIM module 1
	GTM_TIM0_IN4_2			Mux input channel 4 of TIM module 0
	GPT120_T6EUDB			Count direction control input of core timer T6
	ASCLIN11_ARXA			Receive input
	GETH_RXERC			Receive Error MII
	GTM_DTMA5_2			CDTM5_DTM4
	P10.0	O0	General-purpose output	
	GTM_TOUT102	O1	GTM muxed output	
	ASCLIN11_ATX	O2	Transmit output	
	QSPI1_SLSO10	O3	Master slave select output	
	—	O4	Reserved	
	—	O5	Reserved	
ASCLIN22_ATX	O6	Transmit output		
—	O7	Reserved		

## Pin Definition and Functions BGA292 Package Variant Pin Configuration

Table 2-28 Port 10 Functions (cont'd)

Ball	Symbol	Ctrl.	Buffer Type	Function	
B7	P10.1	I	FAST / PU1 / VEXT / ES	General-purpose input	
	GTM_TIM4_IN4_12			Mux input channel 4 of TIM module 4	
	GTM_TIM1_IN1_3			Mux input channel 1 of TIM module 1	
	GTM_TIM0_IN1_3			Mux input channel 1 of TIM module 0	
	GPT120_T5EUDB			Count direction control input of timer T5	
	QSPI1_MRSTA			Master SPI data input	
	GTM_DTMT0_1			CDTM0_DTM0	
	P10.1			O0	General-purpose output
	GTM_TOUT103			O1	GTM muxed output
	QSPI1_MTSR			O2	Master SPI data output
	QSPI1_MRST			O3	Slave SPI data output
	IOM_MON2_1				Monitor input 2
	IOM_REF2_1				Reference input 2
	MSC0_EN1			O4	Chip Select
	EVADC_FC1BFLOUT			O5	Boundary flag output, FC channel 1
	—			O6	Reserved
	—			O7	Reserved
A5	P10.2	I	FAST / PU1 / VEXT / ES	General-purpose input	
	GTM_TIM4_IN5_12			Mux input channel 5 of TIM module 4	
	GTM_TIM1_IN2_3			Mux input channel 2 of TIM module 1	
	GTM_TIM0_IN2_3			Mux input channel 2 of TIM module 0	
	CAN02_RXDE			CAN receive input node 2	
	MSC0_SD11			Upstream asynchronous input signal	
	QSPI1_SCLKA			Slave SPI clock inputs	
	GPT120_T6INB			Trigger/gate input of core timer T6	
	SCU_E_REQ2_0			ERU Channel 2 inputs 0 to 5 (0 is the LSB and 5 is the MSB)	
	GTM_DTMT2_2			CDTM2_DTM0	
	P10.2			O0	General-purpose output
	GTM_TOUT104			O1	GTM muxed output
	IOM_MON2_9				Monitor input 2
	—			O2	Reserved
	QSPI1_SCLK			O3	Master SPI clock output
	MSC0_EN0			O4	Chip Select
	EVADC_FC3BFLOUT			O5	Boundary flag output, FC channel 3
—	O6	Reserved			
—	O7	Reserved			

## Pin Definition and Functions BGA292 Package Variant Pin Configuration

Table 2-28 Port 10 Functions (cont'd)

Ball	Symbol	Ctrl.	Buffer Type	Function
A6	P10.3	I	FAST / PU1 / VEXT / ES	General-purpose input
	GTM_TIM4_IN6_10			Mux input channel 6 of TIM module 4
	GTM_TIM1_IN3_3			Mux input channel 3 of TIM module 1
	GTM_TIM0_IN3_3			Mux input channel 3 of TIM module 0
	QSPI1_MTSRA			Slave SPI data input
	SCU_E_REQ3_0			ERU Channel 3 inputs 0 to 5 (0 is the LSB and 5 is the MSB)
	GPT120_T5INB			Trigger/gate input of timer T5
	P10.3	O0	General-purpose output	
	GTM_TOUT105	O1	GTM muxed output	
	IOM_MON2_10		Monitor input 2	
	—	O2	Reserved	
	QSPI1_MTSR	O3	Master SPI data output	
	MSC0_EN0	O4	Chip Select	
	—	O5	Reserved	
	CAN02_TXD	O6	CAN transmit output node 2	
	IOM_MON2_7		Monitor input 2	
	IOM_REF2_7		Reference input 2	
—	O7	Reserved		
B6	P10.4	I	FAST / PU1 / VEXT / ES	General-purpose input
	GTM_TIM4_IN7_3			Mux input channel 7 of TIM module 4
	GTM_TIM1_IN6_2			Mux input channel 6 of TIM module 1
	GTM_TIM0_IN6_2			Mux input channel 6 of TIM module 0
	QSPI1_MTSRC			Slave SPI data input
	CCU60_CCPOS0C			Hall capture input 0
	GPT120_T3INB			Trigger/gate input of core timer T3
	ASCLIN11_ARXB	Receive input		
	ASCLIN22_ARXA	Receive input		
	P10.4	O0	General-purpose output	
	GTM_TOUT106	O1	GTM muxed output	
	IOM_MON2_11		Monitor input 2	
	ASCLIN22_ATX	O2	Transmit output	
	QSPI1_SLSO8	O3	Master slave select output	
	QSPI1_MTSR	O4	Master SPI data output	
	MSC0_EN0	O5	Chip Select	
	—	O6	Reserved	
—	O7	Reserved		

## Pin Definition and Functions BGA292 Package Variant Pin Configuration

Table 2-28 Port 10 Functions (cont'd)

Ball	Symbol	Ctrl.	Buffer Type	Function
B5	P10.5	I	SLOW / PU2 / VEXT / ES	General-purpose input
	GTM_TIM4_IN3_13			Mux input channel 3 of TIM module 4
	GTM_TIM1_IN2_4			Mux input channel 2 of TIM module 1
	GTM_TIM0_IN2_4			Mux input channel 2 of TIM module 0
	PMS_HWCFG4IN			HWCFG4 pin input
	CAN20_RXDA			CAN receive input node 0
	MSC0_INJ1			Injection signal from port
	ASCLIN22_ARXB			Receive input
	P10.5			O0
	GTM_TOUT107	O1	GTM muxed output	
	IOM_REF2_9	O2	Reference input 2	
	ASCLIN2_ATX		Transmit output	
	IOM_MON2_14		Monitor input 2	
	IOM_REF2_14	Reference input 2		
	QSPI3_SLSO8	O3	Master slave select output	
	QSPI1_SLSO9	O4	Master slave select output	
	GPT120_T6OUT	O5	External output for overflow/underflow detection of core timer T6	
	ASCLIN2_ASLSO	O6	Slave select signal output	
	PSI5_TX3	O7	TXD outputs (send data)	

## Pin Definition and Functions BGA292 Package Variant Pin Configuration

Table 2-28 Port 10 Functions (cont'd)

Ball	Symbol	Ctrl.	Buffer Type	Function
A4	P10.6	I	SLOW / PU2 / VEXT / ES	General-purpose input
	GTM_TIM4_IN2_13			Mux input channel 2 of TIM module 4
	GTM_TIM1_IN3_4			Mux input channel 3 of TIM module 1
	GTM_TIM0_IN3_4			Mux input channel 3 of TIM module 0
	PSI5_RX3C			RXD inputs (receive data) channel 3
	ASCLIN2_ARXD			Receive input
	QSPI3_MTSRB			Slave SPI data input
	PMS_HWCFG5IN			HWCFG5 pin input
	ASCLIN23_ARXA			Receive input
	P10.6			O0
	GTM_TOUT108	O1	GTM muxed output	
	IOM_REF2_10		Reference input 2	
	ASCLIN2_ASCLK	O2	Shift clock output	
	QSPI3_MTSR	O3	Master SPI data output	
	GPT120_T3OUT	O4	External output for overflow/underflow detection of core timer T3	
	CAN20_TXD	O5	CAN transmit output node 0	
	QSPI1_MRST	O6	Slave SPI data output	
	IOM_MON2_1		Monitor input 2	
	IOM_REF2_1		Reference input 2	
	—	O7	Reserved	

## Pin Definition and Functions BGA292 Package Variant Pin Configuration

Table 2-28 Port 10 Functions (cont'd)

Ball	Symbol	Ctrl.	Buffer Type	Function
A3	P10.7	I	SLOW / PU1 / VEXT / ES	General-purpose input
	GTM_TIM1_IN0_3			Mux input channel 0 of TIM module 1
	GTM_TIM0_IN0_3			Mux input channel 0 of TIM module 0
	GPT120_T3EUDB			Count direction control input of core timer T3
	ASCLIN2_ACTSA			Clear to send input
	QSPI3_MRSTB			Master SPI data input
	SCU_E_REQ0_2			ERU Channel 0 inputs 0 to 5 (0 is the LSB and 5 is the MSB)
	CCU60_CCPOS1C			Hall capture input 1
	ASCLIN23_ARXB			Receive input
	P10.7			O0
	GTM_TOUT109	O1	GTM muxed output	
	IOM_REF2_11		Reference input 2	
	ASCLIN23_ATX	O2	Transmit output	
	QSPI3_MRST	O3	Slave SPI data output	
	IOM_MON2_3		Monitor input 2	
	IOM_REF2_3		Reference input 2	
	—	O4	Reserved	
	CAN20_TXD	O5	CAN transmit output node 0	
	CAN12_TXD	O6	CAN transmit output node 2	
—	O7	Reserved		

## Pin Definition and Functions BGA292 Package Variant Pin Configuration

Table 2-28 Port 10 Functions (cont'd)

Ball	Symbol	Ctrl.	Buffer Type	Function
B4	P10.8	I	SLOW / PU1 / VEXT / ES	General-purpose input
	GTM_TIM4_IN0_13			Mux input channel 0 of TIM module 4
	GTM_TIM1_IN5_2			Mux input channel 5 of TIM module 1
	GTM_TIM0_IN5_2			Mux input channel 5 of TIM module 0
	CAN12_RXDB			CAN receive input node 2
	GPT120_T4INB			Trigger/gate input of timer T4
	QSPI3_SCLKB			Slave SPI clock inputs
	SCU_E_REQ1_2			ERU Channel 1 inputs 0 to 5 (0 is the LSB and 5 is the MSB)
	CCU60_CCPOS2C			Hall capture input 2
	CAN20_RXDB			CAN receive input node 0
	P10.8	O0	General-purpose output	
	GTM_TOUT110	O1	GTM muxed output	
	ASCLIN2_ARTS	O2	Ready to send output	
	QSPI3_SCLK	O3	Master SPI clock output	
	ASCLIN23_ATX	O4	Transmit output	
	—	O5	Reserved	
	—	O6	Reserved	
—	O7	Reserved		

Table 2-29 Port 11 Functions

Ball	Symbol	Ctrl.	Buffer Type	Function
E10	P11.0	I	RFast / PU1 / VFLEX / ES	General-purpose input
	GTM_TIM4_IN0_4			Mux input channel 0 of TIM module 4
	GTM_TIM2_IN0_7			Mux input channel 0 of TIM module 2
	ASCLIN3_ARXB			Receive input
	GTM_DTMA2_1			CDTM2_DTM4
	P11.0	O0	General-purpose output	
	GTM_TOUT119	O1	GTM muxed output	
	ASCLIN3_ATX	O2	Transmit output	
	IOM_MON2_15		Monitor input 2	
	IOM_REF2_15		Reference input 2	
	—		O3	Reserved
	—	O4	Reserved	
	CAN11_TXD	O5	CAN transmit output node 1	
	GETH_TXD3	O6	Transmit Data	
	—	O7	Reserved	

## Pin Definition and Functions BGA292 Package Variant Pin Configuration

Table 2-29 Port 11 Functions (cont'd)

Ball	Symbol	Ctrl.	Buffer Type	Function
E9	P11.1	I	RFAST / PU1 / VFLEX / ES	General-purpose input
	GTM_TIM4_IN1_5			Mux input channel 1 of TIM module 4
	GTM_TIM2_IN1_6			Mux input channel 1 of TIM module 2
	P11.1	O0		General-purpose output
	GTM_TOUT120	O1		GTM muxed output
	ASCLIN3_ASCLK	O2		Shift clock output
	ASCLIN3_ATX	O3		Transmit output
	IOM_MON2_15			Monitor input 2
	IOM_REF2_15			Reference input 2
	—	O4		Reserved
	CAN12_TXD	O5		CAN transmit output node 2
	GETH_TXD2	O6		Transmit Data
	—	O7		Reserved
A10	P11.2	I	RFAST / PU1 / VFLEX / ES	General-purpose input
	GTM_TIM3_IN1_3			Mux input channel 1 of TIM module 3
	GTM_TIM2_IN1_3			Mux input channel 1 of TIM module 2
	P11.2	O0		General-purpose output
	GTM_TOUT95	O1		GTM muxed output
	—	O2		Reserved
	QSPIO_SLSO5	O3		Master slave select output
	QSPI1_SLSO5	O4		Master slave select output
	MSC0_EN1	O5		Chip Select
	GETH_TXD1	O6		Transmit Data
	CCU60_COUT63	O7		T13 PWM channel 63
	IOM_MON1_6			Monitor input 1
	IOM_REF1_0			Reference input 1

## Pin Definition and Functions BGA292 Package Variant Pin Configuration

Table 2-29 Port 11 Functions (cont'd)

Ball	Symbol	Ctrl.	Buffer Type	Function	
B10	P11.3	I	RFAST / PU1 / VFLEX / ES	General-purpose input	
	GTM_TIM3_IN2_2			Mux input channel 2 of TIM module 3	
	GTM_TIM2_IN2_2			Mux input channel 2 of TIM module 2	
	MSC0_SDI3			Upstream asynchronous input signal	
	QSPI1_MRSTB			Master SPI data input	
	P11.3			O0	General-purpose output
	GTM_TOUT96			O1	GTM muxed output
	—			O2	Reserved
	QSPI1_MRST			O3	Slave SPI data output
	IOM_MON2_1				Monitor input 2
	IOM_REF2_1				Reference input 2
	ERAY0_TXDA				O4
	—			O5	Reserved
	GETH_TXD0			O6	Transmit Data
	CCU60_COUT62			O7	T12 PWM channel 62
	IOM_MON1_5				Monitor input 1
IOM_REF1_1	Reference input 1				
D10	P11.4	I	RFAST / PU1 / VFLEX / ES	General-purpose input	
	GTM_TIM4_IN2_5			Mux input channel 2 of TIM module 4	
	GTM_TIM2_IN2_6			Mux input channel 2 of TIM module 2	
	GETH_RXCLKB			Receive Clock MII	
	P11.4			O0	General-purpose output
	GTM_TOUT121			O1	GTM muxed output
	ASCLIN3_ASCLK			O2	Shift clock output
	—			O3	Reserved
	—			O4	Reserved
	CAN13_TXD			O5	CAN transmit output node 3
	GETH_TXER			O6	Transmit Error MII
	GETH_TXCLK			O7	Transmit Clock Output for RGMII

## Pin Definition and Functions BGA292 Package Variant Pin Configuration

Table 2-29 Port 11 Functions (cont'd)

Ball	Symbol	Ctrl.	Buffer Type	Function
D8	P11.5	I	SLOW / RGMII_In put / PU1 / VFLEX / ES	General-purpose input
	GTM_TIM4_IN3_5			Mux input channel 3 of TIM module 4
	GTM_TIM2_IN3_8			Mux input channel 3 of TIM module 2
	GETH_TXCLKA			Transmit Clock Input for MII
	GETH_GREFCLK			Gigabit Reference Clock input for RGMII (125 MHz high precision)
	P11.5	O0	General-purpose output	
	GTM_TOUT122	O1	GTM muxed output	
	—	O2	Reserved	
	—	O3	Reserved	
	—	O4	Reserved	
	CAN20_TXD	O5	CAN transmit output node 0	
	—	O6	Reserved	
—	O7	Reserved		
D9	P11.6	I	RFAST / PU1 / VFLEX / ES	General-purpose input
	GTM_TIM3_IN3_2			Mux input channel 3 of TIM module 3
	GTM_TIM2_IN3_2			Mux input channel 3 of TIM module 2
	QSPI1_SCLKB			Slave SPI clock inputs
	P11.6	O0	General-purpose output	
	GTM_TOUT97	O1	GTM muxed output	
	ERAY0_TXENB	O2	Transmit Enable Channel B	
	QSPI1_SCLK	O3	Master SPI clock output	
	ERAY0_TXENA	O4	Transmit Enable Channel A	
	MSC0_FCLP	O5	Shift-clock direct part of the differential signal	
	GETH_TXEN	O6	Transmit Enable MII and RMII	
	GETH_TCTL		Transmit Control for RGMII	
	CCU60_COUT61	O7	T12 PWM channel 61	
	IOM_MON1_4		Monitor input 1	
	IOM_REF1_2		Reference input 1	

## Pin Definition and Functions BGA292 Package Variant Pin Configuration

Table 2-29 Port 11 Functions (cont'd)

Ball	Symbol	Ctrl.	Buffer Type	Function
E8	P11.7	I	SLOW / RGMII_ Input / PU1 / VFLEX / ES	General-purpose input
	GTM_TIM4_IN4_5			Mux input channel 4 of TIM module 4
	GTM_TIM2_IN4_7			Mux input channel 4 of TIM module 2
	GETH_RXD3A			Receive Data 3 MII and RGMII (RGMII can use RXD3A only)
	CAN11_RXDD			CAN receive input node 1
	P11.7	O0	General-purpose output	
	GTM_TOUT123	O1	GTM muxed output	
	—	O2	Reserved	
	—	O3	Reserved	
	—	O4	Reserved	
	—	O5	Reserved	
	—	O6	Reserved	
	—	O7	Reserved	
E7	P11.8	I	SLOW / RGMII_ Input / PU1 / VFLEX / ES	General-purpose input
	GTM_TIM4_IN5_5			Mux input channel 5 of TIM module 4
	GTM_TIM2_IN5_8			Mux input channel 5 of TIM module 2
	GETH_RXD2A			Receive Data 2 MII and RGMII (RGMII can use RXD2A only)
	CAN12_RXDD			CAN receive input node 2
	P11.8	O0	General-purpose output	
	GTM_TOUT124	O1	GTM muxed output	
	—	O2	Reserved	
	—	O3	Reserved	
	—	O4	Reserved	
	—	O5	Reserved	
	—	O6	Reserved	
	—	O7	Reserved	

## Pin Definition and Functions BGA292 Package Variant Pin Configuration

Table 2-29 Port 11 Functions (cont'd)

Ball	Symbol	Ctrl.	Buffer Type	Function
A9	P11.9	I	FAST / RGMII_Input / PU1 / VFLEX / ES	General-purpose input
	GTM_TIM3_IN4_2			Mux input channel 4 of TIM module 3
	GTM_TIM2_IN4_2			Mux input channel 4 of TIM module 2
	QSPI1_MTSRB			Slave SPI data input
	ERAY0_RXDA1			Receive Channel A1
	GETH_RXD1A			Receive Data 1 MII, RMII and RGMII (RGMII can use RXD1A only)
	P11.9	O0	FAST / RGMII_Input / PU1 / VFLEX / ES	General-purpose output
	GTM_TOUT98	O1		GTM muxed output
	—	O2		Reserved
	QSPI1_MTSR	O3		Master SPI data output
	—	O4		Reserved
	MSC0_SOP	O5		Data output - direct part of the differential signal
	—	O6		Reserved
	CCU60_COUT60	O7		T12 PWM channel 60
	IOM_MON1_3			Monitor input 1
	IOM_REF1_3			Reference input 1

## Pin Definition and Functions BGA292 Package Variant Pin Configuration

Table 2-29 Port 11 Functions (cont'd)

Ball	Symbol	Ctrl.	Buffer Type	Function	
B9	P11.10	I	FAST / RGMII_Input / PU1 / VFLEX / ES	General-purpose input	
	GTM_TIM3_IN5_2			Mux input channel 5 of TIM module 3	
	GTM_TIM2_IN5_2			Mux input channel 5 of TIM module 2	
	GTM_TIM2_IN0_9			Mux input channel 0 of TIM module 2	
	CAN03_RXDD			CAN receive input node 3	
	ERAY0_RXDB1			Receive Channel B1	
	ASCLIN1_ARXE			Receive input	
	SCU_E_REQ6_3			ERU Channel 6 inputs 0 to 5 (0 is the LSB and 5 is the MSB)	
	MSC0_SDI0			Upstream asynchronous input signal	
	GETH_RXD0A			Receive Data 0 MII, RMI and RGMII (RGMII can use RXD0A only)	
	QSPI1_SLSIA			Slave select input	
	P11.10			O0	General-purpose output
	GTM_TOUT99			O1	GTM muxed output
	—			O2	Reserved
QSPI0_SLSO3	O3	Master slave select output			
QSPI1_SLSO3	O4	Master slave select output			
—	O5	Reserved			
—	O6	Reserved			
CCU60_CC62	O7	T12 PWM channel 62			
IOM_MON1_0		Monitor input 1			
IOM_REF1_4		Reference input 1			

## Pin Definition and Functions BGA292 Package Variant Pin Configuration

Table 2-29 Port 11 Functions (cont'd)

Ball	Symbol	Ctrl.	Buffer Type	Function
A8	P11.11	I	FAST / RGMII_In put / PU1 / VFLEX / ES	General-purpose input
	GTM_TIM3_IN6_2			Mux input channel 6 of TIM module 3
	GTM_TIM3_IN0_14			Mux input channel 0 of TIM module 3
	GTM_TIM2_IN6_2			Mux input channel 6 of TIM module 2
	GETH_CRSDVA			Carrier Sense / Data Valid combi-signal for RMII
	GETH_RXDVA			Receive Data Valid MII
	GETH_CRSB			Carrier Sense MII
	GETH_RCTLA			Receive Control for RGMII
	P11.11	O0	General-purpose output	
	GTM_TOUT100	O1	GTM muxed output	
	—	O2	Reserved	
	QSPIO_SLSO4	O3	Master slave select output	
	QSPI1_SLSO4	O4	Master slave select output	
	MSC0_EN0	O5	Chip Select	
	ERAY0_TXENB	O6	Transmit Enable Channel B	
	CCU60_CC61	O7	T12 PWM channel 61	
	IOM_MON1_1		Monitor input 1	
IOM_REF1_5		Reference input 1		
B8	P11.12	I	FAST / RGMII_In put / PU1 / VFLEX / ES	General-purpose input
	GTM_TIM3_IN7_2			Mux input channel 7 of TIM module 3
	GTM_TIM2_IN7_2			Mux input channel 7 of TIM module 2
	GETH_REFCLKA			Reference Clock input for RMII (50 MHz)
	GETH_TXCLKB			Transmit Clock Input for MII
	GETH_RXCLKA			Receive Clock MII
	P11.12	O0	General-purpose output	
	GTM_TOUT101	O1	GTM muxed output	
	ASCLIN1_ATX	O2	Transmit output	
	IOM_MON2_13		Monitor input 2	
	IOM_REF2_13		Reference input 2	
	GTM_CLK2	O3	CGM generated clock	
	ERAY0_TXDB	O4	Transmit Channel B	
	CAN03_TXD	O5	CAN transmit output node 3	
	IOM_MON2_8		Monitor input 2	
	IOM_REF2_8		Reference input 2	
	CCU_EXTCLK1	O6	External Clock 1	
CCU60_CC60	O7	T12 PWM channel 60		
IOM_MON1_2		Monitor input 1		
IOM_REF1_6		Reference input 1		

## Pin Definition and Functions BGA292 Package Variant Pin Configuration

Table 2-29 Port 11 Functions (cont'd)

Ball	Symbol	Ctrl.	Buffer Type	Function
E6	P11.13	I	SLOW / PU1 / VFLEX / ES	General-purpose input
	GTM_TIM4_IN6_5			Mux input channel 6 of TIM module 4
	GTM_TIM2_IN6_7			Mux input channel 6 of TIM module 2
	GETH_RXERA			Receive Error MII
	I2C1_SDAA			Serial Data Input 0
	CAN13_RXDD			CAN receive input node 3
	P11.13			O0
	GTM_TOUT125	O1	GTM muxed output	
	—	O2	Reserved	
	—	O3	Reserved	
	—	O4	Reserved	
	—	O5	Reserved	
	I2C1_SDA	O6	Serial Data Output	
	—	O7	Reserved	
D7	P11.14	I	SLOW / PU1 / VFLEX / ES	General-purpose input
	GTM_TIM4_IN7_4			Mux input channel 7 of TIM module 4
	GTM_TIM2_IN7_8			Mux input channel 7 of TIM module 2
	GETH_CRSDVB			Carrier Sense / Data Valid combi-signal for RMII
	GETH_RXDVB			Receive Data Valid MII
	GETH_CRSA			Carrier Sense MII
	I2C1_SCLA			Serial Clock Input 0
	CAN20_RXDF	CAN receive input node 0		
	P11.14	O0	General-purpose output	
	GTM_TOUT126	O1	GTM muxed output	
	—	O2	Reserved	
	—	O3	Reserved	
	—	O4	Reserved	
	—	O5	Reserved	
I2C1_SCL	O6	Serial Clock Output		
—	O7	Reserved		

## Pin Definition and Functions BGA292 Package Variant Pin Configuration

Table 2-29 Port 11 Functions (cont'd)

Ball	Symbol	Ctrl.	Buffer Type	Function
D6	P11.15	I	SLOW / PU1 / VFLEX / ES	General-purpose input
	GTM_TIM4_IN7_5			Mux input channel 7 of TIM module 4
	GTM_TIM0_IN7_8			Mux input channel 7 of TIM module 0
	GETH_COLA			Collision MII
	P11.15	O0		General-purpose output
	GTM_TOUT127	O1		GTM muxed output
	—	O2		Reserved
	—	O3		Reserved
	—	O4		Reserved
	—	O5		Reserved
	—	O6		Reserved
	—	O7		Reserved

Table 2-30 Port 12 Functions

Ball	Symbol	Ctrl.	Buffer Type	Function
E12	P12.0	I	SLOW / PU1 / VFLEX / ES	General-purpose input
	GTM_TIM4_IN0_5			Mux input channel 0 of TIM module 4
	GTM_TIM3_IN0_7			Mux input channel 0 of TIM module 3
	CAN00_RXDC			CAN receive input node 0
	GETH_RXCLKC			Receive Clock MII
	GTM_DTMA4_0			CDTM4_DTM4
	P12.0	O0		General-purpose output
	GTM_TOUT128	O1		GTM muxed output
	—	O2		Reserved
	—	O3		Reserved
	—	O4		Reserved
	—	O5		Reserved
	GETH_MDC	O6		MDIO clock
—	O7	Reserved		

## Pin Definition and Functions BGA292 Package Variant Pin Configuration

Table 2-30 Port 12 Functions (cont'd)

Ball	Symbol	Ctrl.	Buffer Type	Function
E11	P12.1	I	SLOW / PU1 / VFLEX / ES	General-purpose input
	GTM_TIM4_IN1_6			Mux input channel 1 of TIM module 4
	GTM_TIM3_IN1_6			Mux input channel 1 of TIM module 3
	GETH_MDIOC			MDIO Input
	P12.1	O0	General-purpose output	
	GTM_TOUT129	O1	GTM muxed output	
	ASCLIN3_ASLSO	O2	Slave select signal output	
	—	O3	Reserved	
	—	O4	Reserved	
	CAN00_TXD	O5	CAN transmit output node 0	
	IOM_MON2_5		Monitor input 2	
	IOM_REF2_5		Reference input 2	
	—	O6	Reserved	
	—	O7	Reserved	
	GETH_MDIO	O	MDIO Output	

Table 2-31 Port 13 Functions

Ball	Symbol	Ctrl.	Buffer Type	Function
B12	P13.0	I	LVDS_TX / FAST / PU1 / VEXT / ES6	General-purpose input
	GTM_TIM3_IN5_3			Mux input channel 5 of TIM module 3
	GTM_TIM2_IN5_3			Mux input channel 5 of TIM module 2
	ASCLIN10_ARXC			Receive input
	ASCLIN21_ARXA			Receive input
	P13.0	O0	General-purpose output	
	GTM_TOUT91	O1	GTM muxed output	
	ASCLIN10_ATX	O2	Transmit output	
	QSPI2_SCLKN	O3	Master SPI clock output (LVDS N line)	
	MSC0_EN1	O4	Chip Select	
	MSC0_FCLN	O5	Shift-clock inverted part of the differential signal	
	—	O6	Reserved	
	CAN10_TXD	O7	CAN transmit output node 0	

## Pin Definition and Functions BGA292 Package Variant Pin Configuration

Table 2-31 Port 13 Functions (cont'd)

Ball	Symbol	Ctrl.	Buffer Type	Function
A12	P13.1	I	LVDS_TX / FAST / PU1 / VEXT / ES6	General-purpose input
	GTM_TIM3_IN6_3			Mux input channel 6 of TIM module 3
	GTM_TIM2_IN6_3			Mux input channel 6 of TIM module 2
	I2C0_SCLB			Serial Clock Input 1
	CAN10_RXDD			CAN receive input node 0
	ASCLIN10_ARXD			Receive input
	P13.1			O0
	GTM_TOUT92	O1	GTM muxed output	
	—	O2	Reserved	
	QSPI2_SCLKP	O3	Master SPI clock output (LVDS P line)	
	—	O4	Reserved	
	MSC0_FCLP	O5	Shift-clock direct part of the differential signal	
	I2C0_SCL	O6	Serial Clock Output	
	—	O7	Reserved	
B11	P13.2	I	LVDS_TX / FAST / PU1 / VEXT / ES6	General-purpose input
	GTM_TIM3_IN7_3			Mux input channel 7 of TIM module 3
	GTM_TIM2_IN7_3			Mux input channel 7 of TIM module 2
	GPT120_CAPINA			Trigger input to capture value of timer T5 into CAPREL register
	I2C0_SDAB			Serial Data Input 1
	P13.2	O0		General-purpose output
	GTM_TOUT93	O1		GTM muxed output
	ASCLIN10_ASCLK	O2		Shift clock output
	QSPI2_MTSRN	O3		Master SPI data output (LVDS N line)
	MSC0_FCLP	O4		Shift-clock direct part of the differential signal
	MSC0_SON	O5		Data output - inverted part of the differential signal
	I2C0_SDA	O6		Serial Data Output
	ASCLIN21_ATX	O7		Transmit output

## Pin Definition and Functions BGA292 Package Variant Pin Configuration

Table 2-31 Port 13 Functions (cont'd)

Ball	Symbol	Ctrl.	Buffer Type	Function
A11	P13.3	I	LVDS_TX / FAST / PU1 / VEXT / ES6	General-purpose input
	GTM_TIM3_IN0_3			Mux input channel 0 of TIM module 3
	GTM_TIM2_IN0_3			Mux input channel 0 of TIM module 2
	ASCLIN21_ARXB			Receive input
	P13.3	O0		General-purpose output
	GTM_TOUT94	O1		GTM muxed output
	ASCLIN10_ASLSO	O2		Slave select signal output
	QSPI2_MTSRP	O3		Master SPI data output (LVDS P line)
	—	O4		Reserved
	MSC0_SOP	O5		Data output - direct part of the differential signal
	ASCLIN21_ATX	O6		Transmit output
	—	O7		Reserved

Table 2-32 Port 14 Functions

Ball	Symbol	Ctrl.	Buffer Type	Function
B16	P14.0	I	FAST / PU1 / VEXT / ES2	General-purpose input
	GTM_TIM1_IN3_5			Mux input channel 3 of TIM module 1
	GTM_TIM0_IN3_5			Mux input channel 3 of TIM module 0
	SENT_SENT17D			Receive input channel 17
	P14.0	O0		General-purpose output
	GTM_TOUT80	O1		GTM muxed output
	ASCLIN0_ATX	O2		Transmit output
	IOM_MON2_12			Monitor input 2
	IOM_REF2_12			Reference input 2
	ERAY0_TXDA	O3		Transmit Channel A
	ERAY0_TXDB	O4		Transmit Channel B
	CAN01_TXD	O5		CAN transmit output node 1
	IOM_MON2_6			Monitor input 2
	IOM_REF2_6			Reference input 2
	ASCLIN0_ASCLK	O6		Shift clock output
	CCU60_COUT62	O7		T12 PWM channel 62
	IOM_MON1_5			Monitor input 1
	IOM_REF1_1			Reference input 1

## Pin Definition and Functions BGA292 Package Variant Pin Configuration

Table 2-32 Port 14 Functions (cont'd)

Ball	Symbol	Ctrl.	Buffer Type	Function
A15	P14.1	I	FAST / PU1 / VEXT / ES2	General-purpose input
	GTM_TIM1_IN4_3			Mux input channel 4 of TIM module 1
	GTM_TIM0_IN4_3			Mux input channel 4 of TIM module 0
	ERAY0_RXDA3			Receive Channel A3
	ASCLIN0_ARXA			Receive input
	SENT_SENT18D			Receive input channel 18
	ERAY0_RXDB3			Receive Channel B3
	CAN01_RXDB			CAN receive input node 1
	SCU_E_REQ3_1			ERU Channel 3 inputs 0 to 5 (0 is the LSB and 5 is the MSB)
	PMS_PINAWKP			PINA ( P14.1) pin input
	P14.1	O0	General-purpose output	
	GTM_TOUT81	O1	GTM muxed output	
	ASCLIN0_ATX	O2	Transmit output	
	IOM_MON2_12		Monitor input 2	
	IOM_REF2_12		Reference input 2	
	—	O3	Reserved	
	—	O4	Reserved	
	—	O5	Reserved	
	—	O6	Reserved	
	CCU60_COUT63	O7	T13 PWM channel 63	
IOM_MON1_6		Monitor input 1		
IOM_REF1_0		Reference input 1		
E13	P14.2	I	SLOW / PU2 / VEXT / ES	General-purpose input
	GTM_TIM1_IN5_3			Mux input channel 5 of TIM module 1
	GTM_TIM0_IN5_3			Mux input channel 5 of TIM module 0
	PMS_HWCFG2IN			HWCFG2 pin input
	P14.2	O0	General-purpose output	
	GTM_TOUT82	O1	GTM muxed output	
	ASCLIN2_ATX	O2	Transmit output	
	IOM_MON2_14		Monitor input 2	
	IOM_REF2_14		Reference input 2	
	QSPI2_SLSO1	O3	Master slave select output	
	—	O4	Reserved	
	—	O5	Reserved	
	ASCLIN2_ASCLK	O6	Shift clock output	
	—	O7	Reserved	

## Pin Definition and Functions BGA292 Package Variant Pin Configuration

Table 2-32 Port 14 Functions (cont'd)

Ball	Symbol	Ctrl.	Buffer Type	Function
B14	P14.3	I	SLOW / PU2 / VEXT / ES	General-purpose input
	GTM_TIM1_IN6_3			Mux input channel 6 of TIM module 1
	GTM_TIM0_IN6_3			Mux input channel 6 of TIM module 0
	PMS_HWCFG3IN			HWCFG3 pin input
	ASCLIN2_ARXA			Receive input
	MSC0_SDI2			Upstream assynchronous input signal
	SCU_E_REQ1_0			ERU Channel 1 inputs 0 to 5 (0 is the LSB and 5 is the MSB)
	P14.3	O0	General-purpose output	
	GTM_TOUT83	O1	GTM muxed output	
	ASCLIN2_ATX	O2	Transmit output	
	IOM_MON2_14		Monitor input 2	
	IOM_REF2_14		Reference input 2	
	QSPI2_SLSO3	O3	Master slave select output	
	ASCLIN1_ASLSO	O4	Slave select signal output	
	ASCLIN3_ASLSO	O5	Slave select signal output	
	—	O6	Reserved	
	—	O7	Reserved	
B15	P14.4	I	SLOW / PU2 / VEXT / ES	General-purpose input
	GTM_TIM1_IN7_2			Mux input channel 7 of TIM module 1
	GTM_TIM0_IN7_2			Mux input channel 7 of TIM module 0
	PMS_HWCFG6IN			HWCFG6 pin input
	GTM_DTMT0_0			CDTM0_DTM0
	P14.4	O0	General-purpose output	
	GTM_TOUT84	O1	GTM muxed output	
	—	O2	Reserved	
	—	O3	Reserved	
	—	O4	Reserved	
	—	O5	Reserved	
	GETH_PPS	O6	Pulse Per Second	
	—	O7	Reserved	

## Pin Definition and Functions BGA292 Package Variant Pin Configuration

Table 2-32 Port 14 Functions (cont'd)

Ball	Symbol	Ctrl.	Buffer Type	Function
A14	P14.5	I	FAST / PU2 / VEXT / ES	General-purpose input
	GTM_TIM1_IN0_4			Mux input channel 0 of TIM module 1
	GTM_TIM0_IN0_4			Mux input channel 0 of TIM module 0
	PMS_HWCFG1IN			HWCFG1 pin input
	GTM_DTMA2_0			CDTM2_DTM4
	P14.5			O0
	GTM_TOUT85	O1	GTM muxed output	
	—	O2	Reserved	
	—	O3	Reserved	
	—	O4	Reserved	
	—	O5	Reserved	
	ERAY0_TXDB	O6	Transmit Channel B	
	ERAY1_TXDB	O7	Transmit Channel B	
B13	P14.6	I	FAST / PU1 / VEXT / ES	General-purpose input
	GTM_TIM1_IN1_4			Mux input channel 1 of TIM module 1
	GTM_TIM0_IN1_4			Mux input channel 1 of TIM module 0
	P14.6	O0	General-purpose output	
	GTM_TOUT86	O1	GTM muxed output	
	—	O2	Reserved	
	QSPI2_SLSO2	O3	Master slave select output	
	CAN13_TXD	O4	CAN transmit output node 3	
	—	O5	Reserved	
	ERAY0_TXENB	O6	Transmit Enable Channel B	
	ERAY1_TXENB	O7	Transmit Enable Channel B	

## Pin Definition and Functions BGA292 Package Variant Pin Configuration

Table 2-32 Port 14 Functions (cont'd)

Ball	Symbol	Ctrl.	Buffer Type	Function
D13	P14.7	I	SLOW / PU1 / VEXT / ES	General-purpose input
	GTM_TIM4_IN7_10			Mux input channel 7 of TIM module 4
	GTM_TIM1_IN0_5			Mux input channel 0 of TIM module 1
	GTM_TIM0_IN0_5			Mux input channel 0 of TIM module 0
	ERAY0_RXDB0			Receive Channel B0
	ERAY1_RXDB0			Receive Channel B0
	CAN10_RXDB			CAN receive input node 0
	CAN13_RXDA			CAN receive input node 3
	ASCLIN9_ARXC			Receive input
	ASCLIN20_ARXA			Receive input
	P14.7	O0	General-purpose output	
	GTM_TOUT87	O1	GTM muxed output	
	ASCLIN0_ARTS	O2	Ready to send output	
	QSPI2_SLSO4	O3	Master slave select output	
	ASCLIN9_ATX	O4	Transmit output	
	—	O5	Reserved	
	—	O6	Reserved	
ASCLIN20_ATX	O7	Transmit output		
A13	P14.8	I	SLOW / PU1 / VEXT / ES	General-purpose input
	GTM_TIM3_IN2_3			Mux input channel 2 of TIM module 3
	GTM_TIM2_IN2_3			Mux input channel 2 of TIM module 2
	ERAY0_RXDA0			Receive Channel A0
	CAN02_RXDD			CAN receive input node 2
	ASCLIN1_ARXD			Receive input
	ERAY1_RXDA0			Receive Channel A0
	P14.8	O0	General-purpose output	
	GTM_TOUT88	O1	GTM muxed output	
	ASCLIN5_ASLSO	O2	Slave select signal output	
	ASCLIN7_ASLSO	O3	Slave select signal output	
	—	O4	Reserved	
	—	O5	Reserved	
	—	O6	Reserved	
ASCLIN20_ATX	O7	Transmit output		

## Pin Definition and Functions BGA292 Package Variant Pin Configuration

Table 2-32 Port 14 Functions (cont'd)

Ball	Symbol	Ctrl.	Buffer Type	Function	
D12	P14.9	I	LVDS_R X/FAST/ PU1/ VEXT/ ES	General-purpose input	
	GTM_TIM3_IN3_3			Mux input channel 3 of TIM module 3	
	GTM_TIM2_IN3_3			Mux input channel 3 of TIM module 2	
	ASCLIN0_ACTSA			Clear to send input	
	QSPI2_MRSTFN			Master SPI data input (LVDS N line)	
	ASCLIN9_ARXD			Receive input	
	ASCLIN20_ARXB			Receive input	
	P14.9			O0	General-purpose output
	GTM_TOUT89			O1	GTM muxed output
	CAN23_TXD			O2	CAN transmit output node 3
	MSC0_EN1			O3	Chip Select
	CAN10_TXD			O4	CAN transmit output node 0
	ERAY0_TXENB			O5	Transmit Enable Channel B
	ERAY0_TXENA			O6	Transmit Enable Channel A
ERAY1_TXENA	O7	Transmit Enable Channel A			
D11	P14.10	I	LVDS_R X/FAST/ PU1/ VEXT/ ES	General-purpose input	
	GTM_TIM3_IN4_3			Mux input channel 4 of TIM module 3	
	GTM_TIM2_IN4_3			Mux input channel 4 of TIM module 2	
	CAN23_RXDA			CAN receive input node 3	
	QSPI2_MRSTFP			Master SPI data input (LVDS P line)	
	P14.10			O0	General-purpose output
	GTM_TOUT90			O1	GTM muxed output
	—			O2	Reserved
	MSC0_EN0			O3	Chip Select
	ASCLIN1_ATX			O4	Transmit output
	IOM_MON2_13			O5	Monitor input 2
	IOM_REF2_13				Reference input 2
	CAN02_TXD			O5	CAN transmit output node 2
	IOM_MON2_7			O6	Monitor input 2
IOM_REF2_7	Reference input 2				
ERAY0_TXDA	O6	Transmit Channel A			
ERAY1_TXDA	O7	Transmit Channel A			

## Pin Definition and Functions BGA292 Package Variant Pin Configuration

Table 2-33 Port 15 Functions

Ball	Symbol	Ctrl.	Buffer Type	Function
B20	P15.0	I	FAST / PU1 / VEXT / ES	<b>General-purpose input</b>
	GTM_TIM3_IN3_4			<b>Mux input channel 3 of TIM module 3</b>
	GTM_TIM2_IN3_4			<b>Mux input channel 3 of TIM module 2</b>
	P15.0	O0		<b>General-purpose output</b>
	GTM_TOUT71	O1		<b>GTM muxed output</b>
	ASCLIN1_ATX	O2		<b>Transmit output</b>
	IOM_MON2_13		<b>Monitor input 2</b>	
	IOM_REF2_13		<b>Reference input 2</b>	
	QSPI0_SLSO13	O3		<b>Master slave select output</b>
	—	O4		<b>Reserved</b>
	CAN02_TXD	O5		<b>CAN transmit output node 2</b>
	IOM_MON2_7		<b>Monitor input 2</b>	
	IOM_REF2_7		<b>Reference input 2</b>	
	ASCLIN1_ASCLK	O6		<b>Shift clock output</b>
	—	O7		<b>Reserved</b>
A18	P15.1	I	FAST / PU1 / VEXT / ES	<b>General-purpose input</b>
	GTM_TIM3_IN4_4			<b>Mux input channel 4 of TIM module 3</b>
	GTM_TIM2_IN4_4			<b>Mux input channel 4 of TIM module 2</b>
	CAN02_RXDA			<b>CAN receive input node 2</b>
	ASCLIN1_ARXA			<b>Receive input</b>
	QSPI2_SLSIB			<b>Slave select input</b>
	SCU_E_REQ7_2			<b>ERU Channel 7 inputs 0 to 5 (0 is the LSB and 5 is the MSB)</b>
	P15.1	O0		<b>General-purpose output</b>
	GTM_TOUT72	O1		<b>GTM muxed output</b>
	ASCLIN1_ATX	O2		<b>Transmit output</b>
	IOM_MON2_13		<b>Monitor input 2</b>	
	IOM_REF2_13		<b>Reference input 2</b>	
	QSPI2_SLSO5	O3		<b>Master slave select output</b>
	—	O4		<b>Reserved</b>
	—	O5		<b>Reserved</b>
—	O6		<b>Reserved</b>	
—	O7		<b>Reserved</b>	

## Pin Definition and Functions BGA292 Package Variant Pin Configuration

Table 2-33 Port 15 Functions (cont'd)

Ball	Symbol	Ctrl.	Buffer Type	Function
C19	P15.2	I	FAST / PU1 / VEXT / ES	General-purpose input
	GTM_TIM3_IN5_4			Mux input channel 5 of TIM module 3
	GTM_TIM2_IN5_4			Mux input channel 5 of TIM module 2
	QSPI2_SLSIA			Slave select input
	SENT_SENT10D			Receive input channel 10
	QSPI2_MRSTE			Master SPI data input
	P15.2	O0	General-purpose output	
	GTM_TOUT73	O1	GTM muxed output	
	ASCLIN0_ATX	O2	Transmit output	
	IOM_MON2_12		Monitor input 2	
	IOM_REF2_12		Reference input 2	
	QSPI2_SLSO0	O3	Master slave select output	
	—	O4	Reserved	
	CAN01_TXD	O5	CAN transmit output node 1	
	IOM_MON2_6	O6	Monitor input 2	
	IOM_REF2_6		Reference input 2	
	ASCLIN0_ASCLK		Shift clock output	
	—	O7	Reserved	
	B17	P15.3	I	FAST / PU1 / VEXT / ES
GTM_TIM3_IN6_4		Mux input channel 6 of TIM module 3		
GTM_TIM2_IN6_4		Mux input channel 6 of TIM module 2		
CAN01_RXDA		CAN receive input node 1		
ASCLIN0_ARXB		Receive input		
QSPI2_SCLKA		Slave SPI clock inputs		
P15.3		O0	General-purpose output	
GTM_TOUT74		O1	GTM muxed output	
ASCLIN0_ATX		O2	Transmit output	
IOM_MON2_12			Monitor input 2	
IOM_REF2_12			Reference input 2	
QSPI2_SCLK		O3	Master SPI clock output	
—		O4	Reserved	
MSC0_EN1		O5	Chip Select	
—		O6	Reserved	
—	O7	Reserved		

## Pin Definition and Functions BGA292 Package Variant Pin Configuration

Table 2-33 Port 15 Functions (cont'd)

Ball	Symbol	Ctrl.	Buffer Type	Function
A17	P15.4	I	FAST / PU1 / VEXT / ES	General-purpose input
	GTM_TIM3_IN7_4			Mux input channel 7 of TIM module 3
	GTM_TIM2_IN7_4			Mux input channel 7 of TIM module 2
	I2C0_SCLC			Serial Clock Input 2
	QSPI2_MRSTA			Master SPI data input
	SCU_E_REQ0_0			ERU Channel 0 inputs 0 to 5 (0 is the LSB and 5 is the MSB)
	SENT_SENT11D			Receive input channel 11
	P15.4			O0
	GTM_TOUT75	O1	GTM muxed output	
	ASCLIN1_ATX	O2	Transmit output	
	IOM_MON2_13		Monitor input 2	
	IOM_REF2_13		Reference input 2	
	QSPI2_MRST	O3	Slave SPI data output	
	IOM_MON2_2		Monitor input 2	
	IOM_REF2_2		Reference input 2	
	ASCLIN19_ATX	O4	Transmit output	
	—	O5	Reserved	
	I2C0_SCL	O6	Serial Clock Output	
	CCU60_CC62	O7	T12 PWM channel 62	
	IOM_MON1_0		Monitor input 1	
IOM_REF1_4	Reference input 1			

## Pin Definition and Functions BGA292 Package Variant Pin Configuration

Table 2-33 Port 15 Functions (cont'd)

Ball	Symbol	Ctrl.	Buffer Type	Function	
E14	P15.5	I	FAST / PU1 / VEXT / ES	General-purpose input	
	GTM_TIM3_IN0_4			Mux input channel 0 of TIM module 3	
	GTM_TIM2_IN0_4			Mux input channel 0 of TIM module 2	
	ASCLIN1_ARXB			Receive input	
	I2C0_SDAC			Serial Data Input 2	
	QSPI2_MTSRA			Slave SPI data input	
	SCU_E_REQ4_3			ERU Channel 4 inputs 0 to 5 (0 is the LSB and 5 is the MSB)	
	P15.5			O0	General-purpose output
	GTM_TOUT76			O1	GTM muxed output
	ASCLIN1_ATX			O2	Transmit output
	IOM_MON2_13			O2	Monitor input 2
	IOM_REF2_13				Reference input 2
	QSPI2_MTSR			O3	Master SPI data output
	—			O4	Reserved
	MSC0_EN0			O5	Chip Select
	I2C0_SDA			O6	Serial Data Output
CCU60_CC61	O7	T12 PWM channel 61			
IOM_MON1_1		Monitor input 1			
IOM_REF1_5		Reference input 1			
A16	P15.6	I	FAST / PU1 / VEXT / ES	General-purpose input	
	GTM_TIM2_IN2_14			Mux input channel 2 of TIM module 2	
	GTM_TIM1_IN0_6			Mux input channel 0 of TIM module 1	
	GTM_TIM0_IN0_6			Mux input channel 0 of TIM module 0	
	QSPI2_MTSRB			Slave SPI data input	
	ASCLIN19_ARXA			Receive input	
	P15.6			O0	General-purpose output
	GTM_TOUT77			O1	GTM muxed output
	ASCLIN3_ATX			O2	Transmit output
	IOM_MON2_15			O2	Monitor input 2
	IOM_REF2_15				Reference input 2
	QSPI2_MTSR			O3	Master SPI data output
	—			O4	Reserved
	QSPI2_SCLK			O5	Master SPI clock output
	ASCLIN3_ASCLK			O6	Shift clock output
	CCU60_CC60			O7	T12 PWM channel 60
IOM_MON1_2	Monitor input 1				
IOM_REF1_6	Reference input 1				

## Pin Definition and Functions BGA292 Package Variant Pin Configuration

Table 2-33 Port 15 Functions (cont'd)

Ball	Symbol	Ctrl.	Buffer Type	Function
D15	P15.7	I	FAST / PU1 / VEXT / ES	General-purpose input
	GTM_TIM1_IN1_5			Mux input channel 1 of TIM module 1
	GTM_TIM0_IN1_5			Mux input channel 1 of TIM module 0
	ASCLIN3_ARXA			Receive input
	QSPI2_MRSTB			Master SPI data input
	ASCLIN19_ARXB			Receive input
	P15.7	O0	General-purpose output	
	GTM_TOUT78	O1	GTM muxed output	
	ASCLIN3_ATX	O2	Transmit output	
	IOM_MON2_15		Monitor input 2	
	IOM_REF2_15		Reference input 2	
	QSPI2_MRST	O3	Slave SPI data output	
	IOM_MON2_2		Monitor input 2	
	IOM_REF2_2		Reference input 2	
	ASCLIN19_ATX	O4	Transmit output	
	—	O5	Reserved	
	—	O6	Reserved	
	CCU60_COUT60	O7	T12 PWM channel 60	
	IOM_MON1_3		Monitor input 1	
IOM_REF1_3	Reference input 1			
D14	P15.8	I	FAST / PU1 / VEXT / ES	General-purpose input
	GTM_TIM1_IN2_5			Mux input channel 2 of TIM module 1
	GTM_TIM0_IN2_5			Mux input channel 2 of TIM module 0
	QSPI2_SCLKB			Slave SPI clock inputs
	SCU_E_REQ5_0			ERU Channel 5 inputs 0 to 5 (0 is the LSB and 5 is the MSB)
	P15.8	O0	General-purpose output	
	GTM_TOUT79	O1	GTM muxed output	
	—	O2	Reserved	
	QSPI2_SCLK	O3	Master SPI clock output	
	—	O4	Reserved	
	—	O5	Reserved	
	ASCLIN3_ASCLK	O6	Shift clock output	
	CCU60_COUT61	O7	T12 PWM channel 61	
	IOM_MON1_4		Monitor input 1	
IOM_REF1_2	Reference input 1			

## Pin Definition and Functions BGA292 Package Variant Pin Configuration

Table 2-34 Port 20 Functions

Ball	Symbol	Ctrl.	Buffer Type	Function
H20	P20.0	I	FAST / PU1 / VEXT / ES	<b>General-purpose input</b>
	GTM_TIM1_IN6_7			<b>Mux input channel 6 of TIM module 1</b>
	GTM_TIM1_IN4_9			<b>Mux input channel 4 of TIM module 1</b>
	GTM_TIM0_IN6_7			<b>Mux input channel 6 of TIM module 0</b>
	CAN03_RXDC			<b>CAN receive input node 3</b>
	CCU_PAD_SYSCLK			<b>Sysclk input</b>
	CAN21_RXDC			<b>CAN receive input node 1</b>
	CBS_TGI0			<b>Trigger input</b>
	SCU_E_REQ6_0			<b>ERU Channel 6 inputs 0 to 5 (0 is the LSB and 5 is the MSB)</b>
	GPT120_T6EUDA			<b>Count direction control input of core timer T6</b>
	P20.0	O0	<b>General-purpose output</b>	
	GTM_TOUT59	O1	<b>GTM muxed output</b>	
	ASCLIN3_ATX	O2	<b>Transmit output</b>	
	IOM_MON2_15		<b>Monitor input 2</b>	
	IOM_REF2_15		<b>Reference input 2</b>	
	ASCLIN3_ASCLK	O3	<b>Shift clock output</b>	
	—	O4	<b>Reserved</b>	
	HSCT0_SYSCLK_OUT	O5	<b>sys clock output</b>	
	—	O6	<b>Reserved</b>	
	—	O7	<b>Reserved</b>	
CBS_TGO0	O	<b>Trigger output</b>		
G19	P20.1	I	SLOW / PU1 / VEXT / ES	<b>General-purpose input</b>
	GTM_TIM4_IN4_11			<b>Mux input channel 4 of TIM module 4</b>
	GTM_TIM3_IN3_5			<b>Mux input channel 3 of TIM module 3</b>
	GTM_TIM2_IN3_5			<b>Mux input channel 3 of TIM module 2</b>
	CBS_TGI1			<b>Trigger input</b>
	GTM_DTMA1_1			<b>CDTM1_DTM4</b>
	P20.1	O0	<b>General-purpose output</b>	
	GTM_TOUT60	O1	<b>GTM muxed output</b>	
	—	O2	<b>Reserved</b>	
	—	O3	<b>Reserved</b>	
	—	O4	<b>Reserved</b>	
	—	O5	<b>Reserved</b>	
	—	O6	<b>Reserved</b>	
	—	O7	<b>Reserved</b>	
	CBS_TGO1	O	<b>Trigger output</b>	

## Pin Definition and Functions BGA292 Package Variant Pin Configuration

Table 2-34 Port 20 Functions (cont'd)

Ball	Symbol	Ctrl.	Buffer Type	Function
H19	P20.2	I	S / PU / VEXT	<b>General-purpose input</b> This pin is latched at power on reset release to enter test mode.
	$\overline{\text{TESTMODE}}$			<b>Testmode Enable Input</b>
G20	P20.3	I	SLOW / PU1 / VEXT / ES	<b>General-purpose input</b>
	GTM_TIM4_IN5_11			<b>Mux input channel 5 of TIM module 4</b>
	GTM_TIM3_IN4_5			<b>Mux input channel 4 of TIM module 3</b>
	GTM_TIM2_IN4_5			<b>Mux input channel 4 of TIM module 2</b>
	ASCLIN3_ARXC			<b>Receive input</b>
	GPT120_T6INA			<b>Trigger/gate input of core timer T6</b>
	P20.3	O0		<b>General-purpose output</b>
	GTM_TOUT61	O1		<b>GTM muxed output</b>
	ASCLIN3_ATX	O2		<b>Transmit output</b>
	IOM_MON2_15			<b>Monitor input 2</b>
	IOM_REF2_15			<b>Reference input 2</b>
	QSPIO_SLSO9	O3		<b>Master slave select output</b>
	QSPI2_SLSO9	O4		<b>Master slave select output</b>
	CAN03_TXD	O5		<b>CAN transmit output node 3</b>
	IOM_MON2_8			<b>Monitor input 2</b>
	IOM_REF2_8			<b>Reference input 2</b>
	CAN21_TXD	O6		<b>CAN transmit output node 1</b>
—	O7	<b>Reserved</b>		
F17	P20.6	I	SLOW / PU1 / VEXT / ES	<b>General-purpose input</b>
	GTM_TIM6_IN0_1			<b>Mux input channel 0 of TIM module 6</b>
	GTM_TIM3_IN6_5			<b>Mux input channel 6 of TIM module 3</b>
	GTM_TIM2_IN6_5			<b>Mux input channel 6 of TIM module 2</b>
	CAN12_RXDA			<b>CAN receive input node 2</b>
	ASCLIN9_ARXE			<b>Receive input</b>
	P20.6	O0		<b>General-purpose output</b>
	GTM_TOUT62	O1		<b>GTM muxed output</b>
	ASCLIN1_ARTS	O2		<b>Ready to send output</b>
	QSPIO_SLSO8	O3		<b>Master slave select output</b>
	QSPI2_SLSO8	O4		<b>Master slave select output</b>
	—	O5		<b>Reserved</b>
	—	O6		<b>Reserved</b>
	—	O7		<b>Reserved</b>

## Pin Definition and Functions BGA292 Package Variant Pin Configuration

Table 2-34 Port 20 Functions (cont'd)

Ball	Symbol	Ctrl.	Buffer Type	Function
F19	P20.7	I	FAST / PU1 / VEXT / ES	General-purpose input
	GTM_TIM3_IN7_5			Mux input channel 7 of TIM module 3
	GTM_TIM2_IN7_5			Mux input channel 7 of TIM module 2
	GTM_TIM1_IN5_8			Mux input channel 5 of TIM module 1
	GTM_TIM6_IN1_1			Mux input channel 1 of TIM module 6
	CAN00_RXDB			CAN receive input node 0
	ASCLIN1_ACTSA			Clear to send input
	ASCLIN9_ARXF			Receive input
	P20.7			O0
	GTM_TOUT63	O1	GTM muxed output	
	ASCLIN9_ATX	O2	Transmit output	
	—	O3	Reserved	
	—	O4	Reserved	
	CAN12_TXD	O5	CAN transmit output node 2	
	—	O6	Reserved	
	CCU61_COUT63	O7	T13 PWM channel 63	
	IOM_MON1_7		Monitor input 1	
	IOM_REF1_7		Reference input 1	
F20	P20.8	I	FAST / PU1 / VEXT / ES	General-purpose input
	GTM_TIM6_IN2_1			Mux input channel 2 of TIM module 6
	GTM_TIM1_IN7_3			Mux input channel 7 of TIM module 1
	GTM_TIM0_IN7_3			Mux input channel 7 of TIM module 0
	P20.8	O0	General-purpose output	
	GTM_TOUT64	O1	GTM muxed output	
	ASCLIN1_ASLSO	O2	Slave select signal output	
	QSPI0_SLSO0	O3	Master slave select output	
	QSPI1_SLSO0	O4	Master slave select output	
	CAN00_TXD	O5	CAN transmit output node 0	
	IOM_MON2_5		Monitor input 2	
	IOM_REF2_5		Reference input 2	
	—	O6	Reserved	
	CCU61_CC60	O7	T12 PWM channel 60	
	IOM_MON1_8		Monitor input 1	
IOM_REF1_13		Reference input 1		

## Pin Definition and Functions BGA292 Package Variant Pin Configuration

Table 2-34 Port 20 Functions (cont'd)

Ball	Symbol	Ctrl.	Buffer Type	Function	
E17	P20.9	I	FAST / PU1 / VEXT / ES	General-purpose input	
	GTM_TIM6_IN3_1			Mux input channel 3 of TIM module 6	
	GTM_TIM3_IN5_5			Mux input channel 5 of TIM module 3	
	GTM_TIM2_IN5_5			Mux input channel 5 of TIM module 2	
	CAN03_RXDE			CAN receive input node 3	
	ASCLIN1_ARXC			Receive input	
	QSPIO_SLSIB			Slave select input	
	SCU_E_REQ7_0			ERU Channel 7 inputs 0 to 5 (0 is the LSB and 5 is the MSB)	
	P20.9			O0	General-purpose output
	GTM_TOUT65			O1	GTM muxed output
	—			O2	Reserved
	QSPIO_SLSO1			O3	Master slave select output
	QSPIO_SLSO1			O4	Master slave select output
	—			O5	Reserved
	—			O6	Reserved
	CCU61_CC61			O7	T12 PWM channel 61
	IOM_MON1_9				Monitor input 1
	IOM_REF1_12				Reference input 1
	E19			P20.10	I
GTM_TIM3_IN6_6		Mux input channel 6 of TIM module 3			
GTM_TIM2_IN6_6		Mux input channel 6 of TIM module 2			
P20.10		O0	General-purpose output		
GTM_TOUT66		O1	GTM muxed output		
ASCLIN1_ATX		O2	Transmit output		
IOM_MON2_13			Monitor input 2		
IOM_REF2_13			Reference input 2		
QSPIO_SLSO6		O3	Master slave select output		
QSPIO_SLSO7		O4	Master slave select output		
CAN03_TXD		O5	CAN transmit output node 3		
IOM_MON2_8			Monitor input 2		
IOM_REF2_8			Reference input 2		
ASCLIN1_ASCLK		O6	Shift clock output		
CCU61_CC62		O7	T12 PWM channel 62		
IOM_MON1_10			Monitor input 1		
IOM_REF1_11			Reference input 1		

## Pin Definition and Functions BGA292 Package Variant Pin Configuration

Table 2-34 Port 20 Functions (cont'd)

Ball	Symbol	Ctrl.	Buffer Type	Function
E20	P20.11	I	FAST / PU1 / VEXT / ES	General-purpose input
	GTM_TIM3_IN7_6			Mux input channel 7 of TIM module 3
	GTM_TIM2_IN7_6			Mux input channel 7 of TIM module 2
	QSPIO_SCLKA			Slave SPI clock inputs
	P20.11	O0		General-purpose output
	GTM_TOUT67	O1		GTM muxed output
	—	O2		Reserved
	QSPIO_SCLK	O3		Master SPI clock output
	—	O4		Reserved
	—	O5		Reserved
	—	O6		Reserved
	CCU61_COUT60	O7		T12 PWM channel 60
	IOM_MON1_11			Monitor input 1
	IOM_REF1_10			Reference input 1
D19	P20.12	I	FAST / PU1 / VEXT / ES	General-purpose input
	GTM_TIM3_IN0_5			Mux input channel 0 of TIM module 3
	GTM_TIM2_IN0_5			Mux input channel 0 of TIM module 2
	QSPIO_MRSTA			Master SPI data input
	IOM_PIN_13	GPIO pad input to FPC		
	P20.12	O0		General-purpose output
	GTM_TOUT68	O1		GTM muxed output
	IOM_MON0_13	O2		Monitor input 0
	—			Reserved
	QSPIO_MRST			Slave SPI data output
	IOM_MON2_0	O3		Monitor input 2
	IOM_REF2_0			Reference input 2
	QSPIO_MTSR			Master SPI data output
	—	O5		Reserved
	—	O6		Reserved
	CCU61_COUT61	O7		T12 PWM channel 61
	IOM_MON1_12	O7		Monitor input 1
IOM_REF1_9	Reference input 1			

## Pin Definition and Functions BGA292 Package Variant Pin Configuration

Table 2-34 Port 20 Functions (cont'd)

Ball	Symbol	Ctrl.	Buffer Type	Function
D20	P20.13	I	FAST / PU1 / VEXT / ES	General-purpose input
	GTM_TIM3_IN1_4			Mux input channel 1 of TIM module 3
	GTM_TIM2_IN1_4			Mux input channel 1 of TIM module 2
	QSPIO_SLSIA			Slave select input
	IOM_PIN_14			GPIO pad input to FPC
	P20.13	O0		General-purpose output
	GTM_TOUT69	O1		GTM muxed output
	IOM_MON0_14			Monitor input 0
	—	O2		Reserved
	QSPIO_SLSO2	O3		Master slave select output
	QSPIO_SLSO2	O4		Master slave select output
	QSPIO_SCLK	O5		Master SPI clock output
	—	O6		Reserved
	CCU61_COUT62	O7		T12 PWM channel 62
	IOM_MON1_13			Monitor input 1
IOM_REF1_8	Reference input 1			
C20	P20.14	I	FAST / PU1 / VEXT / ES	General-purpose input
	GTM_TIM3_IN2_4			Mux input channel 2 of TIM module 3
	GTM_TIM2_IN2_4			Mux input channel 2 of TIM module 2
	QSPIO_MTSRA			Slave SPI data input
	IOM_PIN_15			GPIO pad input to FPC
	P20.14	O0		General-purpose output
	GTM_TOUT70	O1		GTM muxed output
	IOM_MON0_15			Monitor input 0
	—	O2		Reserved
	QSPIO_MTSR	O3		Master SPI data output
	—	O4		Reserved
	—	O5		Reserved
	—	O6		Reserved
	—	O7		Reserved

## Pin Definition and Functions BGA292 Package Variant Pin Configuration

Table 2-35 Port 21 Functions

Ball	Symbol	Ctrl.	Buffer Type	Function
K17	P21.0	I	LVDS_R X/FAST/ PU1/ VEXT/ ES	General-purpose input
	GTM_TIM4_IN0_11			Mux input channel 0 of TIM module 4
	GTM_TIM3_IN4_6			Mux input channel 4 of TIM module 3
	GTM_TIM2_IN4_6			Mux input channel 4 of TIM module 2
	QSPI4_MRSTDN			Master SPI data input (LVDS N line)
	DMU_FDEST			Enter destructive debug mode
	ASCLIN11_ARXC			Receive input
	ASCLIN17_ARXB			Receive input
	P21.0	O0	General-purpose output	
	GTM_TOUT51	O1	GTM muxed output	
	ASCLIN11_ATX	O2	Transmit output	
	—	O3	Reserved	
	—	O4	Reserved	
	—	O5	Reserved	
	—	O6	Reserved	
	—	O7	Reserved	
HSM_HSM1	O	Pin Output Value		
J17	P21.1	I	LVDS_R X/FAST/ PU1/ VEXT/ ES	General-purpose input
	GTM_TIM4_IN1_13			Mux input channel 1 of TIM module 4
	GTM_TIM3_IN5_6			Mux input channel 5 of TIM module 3
	GTM_TIM2_IN5_6			Mux input channel 5 of TIM module 2
	QSPI4_MRSTDP			Master SPI data input (LVDS P line)
	ASCLIN11_ARXD			Receive input
	ASCLIN18_ARXA			Receive input
	GTM_DTMA4_1			CDTM4_DTM4
	P21.1	O0	General-purpose output	
	GTM_TOUT52	O1	GTM muxed output	
	—	O2	Reserved	
	—	O3	Reserved	
	—	O4	Reserved	
	—	O5	Reserved	
	—	O6	Reserved	
	—	O7	Reserved	
HSM_HSM2	O	Pin Output Value		

## Pin Definition and Functions BGA292 Package Variant Pin Configuration

Table 2-35 Port 21 Functions (cont'd)

Ball	Symbol	Ctrl.	Buffer Type	Function	
K19	P21.2	I	LVDS_R X/FAST/ PU1/ VEXT/ ES	General-purpose input	
	GTM_TIM5_IN4_11			Mux input channel 4 of TIM module 5	
	GTM_TIM1_IN0_7			Mux input channel 0 of TIM module 1	
	GTM_TIM0_IN0_7			Mux input channel 0 of TIM module 0	
	QSPI2_MRSTCN			Master SPI data input (LVDS N line)	
	SCU_EMGSTOP_POR T_B			Emergency stop Port Pin B input request	
	ASCLIN3_ARXGN			Differential Receive input (low active)	
	HSCT0_RXDN			Rx data	
	QSPI4_MRSTCN			Master SPI data input (LVDS N line)	
	ASCLIN11_ARXE			Receive input	
	GTM_DTMA1_0			CDTM1_DTM4	
	P21.2			O0	General-purpose output
	GTM_TOUT53			O1	GTM muxed output
	ASCLIN3_ASLSO			O2	Slave select signal output
	—			O3	Reserved
	—			O4	Reserved
GETH_MDC	O5	MDIO clock			
—	O6	Reserved			
—	O7	Reserved			
J19	P21.3	I	LVDS_R X/FAST/ PU1/ VEXT/ ES	General-purpose input	
	GTM_TIM5_IN5_12			Mux input channel 5 of TIM module 5	
	GTM_TIM1_IN1_6			Mux input channel 1 of TIM module 1	
	GTM_TIM0_IN1_6			Mux input channel 1 of TIM module 0	
	QSPI2_MRSTCP			Master SPI data input (LVDS P line)	
	ASCLIN3_ARXGP			Differential Receive input (high active)	
	GETH_MDIOD			MDIO Input	
	HSCT0_RXDP			Rx data	
	QSPI4_MRSTCP			Master SPI data input (LVDS P line)	
	P21.3			O0	General-purpose output
	GTM_TOUT54			O1	GTM muxed output
	ASCLIN11_ASCLK			O2	Shift clock output
	ASCLIN18_ATX			O3	Transmit output
	—			O4	Reserved
	—			O5	Reserved
	—			O6	Reserved
—	O7	Reserved			
GETH_MDIO	O	MDIO Output			

## Pin Definition and Functions BGA292 Package Variant Pin Configuration

Table 2-35 Port 21 Functions (cont'd)

Ball	Symbol	Ctrl.	Buffer Type	Function
K20	P21.4	I	LVDS_TX / FAST / PU1 / VEXT / ES6	General-purpose input
	GTM_TIM5_IN6_12			Mux input channel 6 of TIM module 5
	GTM_TIM1_IN2_6			Mux input channel 2 of TIM module 1
	GTM_TIM0_IN2_6			Mux input channel 2 of TIM module 0
	ASCLIN18_ARXB			Receive input
	P21.4	O0		General-purpose output
	GTM_TOUT55	O1		GTM muxed output
	ASCLIN11_ASLSO	O2		Slave select signal output
	ASCLIN18_ATX	O3		Transmit output
	—	O4		Reserved
	—	O5		Reserved
	—	O6		Reserved
	—	O7		Reserved
HSCT0_TXDN	O	Tx data		
J20	P21.5	I	LVDS_TX / FAST / PU1 / VEXT / ES6	General-purpose input
	GTM_TIM5_IN7_11			Mux input channel 7 of TIM module 5
	GTM_TIM1_IN3_6			Mux input channel 3 of TIM module 1
	GTM_TIM0_IN3_6			Mux input channel 3 of TIM module 0
	ASCLIN11_ARXF			Receive input
	P21.5	O0		General-purpose output
	GTM_TOUT56	O1		GTM muxed output
	ASCLIN3_ASCLK	O2		Shift clock output
	ASCLIN11_ATX	O3		Transmit output
	—	O4		Reserved
	—	O5		Reserved
	—	O6		Reserved
	—	O7		Reserved
HSCT0_TXDP	O	Tx data		

## Pin Definition and Functions BGA292 Package Variant Pin Configuration

Table 2-35 Port 21 Functions (cont'd)

Ball	Symbol	Ctrl.	Buffer Type	Function
H17	P21.6/TDI	I	FAST / PD / PU2 / VEXT / ES3	<b>General-purpose input</b> PD during Reset and in DAP/DAPE or JTAG mode. After Reset release and when not in DAP/DAPE or JTAG mode: PU. In Standby mode: HighZ.
	GTM_TIM4_IN2_12			<b>Mux input channel 2 of TIM module 4</b>
	GTM_TIM1_IN4_8			<b>Mux input channel 4 of TIM module 1</b>
	GTM_TIM0_IN4_8			<b>Mux input channel 4 of TIM module 0</b>
	GPT120_T5EUDA			<b>Count direction control input of timer T5</b>
	ASCLIN3_ARXF			<b>Receive input</b>
	CBS_TGI2			<b>Trigger input</b>
	TDI			<b>JTAG Module Data Input</b>
	P21.6	O0	<b>General-purpose output</b>	
	GTM_TOUT57	O1	<b>GTM muxed output</b>	
	ASCLIN3_ASLSO	O2	<b>Slave select signal output</b>	
	—	O3	<b>Reserved</b>	
	—	O4	<b>Reserved</b>	
	—	O5	<b>Reserved</b>	
	—	O6	<b>Reserved</b>	
	GPT120_T3OUT	O7	<b>External output for overflow/underflow detection of core timer T3</b>	
CBS_TGO2	O	<b>Trigger output</b>		
DAP3	I/O	<b>DAP: DAP3 Data I/O</b>		

## Pin Definition and Functions BGA292 Package Variant Pin Configuration

Table 2-35 Port 21 Functions (cont'd)

Ball	Symbol	Ctrl.	Buffer Type	Function
H16	P21.7/TDO	I	FAST / PU2 / VEXT / ES4	General-purpose input
	GTM_TIM4_IN3_12			Mux input channel 3 of TIM module 4
	GTM_TIM1_IN5_7			Mux input channel 5 of TIM module 1
	GTM_TIM0_IN5_7			Mux input channel 5 of TIM module 0
	GPT120_T5INA			Trigger/gate input of timer T5
	CBS_TGI3			Trigger input
	GETH_RXERB			Receive Error MII
	P21.7	O0	General-purpose output	
	GTM_TOUT58	O1	GTM muxed output	
	ASCLIN3_ATX	O2	Transmit output	
	IOM_MON2_15		Monitor input 2	
	IOM_REF2_15		Reference input 2	
	ASCLIN3_ASCLK		O3	Shift clock output
	—	O4	Reserved	
	—	O5	Reserved	
	—	O6	Reserved	
	GPT120_T6OUT	O7	External output for overflow/underflow detection of core timer T6	
	CBS_TGO3	O	Trigger output	
	DAP2	I/O	DAP: DAP2 Data I/O	
TDO	O	JTAG Module Data Output		

Table 2-36 Port 22 Functions

Ball	Symbol	Ctrl.	Buffer Type	Function
P20	P22.0	I	LVDS_TX / FAST / PU1 / VEXT / ES6	General-purpose input
	GTM_TIM1_IN1_7			Mux input channel 1 of TIM module 1
	GTM_TIM0_IN1_7			Mux input channel 1 of TIM module 0
	QSPI4_MTSRB			Slave SPI data input
	ASCLIN6_ARXE			Receive input
	P22.0	O0	General-purpose output	
	GTM_TOUT47	O1	GTM muxed output	
	ASCLIN3_ATXN	O2	Differential Transmit output (low active)	
	QSPI4_MTSR	O3	Master SPI data output	
	QSPI4_SCLKN	O4	Master SPI clock output (LVDS N line)	
	MSC1_FCLN	O5	Shift-clock inverted part of the differential signal	
	—	O6	Reserved	
	ASCLIN6_ATX	O7	Transmit output	

## Pin Definition and Functions BGA292 Package Variant Pin Configuration

Table 2-36 Port 22 Functions (cont'd)

Ball	Symbol	Ctrl.	Buffer Type	Function	
P19	P22.1	I	LVDS_TX / FAST / PU1 / VEXT / ES6	General-purpose input	
	GTM_TIM1_IN0_8			Mux input channel 0 of TIM module 1	
	GTM_TIM0_IN0_8			Mux input channel 0 of TIM module 0	
	QSPI4_MRSTB			Master SPI data input	
	ASCLIN7_ARXE			Receive input	
	P22.1			O0	General-purpose output
	GTM_TOUT48			O1	GTM muxed output
	ASCLIN3_ATXP			O2	Differential Transmit output (high active)
	QSPI4_MRST			O3	Slave SPI data output
	IOM_MON2_4				Monitor input 2
	IOM_REF2_4				Reference input 2
	QSPI4_SCLKP			O4	Master SPI clock output (LVDS P line)
	MSC1_FCLP			O5	Shift-clock direct part of the differential signal
	—			O6	Reserved
ASCLIN7_ATX	O7	Transmit output			
R20	P22.2	I	LVDS_TX / FAST / PU1 / VEXT / ES6	General-purpose input	
	GTM_TIM1_IN3_7			Mux input channel 3 of TIM module 1	
	GTM_TIM0_IN3_7			Mux input channel 3 of TIM module 0	
	QSPI4_SLSIB			Slave select input	
	P22.2			O0	General-purpose output
	GTM_TOUT49			O1	GTM muxed output
	ASCLIN5_ATX			O2	Transmit output
	QSPI4_SLSO3			O3	Master slave select output
	QSPI4_MTSRN			O4	Master SPI data output (LVDS N line)
	MSC1_SON			O5	Data output - inverted part of the differential signal
	—			O6	Reserved
	—			O7	Reserved

## Pin Definition and Functions BGA292 Package Variant Pin Configuration

Table 2-36 Port 22 Functions (cont'd)

Ball	Symbol	Ctrl.	Buffer Type	Function
R19	P22.3	I	LVDS_TX / FAST / PU1 / VEXT / ES6	General-purpose input
	GTM_TIM1_IN4_4			Mux input channel 4 of TIM module 1
	GTM_TIM0_IN4_4			Mux input channel 4 of TIM module 0
	QSPI4_SCLKB			Slave SPI clock inputs
	ASCLIN5_ARXC			Receive input
	P22.3	O0	General-purpose output	
	GTM_TOUT50	O1	GTM muxed output	
	—	O2	Reserved	
	QSPI4_SCLK	O3	Master SPI clock output	
	QSPI4_MTSRP	O4	Master SPI data output (LVDS P line)	
	MSC1_SOP	O5	Data output - direct part of the differential signal	
	—	O6	Reserved	
	—	O7	Reserved	
P16	P22.4	I	SLOW / PU1 / VEXT / ES	General-purpose input
	GTM_TIM3_IN0_8			Mux input channel 0 of TIM module 3
	ASCLIN7_ARXF			Receive input
	GTM_DTMA3_0			CDTM3_DTM4
	P22.4	O0	General-purpose output	
	GTM_TOUT130	O1	GTM muxed output	
	ASCLIN4_ASLSO	O2	Slave select signal output	
	—	O3	Reserved	
	QSPI0_SLSO12	O4	Master slave select output	
	—	O5	Reserved	
	CAN13_TXD	O6	CAN transmit output node 3	
	—	O7	Reserved	
	P17	P22.5	I	SLOW / PU1 / VEXT / ES
GTM_TIM3_IN1_7		Mux input channel 1 of TIM module 3		
QSPI0_MTSRC		Slave SPI data input		
CAN13_RXDC		CAN receive input node 3		
P22.5		O0	General-purpose output	
GTM_TOUT131		O1	GTM muxed output	
ASCLIN4_ATX		O2	Transmit output	
—		O3	Reserved	
QSPI0_MTSR		O4	Master SPI data output	
—		O5	Reserved	
—		O6	Reserved	
—		O7	Reserved	

## Pin Definition and Functions BGA292 Package Variant Pin Configuration

Table 2-36 Port 22 Functions (cont'd)

Ball	Symbol	Ctrl.	Buffer Type	Function
N16	P22.6	I	SLOW / PU1 / VEXT / ES	General-purpose input
	GTM_TIM3_IN2_6			Mux input channel 2 of TIM module 3
	GTM_TIM2_IN6_14			Mux input channel 6 of TIM module 2
	QSPIO_MRSTC			Master SPI data input
	ASCLIN4_ARXC			Receive input
	P22.6	O0		General-purpose output
	GTM_TOUT132	O1		GTM muxed output
	—	O2		Reserved
	—	O3		Reserved
	QSPIO_MRST	O4		Slave SPI data output
	IOM_MON2_0			Monitor input 2
	IOM_REF2_0			Reference input 2
	CAN21_TXD	O5		CAN transmit output node 1
	—	O6		Reserved
—	O7	Reserved		
N17	P22.7	I	SLOW / PU1 / VEXT / ES	General-purpose input
	GTM_TIM3_IN3_7			Mux input channel 3 of TIM module 3
	QSPIO_SCLKC			Slave SPI clock inputs
	CAN21_RXDF			CAN receive input node 1
	P22.7	O0		General-purpose output
	GTM_TOUT133	O1		GTM muxed output
	ASCLIN4_ASCLK	O2		Shift clock output
	ASCLIN17_ATX	O3		Transmit output
	QSPIO_SCLK	O4		Master SPI clock output
	—	O5		Reserved
	—	O6		Reserved
	—	O7		Reserved

## Pin Definition and Functions BGA292 Package Variant Pin Configuration

Table 2-36 Port 22 Functions (cont'd)

Ball	Symbol	Ctrl.	Buffer Type	Function
M16	P22.8	I	SLOW / PU1 / VEXT / ES	General-purpose input
	GTM_TIM5_IN0_4			Mux input channel 0 of TIM module 5
	GTM_TIM3_IN4_7			Mux input channel 4 of TIM module 3
	QSPI0_SCLKB			Slave SPI clock inputs
	P22.8	O0		General-purpose output
	GTM_TOUT134	O1		GTM muxed output
	ASCLIN5_ASCLK	O2		Shift clock output
	—	O3		Reserved
	QSPI0_SCLK	O4		Master SPI clock output
	CAN22_TXD	O5		CAN transmit output node 2
	—	O6		Reserved
	—	O7		Reserved
M17	P22.9	I	SLOW / PU1 / VEXT / ES	General-purpose input
	GTM_TIM5_IN1_10			Mux input channel 1 of TIM module 5
	GTM_TIM3_IN5_7			Mux input channel 5 of TIM module 3
	QSPI0_MRSTB			Master SPI data input
	ASCLIN4_ARXD			Receive input
	CAN22_RXDE			CAN receive input node 2
	GTM_DTMA3_1			CDTM3_DTM4
	P22.9	O0		General-purpose output
	GTM_TOUT135	O1		GTM muxed output
	—	O2		Reserved
	—	O3		Reserved
	QSPI0_MRST	O4		Slave SPI data output
	IOM_MON2_0			Monitor input 2
	IOM_REF2_0			Reference input 2
	—			O5
	—	O6		Reserved
—	O7	Reserved		

## Pin Definition and Functions BGA292 Package Variant Pin Configuration

Table 2-36 Port 22 Functions (cont'd)

Ball	Symbol	Ctrl.	Buffer Type	Function
L16	P22.10	I	SLOW / PU1 / VEXT / ES	General-purpose input
	GTM_TIM5_IN2_8			Mux input channel 2 of TIM module 5
	GTM_TIM3_IN6_7			Mux input channel 6 of TIM module 3
	QSPI0_MTSRB			Slave SPI data input
	P22.10	O0		General-purpose output
	GTM_TOUT136	O1		GTM muxed output
	ASCLIN4_ATX	O2		Transmit output
	—	O3		Reserved
	QSPI0_MTSR	O4		Master SPI data output
	CAN23_TXD	O5		CAN transmit output node 3
	—	O6		Reserved
	—	O7		Reserved
L17	P22.11	I	SLOW / PU1 / VEXT / ES	General-purpose input
	GTM_TIM5_IN3_10			Mux input channel 3 of TIM module 5
	GTM_TIM3_IN7_7			Mux input channel 7 of TIM module 3
	CAN23_RXDE			CAN receive input node 3
	ASCLIN17_ARXA			Receive input
	P22.11	O0		General-purpose output
	GTM_TOUT137	O1		GTM muxed output
	ASCLIN4_ASLSO	O2		Slave select signal output
	ASCLIN17_ATX	O3		Transmit output
	QSPI0_SLSO10	O4		Master slave select output
	—	O5		Reserved
	—	O6		Reserved
—	O7	Reserved		

## Pin Definition and Functions BGA292 Package Variant Pin Configuration

Table 2-37 Port 23 Functions

Ball	Symbol	Ctrl.	Buffer Type	Function
V20	P23.0	I	SLOW / PU1 / VEXT / ES	<b>General-purpose input</b>
	GTM_TIM6_IN7_1			<b>Mux input channel 7 of TIM module 6</b>
	GTM_TIM1_IN5_4			<b>Mux input channel 5 of TIM module 1</b>
	GTM_TIM0_IN5_4			<b>Mux input channel 5 of TIM module 0</b>
	CAN10_RXDC			<b>CAN receive input node 0</b>
	P23.0	O0		<b>General-purpose output</b>
	GTM_TOUT41	O1		<b>GTM muxed output</b>
	—	O2		<b>Reserved</b>
	—	O3		<b>Reserved</b>
	—	O4		<b>Reserved</b>
	—	O5		<b>Reserved</b>
	—	O6		<b>Reserved</b>
	—	O7		<b>Reserved</b>
U19	P23.1	I	FAST / PU1 / VEXT / ES	<b>General-purpose input</b>
	GTM_TIM6_IN6_1			<b>Mux input channel 6 of TIM module 6</b>
	GTM_TIM1_IN6_4			<b>Mux input channel 6 of TIM module 1</b>
	GTM_TIM0_IN6_4			<b>Mux input channel 6 of TIM module 0</b>
	MSC1_SDIO			<b>Upstream asynchronous input signal</b>
	ASCLIN6_ARXF			<b>Receive input</b>
	P23.1	O0		<b>General-purpose output</b>
	GTM_TOUT42	O1		<b>GTM muxed output</b>
	ASCLIN1_ARTS	O2		<b>Ready to send output</b>
	QSPI4_SLSO6	O3		<b>Master slave select output</b>
	GTM_CLK0	O4		<b>CGM generated clock</b>
	CAN10_TXD	O5		<b>CAN transmit output node 0</b>
	CCU_EXTCLK0	O6		<b>External Clock 0</b>
ASCLIN6_ASCLK	O7	<b>Shift clock output</b>		

## Pin Definition and Functions BGA292 Package Variant Pin Configuration

Table 2-37 Port 23 Functions (cont'd)

Ball	Symbol	Ctrl.	Buffer Type	Function
U20	P23.2	I	SLOW / PU1 / VEXT / ES	General-purpose input
	GTM_TIM6_IN5_1			Mux input channel 5 of TIM module 6
	GTM_TIM1_IN6_5			Mux input channel 6 of TIM module 1
	GTM_TIM0_IN6_5			Mux input channel 6 of TIM module 0
	ASCLIN7_ARXC			Receive input
	P23.2	O0		General-purpose output
	GTM_TOUT43	O1		GTM muxed output
	—	O2		Reserved
	—	O3		Reserved
	CAN23_TXD	O4		CAN transmit output node 3
	CAN12_TXD	O5		CAN transmit output node 2
	—	O6		Reserved
	—	O7		Reserved
	T19	P23.3		I
GTM_TIM6_IN4_2		Mux input channel 4 of TIM module 6		
GTM_TIM1_IN7_4		Mux input channel 7 of TIM module 1		
GTM_TIM0_IN7_4		Mux input channel 7 of TIM module 0		
MSC1_INJ0		Injection signal from port		
ASCLIN6_ARXA		Receive input		
CAN12_RXDC		CAN receive input node 2		
CAN23_RXDB		CAN receive input node 3		
P23.3		O0	General-purpose output	
GTM_TOUT44		O1	GTM muxed output	
ASCLIN7_ATX		O2	Transmit output	
—		O3	Reserved	
—		O4	Reserved	
—		O5	Reserved	
—		O6	Reserved	
—		O7	Reserved	

## Pin Definition and Functions BGA292 Package Variant Pin Configuration

Table 2-37 Port 23 Functions (cont'd)

Ball	Symbol	Ctrl.	Buffer Type	Function
T20	P23.4	I	FAST / PU1 / VEXT / ES	General-purpose input
	GTM_TIM6_IN3_2			Mux input channel 3 of TIM module 6
	GTM_TIM1_IN7_5			Mux input channel 7 of TIM module 1
	GTM_TIM0_IN7_5			Mux input channel 7 of TIM module 0
	P23.4	O0		General-purpose output
	GTM_TOUT45	O1		GTM muxed output
	ASCLIN6_ASLSO	O2		Slave select signal output
	QSPI4_SLSO5	O3		Master slave select output
	—	O4		Reserved
	MSC1_EN0	O5		Chip Select
	—	O6		Reserved
	—	O7		Reserved
T17	P23.5	I	FAST / PU1 / VEXT / ES	General-purpose input
	GTM_TIM6_IN2_2			Mux input channel 2 of TIM module 6
	GTM_TIM1_IN2_7			Mux input channel 2 of TIM module 1
	GTM_TIM0_IN2_7			Mux input channel 2 of TIM module 0
	ASCLIN16_ARXA			Receive input
	P23.5	O0		General-purpose output
	GTM_TOUT46	O1		GTM muxed output
	ASCLIN6_ATX	O2		Transmit output
	QSPI4_SLSO4	O3		Master slave select output
	—	O4		Reserved
	MSC1_EN1	O5		Chip Select
	CAN22_TXD	O6		CAN transmit output node 2
—	O7	Reserved		
R17	P23.6	I	SLOW / PU1 / VEXT / ES	General-purpose input
	GTM_TIM6_IN1_2			Mux input channel 1 of TIM module 6
	GTM_TIM4_IN2_7			Mux input channel 2 of TIM module 4
	GTM_TIM1_IN2_10			Mux input channel 2 of TIM module 1
	CAN22_RXDC			CAN receive input node 2
	P23.6	O0		General-purpose output
	GTM_TOUT138	O1		GTM muxed output
	ASCLIN16_ATX	O2		Transmit output
	—	O3		Reserved
	QSPI0_SLSO11	O4		Master slave select output
	CAN11_TXD	O5		CAN transmit output node 1
	—	O6		Reserved
—	O7	Reserved		

## Pin Definition and Functions BGA292 Package Variant Pin Configuration

Table 2-37 Port 23 Functions (cont'd)

Ball	Symbol	Ctrl.	Buffer Type	Function
R16	P23.7	I	SLOW / PU1 / VEXT / ES	<b>General-purpose input</b>
	GTM_TIM6_IN0_2			<b>Mux input channel 0 of TIM module 6</b>
	GTM_TIM4_IN3_7			<b>Mux input channel 3 of TIM module 4</b>
	GTM_TIM1_IN3_10			<b>Mux input channel 3 of TIM module 1</b>
	CAN11_RXDC			<b>CAN receive input node 1</b>
	ASCLIN16_ARXB			<b>Receive input</b>
	P23.7	O0	<b>General-purpose output</b>	
	GTM_TOUT139	O1	<b>GTM muxed output</b>	
	ASCLIN16_ATX	O2	<b>Transmit output</b>	
	—	O3	<b>Reserved</b>	
	—	O4	<b>Reserved</b>	
	—	O5	<b>Reserved</b>	
	—	O6	<b>Reserved</b>	
	—	O7	<b>Reserved</b>	

Table 2-38 Port 32 Functions

Ball	Symbol	Ctrl.	Buffer Type	Function
Y17	P32.0	I	SLOW / PU1 / VEXT / ES	<b>General-purpose input</b> P32.0 / SMPS mode: analog output. External Pass Device gate control for EVRC
	GTM_TIM3_IN2_5			<b>Mux input channel 2 of TIM module 3</b>
	GTM_TIM2_IN2_5			<b>Mux input channel 2 of TIM module 2</b>
	P32.0	O0	<b>General-purpose output</b>	
	GTM_TOUT36	O1	<b>GTM muxed output</b>	
	—	O2	<b>Reserved</b>	
	—	O3	<b>Reserved</b>	
	—	O4	<b>Reserved</b>	
	—	O5	<b>Reserved</b>	
	—	O6	<b>Reserved</b>	
	—	O7	<b>Reserved</b>	

## Pin Definition and Functions BGA292 Package Variant Pin Configuration

Table 2-38 Port 32 Functions (cont'd)

Ball	Symbol	Ctrl.	Buffer Type	Function
W17	P32.1	I	SLOW / PU1 / VEXT / ES	<b>General-purpose input</b> P32.1 / External Pass Device gate control for EVRC
	GTM_TIM3_IN3_15			<b>Mux input channel 3 of TIM module 3</b>
	P32.1	O0		<b>General-purpose output</b>
	GTM_TOUT37	O1		<b>GTM muxed output</b>
	—	O2		<b>Reserved</b>
	—	O3		<b>Reserved</b>
	—	O4		<b>Reserved</b>
	—	O5		<b>Reserved</b>
	—	O6		<b>Reserved</b>
	—	O7		<b>Reserved</b>
Y18	P32.2	I	SLOW / PU1 / VEXT / ES	<b>General-purpose input</b>
	GTM_TIM1_IN3_8			<b>Mux input channel 3 of TIM module 1</b>
	GTM_TIM0_IN3_8			<b>Mux input channel 3 of TIM module 0</b>
	CAN03_RXDB			<b>CAN receive input node 3</b>
	ASCLIN3_ARXD			<b>Receive input</b>
	CAN21_RXDD			<b>CAN receive input node 1</b>
	P32.2			O0
	GTM_TOUT38	O1		<b>GTM muxed output</b>
	ASCLIN3_ATX	O2		<b>Transmit output</b>
	IOM_MON2_15			<b>Monitor input 2</b>
	IOM_REF2_15			<b>Reference input 2</b>
	—			O3
	—	O4		<b>Reserved</b>
	—	O5		<b>Reserved</b>
	PMS_DCDCSYNCO	O6		<b>DC-DC synchronization output</b>
—	O7	<b>Reserved</b>		

## Pin Definition and Functions BGA292 Package Variant Pin Configuration

Table 2-38 Port 32 Functions (cont'd)

Ball	Symbol	Ctrl.	Buffer Type	Function	
Y19	P32.3	I	SLOW / PU1 / VEXT / ES	General-purpose input	
	GTM_TIM1_IN4_5			Mux input channel 4 of TIM module 1	
	GTM_TIM0_IN4_5			Mux input channel 4 of TIM module 0	
	P32.3	O0		General-purpose output	
	GTM_TOUT39	O1		GTM muxed output	
	ASCLIN3_ATX	O2		Transmit output	
	IOM_MON2_15			Monitor input 2	
	IOM_REF2_15	O3		Reference input 2	
	—			Reserved	
	ASCLIN3_ASCLK			O4	Shift clock output
	CAN03_TXD	O5		CAN transmit output node 3	
	IOM_MON2_8	O6		Monitor input 2	
	IOM_REF2_8			Reference input 2	
	CAN21_TXD	O6		CAN transmit output node 1	
	—	O7		Reserved	
W18	P32.4	I	FAST / PU1 / VEXT / ES	General-purpose input	
	GTM_TIM1_IN5_5			Mux input channel 5 of TIM module 1	
	GTM_TIM0_IN5_5			Mux input channel 5 of TIM module 0	
	ASCLIN1_ACTSB			Clear to send input	
	MSC1_SDI2			Upstream asynchronous input signal	
	ASCLIN15_ARXA			O0	Receive input
	P32.4				General-purpose output
	GTM_TOUT40			O1	GTM muxed output
	PMS_DCDCSYNCO			O2	DC-DC synchronization output
	—			O3	Reserved
	GTM_CLK1			O4	CGM generated clock
	MSC1_EN0			O5	Chip Select
	CCU_EXTCLK1			O6	External Clock 1
	CCU60_COUT63			O7	T13 PWM channel 63
	IOM_MON1_6			O7	Monitor input 1
IOM_REF1_0	Reference input 1				

## Pin Definition and Functions BGA292 Package Variant Pin Configuration

Table 2-38 Port 32 Functions (cont'd)

Ball	Symbol	Ctrl.	Buffer Type	Function	
T15	P32.5	I	SLOW / PU1 / VEXT / ES	General-purpose input	
	GTM_TIM5_IN5_9			Mux input channel 5 of TIM module 5	
	GTM_TIM4_IN1_14			Mux input channel 1 of TIM module 4	
	GTM_TIM3_IN5_8			Mux input channel 5 of TIM module 3	
	SENT_SENT10C			Receive input channel 10	
	P32.5			O0	General-purpose output
	GTM_TOUT140			O1	GTM muxed output
	ASCLIN2_ATX			O2	Transmit output
	IOM_MON2_14			O3	Monitor input 2
	IOM_REF2_14				Reference input 2
	—				Reserved
	—				Reserved
	—			O4	Reserved
	—			O5	Reserved
	CAN02_TXD			O6	CAN transmit output node 2
	IOM_MON2_7			O7	Monitor input 2
IOM_REF2_7	Reference input 2				
—	Reserved				
U15	P32.6	I	SLOW / PU1 / VEXT / ES	General-purpose input	
	GTM_TIM5_IN6_9			Mux input channel 6 of TIM module 5	
	GTM_TIM4_IN4_15			Mux input channel 4 of TIM module 4	
	GTM_TIM3_IN6_8			Mux input channel 6 of TIM module 3	
	CAN02_RXDC			CAN receive input node 2	
	CBS_TGI4			Trigger input	
	ASCLIN2_ARXF			Receive input	
	ASCLIN6_ARXC			Receive input	
	SENT_SENT11C			Receive input channel 11	
	P32.6			O0	General-purpose output
	GTM_TOUT141			O1	GTM muxed output
	—			O2	Reserved
	—			O3	Reserved
	QSPI2_SLSO12			O4	Master slave select output
	CAN22_TXD			O5	CAN transmit output node 2
	—			O6	Reserved
—	O7	Reserved			
CBS_TGO4	O	Trigger output			

## Pin Definition and Functions BGA292 Package Variant Pin Configuration

Table 2-38 Port 32 Functions (cont'd)

Ball	Symbol	Ctrl.	Buffer Type	Function
U16	P32.7	I	SLOW / PU1 / VEXT / ES	General-purpose input
	GTM_TIM5_IN7_8			Mux input channel 7 of TIM module 5
	GTM_TIM4_IN0_15			Mux input channel 0 of TIM module 4
	GTM_TIM3_IN7_8			Mux input channel 7 of TIM module 3
	CBS_TGI5			Trigger input
	CAN22_RXDB			CAN receive input node 2
	SENT_SENT12C			Receive input channel 12
	ASCLIN15_ARXB			Receive input
	P32.7			O0
	GTM_TOUT142	O1	GTM muxed output	
	ASCLIN6_ATX	O2	Transmit output	
	—	O3	Reserved	
	ASCLIN15_ATX	O4	Transmit output	
	—	O5	Reserved	
	—	O6	Reserved	
	—	O7	Reserved	
	CBS_TGO5	O	Trigger output	

## Pin Definition and Functions BGA292 Package Variant Pin Configuration

Table 2-39 Port 33 Functions

Ball	Symbol	Ctrl.	Buffer Type	Function
W10	P33.0	I	SLOW / PU1 / VEVRSB / ES5	<b>General-purpose input</b>
	GTM_TIM3_IN0_13			<b>Mux input channel 0 of TIM module 3</b>
	GTM_TIM1_IN4_6			<b>Mux input channel 4 of TIM module 1</b>
	GTM_TIM0_IN4_6			<b>Mux input channel 4 of TIM module 0</b>
	EDSADC_ITR0E			<b>Trigger/Gate input, channel 0</b>
	SENT_SENT13C			<b>Receive input channel 13</b>
	IOM_PIN_0			<b>GPIO pad input to FPC</b>
	GTM_DTMT1_2			<b>CDTM1_DTM0</b>
	EVADC_G10CH7			AI
	P33.0	O0	<b>General-purpose output</b>	
	GTM_TOUT22	O1	<b>GTM muxed output</b>	
	IOM_MON0_0		<b>Monitor input 0</b>	
	IOM_GTM_0		<b>GTM-provided inputs to EXOR combiner</b>	
	ASCLIN5_ATX	O2	<b>Transmit output</b>	
	—	O3	<b>Reserved</b>	
	ASCLIN15_ATX	O4	<b>Transmit output</b>	
	—	O5	<b>Reserved</b>	
	EVADC_FC2BFLOUT	O6	<b>Boundary flag output, FC channel 2</b>	
	—	O7	<b>Reserved</b>	

## Pin Definition and Functions BGA292 Package Variant Pin Configuration

Table 2-39 Port 33 Functions (cont'd)

Ball	Symbol	Ctrl.	Buffer Type	Function
Y10	P33.1	I	SLOW / PU1 / VEVRSB / ES5	General-purpose input
	GTM_TIM3_IN1_15			Mux input channel 1 of TIM module 3
	GTM_TIM1_IN5_6			Mux input channel 5 of TIM module 1
	GTM_TIM0_IN5_6			Mux input channel 5 of TIM module 0
	EDSADC_ITR1E			Trigger/Gate input, channel 1
	PSI5_RX0C			RXD inputs (receive data) channel 0
	EDSADC_DSCIN2B			Modulator clock input, channel 2
	SENT_SENT9C			Receive input channel 9
	ASCLIN8_ARXC			Receive input
	IOM_PIN_1			GPIO pad input to FPC
	EVADC_G10CH6			AI
	P33.1	O0	General-purpose output	
	GTM_TOUT23	O1	GTM muxed output	
	IOM_MON0_1		Monitor input 0	
	IOM_GTM_1	GTM-provided inputs to EXOR combiner		
	ASCLIN3_ASLSO	O2	Slave select signal output	
	QSPI2_SCLK	O3	Master SPI clock output	
	EDSADC_DSCOUT2	O4	Modulator clock output	
	EVADC_EMUX02	O5	Control of external analog multiplexer interface 0	
	—	O6	Reserved	
—	O7	Reserved		

## Pin Definition and Functions BGA292 Package Variant Pin Configuration

Table 2-39 Port 33 Functions (cont'd)

Ball	Symbol	Ctrl.	Buffer Type	Function
W11	P33.2	I	SLOW / PU1 / VEVRSB / ES5	General-purpose input
	GTM_TIM3_IN2_14			Mux input channel 2 of TIM module 3
	GTM_TIM1_IN6_6			Mux input channel 6 of TIM module 1
	GTM_TIM0_IN6_6			Mux input channel 6 of TIM module 0
	EDSADC_ITR2E			Trigger/Gate input, channel 2
	SENT_SENT8C			Receive input channel 8
	EDSADC_DSDIN2B			Digital datastream input, channel 2
	IOM_PIN_2			GPIO pad input to FPC
	EVADC_G10CH5	AI	Analog input channel 5, group 10	
	P33.2	O0	General-purpose output	
	GTM_TOUT24	O1	GTM muxed output	
	IOM_MON0_2		Monitor input 0	
	IOM_GTM_2		GTM-provided inputs to EXOR combiner	
	ASCLIN3_ASCLK	O2	Shift clock output	
	QSPI2_SLSO10	O3	Master slave select output	
	PSI5_TX0	O4	TXD outputs (send data)	
	IOM_MON1_14		Monitor input 1	
	IOM_REF1_14		Reference input 1	
	EVADC_EMUX01	O5	Control of external analog multiplexer interface 0	
	EVADC_FC3BFLOUT	O6	Boundary flag output, FC channel 3	
ASCLIN14_ATX	O7	Transmit output		

## Pin Definition and Functions BGA292 Package Variant Pin Configuration

Table 2-39 Port 33 Functions (cont'd)

Ball	Symbol	Ctrl.	Buffer Type	Function
Y11	P33.3	I	SLOW / PU1 / VEVRSB / ES5	General-purpose input
	GTM_TIM3_IN3_12			Mux input channel 3 of TIM module 3
	GTM_TIM1_IN7_6			Mux input channel 7 of TIM module 1
	GTM_TIM0_IN7_6			Mux input channel 7 of TIM module 0
	PSI5_RX1C			RXD inputs (receive data) channel 1
	SENT_SENT7C			Receive input channel 7
	EDSADC_DSCIN1B			Modulator clock input, channel 1
	ASCLIN14_ARXA			Receive input
	IOM_PIN_3			GPIO pad input to FPC
	EVADC_G10CH4			Analog input channel 4, group 10
	P33.3	O0	General-purpose output	
	GTM_TOUT25	O1	GTM muxed output	
	IOM_MON0_3		Monitor input 0	
	IOM_GTM_3		GTM-provided inputs to EXOR combiner	
	ASCLIN5_ASCLK	O2	Shift clock output	
	QSPI4_SLSO2	O3	Master slave select output	
	EDSADC_DSCOUT1	O4	Modulator clock output	
	EVADC_EMUX00	O5	Control of external analog multiplexer interface 0	
	—	O6	Reserved	
	ASCLIN14_ATX	O7	Transmit output	

## Pin Definition and Functions BGA292 Package Variant Pin Configuration

Table 2-39 Port 33 Functions (cont'd)

Ball	Symbol	Ctrl.	Buffer Type	Function
W12	P33.4	I	SLOW / PU1 / VEVRSB / ES5	General-purpose input
	GTM_TIM4_IN4_10			Mux input channel 4 of TIM module 4
	GTM_TIM1_IN0_10			Mux input channel 0 of TIM module 1
	GTM_TIM0_IN0_10			Mux input channel 0 of TIM module 0
	EDSADC_ITR0F			Trigger/Gate input, channel 0
	SENT_SENT6C			Receive input channel 6
	EDSADC_DSDIN1B			Digital datastream input, channel 1
	CCU61_CTRAPC			Trap input capture
	ASCLIN5_ARXB			Receive input
	ASCLIN14_ARXB			Receive input
	IOM_PIN_4			GPIO pad input to FPC
	GTM_DTMT2_0			CDTM2_DTM0
	EVADC_G10CH3			AI
	P33.4	O0	General-purpose output	
	GTM_TOUT26	O1	GTM muxed output	
	IOM_MON0_4		Monitor input 0	
	IOM_GTM_4		GTM-provided inputs to EXOR combiner	
	ASCLIN2_ARTS	O2	Ready to send output	
	QSPI2_SLSO12	O3	Master slave select output	
	PSI5_TX1	O4	TXD outputs (send data)	
IOM_MON1_15		Monitor input 1		
EVADC_EMUX12	O5	Control of external analog multiplexer interface 1		
EVADC_FC0BFLOUT	O6	Boundary flag output, FC channel 0		
CAN13_TXD	O7	CAN transmit output node 3		

## Pin Definition and Functions BGA292 Package Variant Pin Configuration

Table 2-39 Port 33 Functions (cont'd)

Ball	Symbol	Ctrl.	Buffer Type	Function
Y12	P33.5	I	SLOW / PU1 / VEVRSB / ES5	General-purpose input
	GTM_TIM4_IN5_10			Mux input channel 5 of TIM module 4
	GTM_TIM1_IN1_8			Mux input channel 1 of TIM module 1
	GTM_TIM0_IN1_8			Mux input channel 1 of TIM module 0
	EDSADC_DSCIN0B			Modulator clock input, channel 0
	EDSADC_ITR1F			Trigger/Gate input, channel 1
	GPT120_T4EADB			Count direction control input of timer T4
	PSI5S_RXC			RX data input
	ASCLIN2_ACTSB			Clear to send input
	CCU61_CCPOS2C			Hall capture input 2
	PSI5_RX2C			RXD inputs (receive data) channel 2
	SENT_SENT5C			Receive input channel 5
	CAN13_RXDB			CAN receive input node 3
	IOM_PIN_5			GPIO pad input to FPC
	EVADC_G10CH2	AI	Analog input channel 2, group 10	
	P33.5	O0	General-purpose output	
	GTM_TOUT27	O1	GTM muxed output	
	IOM_MON0_5		Monitor input 0	
	IOM_GTM_5		GTM-provided inputs to EXOR combiner	
	QSPIO_SLSO7	O2	Master slave select output	
QSPI1_SLSO7	O3	Master slave select output		
EDSADC_DSCOUT0	O4	Modulator clock output		
EVADC_EMUX11	O5	Control of external analog multiplexer interface 1		
EVADC_FC2BFLOUT	O6	Boundary flag output, FC channel 2		
ASCLIN5_ASLSO	O7	Slave select signal output		

## Pin Definition and Functions BGA292 Package Variant Pin Configuration

Table 2-39 Port 33 Functions (cont'd)

Ball	Symbol	Ctrl.	Buffer Type	Function	
W13	P33.6	I	SLOW / PU1 / VEVRSB / ES5	General-purpose input	
	GTM_TIM1_IN2_9			Mux input channel 2 of TIM module 1	
	GTM_TIM0_IN2_9			Mux input channel 2 of TIM module 0	
	EDSADC_ITR2F			Trigger/Gate input, channel 2	
	GPT120_T2EUDB			Count direction control input of timer T2	
	SENT_SENT4C			Receive input channel 4	
	CCU61_CCPOS1C			Hall capture input 1	
	EDSADC_DSDIN0B			Digital datastream input, channel 0	
	ASCLIN8_ARXD			Receive input	
	IOM_PIN_6			GPIO pad input to FPC	
	GTM_DTMT2_1			CDTM2_DTM0	
	EVADC_G10CH1			AI	Analog input channel 1, group 10
	P33.6			O0	General-purpose output
	GTM_TOUT28	O1	GTM muxed output		
	IOM_MON0_6		Monitor input 0		
	IOM_GTM_6		GTM-provided inputs to EXOR combiner		
	ASCLIN2_ASLSO	O2	Slave select signal output		
	QSPI2_SLSO11	O3	Master slave select output		
	PSI5_TX2	O4	TXD outputs (send data)		
	IOM_REF1_15	O5	Reference input 1		
EVADC_EMUX10	Control of external analog multiplexer interface 1				
EVADC_FC1BFLOUT	O6		Boundary flag output, FC channel 1		
PSI5S_TX	O7	TX data output			

## Pin Definition and Functions BGA292 Package Variant Pin Configuration

Table 2-39 Port 33 Functions (cont'd)

Ball	Symbol	Ctrl.	Buffer Type	Function
Y13	P33.7	I	SLOW / PU1 / VEVRSB / ES5	General-purpose input
	GTM_TIM1_IN3_9			Mux input channel 3 of TIM module 1
	GTM_TIM0_IN3_9			Mux input channel 3 of TIM module 0
	CAN00_RXDE			CAN receive input node 0
	GPT120_T2INB			Trigger/gate input of timer T2
	CCU61_CCPOS0C			Hall capture input 0
	SCU_E_REQ4_0			ERU Channel 4 inputs 0 to 5 (0 is the LSB and 5 is the MSB)
	SENT_SENT14C			Receive input channel 14
	IOM_PIN_7			GPIO pad input to FPC
	EVADC_G10CH0			Analog input channel 0, group 10
	P33.7	O0	General-purpose output	
	GTM_TOUT29	O1	GTM muxed output	
	IOM_MON0_7	O1	Monitor input 0	
	IOM_GTM_7		GTM-provided inputs to EXOR combiner	
	ASCLIN2_ASCLK	O2	Shift clock output	
	QSPI4_SLSO7	O3	Master slave select output	
	ASCLIN8_ATX	O4	Transmit output	
	—	O5	Reserved	
	EVADC_FC3BFLOUT	O6	Boundary flag output, FC channel 3	
	—	O7	Reserved	

## Pin Definition and Functions BGA292 Package Variant Pin Configuration

Table 2-39 Port 33 Functions (cont'd)

Ball	Symbol	Ctrl.	Buffer Type	Function
W14	P33.8	I	FAST / HighZ / VEVR SB	General-purpose input
	GTM_TIM1_IN4_7			Mux input channel 4 of TIM module 1
	GTM_TIM0_IN4_7			Mux input channel 4 of TIM module 0
	ASCLIN2_ARXE			Receive input
	SCU_EMGSTOP_PORT_A			Emergency stop Port Pin A input request
	IOM_PIN_8			GPIO pad input to FPC
	P33.8	O0	General-purpose output	
	GTM_TOUT30	O1	GTM muxed output	
	IOM_MON0_8	O2	Monitor input 0	
	ASCLIN2_ATX		Transmit output	
	IOM_MON2_14		Monitor input 2	
	IOM_REF2_14	Reference input 2		
	QSPI4_SLSO2	O3	Master slave select output	
	—	O4	Reserved	
	CAN00_TXD	O5	CAN transmit output node 0	
	IOM_MON2_5	O6	Monitor input 2	
	IOM_REF2_5		Reference input 2	
	—		Reserved	
	CCU61_COUT62	O7	T12 PWM channel 62	
	IOM_MON1_13	O	Monitor input 1	
IOM_REF1_8	Reference input 1			
SMU_FSP0		FSP[1..0] Output Signals - Generated by SMU_core		

## Pin Definition and Functions BGA292 Package Variant Pin Configuration

Table 2-39 Port 33 Functions (cont'd)

Ball	Symbol	Ctrl.	Buffer Type	Function
Y14	P33.9	I	SLOW / PU1 / VEVRSB / ES5	General-purpose input
	GTM_TIM1_IN1_9			Mux input channel 1 of TIM module 1
	GTM_TIM0_IN1_9			Mux input channel 1 of TIM module 0
	IOM_PIN_9			GPIO pad input to FPC
	P33.9	O0	SLOW / PU1 / VEVRSB / ES5	General-purpose output
	GTM_TOUT31	O1		GTM muxed output
	IOM_MON0_9	O2		Monitor input 0
	ASCLIN2_ATX			Transmit output
	IOM_MON2_14			Monitor input 2
	IOM_REF2_14	O3		Reference input 2
	QSPI4_SLSO1			Master slave select output
	ASCLIN2_ASCLK	O4		Shift clock output
	CAN01_TXD	O5		CAN transmit output node 1
	IOM_MON2_6			Monitor input 2
	IOM_REF2_6			Reference input 2
	ASCLIN0_ATX	O6		Transmit output
	IOM_MON2_12			Monitor input 2
	IOM_REF2_12			Reference input 2
	CCU61_CC62	O7		T12 PWM channel 62
	IOM_MON1_10			Monitor input 1
IOM_REF1_11	Reference input 1			

## Pin Definition and Functions BGA292 Package Variant Pin Configuration

Table 2-39 Port 33 Functions (cont'd)

Ball	Symbol	Ctrl.	Buffer Type	Function
W15	P33.10	I	FAST / PU1 / VEVRSB / ES5	General-purpose input
	GTM_TIM4_IN4_14			Mux input channel 4 of TIM module 4
	GTM_TIM1_IN0_9			Mux input channel 0 of TIM module 1
	GTM_TIM0_IN0_9			Mux input channel 0 of TIM module 0
	QSPI4_SLSIA			Slave select input
	CAN01_RXDD			CAN receive input node 1
	ASCLIN0_ARXD			Receive input
	IOM_PIN_10			GPIO pad input to FPC
	P33.10	O0	General-purpose output	
	GTM_TOUT32	O1	GTM muxed output	
	IOM_MON0_10		Monitor input 0	
	QSPI1_SLSO6	O2	Master slave select output	
	QSPI4_SLSO0	O3	Master slave select output	
	ASCLIN1_ASLSO	O4	Slave select signal output	
	PSI5S_CLK	O5	PSI5S CLK is a clock that can be used on a pin to drive the external PHY.	
	—	O6	Reserved	
	CCU61_COUT61	O7	T12 PWM channel 61	
	IOM_MON1_12		Monitor input 1	
IOM_REF1_9		Reference input 1		
SMU_FSP1	O	FSP[1..0] Output Signals - Generated by SMU_core		
Y15	P33.11	I	FAST / PU1 / VEVRSB / ES5	General-purpose input
	GTM_TIM1_IN2_8			Mux input channel 2 of TIM module 1
	GTM_TIM0_IN2_8			Mux input channel 2 of TIM module 0
	QSPI4_SCLKA			Slave SPI clock inputs
	IOM_PIN_11			GPIO pad input to FPC
	P33.11	O0	General-purpose output	
	GTM_TOUT33	O1	GTM muxed output	
	IOM_MON0_11		Monitor input 0	
	ASCLIN1_ASCLK	O2	Shift clock output	
	QSPI4_SCLK	O3	Master SPI clock output	
	—	O4	Reserved	
	—	O5	Reserved	
	EDSADC_CGPWMN	O6	Negative carrier generator output	
	CCU61_CC61	O7	T12 PWM channel 61	
	IOM_MON1_9		Monitor input 1	
IOM_REF1_12		Reference input 1		

## Pin Definition and Functions BGA292 Package Variant Pin Configuration

Table 2-39 Port 33 Functions (cont'd)

Ball	Symbol	Ctrl.	Buffer Type	Function
W16	P33.12	I	FAST / PU1 / VEVRSB / ES5	General-purpose input
	GTM_TIM3_IN0_6			Mux input channel 0 of TIM module 3
	GTM_TIM2_IN0_6			Mux input channel 0 of TIM module 2
	QSPI4_MTSRA			Slave SPI data input
	CAN00_RXDD			CAN receive input node 0
	PMS_PINBWKP			PINB (P33.12) pin input
	IOM_PIN_12			GPIO pad input to FPC
	P33.12	O0	General-purpose output	
	GTM_TOUT34	O1	GTM muxed output	
	IOM_MON0_12	O2	Monitor input 0	
	ASCLIN1_ATX		Transmit output	
	IOM_MON2_13		Monitor input 2	
	IOM_REF2_13	O3	Reference input 2	
	QSPI4_MTSR		Master SPI data output	
	ASCLIN1_ASCLK	O4	Shift clock output	
	CAN22_TXD	O5	CAN transmit output node 2	
	EDSADC_CGPWMP	O6	Positive carrier generator output	
	CCU61_COUT60	O7	T12 PWM channel 60	
	IOM_MON1_11		Monitor input 1	
	IOM_REF1_10		Reference input 1	

## Pin Definition and Functions BGA292 Package Variant Pin Configuration

Table 2-39 Port 33 Functions (cont'd)

Ball	Symbol	Ctrl.	Buffer Type	Function
Y16	P33.13	I	FAST / PU1 / VEVRSB / ES5	General-purpose input
	GTM_TIM3_IN1_5			Mux input channel 1 of TIM module 3
	GTM_TIM2_IN1_5			Mux input channel 1 of TIM module 2
	ASCLIN1_ARXF			Receive input
	EDSADC_SGNB			Carrier sign signal input
	QSPI4_MRSTA			Master SPI data input
	MSC1_INJ1			Injection signal from port
	CAN22_RXDA			CAN receive input node 2
	P33.13			O0
	GTM_TOUT35	O1	GTM muxed output	
	ASCLIN1_ATX	O2	Transmit output	
	IOM_MON2_13		Monitor input 2	
	IOM_REF2_13		Reference input 2	
	QSPI4_MRST		O3	Slave SPI data output
	IOM_MON2_4		Monitor input 2	
	IOM_REF2_4		Reference input 2	
	QSPI2_SLSO6	O4	Master slave select output	
	CAN00_TXD	O5	CAN transmit output node 0	
	IOM_MON2_5		Monitor input 2	
	IOM_REF2_5		Reference input 2	
	—	O6	Reserved	
	CCU61_CC60	O7	T12 PWM channel 60	
	IOM_MON1_8		Monitor input 1	
	IOM_REF1_13		Reference input 1	

## Pin Definition and Functions BGA292 Package Variant Pin Configuration

Table 2-39 Port 33 Functions (cont'd)

Ball	Symbol	Ctrl.	Buffer Type	Function
T14	P33.14	I	FAST / PU1 / VEVRSB / ES5	General-purpose input
	GTM_TIM5_IN0_8			Mux input channel 0 of TIM module 5
	GTM_TIM4_IN5_14			Mux input channel 5 of TIM module 4
	GTM_TIM2_IN0_8			Mux input channel 0 of TIM module 2
	QSPI2_SCLKD			Slave SPI clock inputs
	CBS_TGI6			Trigger input
	P33.14	O0	SLOW / PU1 / VEVRSB / ES5	General-purpose output
	GTM_TOUT143	O1		GTM muxed output
	—	O2		Reserved
	QSPI2_SCLK	O3		Master SPI clock output
	—	O4		Reserved
	—	O5		Reserved
	—	O6		Reserved
	CCU60_CC62	O7		T12 PWM channel 62
	IOM_MON1_0	O		Monitor input 1
	IOM_REF1_4			Reference input 1
CBS_TGO6	O	Trigger output		
U14	P33.15	I	SLOW / PU1 / VEVRSB / ES5	General-purpose input
	GTM_TIM5_IN1_9			Mux input channel 1 of TIM module 5
	GTM_TIM4_IN6_12			Mux input channel 6 of TIM module 4
	GTM_TIM2_IN1_7			Mux input channel 1 of TIM module 2
	CBS_TGI7			Trigger input
	P33.15	O0	SLOW / PU1 / VEVRSB / ES5	General-purpose output
	GTM_TOUT144	O1		GTM muxed output
	—	O2		Reserved
	QSPI2_SLSO11	O3		Master slave select output
	—	O4		Reserved
	—	O5		Reserved
	—	O6		Reserved
	CCU60_COUT62	O7		T12 PWM channel 62
	IOM_MON1_5	O		Monitor input 1
	IOM_REF1_1			Reference input 1
	CBS_TGO7	O	Trigger output	

## Pin Definition and Functions BGA292 Package Variant Pin Configuration

Table 2-40 Port 34 Functions

Ball	Symbol	Ctrl.	Buffer Type	Function
U11	P34.1	I	SLOW / PU1 / VEVR SB / ES5	<b>General-purpose input</b>
	GTM_TIM5_IN3_9			<b>Mux input channel 3 of TIM module 5</b>
	GTM_TIM3_IN4_12			<b>Mux input channel 4 of TIM module 3</b>
	GTM_TIM2_IN3_9			<b>Mux input channel 3 of TIM module 2</b>
	EVADC_G10CH11	AI		<b>Analog input channel 11, group 10</b>
	P34.1	O0		<b>General-purpose output</b>
	GTM_TOUT146	O1		<b>GTM muxed output</b>
	ASCLIN4_ATX	O2		<b>Transmit output</b>
	—	O3		<b>Reserved</b>
	CAN00_TXD	O4		<b>CAN transmit output node 0</b>
	IOM_MON2_5			<b>Monitor input 2</b>
	IOM_REF2_5			<b>Reference input 2</b>
	CAN20_TXD	O5		<b>CAN transmit output node 0</b>
	—	O6		<b>Reserved</b>
	CCU60_COUT63	O7		<b>T13 PWM channel 63</b>
IOM_MON1_6	<b>Monitor input 1</b>			
IOM_REF1_0	<b>Reference input 1</b>			
T12	P34.2	I	SLOW / PU1 / VEVR SB / ES	<b>General-purpose input</b>
	GTM_TIM5_IN4_9			<b>Mux input channel 4 of TIM module 5</b>
	GTM_TIM3_IN5_13			<b>Mux input channel 5 of TIM module 3</b>
	GTM_TIM2_IN4_8			<b>Mux input channel 4 of TIM module 2</b>
	ASCLIN4_ARXB			<b>Receive input</b>
	CAN00_RXDG			<b>CAN receive input node 0</b>
	CAN20_RXDC			<b>CAN receive input node 0</b>
	EVADC_G10CH10	AI		<b>Analog input channel 10, group 10</b>
	P34.2	O0		<b>General-purpose output</b>
	GTM_TOUT147	O1		<b>GTM muxed output</b>
	—	O2		<b>Reserved</b>
	—	O3		<b>Reserved</b>
	—	O4		<b>Reserved</b>
	—	O5		<b>Reserved</b>
	—	O6		<b>Reserved</b>
CCU60_CC60	O7	<b>T12 PWM channel 60</b>		
IOM_MON1_2		<b>Monitor input 1</b>		
IOM_REF1_6		<b>Reference input 1</b>		

## Pin Definition and Functions BGA292 Package Variant Pin Configuration

Table 2-40 Port 34 Functions (cont'd)

Ball	Symbol	Ctrl.	Buffer Type	Function
U12	P34.3	I	SLOW / PU1 / VEVRSB / ES	General-purpose input
	GTM_TIM5_IN5_10			Mux input channel 5 of TIM module 5
	GTM_TIM3_IN6_13			Mux input channel 6 of TIM module 3
	GTM_TIM2_IN5_9			Mux input channel 5 of TIM module 2
	EVADC_G10CH9	AI		Analog input channel 9, group 10
	P34.3	O0		General-purpose output
	GTM_TOUT148	O1		GTM muxed output
	ASCLIN4_ASCLK	O2		Shift clock output
	—	O3		Reserved
	QSPI2_SLSO10	O4		Master slave select output
	—	O5		Reserved
	—	O6		Reserved
	CCU60_COUT60	O7		T12 PWM channel 60
	IOM_MON1_3			Monitor input 1
IOM_REF1_3	Reference input 1			
T13	P34.4	I	SLOW / PU1 / VEVRSB / ES	General-purpose input
	GTM_TIM5_IN6_10			Mux input channel 6 of TIM module 5
	GTM_TIM3_IN7_12			Mux input channel 7 of TIM module 3
	GTM_TIM2_IN6_8			Mux input channel 6 of TIM module 2
	QSPI2_MRSTD			Master SPI data input
	EVADC_G10CH8	AI		Analog input channel 8, group 10
	P34.4	O0		General-purpose output
	GTM_TOUT149	O1		GTM muxed output
	ASCLIN4_ASLSO	O2		Slave select signal output
	—	O3		Reserved
	QSPI2_MRST	O4		Slave SPI data output
	IOM_MON2_2			Monitor input 2
	IOM_REF2_2			Reference input 2
	—	O5		Reserved
	—	O6		Reserved
	CCU60_CC61	O7		T12 PWM channel 61
	IOM_MON1_1			Monitor input 1
IOM_REF1_5	Reference input 1			

## Pin Definition and Functions BGA292 Package Variant Pin Configuration

Table 2-40 Port 34 Functions (cont'd)

Ball	Symbol	Ctrl.	Buffer Type	Function
U13	P34.5	I	FAST / PU1 / VEVRSB / ES	General-purpose input
	GTM_TIM5_IN7_9			Mux input channel 7 of TIM module 5
	GTM_TIM4_IN7_12			Mux input channel 7 of TIM module 4
	GTM_TIM2_IN7_9			Mux input channel 7 of TIM module 2
	QSPI2_MTSRD			Slave SPI data input
	ASCLIN8_ARXE			Receive input
	P34.5	O0		General-purpose output
	GTM_TOUT150	O1		GTM muxed output
	ASCLIN8_ATX	O2		Transmit output
	—	O3		Reserved
	QSPI2_MTSR	O4		Master SPI data output
	—	O5		Reserved
	—	O6		Reserved
	CCU60_COUT61	O7		T12 PWM channel 61
IOM_MON1_4		Monitor input 1		
IOM_REF1_2		Reference input 1		

Table 2-41 Analog Inputs

Ball	Symbol	Ctrl.	Buffer Type	Function
T10	AN0	I	D / HighZ / VDDM	Analog Input 0
	EVADC_G0CH0			Analog input channel 0, group 0
	EDSADC_EDS3PA			Positive analog input channel 3, pin A
U10	AN1	I	D / HighZ / VDDM	Analog Input 1
	EVADC_G0CH1			Analog input channel 1, group 0
	EDSADC_EDS3NA			Negative analog input channel 3, pin A
W9	AN2	I	D / HighZ / VDDM	Analog Input 2
	EVADC_G0CH2			Analog input channel 2, group 0
	EDSADC_EDS0PA			Positive analog input channel 0, pin A
U9	AN3	I	D / HighZ / VDDM	Analog Input 3
	EVADC_G0CH3			Analog input channel 3, group 0
	EDSADC_EDS0NA			Negative analog input channel 0, pin A
T9	AN4	I	D / HighZ / VDDM	Analog Input 4
	EVADC_G11CH0			Analog input channel 0, group 11
	EVADC_G0CH4			Analog input channel 4, group 0
Y9	AN5	I	D / HighZ / VDDM	Analog Input 5
	EVADC_G11CH1			Analog input channel 1, group 11
	EVADC_G0CH5			Analog input channel 5, group 0

## Pin Definition and Functions BGA292 Package Variant Pin Configuration

Table 2-41 Analog Inputs (cont'd)

Ball	Symbol	Ctrl.	Buffer Type	Function
T8	AN6	I	D / HighZ / VDDM	Analog Input 6
	EVADC_G11CH2			Analog input channel 2, group 11
	EVADC_G0CH6			Analog input channel 6, group 0
U8	AN7	I	D / HighZ / VDDM	Analog Input 7
	EVADC_G11CH3			Analog input channel 3, group 11
	EVADC_G0CH7			Analog input channel 7, group 0
W8	AN8	I	D / HighZ / VDDM	Analog Input 8
	EVADC_G11CH4			Analog input channel 4, group 11
	EVADC_G1CH0			Analog input channel 0, group 1
U7	AN9	I	D / HighZ / VDDM	Analog Input 9
	EVADC_G11CH5			Analog input channel 5, group 11
	EVADC_G1CH1			Analog input channel 1, group 1
Y8	AN10	I	D / HighZ / VDDM	Analog Input 10
	EVADC_G11CH6			Analog input channel 6, group 11
	EVADC_G1CH2			Analog input channel 2, group 1
W7	AN11	I	D / HighZ / VDDM	Analog Input 11
	EVADC_G11CH7			Analog input channel 7, group 11
	EVADC_G1CH3			Analog input channel 3, group 1
T7	AN12	I	D / HighZ / VDDM	Analog Input 12
	EVADC_G1CH4			Analog input channel 4, group 1
	EDSADC_EDS0PB			Positive analog input channel 0, pin B
W6	AN13	I	D / HighZ / VDDM	Analog Input 13
	EVADC_G1CH5			Analog input channel 5, group 1
	EDSADC_EDS0NB			Negative analog input channel 0, pin B
U6	AN14	I	D / HighZ / VDDM	Analog Input 14
	EVADC_G1CH6			Analog input channel 6, group 1
	EDSADC_EDS3PB			Positive analog input channel 3, pin B
T6	AN15	I	D / HighZ / VDDM	Analog Input 15
	EVADC_G1CH7			Analog input channel 7, group 1
	EDSADC_EDS3NB			Negative analog input channel 3, pin N
W5	AN16	I	D / HighZ / VDDM	Analog Input 16
	EVADC_G2CH0			Analog input channel 0, group 2
	EVADC_FC0CH0			Analog input FC channel 0
U5	AN17/P40.10	I	S / HighZ / VDDM	Analog Input 17
	SENT_SENT10A			Receive input channel 10
	EVADC_G2CH1			Analog input channel 1, group 2
	EVADC_FC1CH0			Analog input FC channel 1

## Pin Definition and Functions BGA292 Package Variant Pin Configuration

Table 2-41 Analog Inputs (cont'd)

Ball	Symbol	Ctrl.	Buffer Type	Function
W4	AN18/P40.11	I	S / HighZ / VDDM	Analog Input 18
	SENT_SENT11A			Receive input channel 11
	EVADC_G11CH8			Analog input channel 8, group 11
	EVADC_G2CH2			Analog input channel 2, group 2
W3	AN19/P40.12	I	S / HighZ / VDDM	Analog Input 19
	SENT_SENT12A			Receive input channel 12
	EVADC_G11CH9			Analog input channel 9, group 11
	EVADC_G2CH3			Analog input channel 3, group 2
Y3	AN20	I	D / HighZ / VDDM	Analog Input 20
	EVADC_G2CH4			Analog input channel 4, group 2
	EDSADC_EDS2PA			Positive analog input channel 2, pin A
Y2	AN21	I	D / HighZ / VDDM	Analog Input 21
	EVADC_G2CH5			Analog input channel 5, group 2
	EDSADC_EDS2NA			Negative analog input channel 2, pin A
T5	AN22	I	D / HighZ / VDDM	Analog Input 22
	EVADC_G2CH6			Analog input channel 6, group 2
R5	AN23	I	D / HighZ / VDDM	Analog Input 23
	EVADC_G2CH7			Analog input channel 7, group 2
W2	AN24/P40.0	I	S / HighZ / VDDM	Analog Input 24
	SENT_SENT0A			Receive input channel 0
	EVADC_G3CH0			Analog input channel 0, group 3
	CCU60_CCPOS0D			Hall capture input 0
	EDSADC_EDS2PB			Positive analog input channel 2, pin B
W1	AN25/P40.1	I	S / HighZ / VDDM	Analog Input 25
	SENT_SENT1A			Receive input channel 1
	EVADC_G3CH1			Analog input channel 1, group 3
	CCU60_CCPOS1B			Hall capture input 1
	EDSADC_EDS2NB			Negative analog input channel 2, pin B
V2	AN26/P40.2	I	S / HighZ / VDDM	Analog Input 26
	SENT_SENT2A			Receive input channel 2
	EVADC_G3CH2			Analog input channel 2, group 3
	CCU60_CCPOS1D			Hall capture input 1
	EVADC_G11CH10			Analog input channel 10, group 11
V1	AN27/P40.3	I	S / HighZ / VDDM	Analog Input 27
	SENT_SENT3A			Receive input channel 3
	EVADC_G3CH3			Analog input channel 3, group 3
	CCU60_CCPOS2B			Hall capture input 2
	EVADC_G11CH11			Analog input channel 11, group 11

## Pin Definition and Functions BGA292 Package Variant Pin Configuration

Table 2-41 Analog Inputs (cont'd)

Ball	Symbol	Ctrl.	Buffer Type	Function
U2	AN28/P40.13	I	S / HighZ / VDDM	Analog Input 28
	SENT_SENT13A			Receive input channel 13
	EVADC_G3CH4			Analog input channel 4, group 3
	EVADC_G4CH4			Analog input channel 4, group 4
U1	AN29/P40.14	I	S / HighZ / VDDM	Analog Input 29
	SENT_SENT14A			Receive input channel 14
	EVADC_G3CH5			Analog input channel 5, group 3
	EVADC_G4CH5			Analog input channel 5, group 4
T4	AN30	I	D / HighZ / VDDM	Analog Input 30
	EVADC_G3CH6			Analog input channel 6, group 3
	EVADC_G4CH6			Analog input channel 6, group 4
R4	AN31	I	D / HighZ / VDDM	Analog Input 31
	EVADC_G3CH7			Analog input channel 7, group 3
	EVADC_G4CH7			Analog input channel 7, group 4
P4	AN32/P40.4	I	S / HighZ / VDDM	Analog Input 32
	SENT_SENT4A			Receive input channel 4
	EVADC_G8CH0			Analog input channel 0, group 8
	CCU60_CCPOS2D			Hall capture input 2
	EVADC_G11CH12			Analog input channel 12, group 11
R1	AN33/P40.5	I	S / HighZ / VDDM	Analog Input 33
	SENT_SENT5A			Receive input channel 5
	EVADC_G8CH1			Analog input channel 1, group 8
	CCU61_CCPOS0D			Hall capture input 0
	EVADC_G11CH13			Analog input channel 13, group 11
P5	AN34	I	D / HighZ / VDDM	Analog Input 34
	EVADC_G8CH2			Analog input channel 2, group 8
	EVADC_G11CH14			Analog input channel 14, group 11
R2	AN35	I	D / HighZ / VDDM	Analog Input 35
	EVADC_G8CH3			Analog input channel 3, group 8
	EVADC_G11CH15			Analog input channel 15, group 11
N4	AN36/P40.6	I	S / HighZ / VDDM	Analog Input 36
	SENT_SENT6A			Receive input channel 6
	EVADC_G8CH4			Analog input channel 4, group 8
	CCU61_CCPOS1B			Hall capture input 1
	EDSADC_EDS1PA			Positive analog input channel 1, pin A

## Pin Definition and Functions BGA292 Package Variant Pin Configuration

Table 2-41 Analog Inputs (cont'd)

Ball	Symbol	Ctrl.	Buffer Type	Function
P2	AN37/P40.7	I	S / HighZ / VDDM	Analog Input 37
	SENT_SENT7A			Receive input channel 7
	EVADC_G8CH5			Analog input channel 5, group 8
	CCU61_CCPOS1D			Hall capture input 1
	EDSADC_EDS1NA			Negative analog input channel 1, pin A
N5	AN38/P40.8	I	S / HighZ / VDDM	Analog Input 38
	SENT_SENT8A			Receive input channel 8
	EVADC_G8CH6			Analog input channel 6, group 8
	CCU61_CCPOS2B			Hall capture input 2
	EDSADC_EDS1PB			Positive analog input channel 1, pin B
P1	AN39/P40.9	I	S / HighZ / VDDM	Analog Input 39
	SENT_SENT9A			Receive input channel 9
	EVADC_G8CH7			Analog input channel 7, group 8
	CCU61_CCPOS2D			Hall capture input 2
	EDSADC_EDS1NB			Negative analog input channel 1, pin B
M5	AN40	I	D / HighZ / VDDM	Analog Input 40
	EVADC_G8CH8			Analog input channel 8, group 8
	EVADC_G4CH0			Analog input channel 0, group 4
M4	AN41	I	D / HighZ / VDDM	Analog Input 41
	EVADC_G8CH9			Analog input channel 9, group 8
	EVADC_G4CH1			Analog input channel 1, group 4
L5	AN42	I	D / HighZ / VDDM	Analog Input 42
	EVADC_G8CH10			Analog input channel 10, group 8
	EVADC_G4CH2			Analog input channel 2, group 4
L4	AN43	I	D / HighZ / VDDM	Analog Input 43
	EVADC_G8CH11			Analog input channel 11, group 8
	EVADC_G4CH3			Analog input channel 3, group 4
N1	AN44	I	D / HighZ / VDDM	Analog Input 44
	EVADC_G8CH12			Analog input channel 12, group 8
	EDSADC_EDS1PC			Positive analog input channel 1, pin C
N2	AN45	I	D / HighZ / VDDM	Analog Input 45
	EVADC_G8CH13			Analog input channel 13, group 8
	EDSADC_EDS1NC			Negative analog input channel 1, pin C
M1	AN46	I	D / HighZ / VDDM	Analog Input 46
	EVADC_G8CH14			Analog input channel 14, group 8
	EDSADC_EDS1PD			Positive analog input channel 1, pin D

## Pin Definition and Functions BGA292 Package Variant Pin Configuration

Table 2-41 Analog Inputs (cont'd)

Ball	Symbol	Ctrl.	Buffer Type	Function
M2	AN47	I	D / HighZ / VDDM	<b>Analog Input 47</b>
	EVADC_G8CH15			<b>Analog input channel 15, group 8</b>
	EDSADC_EDS1ND			<b>Negative analog input channel 1, pin D</b>

Note: Port Pins P32.0 and P32.1 are bidirectional pads and are having the following two functionalities implemented:

- In case the pins are used as standard GPIOs the functions defined in the pin configuration tables of P32.0 and P32.1 are available.
- In case the pins are used as pre-drivers for external MOSFETs (internal DCDC usecase) P32.0 and P32.1 act as analog IOs named VGATE1N and VGATE1P.

Table 2-42 System I/O

Ball	Symbol	Ctrl.	Buffer Type	Function
G16	$\overline{\text{ESR1}}$	I/O	FAST / PU1 / VEXT	<b>ESR1 Port Pin input - can be used to trigger a reset or an NMI</b> ESR1: External System Request Reset 1. Default NMI function. See also SCU chapter for details. Default after power-on can be different. See also SCU chapter 'Reset Control Unit' and SCU_IOCRR register description. PMS_EVRWUP: EVR Wakeup Pin
	PMS_ESR1WKP	I		<b>ESR1 pin input</b>
F16	$\overline{\text{ESR0}}$	I/O	FAST / OD / VEXT	<b>ESR0 Port Pin input - can be used to trigger a reset or an NMI</b> ESR0: External System Request Reset 0. Default configuration during and after reset is open-drain driver. The driver drives low during power-on reset. This is valid additionally after deactivation of PORST_N until the internal reset phase has finished. See also SCU chapter for details. Default after power-on can be different. See also SCU chapter 'Reset Control Unit' and SCU_IOCRR register description. PMS_EVRWUP: EVR Wakeup Pin
	PMS_ESR0WKP	I		<b>ESR0 pin input</b>
W17	VGATE1P	O	—	<b>DCDC P ch. MOSFET gate driver output</b> P32.1 / External Pass Device gate control for EVRC
Y17	VGATE1N	O	—	<b>DCDC N ch. MOSFET gate driver output</b> P32.0 / SMPS mode: analog output. External Pass Device gate control for EVRC
M20	XTAL1	I	XTAL / VEXT	<b>XTAL pad1</b> XTAL1. Main Oscillator/PLL/Clock Generator Input.
M19	XTAL2	O	XTAL / VEXT	<b>XTAL pad2</b> XTAL2. Main Oscillator/PLL/Clock Generator OUTPUT

## Pin Definition and Functions BGA292 Package Variant Pin Configuration

Table 2-42 System I/O (cont'd)

Ball	Symbol	Ctrl.	Buffer Type	Function
L19	$\overline{\text{TRST}}$	I	FAST / PU2 / VEXT	<b>JTAG Module Reset/Enable Input</b>
J16	TCK	I	FAST /	<b>JTAG Module Clock Input</b>
	DAP0	I	PD2 / VEXT	<b>DAP: DAP0 Clock Input</b>
K16	TMS	I	FAST /	<b>JTAG Module State Machine Control Input</b>
	DAP1	I/O	PD2 / VEXT	<b>DAP: DAP1 Data I/O</b>
G17	$\overline{\text{PORST}}$	I/O	PORST / PD / VEXT	<b>PORST pin</b> Power On Reset Input. Additional strong PD in case of power fail.

Table 2-43 Supply

Ball	Symbol	Ctrl.	Buffer Type	Function
P8, P13, N7, N14, E15, H14, D16, G13, G8, H7	VDD	I	—	<b>Digital Core Power Supply (1.25V)</b>
A2, B3, V19, W20	VEXT	I	—	<b>External Power Supply (5V / 3.3V)</b>
D5	VFLEX	I	—	<b>Digital Power Supply for Flex Port Pads (5V / 3.3V)</b>
Y5	VDDM	I	—	<b>ADC Analog Power Supply (5V / 3.3V)</b>
B18, A19	VDDP3	I	—	<b>Flash Power Supply (3.3V)</b>
B2, D4, E5, T16, U17, W19, Y20, E16, D17, B19, A20	VSS	I	—	<b>Digital Ground</b>
Y4	VSSM	I	—	<b>Analog Ground for VDDM</b>

## Pin Definition and Functions BGA292 Package Variant Pin Configuration

Table 2-43 Supply (cont'd)

Ball	Symbol	Ctrl.	Buffer Type	Function
P9, P12, N9, N10, N11, N12, M7, M8, M10, M11, M13, M14, L8, L9, L10, L11, L12, L13, K8, K9, K10, K11, K12, K13, J7, J8, J10, J11, J13, J14, H9, H10, H11, H12, G9, G10, G11, G12, L14, P10, P11, K7, L7	VSS	I	—	Digital Ground
L20	VSS	I	—	Oscillator Ground, VSS(OSC)
Y6	VAREF1	I	—	Positive Analog Reference Voltage 1
Y7	VAGND1	I	—	Negative Analog Reference Voltage 1
T1	VAREF2	I	—	Positive Analog Reference Voltage 2
T2	VAGND2	I	—	Negative Analog Reference Voltage 2
K14	NC	I	—	Not connected. These pins are reserved for future extensions and shall not be connected externally
A1, Y1, U4	NC1	I	—	Not connected. These pins are not connected on package level and will not be used for future extensions
T11	VEVRSB	I	—	Standby Power Supply (5V / 3.3V) for the Standby SRAM
N19	VDD	I	—	Digital Power Supply for Oscillator (1.25V), VDD(OSC)
N20	VEXT	I	—	Digital Power Supply for Oscillator (shall be supplied with same level as used for VEXT), VEXT(OSC)

## 2.3 Sequence of Pads in Pad Frame

**Table 2-44 Pad List**

Number	Pad Name	Pad Type	X	Y	Comment
1	$\overline{\text{ESR1}}$	FAST / PU1 / VEXT	263799	179145	ESR1 Port Pin input - can be used to trigger a reset or an NMI ESR1: External System Request Reset 1. Default NMI function. See also SCU chapter for details. Default after power-on can be different. See also SCU chapter 'Reset Control Unit' and SCU_IOCRR register description. PMS_EVRWUP: EVR Wakeup Pin
2	$\overline{\text{ESR0}}$	FAST / OD / VEXT	357795	179145	ESR0 Port Pin input - can be used to trigger a reset or an NMI ESR0: External System Request Reset 0. Default configuration during and after reset is open-drain driver. The driver drives low during power-on reset. This is valid additionally after deactivation of PORST_N until the internal reset phase has finished. See also SCU chapter for details. Default after power-on can be different. See also SCU chapter 'Reset Control Unit' and SCU_IOCRR register description. PMS_EVRWUP: EVR Wakeup Pin
3	P20.9	FAST / PU1 / VEXT / ES	409293	348147	General-purpose I/O
4	P20.14	FAST / PU1 / VEXT / ES	456291	179145	General-purpose I/O
5	P15.0	FAST / PU1 / VEXT / ES	503289	348147	General-purpose I/O
6	P15.2	FAST / PU1 / VEXT / ES	550287	179145	General-purpose I/O
7	P15.4	FAST / PU1 / VEXT / ES	597285	348147	General-purpose I/O

**Pin Definition and Functions Sequence of Pads in Pad Frame**
**Table 2-44 Pad List (cont'd)**

Number	Pad Name	Pad Type	X	Y	Comment
8	P15.1	FAST / PU1 / VEXT / ES	644283	179145	General-purpose I/O
9	P15.3	FAST / PU1 / VEXT / ES	691281	348147	General-purpose I/O
10	P14.0	FAST / PU1 / VEXT / ES2	738279	179145	General-purpose I/O
11	VDDP3	Vx	785277	348147	Supply Voltage
12	P15.10	FAST / PU1 / VEXT / ES6	832275	179145	General-purpose I/O
13	P15.11	FAST / PU1 / VEXT / ES6	926271	179145	General-purpose I/O
14	VDD	Vx	973269	348147	Supply Voltage
15	VSS	Vx	1048869	179145	Supply Voltage
16	P15.12	FAST / PU1 / VEXT / ES6	1124469	348147	General-purpose I/O
17	P15.6	FAST / PU1 / VEXT / ES	1171467	179145	General-purpose I/O
18	P15.13	FAST / PU1 / VEXT / ES6	1218465	348147	General-purpose I/O
19	P15.7	FAST / PU1 / VEXT / ES	1265463	179145	General-purpose I/O
20	P15.14	FAST / PU1 / VEXT / ES	1312461	348147	General-purpose I/O
21	VEXT	Vx	1359459	179145	Supply Voltage
22	P15.15	FAST / PU1 / VEXT / ES	1406457	348147	General-purpose I/O
23	VSS	Vx	1453455	179145	Supply Voltage
24	P14.4	SLOW / PU2 / VEXT / ES	1500453	348147	General-purpose I/O
25	P15.8	FAST / PU1 / VEXT / ES	1547451	179145	General-purpose I/O
26	P14.1	FAST / PU1 / VEXT / ES2	1594449	348147	General-purpose I/O
27	P14.3	SLOW / PU2 / VEXT / ES	1641447	179145	General-purpose I/O
28	P14.5	FAST / PU2 / VEXT / ES	1688445	348147	General-purpose I/O
29	P15.5	FAST / PU1 / VEXT / ES	1735443	179145	General-purpose I/O
30	P14.11	SLOW / PU1 / VEXT / ES	1782441	348147	General-purpose I/O
31	VSS	Vx	1858041	179145	Supply Voltage

**Pin Definition and Functions Sequence of Pads in Pad Frame**
**Table 2-44 Pad List (cont'd)**

Number	Pad Name	Pad Type	X	Y	Comment
32	P14.12	SLOW / PU1 / VEXT / ES	1933641	348147	General-purpose I/O
33	VDD	Vx	2009241	179145	Supply Voltage
34	P14.13	FAST / PU1 / VEXT / ES	2084841	348147	General-purpose I/O
35	P14.7	SLOW / PU1 / VEXT / ES	2131839	179145	General-purpose I/O
36	P14.15	SLOW / PU1 / VEXT / ES	2178837	348147	General-purpose I/O
37	P14.6	FAST / PU1 / VEXT / ES	2225835	179145	General-purpose I/O
38	VEXT	Vx	2272833	348147	Supply Voltage
39	P14.9	LVDS_RX / FAST / PU1 / VEXT / ES	2347884	179145	General-purpose I/O
40	P14.10	LVDS_RX / FAST / PU1 / VEXT / ES	2441880	179145	General-purpose I/O
41	P14.8	SLOW / PU1 / VEXT / ES	2516931	348147	General-purpose I/O
42	P14.2	SLOW / PU2 / VEXT / ES	2563929	179145	General-purpose I/O
43	P13.0	LVDS_TX / FAST / PU1 / VEXT / ES6	2675430	348147	General-purpose I/O
44	P13.1	LVDS_TX / FAST / PU1 / VEXT / ES6	2769426	348147	General-purpose I/O
45	VDD	Vx	2880927	348147	Supply Voltage
46	VSS	Vx	2936925	179145	Supply Voltage
47	P13.2	LVDS_TX / FAST / PU1 / VEXT / ES6	3048426	348147	General-purpose I/O
48	P13.3	LVDS_TX / FAST / PU1 / VEXT / ES6	3142422	348147	General-purpose I/O
49	VDD	Vx	3253923	179145	Supply Voltage
50	P13.9	FAST / PU1 / VEXT / ES	3300921	348147	General-purpose I/O
51	VSS	Vx	3347919	179145	Supply Voltage
52	P13.4	LVDS_TX / FAST / PU1 / VEXT / ES6	3459420	348147	General-purpose I/O

**Pin Definition and Functions Sequence of Pads in Pad Frame**
**Table 2-44 Pad List (cont'd)**

Number	Pad Name	Pad Type	X	Y	Comment
53	P13.5	LVDS_TX / FAST / PU1 / VEXT / ES6	3553416	348147	General-purpose I/O
54	P13.6	LVDS_TX / FAST / PU1 / VEXT / ES6	3729420	348147	General-purpose I/O
55	P13.7	LVDS_TX / FAST / PU1 / VEXT / ES6	3823416	348147	General-purpose I/O
56	VDD	Vx	3934917	348147	Supply Voltage
57	VSS	Vx	3981915	179145	Supply Voltage
58	P13.10	SLOW / PU1 / VEXT / ES	4085973	348147	General-purpose I/O
59	VSS	Vx	4132971	179145	Supply Voltage
60	P13.12	SLOW / PU1 / VEXT / ES	4179969	348147	General-purpose I/O
61	VEXT	Vx	4226967	179145	Supply Voltage
62	VDDP3	Vx	4408965	348147	Supply Voltage
63	P13.13	SLOW / PU1 / VEXT / ES	4455963	179145	General-purpose I/O
64	VDDP3	Vx	4502961	348147	Supply Voltage
65	P13.14	SLOW / PU1 / VEXT / ES	4549959	179145	General-purpose I/O
66	VDDP3	Vx	4596957	348147	Supply Voltage
67	P13.11	SLOW / PU1 / VEXT / ES	4643955	179145	General-purpose I/O
68	P13.15	SLOW / PU1 / VEXT / ES	4690953	348147	General-purpose I/O
69	P14.14	FAST / PU1 / VEXT / ES	4737951	179145	General-purpose I/O
70	P12.0	SLOW / PU1 / VFLEX / ES	4832019	179145	General-purpose I/O
71	P12.1	SLOW / PU1 / VFLEX / ES	4879017	348147	General-purpose I/O
72	P11.0	RFAST / PU1 / VFLEX / ES	4983021	348147	General-purpose I/O
73	VFLEX	Vx	5030019	179145	Supply Voltage
74	P11.1	RFAST / PU1 / VFLEX / ES	5105223	348147	General-purpose I/O
75	VSS	Vx	5152221	179145	Supply Voltage
76	P11.2	RFAST / PU1 / VFLEX / ES	5227425	348147	General-purpose I/O

**Pin Definition and Functions Sequence of Pads in Pad Frame**
**Table 2-44 Pad List (cont'd)**

Number	Pad Name	Pad Type	X	Y	Comment
77	VDD	Vx	5274423	179145	Supply Voltage
78	P11.4	RFAST / PU1 / VFLEX / ES	5390127	348147	General-purpose I/O
79	VSS	Vx	5477625	179145	Supply Voltage
80	P11.3	RFAST / PU1 / VFLEX / ES	5552829	348147	General-purpose I/O
81	VFLEX	Vx	5599827	179145	Supply Voltage
82	P11.6	RFAST / PU1 / VFLEX / ES	5675031	348147	General-purpose I/O
83	VSS	Vx	5722029	179145	Supply Voltage
84	P11.5	SLOW / RGMII_Input / PU1 / VFLEX / ES	5769027	348147	General-purpose I/O
85	P11.7	SLOW / RGMII_Input / PU1 / VFLEX / ES	5821407	179145	General-purpose I/O
86	P11.9	FAST / RGMII_Input / PU1 / VFLEX / ES	5872005	348147	General-purpose I/O
87	VFLEX	Vx	5922603	179145	Supply Voltage
88	P11.8	SLOW / RGMII_Input / PU1 / VFLEX / ES	5969601	348147	General-purpose I/O
89	P11.10	FAST / RGMII_Input / PU1 / VFLEX / ES	6020199	179145	General-purpose I/O
90	P11.11	FAST / RGMII_Input / PU1 / VFLEX / ES	6070797	348147	General-purpose I/O
91	VSS	Vx	6121395	179145	Supply Voltage
92	P11.12	FAST / RGMII_Input / PU1 / VFLEX / ES	6168393	348147	General-purpose I/O
93	P11.14	SLOW / PU1 / VFLEX / ES	6276357	348147	General-purpose I/O
94	P11.13	SLOW / PU1 / VFLEX / ES	6323355	179145	General-purpose I/O

**Pin Definition and Functions Sequence of Pads in Pad Frame**
**Table 2-44 Pad List (cont'd)**

Number	Pad Name	Pad Type	X	Y	Comment
95	P11.15	SLOW / PU1 / VFLEX / ES	6370353	348147	General-purpose I/O
96	VDD	Vx	6444567	179145	Supply Voltage
97	VSS	Vx	6538563	179145	Supply Voltage
98	P10.0	SLOW / PU1 / VEXT / ES	6614163	348147	General-purpose I/O
99	VDD	Vx	6689763	179145	Supply Voltage
100	P10.3	FAST / PU1 / VEXT / ES	6765363	348147	General-purpose I/O
101	VSS	Vx	6840963	179145	Supply Voltage
102	P10.1	FAST / PU1 / VEXT / ES	6916563	348147	General-purpose I/O
103	VEXT	Vx	6972561	179145	Supply Voltage
104	P10.9	SLOW / PU1 / VEXT / ES	7089147	348147	General-purpose I/O
105	VSS	Vx	7176645	179145	Supply Voltage
106	P10.11	SLOW / PU1 / VEXT / ES	7306641	179145	General-purpose I/O
107	P10.4	FAST / PU1 / VEXT / ES	7391295	263799	General-purpose I/O
108	P10.10	SLOW / PU1 / VEXT / ES	7391295	357795	General-purpose I/O
109	P10.15	SLOW / PU1 / VEXT / ES	7222293	451791	General-purpose I/O
110	P10.13	SLOW / PU1 / VEXT / ES	7391295	545787	General-purpose I/O
111	P10.2	FAST / PU1 / VEXT / ES	7222293	639783	General-purpose I/O
112	P10.14	SLOW / PU1 / VEXT / ES	7391295	733779	General-purpose I/O
113	P10.6	SLOW / PU2 / VEXT / ES	7222293	795888	General-purpose I/O
114	P10.5	SLOW / PU2 / VEXT / ES	7391295	842886	General-purpose I/O
115	P10.8	SLOW / PU1 / VEXT / ES	7391295	936882	General-purpose I/O
116	P10.7	SLOW / PU1 / VEXT / ES	7222293	983880	General-purpose I/O
117	P02.0	FAST / PU1 / VEXT / ES	7391295	1030878	General-purpose I/O
118	P02.2	FAST / PU1 / VEXT / ES	7222293	1077876	General-purpose I/O

**Pin Definition and Functions Sequence of Pads in Pad Frame**
**Table 2-44 Pad List (cont'd)**

Number	Pad Name	Pad Type	X	Y	Comment
119	P02.1	SLOW / PU1 / VEXT / ES	7391295	1124874	General-purpose I/O
120	P02.5	FAST / PU1 / VEXT / ES	7222293	1171872	General-purpose I/O
121	P02.3	SLOW / PU1 / VEXT / ES	7391295	1218870	General-purpose I/O
122	P02.13	SLOW / PU1 / VEXT / ES	7222293	1265868	General-purpose I/O
123	P02.11	SLOW / PU1 / VEXT / ES	7391295	1312866	General-purpose I/O
124	P02.12	SLOW / PU1 / VEXT / ES	7222293	1359864	General-purpose I/O
125	P02.4	FAST / PU1 / VEXT / ES	7391295	1406862	General-purpose I/O
126	P02.15	FAST / PU1 / VEXT / ES	7222293	1453860	General-purpose I/O
127	VDD	Vx	7391295	1529460	Supply Voltage
128	VSS	Vx	7391295	1623456	Supply Voltage
129	P02.14	SLOW / PU1 / VEXT / ES	7222293	1699056	General-purpose I/O
130	P02.6	FAST / PU1 / VEXT / ES	7391295	1746054	General-purpose I/O
131	P01.0	SLOW / PU1 / VEXT / ES	7222293	1793052	General-purpose I/O
132	P02.7	FAST / PU1 / VEXT / ES	7391295	1840050	General-purpose I/O
133	P01.1	SLOW / PU1 / VEXT / ES	7222293	1887048	General-purpose I/O
134	P02.8	SLOW / PU1 / VEXT / ES	7391295	1934046	General-purpose I/O
135	P01.2	SLOW / PU1 / VEXT / ES	7222293	1981044	General-purpose I/O
136	P02.9	SLOW / PU1 / VEXT / ES	7391295	2028042	General-purpose I/O
137	P01.8	SLOW / PU1 / VEXT / ES	7222293	2075040	General-purpose I/O
138	VEXT	Vx	7391295	2122038	Supply Voltage
139	P01.9	SLOW / PU1 / VEXT / ES	7222293	2169036	General-purpose I/O
140	VSS	Vx	7391295	2216034	Supply Voltage
141	P01.11	SLOW / PU1 / VEXT / ES	7222293	2263032	General-purpose I/O

**Pin Definition and Functions Sequence of Pads in Pad Frame**
**Table 2-44 Pad List (cont'd)**

Number	Pad Name	Pad Type	X	Y	Comment
142	P02.10	SLOW / PU1 / VEXT / ES	7391295	2310030	General-purpose I/O
143	P01.10	SLOW / PU1 / VEXT / ES	7222293	2357028	General-purpose I/O
144	VSS	Vx	7391295	2432628	Supply Voltage
145	VDD	Vx	7391295	2526624	Supply Voltage
146	P00.0	FAST / PU1 / VEXT / ES	7391295	2620620	General-purpose I/O
147	P01.13	FAST / PU1 / VEXT / ES	7222293	2667618	General-purpose I/O
148	P01.4	SLOW / PU1 / VEXT / ES	7391295	2714616	General-purpose I/O
149	P01.12	FAST / PU1 / VEXT / ES	7222293	2761614	General-purpose I/O
150	P01.3	SLOW / PU1 / VEXT / ES	7391295	2808612	General-purpose I/O
151	P01.15	SLOW / PU1 / VEXT / ES	7222293	2855610	General-purpose I/O
152	P01.6	FAST / PU1 / VEXT / ES	7391295	2902608	General-purpose I/O
153	P01.14	FAST / PU1 / VEXT / ES	7222293	2949606	General-purpose I/O
154	P01.5	SLOW / PU1 / VEXT / ES	7391295	2996604	General-purpose I/O
155	P00.15	FAST / PU1 / VEXT / ES	7222293	3043602	General-purpose I/O
156	P01.7	FAST / PU1 / VEXT / ES	7391295	3090600	General-purpose I/O
157	P00.13	FAST / PU1 / VEXT / ES	7222293	3137598	General-purpose I/O
158	RESERVED	Vx	7391295	3184596	PBIST_OFFMust be bonded to VSS
159	RESERVED	Vx	7391295	3278592	OTPMust be bonded to VSS
160	P00.14	SLOW / PU1 / VEXT / ES	7222293	3325590	General-purpose I/O
161	VSS	Vx	7391295	3401190	Supply Voltage
162	VDD	Vx	7391295	3495186	Supply Voltage
164	P00.1	SLOW / PU1 / VEXT / ES	7222293	3572226	General-purpose I/O
165	P00.2	SLOW / PU1 / VEXT / ES1	7391295	3619224	General-purpose I/O

**Pin Definition and Functions Sequence of Pads in Pad Frame**
**Table 2-44 Pad List (cont'd)**

Number	Pad Name	Pad Type	X	Y	Comment
166	P00.3	SLOW / PU1 / VEXT / ES1	7222293	3666222	General-purpose I/O
167	P00.4	SLOW / PU1 / VEXT / ES1	7391295	3713220	General-purpose I/O
168	P00.5	SLOW / PU1 / VEXT / ES1	7222293	3760218	General-purpose I/O
169	VSS	Vx	7391295	3807216	Supply Voltage
170	P00.6	SLOW / PU1 / VEXT / ES1	7222293	3854214	General-purpose I/O
171	VEXT	Vx	7391295	3901212	Supply Voltage
172	P00.7	SLOW / PU1 / VEXT / ES1	7222293	3948210	General-purpose I/O
173	P00.8	SLOW / PU1 / VEXT / ES1	7391295	3995208	General-purpose I/O
174	P00.9	SLOW / PU1 / VEXT / ES1	7222293	4042206	General-purpose I/O
175	P00.10	SLOW / PU1 / VEXT / ES1	7391295	4089204	General-purpose I/O
176	P00.11	SLOW / PU1 / VEXT / ES1	7222293	4136202	General-purpose I/O
177	P00.12	SLOW / PU1 / VEXT / ES1	7391295	4183200	General-purpose I/O
179	AN47	D / HighZ / VDDM	7222293	4257414	Analog Input 47
180	AN46	D / HighZ / VDDM	7391295	4304412	Analog Input 46
181	AN45	D / HighZ / VDDM	7222293	4351410	Analog Input 45
182	AN44	D / HighZ / VDDM	7391295	4398408	Analog Input 44
183	VDDM	Vx	7222293	4445406	Supply Voltage
184	VSSM	Vx	7391295	4492404	Supply Voltage
185	VAREF5	Vx	7222293	4539402	Supply Voltage
186	VAREF4	Vx	7391295	4586400	Supply Voltage
187	VAGND5	Vx	7222293	4633398	Supply Voltage
188	VAGND4	Vx	7391295	4680396	Supply Voltage
189	AN43	D / HighZ / VDDM	7222293	4727394	Analog Input 43
190	AN42	D / HighZ / VDDM	7391295	4774392	Analog Input 42
191	AN41	D / HighZ / VDDM	7222293	4821390	Analog Input 41

**Pin Definition and Functions Sequence of Pads in Pad Frame**
**Table 2-44 Pad List (cont'd)**

Number	Pad Name	Pad Type	X	Y	Comment
192	VSSM	Vx	7391295	4868388	Supply Voltage
193	VDDM	Vx	7222293	4915386	Supply Voltage
194	AN40	D / HighZ / VDDM	7391295	4962384	Analog Input 40
195	AN39/P40.9	S / HighZ / VDDM	7222293	5009382	Analog Input 39
196	VSSM	Vx	7391295	5056380	Supply Voltage
197	AN38/P40.8	S / HighZ / VDDM	7222293	5103378	Analog Input 38
198	VDDM	Vx	7391295	5150376	Supply Voltage
199	AN37/P40.7	S / HighZ / VDDM	7222293	5197374	Analog Input 37
200	AN36/P40.6	S / HighZ / VDDM	7391295	5244372	Analog Input 36
201	AN35	D / HighZ / VDDM	7222293	5291370	Analog Input 35
202	AN34	D / HighZ / VDDM	7391295	5338368	Analog Input 34
203	AN33/P40.5	S / HighZ / VDDM	7222293	5385366	Analog Input 33
204	AN32/P40.4	S / HighZ / VDDM	7391295	5432364	Analog Input 32
205	VAREF3	Vx	7222293	5479362	Supply Voltage
206	VAREF2	Vx	7391295	5526360	Supply Voltage
207	VAGND3	Vx	7222293	5573358	Supply Voltage
208	VAGND2	Vx	7391295	5620356	Supply Voltage
209	AN71/P41.3	S / HighZ / VDDM	7222293	5667354	Analog Input 71
210	AN70/P41.2	S / HighZ / VDDM	7391295	5714352	Analog Input 70
211	AN69/P41.1	S / HighZ / VDDM	7222293	5761350	Analog Input 69
212	AN68/P41.0	S / HighZ / VDDM	7391295	5808348	Analog Input 68
213	AN67/P40.15	S / HighZ / VDDM	7222293	5855346	Analog Input 67
214	AN66	D / HighZ / VDDM	7391295	5902344	Analog Input 66
215	AN65	D / HighZ / VDDM	7222293	5949342	Analog Input 65
216	AN64/P41.8	S / HighZ / VDDM	7391295	5996340	Analog Input 64

**Pin Definition and Functions Sequence of Pads in Pad Frame**
**Table 2-44 Pad List (cont'd)**

Number	Pad Name	Pad Type	X	Y	Comment
217	VDDM	Vx	7222293	6043338	Supply Voltage
218	VSSM	Vx	7391295	6090336	Supply Voltage
219	AN63/P41.7	S / HighZ / VDDM	7222293	6137334	Analog Input 63
220	AN62/P41.6	S / HighZ / VDDM	7391295	6184332	Analog Input 62
221	AN61	D / HighZ / VDDM	7222293	6231330	Analog Input 61
222	AN60	D / HighZ / VDDM	7391295	6278328	Analog Input 60
223	AN59	D / HighZ / VDDM	7222293	6325326	Analog Input 59
224	AN58	D / HighZ / VDDM	7391295	6372324	Analog Input 58
225	AN57	D / HighZ / VDDM	7222293	6419322	Analog Input 57
226	AN56	D / HighZ / VDDM	7391295	6466320	Analog Input 56
227	AN55/P41.5	S / HighZ / VDDM	7222293	6513318	Analog Input 55
228	AN54/P41.4	S / HighZ / VDDM	7391295	6560316	Analog Input 54
229	AN53	D / HighZ / VDDM	7222293	6607314	Analog Input 53
230	AN52	D / HighZ / VDDM	7391295	6654312	Analog Input 52
231	AN51	D / HighZ / VDDM	7222293	6701310	Analog Input 51
232	AN50	D / HighZ / VDDM	7391295	6748308	Analog Input 50
233	AN49	D / HighZ / VDDM	7222293	6795306	Analog Input 49
234	AN48	D / HighZ / VDDM	7391295	6842304	Analog Input 48
235	AN31	D / HighZ / VDDM	7391295	6936300	Analog Input 31
236	AN30	D / HighZ / VDDM	7302141	7058295	Analog Input 30
237	AN29/P40.14	S / HighZ / VDDM	7208145	7058295	Analog Input 29
238	AN28/P40.13	S / HighZ / VDDM	7161147	6889293	Analog Input 28

**Pin Definition and Functions Sequence of Pads in Pad Frame**
**Table 2-44 Pad List (cont'd)**

Number	Pad Name	Pad Type	X	Y	Comment
239	AN27/P40.3	S / HighZ / VDDM	7114149	7058295	Analog Input 27
240	AN26/P40.2	S / HighZ / VDDM	7067151	6889293	Analog Input 26
241	AN25/P40.1	S / HighZ / VDDM	7020153	7058295	Analog Input 25
242	AN24/P40.0	S / HighZ / VDDM	6973155	6889293	Analog Input 24
243	AN23	D / HighZ / VDDM	6926157	7058295	Analog Input 23
244	AN22	D / HighZ / VDDM	6879159	6889293	Analog Input 22
245	AN21	D / HighZ / VDDM	6832161	7058295	Analog Input 21
246	AN20	D / HighZ / VDDM	6785163	6889293	Analog Input 20
247	AN19/P40.12	S / HighZ / VDDM	6738165	7058295	Analog Input 19
248	AN18/P40.11	S / HighZ / VDDM	6691167	6889293	Analog Input 18
249	AN17/P40.10	S / HighZ / VDDM	6644169	7058295	Analog Input 17
250	AN16	D / HighZ / VDDM	6597171	6889293	Analog Input 16
251	AN15	D / HighZ / VDDM	6550173	7058295	Analog Input 15
252	VAGND1	Vx	6503175	6889293	Supply Voltage
253	VAGND0	Vx	6456177	7058295	Supply Voltage
254	VAREF1	Vx	6409179	6889293	Supply Voltage
255	VAREF0	Vx	6362181	7058295	Supply Voltage
256	AN14	D / HighZ / VDDM	6315183	6889293	Analog Input 14
257	AN13	D / HighZ / VDDM	6268185	7058295	Analog Input 13
258	VDDM	Vx	6221187	6889293	Supply Voltage
259	VSSM	Vx	6174189	7058295	Supply Voltage
260	AN12	D / HighZ / VDDM	6127191	6889293	Analog Input 12
261	VSSM	Vx	6080193	7058295	Supply Voltage
262	VDDM	Vx	6033195	6889293	Supply Voltage
263	AN11	D / HighZ / VDDM	5986197	7058295	Analog Input 11

**Pin Definition and Functions Sequence of Pads in Pad Frame**
**Table 2-44 Pad List (cont'd)**

Number	Pad Name	Pad Type	X	Y	Comment
264	AN10	D / HighZ / VDDM	5939199	6889293	Analog Input 10
265	AN9	D / HighZ / VDDM	5892201	7058295	Analog Input 9
266	AN8	D / HighZ / VDDM	5845203	6889293	Analog Input 8
267	AN7	D / HighZ / VDDM	5798205	7058295	Analog Input 7
268	AN6	D / HighZ / VDDM	5751207	6889293	Analog Input 6
269	AN5	D / HighZ / VDDM	5704209	7058295	Analog Input 5
270	AN4	D / HighZ / VDDM	5657211	6889293	Analog Input 4
271	AN3	D / HighZ / VDDM	5610213	7058295	Analog Input 3
272	AN2	D / HighZ / VDDM	5563215	6889293	Analog Input 2
273	AN1	D / HighZ / VDDM	5516217	7058295	Analog Input 1
274	AN0	D / HighZ / VDDM	5469219	6889293	Analog Input 0
276	VSS	Vx	5386005	7058295	Supply Voltage
277	VDD	Vx	5310405	6889293	Supply Voltage
278	VDD	Vx	5234805	7058295	Supply Voltage
279	VSS	Vx	5140809	7058295	Supply Voltage
280	VEXT	Vx	4961709	6889293	Supply Voltage
281	P32.1	SLOW / PU1 / VEXT / ES	4914711	7058295	General-purpose I/O
282	VGATE1P	Vx	4867713	6889293	DCDC P ch. MOSFET gate driver output
283	VSS	Vx	4802715	7058295	Supply Voltage
284	VGATE1N	Vx	4737717	6889293	DCDC N ch. MOSFET gate driver output
285	P32.0	SLOW / PU1 / VEXT / ES	4690719	7058295	General-purpose I/O
286	VEVRSB	Vx	4607505	6889293	Supply Voltage
287	VEVRSB	Vx	4560507	7058295	Supply Voltage
288	P33.1	SLOW / PU1 / VEVRSB / ES5	4513509	6889293	General-purpose I/O
289	VSS	Vx	4466511	7058295	Supply Voltage

**Pin Definition and Functions Sequence of Pads in Pad Frame**
**Table 2-44 Pad List (cont'd)**

Number	Pad Name	Pad Type	X	Y	Comment
290	VSS	—	4354515	7058295	Supply Voltage
291	VDD	—	4307517	6889293	Supply Voltage
292	P33.0	SLOW / PU1 / VEVRSB / ES5	4260519	7058295	General-purpose I/O
293	P33.3	SLOW / PU1 / VEVRSB / ES5	4213521	6889293	General-purpose I/O
294	P33.2	SLOW / PU1 / VEVRSB / ES5	4166523	7058295	General-purpose I/O
295	P33.5	SLOW / PU1 / VEVRSB / ES5	4119525	6889293	General-purpose I/O
296	VSS	Vx	4016925	7058295	Supply Voltage
297	VDD	Vx	3969927	6889293	Supply Voltage
298	P34.1	SLOW / PU1 / VEVRSB / ES5	3922929	7058295	General-purpose I/O
299	P33.4	SLOW / PU1 / VEVRSB / ES5	3875931	6889293	General-purpose I/O
300	P34.3	SLOW / PU1 / VEVRSB / ES	3828933	7058295	General-purpose I/O
301	P33.7	SLOW / PU1 / VEVRSB / ES5	3781935	6889293	General-purpose I/O
302	P34.2	SLOW / PU1 / VEVRSB / ES	3734937	7058295	General-purpose I/O
303	P33.6	SLOW / PU1 / VEVRSB / ES5	3687939	6889293	General-purpose I/O
304	P34.5	FAST / PU1 / VEVRSB / ES	3640941	7058295	General-purpose I/O
305	P33.9	SLOW / PU1 / VEVRSB / ES5	3593943	6889293	General-purpose I/O
306	VEVRSB	Vx	3546945	7058295	Supply Voltage
307	P33.8	FAST / HighZ / VEVRSB	3499947	6889293	General-purpose I/O
308	P34.4	SLOW / PU1 / VEVRSB / ES	3452949	7058295	General-purpose I/O

**Pin Definition and Functions Sequence of Pads in Pad Frame**
**Table 2-44 Pad List (cont'd)**

Number	Pad Name	Pad Type	X	Y	Comment
309	P33.11	FAST / PU1 / VEVRSB / ES5	3405951	6889293	General-purpose I/O
310	VSS	Vx	3303153	7058295	Supply Voltage
311	VDD	Vx	3256155	6889293	Supply Voltage
312	VSS	Vx	3209157	7058295	Supply Voltage
313	P33.10	FAST / PU1 / VEVRSB / ES5	3162159	6889293	General-purpose I/O
314	P33.15	SLOW / PU1 / VEVRSB / ES5	3115161	7058295	General-purpose I/O
315	P33.13	FAST / PU1 / VEVRSB / ES5	3068163	6889293	General-purpose I/O
316	P33.14	FAST / PU1 / VEVRSB / ES5	3021165	7058295	General-purpose I/O
317	P33.12	FAST / PU1 / VEVRSB / ES5	2974167	6889293	General-purpose I/O
318	VDD	—	2890953	7058295	Supply Voltage
319	VSS	—	2796957	7058295	Supply Voltage
320	P32.2	SLOW / PU1 / VEXT / ES	2721357	6889293	General-purpose I/O
321	P32.5	SLOW / PU1 / VEXT / ES	2674359	7058295	General-purpose I/O
322	P32.4	FAST / PU1 / VEXT / ES	2627361	6889293	General-purpose I/O
323	VSS	Vx	2580363	7058295	Supply Voltage
324	VEXT	Vx	2533365	6889293	Supply Voltage
325	P32.3	SLOW / PU1 / VEXT / ES	2486367	7058295	General-purpose I/O
326	P32.7	SLOW / PU1 / VEXT / ES	2439369	6889293	General-purpose I/O
327	VSS	Vx	2363769	7058295	Supply Voltage
328	P32.6	SLOW / PU1 / VEXT / ES	2288169	6889293	General-purpose I/O
329	VDD	Vx	2212569	7058295	Supply Voltage
330	P31.1	FAST / PU1 / VEXT / ES	2136969	6889293	General-purpose I/O
331	P31.0	FAST / PU1 / VEXT / ES	2089971	7058295	General-purpose I/O

**Pin Definition and Functions Sequence of Pads in Pad Frame**
**Table 2-44 Pad List (cont'd)**

Number	Pad Name	Pad Type	X	Y	Comment
332	P31.3	FAST / PU1 / VEXT / ES	2042973	6889293	General-purpose I/O
333	P31.2	FAST / PU1 / VEXT / ES	1995975	7058295	General-purpose I/O
334	P31.4	FAST / PU1 / VEXT / ES	1948977	6889293	General-purpose I/O
335	P31.5	FAST / PU1 / VEXT / ES	1901979	7058295	General-purpose I/O
336	P31.6	FAST / PU1 / VEXT / ES	1854981	6889293	General-purpose I/O
337	P31.7	FAST / PU1 / VEXT / ES	1807983	7058295	General-purpose I/O
338	P31.8	FAST / PU1 / VEXT / ES	1760985	6889293	General-purpose I/O
339	P31.10	FAST / PU1 / VEXT / ES	1713987	7058295	General-purpose I/O
340	P31.9	FAST / PU1 / VEXT / ES	1666989	6889293	General-purpose I/O
341	P31.12	FAST / PU1 / VEXT / ES	1619991	7058295	General-purpose I/O
342	P31.11	FAST / PU1 / VEXT / ES	1572993	6889293	General-purpose I/O
343	P31.14	FAST / PU1 / VEXT / ES	1525995	7058295	General-purpose I/O
344	P31.13	FAST / PU1 / VEXT / ES	1478997	6889293	General-purpose I/O
345	VDD	Vx	1403397	7058295	Supply Voltage
346	VSS	Vx	1309401	7058295	Supply Voltage
347	P31.15	FAST / PU1 / VEXT / ES	1233801	6889293	General-purpose I/O
348	P30.2	FAST / PU1 / VEXT / ES	1186803	7058295	General-purpose I/O
349	P30.0	FAST / PU1 / VEXT / ES	1139805	6889293	General-purpose I/O
350	VSS	Vx	1092807	7058295	Supply Voltage
351	P30.1	FAST / PU1 / VEXT / ES	1045809	6889293	General-purpose I/O
352	VEXT	Vx	998811	7058295	Supply Voltage
353	P30.3	FAST / PU1 / VEXT / ES	951813	6889293	General-purpose I/O
354	P30.5	FAST / PU1 / VEXT / ES	904815	7058295	General-purpose I/O

**Pin Definition and Functions Sequence of Pads in Pad Frame**
**Table 2-44 Pad List (cont'd)**

Number	Pad Name	Pad Type	X	Y	Comment
355	P30.4	FAST / PU1 / VEXT / ES	857817	6889293	General-purpose I/O
356	P30.8	FAST / PU1 / VEXT / ES	810819	7058295	General-purpose I/O
357	VDD	Vx	763821	6889293	Supply Voltage
358	VSS	Vx	716823	7058295	Supply Voltage
359	VDD	Vx	614223	6889293	Supply Voltage
360	VSS	Vx	538623	7058295	Supply Voltage
361	P30.6	FAST / PU1 / VEXT / ES	463023	6889293	General-purpose I/O
362	P30.9	FAST / PU1 / VEXT / ES	357795	7058295	General-purpose I/O
363	P30.7	FAST / PU1 / VEXT / ES	263799	7058295	General-purpose I/O
369	P30.10	FAST / PU1 / VEXT / ES	179145	6973641	General-purpose I/O
370	P30.11	FAST / PU1 / VEXT / ES	179145	6879645	General-purpose I/O
371	P30.14	FAST / PU1 / VEXT / ES	348147	6828147	General-purpose I/O
372	P30.15	FAST / PU1 / VEXT / ES	179145	6781149	General-purpose I/O
373	P30.13	FAST / PU1 / VEXT / ES	348147	6734151	General-purpose I/O
374	P30.12	FAST / PU1 / VEXT / ES	179145	6687153	General-purpose I/O
375	P26.0	SLOW / PU1 / VEXT / ES	348147	6640155	General-purpose I/O
376	P25.0	FAST / PU1 / VEXT / ES	179145	6593157	General-purpose I/O
377	P23.0	SLOW / PU1 / VEXT / ES	348147	6546159	General-purpose I/O
378	P23.1	FAST / PU1 / VEXT / ES	179145	6499161	General-purpose I/O
379	P23.2	SLOW / PU1 / VEXT / ES	348147	6443163	General-purpose I/O
380	P25.2	FAST / PU1 / VEXT / ES	179145	6396165	General-purpose I/O
381	P23.3	SLOW / PU1 / VEXT / ES	348147	6349167	General-purpose I/O
382	P25.1	FAST / PU1 / VEXT / ES	179145	6302169	General-purpose I/O

**Pin Definition and Functions Sequence of Pads in Pad Frame**
**Table 2-44 Pad List (cont'd)**

Number	Pad Name	Pad Type	X	Y	Comment
383	VEXT	Vx	348147	6255171	Supply Voltage
384	P25.4	FAST / PU1 / VEXT / ES	179145	6208173	General-purpose I/O
385	VSS	Vx	348147	6161175	Supply Voltage
386	P23.5	FAST / PU1 / VEXT / ES	179145	6114177	General-purpose I/O
387	P23.6	SLOW / PU1 / VEXT / ES	348147	6067179	General-purpose I/O
388	P23.7	SLOW / PU1 / VEXT / ES	179145	6020181	General-purpose I/O
389	P25.3	FAST / PU1 / VEXT / ES	348147	5973183	General-purpose I/O
390	P22.4	SLOW / PU1 / VEXT / ES	179145	5926185	General-purpose I/O
391	P25.7	FAST / PU1 / VEXT / ES	348147	5879187	General-purpose I/O
392	P25.5	FAST / PU1 / VEXT / ES	179145	5832189	General-purpose I/O
393	P25.8	FAST / PU1 / VEXT / ES	348147	5785191	General-purpose I/O
394	P25.9	FAST / PU1 / VEXT / ES	179145	5738193	General-purpose I/O
395	P25.10	FAST / PU1 / VEXT / ES	348147	5691195	General-purpose I/O
396	P22.5	SLOW / PU1 / VEXT / ES	179145	5644197	General-purpose I/O
397	P25.11	FAST / PU1 / VEXT / ES	348147	5588199	General-purpose I/O
398	VSS	Vx	179145	5512599	Supply Voltage
399	VDD	Vx	348147	5436999	Supply Voltage
400	P25.12	FAST / PU1 / VEXT / ES	179145	5390001	General-purpose I/O
401	P23.4	FAST / PU1 / VEXT / ES	348147	5343003	General-purpose I/O
402	P25.14	FAST / PU1 / VEXT / ES	179145	5296005	General-purpose I/O
403	P25.13	FAST / PU1 / VEXT / ES	348147	5249007	General-purpose I/O
404	P25.15	FAST / PU1 / VEXT / ES	179145	5202009	General-purpose I/O
405	P25.6	FAST / PU1 / VEXT / ES	348147	5155011	General-purpose I/O

**Pin Definition and Functions Sequence of Pads in Pad Frame**
**Table 2-44 Pad List (cont'd)**

Number	Pad Name	Pad Type	X	Y	Comment
406	P24.1	FAST / PU1 / VEXT / ES	179145	5108013	General-purpose I/O
407	P24.0	FAST / PU1 / VEXT / ES	348147	5061015	General-purpose I/O
408	P24.3	FAST / PU1 / VEXT / ES	179145	5014017	General-purpose I/O
409	P24.2	FAST / PU1 / VEXT / ES	348147	4967019	General-purpose I/O
410	P24.5	FAST / PU1 / VEXT / ES	179145	4920021	General-purpose I/O
411	P24.4	FAST / PU1 / VEXT / ES	348147	4873023	General-purpose I/O
412	VEXT	Vx	179145	4826025	Supply Voltage
413	VSS	Vx	348147	4779027	Supply Voltage
414	P22.7	SLOW / PU1 / VEXT / ES	179145	4732029	General-purpose I/O
415	P24.9	FAST / PU1 / VEXT / ES	348147	4685031	General-purpose I/O
416	P22.6	SLOW / PU1 / VEXT / ES	179145	4638033	General-purpose I/O
417	P24.8	FAST / PU1 / VEXT / ES	348147	4591035	General-purpose I/O
418	P22.8	SLOW / PU1 / VEXT / ES	179145	4544037	General-purpose I/O
419	P22.2	LVDS_TX / FAST / PU1 / VEXT / ES6	348147	4432536	General-purpose I/O
420	P22.3	LVDS_TX / FAST / PU1 / VEXT / ES6	348147	4338540	General-purpose I/O
421	VDD	Vx	179145	4227039	Supply Voltage
422	P22.0	LVDS_TX / FAST / PU1 / VEXT / ES6	348147	4115538	General-purpose I/O
423	P22.1	LVDS_TX / FAST / PU1 / VEXT / ES6	348147	4021542	General-purpose I/O
424	VSS	Vx	179145	3910041	Supply Voltage
425	P24.6	FAST / PU1 / VEXT / ES	348147	3834441	General-purpose I/O
426	P24.7	FAST / PU1 / VEXT / ES	179145	3787443	General-purpose I/O

**Pin Definition and Functions Sequence of Pads in Pad Frame**
**Table 2-44 Pad List (cont'd)**

Number	Pad Name	Pad Type	X	Y	Comment
427	P24.11	FAST / PU1 / VEXT / ES	348147	3740445	General-purpose I/O
428	VSS	Vx	179145	3664845	Supply Voltage
429	VDD	Vx	348147	3570849	Supply Voltage
430	P24.10	FAST / PU1 / VEXT / ES	179145	3495249	General-purpose I/O
432	VDD	Vx	348147	3406041	Supply Voltage
433	VSS	Vx	179145	3359043	Supply Voltage
434	XTAL1	XTAL / VEXT	179145	3199392	XTAL pad1 XTAL1. Main Oscillator/PLL/Clock Generator Input.
435	XTAL2	XTAL / VEXT	179145	3105396	XTAL pad2 XTAL2. Main Oscillator/PLL/Clock Generator OUTPUT
436	VSS	—	179145	2945745	Supply Voltage
437	VEXT	Vx	348147	2898747	Supply Voltage
439	P24.13	FAST / PU1 / VEXT / ES	348147	2764233	General-purpose I/O
440	P22.11	SLOW / PU1 / VEXT / ES	179145	2717235	General-purpose I/O
441	P24.12	FAST / PU1 / VEXT / ES	348147	2670237	General-purpose I/O
442	P22.10	SLOW / PU1 / VEXT / ES	179145	2623239	General-purpose I/O
443	P24.15	FAST / PU1 / VEXT / ES	348147	2576241	General-purpose I/O
444	P22.9	SLOW / PU1 / VEXT / ES	179145	2529243	General-purpose I/O
445	P24.14	FAST / PU1 / VEXT / ES	348147	2482245	General-purpose I/O
446	$\overline{\text{TRST}}$	FAST / PU2 / VEXT	179145	2435247	JTAG Module Reset/Enable Input
447	P21.0	LVDS_RX / FAST / PU1 / VEXT / ES	348147	2360196	General-purpose I/O
448	P21.1	LVDS_RX / FAST / PU1 / VEXT / ES	348147	2266200	General-purpose I/O
449	VDD	Vx	179145	2191149	Supply Voltage

**Pin Definition and Functions Sequence of Pads in Pad Frame**
**Table 2-44 Pad List (cont'd)**

Number	Pad Name	Pad Type	X	Y	Comment
450	P21.2	LVDS_RX / FAST / PU1 / VEXT / ES	348147	2116098	General-purpose I/O
451	P21.3	LVDS_RX / FAST / PU1 / VEXT / ES	348147	2022102	General-purpose I/O
452	VSS	Vx	179145	1947051	Supply Voltage
453	P21.4	LVDS_TX / FAST / PU1 / VEXT / ES6	348147	1835550	General-purpose I/O
454	P21.5	LVDS_TX / FAST / PU1 / VEXT / ES6	348147	1741554	General-purpose I/O
455	VDD	Vx	348147	1630053	Supply Voltage
456	VSS	Vx	179145	1554453	Supply Voltage
457	VSS	Vx	348147	1460457	Supply Voltage
458	VEXT	Vx	179145	1413459	Supply Voltage
459	P20.0	FAST / PU1 / VEXT / ES	348147	1366461	General-purpose I/O
460	TCK	FAST / PD2 / VEXT	179145	1319463	JTAG Module Clock Input
461	P20.2	S / PU / VEXT	348147	1272465	General-purpose I/O This pin is latched at power on reset release to enter test mode.
462	TMS	FAST / PD2 / VEXT	179145	1225467	JTAG Module State Machine Control Input
463	P20.3	SLOW / PU1 / VEXT / ES	348147	1178469	General-purpose I/O
464	P21.7/TDO	FAST / PU2 / VEXT / ES4	179145	1131471	General-purpose I/O
465	P20.1	SLOW / PU1 / VEXT / ES	348147	1084473	General-purpose I/O
466	VEXT	Vx	179145	1037475	Supply Voltage
467	P20.8	FAST / PU1 / VEXT / ES	348147	990477	General-purpose I/O
468	VSS	Vx	179145	943479	Supply Voltage
469	P20.7	FAST / PU1 / VEXT / ES	348147	896481	General-purpose I/O
470	VDD	Vx	179145	820881	Supply Voltage
471	P20.11	FAST / PU1 / VEXT / ES	348147	745281	General-purpose I/O

**Pin Definition and Functions Sequence of Pads in Pad Frame**
**Table 2-44 Pad List (cont'd)**

Number	Pad Name	Pad Type	X	Y	Comment
472	P21.6/TDI	FAST / PD / PU2 / VEXT / ES3	179145	698283	General-purpose I/O PD during Reset and in DAP/DAPE or JTAG mode. After Reset release and when not in DAP/DAPE or JTAG mode: PU. In Standby mode: HighZ.
473	P20.10	FAST / PU1 / VEXT / ES	348147	651285	General-purpose I/O
474	VSS	Vx	179145	575685	Supply Voltage
475	P20.13	FAST / PU1 / VEXT / ES	348147	500085	General-purpose I/O
476	$\overline{\text{PORST}}$	PORST / PD / VEXT	179145	451791	PORST pin Power On Reset Input. Additional strong PD in case of power fail.
477	P20.12	FAST / PU1 / VEXT / ES	179145	357795	General-purpose I/O
478	P20.6	SLOW / PU1 / VEXT / ES	179145	263799	General-purpose I/O

Whenever in table of section 3 'Electrical Specification' the term 'neighbor pads' is used, the detailed definition is provided by [Figure 2-44](#). This statement is also valid for next/nearest neighbor pads.

In order to find out who is affecting operation on a target pad (interfering) a number of active close-neighbor pads (ACNP) has to be defined.

Finding close-neighbor pads.

The Pad Ring has four edges: bottom, left, top, right. Each edge is limited, i.e. it has two ends.

Each pad has two direct (first) neighbors unless it is located at the end of the edge. In that case it only has one neighbor. Similarly, each pad has two indirect (second) neighbors unless it or its first neighbor is located at the end of the edge. These first and second neighbors we will collectively call Close-Neighbor pads. Therefore each pad has 2 to 4 close-neighbor pads.

Finding close-neighbors can be done with the following sequence:

- 1.) Choose a target pad and lookup its "X" and "Y" coordinates in table [Figure 2-44](#).
- 2.) Find first and second neighbors by calculating "X" and "Y" distance from the selected pad. [Figure 2-44](#) is sorted by "Y" coordinate, which might help locate the 4 close-neighbor candidates (if the pad is near the edge, it might end up with less than 4 close-neighbors).

Defining active pads:

Pad is active if it is currently in use and if it doesn't have "Vxx" in the name.

Figuring out number of active close-neighbor pads follow next rules:

- If the first neighbor is active, then we count it and also check if second neighbor (on the same side of selected pad) is active.
- If the first neighbor is not active, then we do not check the second on the same side.

## 2.4 Legend

The data in this chapter 2 match with the file TC38xpd\_IO\_Spirit\_v1.0.0.1.21.xml.

### Column "Ctrl.":

I = Input (for GPIO port lines with IOCR bit field Selection PCx = 0XXX<sub>B</sub>)

O = Output (for GPIO port lines the 'O' represents in most cases the port HWOUT function)

O0 = Output with IOCR bit field selection PCx = 1X000<sub>B</sub>

O1 = Output with IOCR bit field selection PCx = 1X001<sub>B</sub> (ALT1)

O2 = Output with IOCR bit field selection PCx = 1X010<sub>B</sub> (ALT2)

O3 = Output with IOCR bit field selection PCx = 1X011<sub>B</sub> (ALT3)

O4 = Output with IOCR bit field selection PCx = 1X100<sub>B</sub> (ALT4)

O5 = Output with IOCR bit field selection PCx = 1X101<sub>B</sub> (ALT5)

O6 = Output with IOCR bit field selection PCx = 1X110<sub>B</sub> (ALT6)

O7 = Output with IOCR bit field selection PCx = 1X111<sub>B</sub> (ALT7)

### Column "Buffer Type":

RFAST = Pad class RFAST (5V/3.3V)

FAST = Pad class FAST (5V/3.3V)

SLOW = Pad class SLOW (5V/3.3V)

LVDS\_TX = Pad class LVDS Transmit

LVDS\_RX = Pad class LVDS Receive

S = Pad class S (Analog Input overlaid with General Purpose Input)

D = Pad class D (Analog Input)

Porst = Porst input Pad

XTAL1 = XTAL1 input Pad

XTAL2 = XTAL2 input Pad

PU = with pull-up device connected during reset ( $\overline{\text{PORST}} = 0$ )

PU1 = with pull-up device connected during reset ( $\overline{\text{PORST}} = 0$ )<sup>1)</sup>

PU2 = with pull-up device connected during startup and reset, HighZ in Standby mode

PD = with pull-down device connected during reset ( $\overline{\text{PORST}} = 0$ )

PD1 = with pull-down device connected during reset ( $\overline{\text{PORST}} = 0$ )<sup>1)</sup>

PD2 = with pull-down device connected during startup and reset, HighZ in Standby mode

OD = open drain during reset ( $\overline{\text{PORST}} = 0$ )

ES = Supports Emergency Stop

ES1 = ES. ES can be overruled by VADC, control via P00\_PCSR

ES2 = ES. ES can be overruled by DXCPL - DAP over CAN physical layer, No overruling for DXCM - Debug over CAN message

ES3 = ES. ES can be overruled by JTAG mode if this pin is used as TDI

ES4 = ES. ES can be overruled by JTAG or Three Pin DAP mode

1) The default state of GPIOs (Px.y) during and after PORST active is controlled via HWCFG6 (P14.4). Pls. see also chapter PMS, HWCFG[6].

---

**Pin Definition and Functions Legend**

ES5 = ES. ES can be overruled by the Standby Controller - SCR - if implemented. Overruling can be disabled via the control register P33\_PCSR and P34\_PCSR

ES6 = ES. On LVDS TX pads the ES affects the pads only in CMOS mode, not in LVDS mode. Thus, only when LPCRx.TX\_EN selects the CMOS Mode, the output is switched off in the ES event

## 3 Electrical Specification

### 3.1 Parameter Interpretation

The parameters listed in this section partly represent the characteristics of the TC38x and partly its requirements on the system. To aid interpreting the parameters easily when evaluating them for a design, they are marked with an two-letter abbreviation in column "Symbol":

- **CC**  
Such parameters indicate **C**ontroller **C**haracteristics which are a distinctive feature of the TC38x and must be regarded for a system design.
- **SR**  
Such parameters indicate **S**ystem **R**equirements which must be provided by the microcontroller system in which the TC38x designed in.

## Electrical Specification Absolute Maximum Ratings

### 3.2 Absolute Maximum Ratings

Stresses above the values listed under “Absolute Maximum Ratings” may cause permanent damage to the device. This is a stress rating only and functional operation of the device at these or any other conditions above those indicated in the Operational Conditions of this specification is not implied. Exposure to absolute maximum rating conditions may affect device reliability.

**Table 3-1 Absolute Maximum Ratings**

Parameter	Symbol	Values			Unit	Note / Test Condition
		Min.	Typ.	Max.		
Storage Temperature	$T_{ST}$ SR	-65	-	150	°C	upto 65h @ $T_J = 150^\circ\text{C}$
Voltage at $V_{DD}$ power supply pins with respect to $V_{SS}$ <sup>1) 2)</sup>	$V_{DD}$ SR	-	-	1.65	V	upto 2.8h
		-	-	1.45	V	upto 72h
Voltage at $V_{DDP3}$ power supply pins with respect to $V_{SS}$	$V_{DDP3}$ SR	-	-	4.43	V	
Voltage at $V_{DDM}$ , $V_{EXT}$ , $V_{FLEX}$ and $V_{EVR SB}$ power supply pins with respect to $V_{SS}$	$V_{DDM}$ SR	-	-	6.75	V	upto 2.8h
		-	-	5.6	V	upto 72h
Voltage on all analog and class S input pins with respect to $V_{SS}$ <sup>3)</sup>	$V_{IN}$ SR	-0.7	-	6.75	V	
Voltage on all other input pins with respect to $V_{SS}$ <sup>3)</sup>	$V_{IN}$ SR	-0.7	-	6.75	V	
Input current on any pin during overload condition <sup>4) 5)</sup>	$I_{IN}$ SR	-10	-	10	mA	
Absolute maximum sum of all input circuit currents during overload condition. <sup>4)</sup>	$\Sigma I_{IN}$ SR	-100	-	100	mA	

- 1) Valid for cumulated for up to 2.8h and pulse forms followed a power supply switch on phase, where the rise and fall times are related to the system capacities and coils.
- 2) Due to EVRC output voltage oscillation during switch off phase  $V_{DD}$  can drop down to -0.72V. For  $V_{DD}$  an input level down to -0.72V during switch off phase will not cause any damage or reliability problem.
- 3) Voltages below  $V_{INmin}$  have no impact to the device reliability as long as the times and currents defined in section Pin Reliability in Overload for the affected pad(s) are not violated.
- 4) This parameter is an Absolute Maximum Rating. Exposure to Absolute Maximum Ratings for extended periods of time may damage the device.
- 5) The specified min. and max. values represent the current limits, which have to be maintained, in case of a short circuit condition on the output of any Fast, RFast, Slow and Class S pad, not being used during operation. This covers also output currents due to switching in operation for  $C_L=200\text{pF}$ .

### 3.3 Pin Reliability in Overload

When receiving signals from higher voltage devices, low-voltage devices experience overload currents and voltages that go beyond their own IO power supplies specification.

The following table defines overload conditions that will not cause any negative reliability impact if all the following conditions are met:

- allowed time interval (defined in Note column) for overload condition is not exceeded. If no time limit is defined the allowed time includes both 'Operation Lifetime hours' and 'Inactive Lifetime hours'. The number of hours in [Table 3-68](#) and [Table 3-69](#) are examples only and the applicable numbers are defined by the customer profiles accepted by Infineon.
- **Operating Conditions** are met for
  - pad supply levels
  - temperature

If a pin current is out of the **Operating Conditions** but within the overload parameters, then the parameters functionality of this pin as stated in the Operating Conditions can no longer be guaranteed. Operation is still possible in most cases but with relaxed parameters.

**Table 3-2 Overload Parameters**

Parameter	Symbol	Values			Unit	Note / Test Condition
		Min.	Typ.	Max.		
Input current on any digital pin during overload condition	$I_{IN}$	-5	-	5	mA	except LVDS pins
		-15 <sup>1)</sup>	-	15 <sup>1)</sup>	mA	except LVDS pins; limited to max. 20 pulses with 1ms pulse length
Input current on LVDS pin during overload condition	$I_{INLVDS}$	-3	-	3	mA	
Input current on analog input pin during overload condition	$I_{INANA}$	-3	-	3	mA	
		-5	-	5	mA	limited to 60h over lifetime
Absolute sum of all analog input currents for analog inputs during overload condition	$I_{INSA}$	-20	-	20	mA	
Absolute maximum sum of all input circuit currents during overload condition (digital and analog combined)	$\Sigma I_{INS}$	-100	-	100	mA	
Signal voltage over/undershoot at GPIOs	$V_{OUS}$	$V_{SS} - 2$	-	$V_{EXT/FLEX} + 2$	V	limited to 60h over lifetime; Valid for non LVDS and analog pads
Sum of all inactive device pin currents	$I_{IDS}$	-100	-	100	mA	
Static pin output current	$I_{OUT\ CC}$	-	-	2.5	mA	100% duty cycle; output driver = medium
		-	-	5	mA	100% duty cycle; output driver = strong

**Electrical Specification Pin Reliability in Overload**
**Table 3-2 Overload Parameters (cont'd)**

Parameter	Symbol	Values			Unit	Note / Test Condition
		Min.	Typ.	Max.		
Overload coupling factor for digital inputs, negative	$K_{OVDN}$ CC	-	-	$3 \cdot 10^{-4}$		Overload injected on GPIO non LVDS pad and affecting neighbor fast pads; $-5\text{mA} < I_{IN} < 0\text{mA}$
		-	-	$2 \cdot 10^{-3}$		Overload injected on GPIO non LVDS pad and affecting neighbor slow pads VGASTE1N and VGATE1P; $-5\text{mA} < I_{IN} < 0\text{mA}$
		-	-	$1 \cdot 10^{-4}$		Overload injected on GPIO non LVDS pad and affecting neighbor slow pads; $-5\text{mA} < I_{IN} < 0\text{mA}$
		-	-	0.8		Overload injected on LVDS RX pad and affecting neighbor LVDS pads
		-	-	0.5		Overload injected on LVDS TX pad and affecting neighbor LVDS pads
Overload coupling factor for digital inputs, positive	$K_{OVDP}$ CC	-	-	$1.5 \cdot 10^{-3}$		Overload injected on GPIO non LVDS pad and affecting neighbor GPIO non LVDS pads
		-	-	1		Overload injected on LVDS RX pad and affecting neighbor LVDS pads
		-	-	$5 \cdot 10^{-3}$		Overload injected on LVDS TX pad and affecting neighbor LVDS pads
Overload coupling factor for analog inputs, negative <sup>2)</sup>	$K_{OVAN}$ CC	-	-	$1 \cdot 10^{-4}$		Analog inputs overlaid with slow pads or pull down diagnostics; $-5\text{mA} < I_{IN} < 0\text{mA}$
		-	-	$1 \cdot 10^{-5}$		else; $-5\text{mA} < I_{IN} < 0\text{mA}$

## Electrical Specification Pin Reliability in Overload

Table 3-2 Overload Parameters (cont'd)

Parameter	Symbol	Values			Unit	Note / Test Condition
		Min.	Typ.	Max.		
Overload coupling factor for analog inputs, positive <sup>2)</sup>	$K_{OVAP\ CC}$	-	-	$2 \cdot 10^{-4}$		Analog inputs overlaid with slow pads or pull down diagnostics; $0\text{mA} < I_{IN} < 5\text{mA}$
		-	-	$2 \cdot 10^{-5}$		else; $0\text{mA} < I_{IN} < 5\text{mA}$

- 1) Reduced VADC / DSADC result accuracy and / or GPIO input levels ( $V_{IL}$  and  $V_{IH}$ ) can differ from specified parameters.
- 2) Overload coupling on analog inputs is caused by parasitic effects between pads, input multiplexers and surrounding structures. The given parameters have been verified for all permutations of channels. Also watch multiple connections of a pin to several channels.

## Electrical Specification Operating Conditions

### 3.4 Operating Conditions

The following operating conditions must not be exceeded in order to ensure correct operation and reliability of the TC38x. All parameters specified in the following tables refer to these operating conditions, unless otherwise noticed.

Digital supply voltages applied to the TC38x must be static regulated voltages.

All parameters specified in the following tables refer to these operating conditions (see table below), unless otherwise noticed in the Note / Test Condition column.

**Table 3-3 Operating Conditions**

Parameter	Symbol	Values			Unit	Note / Test Condition
		Min.	Typ.	Max.		
SRI frequency	$f_{SRI}$ SR	-	-	300	MHz	
CPU Frequency (All CPUs)	$f_{CPUx}$ SR	-	-	300	MHz	
PLL0 output frequency	$f_{PLL0}$ SR	20	-	300	MHz	
SPB frequency	$f_{SPB}$ SR	-	-	100	MHz	
FSI2 frequency	$f_{FSI2}$ SR	-	-	300	MHz	
FSI frequency	$f_{FSI}$ SR	20	-	100	MHz	
GTM frequency	$f_{GTM}$ SR	-	-	200	MHz	
STM frequency	$f_{STM}$ SR	-	-	100	MHz	
ERAY frequency	$f_{ERAY}$ SR	-	80	-	MHz	
VADC frequency	$f_{ADC}$ SR	-	-	160	MHz	
ASCLIN Operating Frequency	$f_{ASCLINx}$ SR	-	-	200	MHz	
CAN frequency	$f_{CAN}$ SR	-	-	80	MHz	
I2C frequency	$f_{I2C}$ SR	-	-	100	MHz	
Operating MSC Frequency	$f_{MSC}$ SR	-	-	200	MHz	
PLL1 output frequency from PER PLL	$f_{PLL1}$ SR	20	-	320	MHz	
PLL2 output frequency from PER PLL	$f_{PLL2}$ SR	20	-	200	MHz	
QSPI Frequency	$f_{QSPI}$ SR	-	-	200	MHz	
ADAS clock frequency	$f_{ADAS}$ CC	200	-	300	MHz	
MCANH frequency	$f_{MCANH}$ CC	-	-	100	MHz	
GETH frequency	$f_{GETH}$ CC	100	-	150	MHz	
Ambient Temperature	$T_A$ SR	-40	-	125	°C	valid for all SAK products
		-40	-	150	°C	valid for all SAL products with package
		-40	-	170	°C	valid for all SAL products without package

**Electrical Specification Operating Conditions**
**Table 3-3 Operating Conditions (cont'd)**

Parameter	Symbol	Values			Unit	Note / Test Condition
		Min.	Typ.	Max.		
Junction Temperature	$T_J$ SR	-40	-	150	°C	valid for all SAK products
		-40	-	170	°C	valid for all SAL products
Core Supply Voltage	$V_{DD}$ SR	1.125 <sup>1)</sup>	1.25	1.375 <sup>2)</sup>	V	
ADC analog supply voltage	$V_{DDM}$ SR	2.97	5.0	5.5 <sup>3)</sup>	V	
Digital external supply voltage for pads and EVR	$V_{EXT}$ SR	4.5	5.0	5.5 <sup>3)</sup>	V	Nominal 5V Pad / Port Pin supply range. 5V pad parameters are valid.
		2.97	3.3	3.63	V	Nominal 3.3V Pad / Port Pin supply range with VDDP3 supplied externally and EVR33 inactive. 3.3V pad parameters are valid.
		3.6	-	4.5	V	Flash configured in cranking mode; Flash read operation with reduced performance. EVR33 active in low voltage mode. 3.3V pad parameters are valid.
		2.97	-	3.6	V	Incase EVR33 is active, Flash configured in sleep mode and execution switched to RAM. 3.3V pad parameters are valid.
Digital supply voltage for Flex port	$V_{FLEX}$ SR	2.97	-	4.0	V	3.3V pad parameters are valid
		4.5	5.0	5.5 <sup>3)</sup>	V	5V pad parameters are valid
Digital supply voltage for Flash	$V_{DDP3}$ SR	2.97	3.3	3.63 <sup>4)</sup>	V	
		2.6	-	3.63	V	Flash configured in cranking mode; Flash read operation with reduced performance.
Digital ground voltage	$V_{SS}$ SR	0	-	-	V	
Analog ground voltage for $V_{DDM}$	$V_{SSM}$ CC	-0.1	0	0.1	V	

## Electrical Specification Operating Conditions

**Table 3-3 Operating Conditions (cont'd)**

Parameter	Symbol	Values			Unit	Note / Test Condition
		Min.	Typ.	Max.		
Digital external supply voltage for EVR and during Standby mode	$V_{\text{EVRSB}}$ SR	2.97 <sup>5)</sup>	-	5.5	V	
Voltage to ensure defined pad states	$V_{\text{DDPPA}}$ CC	1.3 <sup>6)</sup>	-	-	V	

- 1) For  $V_{\text{DD}}$   $1.08\text{V} \leq V_{\text{DD}} < 1.125\text{V}$  operation is still possible but with relaxed parameters.
- 2) Voltage overshoot to 1.69V is permissible, provided the duration is less than 2h cumulated. Reduced ADC accuracy and leakage is increased.
- 3) Voltage overshoot to 6.5V is permissible, provided the duration is less than 2h cumulated. Reduced ADC accuracy and leakage is increased.
- 4) Voltage overshoot to 4.29V is permissible, provided the duration is less than 2h cumulated. Reduced ADC accuracy and leakage is increased.
- 5)  $V_{\text{EVRSB}}$  supply voltage can drop down upto 2.6V during Standby mode. It is required to have a capacitor of 100nF on  $V_{\text{EVRSB}}$  supply pin.
- 6) HWCFG[6] pin is latched and pull-up or tristate is activated at Port pins when VEXT has reached this level.

**Limitation of Supply Voltage over Time**

The maximum operation voltage for  $V_{\text{EXT/FLEX/DDM}}$  supply rails is limited over the complete lifetime.

The following voltage profile is an example. Application specific voltage profiles need to be aligned and approved by Infineon Technologies for the fulfillment of quality and reliability targets.

**Table 3-4 Example Voltage Profile**

$V_{\text{EXT/FLEX/DDM}}^{\text{=}}$	Duration [h]
$5.4\text{ V} < V_{\text{EXT/FLEX/DDM}} \leq 5.5\text{ V}$	$\leq 5\%$ of lifetime
$5.15\text{ V} < V_{\text{EXT/FLEX/DDM}} \leq 5.4\text{ V}$	$\leq 15\%$ of lifetime
$4.85\text{ V} < V_{\text{EXT/FLEX/DDM}} \leq 5.15\text{ V}$	$\leq 60\%$ of lifetime
$4.6\text{ V} < V_{\text{EXT/FLEX/DDM}} \leq 4.85\text{ V}$	$\leq 15\%$ of lifetime
$4.5\text{ V} < V_{\text{EXT/FLEX/DDM}} \leq 4.6\text{ V}$	$\leq 5\%$ of lifetime

The maximum operation voltage for  $V_{\text{DD}}$  supply rails is limited over the complete lifetime.

The following voltage profile is an example. Application specific voltage profiles need to be aligned and approved by Infineon Technologies for the fulfillment of quality and reliability targets.

**Table 3-5 Example Voltage Profile**

$V_{\text{DD}}^{\text{=}}$	Duration [h]
$1.325\text{ V} < V_{\text{DD}} \leq 1.375\text{ V}$	$\leq 5\%$ of lifetime
$1.275\text{ V} < V_{\text{DD}} \leq 1.325\text{ V}$	$\leq 15\%$ of lifetime
$1.225\text{ V} < V_{\text{DD}} \leq 1.275\text{ V}$	$\leq 60\%$ of lifetime
$1.175\text{ V} < V_{\text{DD}} \leq 1.225\text{ V}$	$\leq 15\%$ of lifetime
$1.125\text{ V} < V_{\text{DD}} \leq 1.175\text{ V}$	$\leq 5\%$ of lifetime

### 3.5 5 V / 3.3 V switchable Pads

Pad classes slow GPIO and fast GPIO support both Automotive Level (AL) or TTL level (TTL) operation. Parameters are defined for AL operation and degrade in TTL operation.

**Table 3-6  $\overline{\text{PORST}}$  Pad**

Parameter	Symbol	Values			Unit	Note / Test Condition
		Min.	Typ.	Max.		
$\overline{\text{PORST}}$ pad Output current	$I_{\text{PORST}}$ CC	13	-	-	mA	$V_{\text{EXT}} = 2.97\text{V}$ ; $V_{\text{PORST}} = 0.9\text{V}$
Spike filter always blocked pulse duration	$t_{\text{SF1}}$ CC	-	-	80	ns	
Spike filter pass-through blocked pulse duration	$t_{\text{SF2}}$ CC	260	-	-	ns	without additional $\overline{\text{PORST}}$ Digital Filter active ( $\text{PORSTDF} = 0$ ).
Input hysteresis <sup>1)</sup>	$HYS$ CC	$0.055 * V_{\text{EXT}}$	-	-	V	non of the neighbor pads are used as output; TTL (degraded, used for CIF)
Pull-down current <sup>2)</sup>	$I_{\text{PDL}}$ CC	-	-	130	$\mu\text{A}$	$V_{\text{IH}}$ ; TTL (degraded, used for CIF)
		15	-	-	$\mu\text{A}$	$V_{\text{IL}}$ ; TTL (degraded, used for CIF)
Input leakage current	$I_{\text{OZ}}$ CC	-450	-	450	nA	$T_{\text{J}} \leq 150^{\circ}\text{C}$ ; $(0.1 * V_{\text{EXT}}) < V_{\text{IN}} < (0.9 * V_{\text{EXT}})$
		-500	-	500	nA	$T_{\text{J}} \leq 150^{\circ}\text{C}$ ; else
		-900	-	900	nA	$T_{\text{J}} \leq 170^{\circ}\text{C}$ ; $(0.1 * V_{\text{EXT}}) < V_{\text{IN}} < (0.9 * V_{\text{EXT}})$
		-950	-	950	nA	$T_{\text{J}} \leq 170^{\circ}\text{C}$ ; else
Input high voltage level	$V_{\text{IH}}$ SR	1.4	-	-	V	TTL (degraded, used for CIF); $V_{\text{EXT}} = 2.97\text{V}$
		2.0	-	-	V	TTL; $V_{\text{EXT}} = 4.5\text{V}$
Input low voltage level	$V_{\text{IL}}$ SR	-	-	0.5	V	TTL (degraded, used for CIF); $V_{\text{EXT}} = 2.97\text{V}$
		-	-	0.8	V	TTL; $V_{\text{EXT}} = 4.5\text{V}$
Pin capacitance	$C_{\text{IO}}$ CC	-	2	3	pF	in addition 2.5pF from package to be added

1) Hysteresis is implemented to avoid metastable states and switching due to internal ground bounce. It can't be guaranteed that it suppresses switching due to external system noise.

2) Values for Pull-down resistor is defined via parameter  $R_{\text{MDD}}$  in table VADC 5V.

**Electrical Specification 5 V / 3.3 V switchable Pads**
**Table 3-7 Fast 5V GPIO**

Parameter	Symbol	Values			Unit	Note / Test Condition
		Min.	Typ.	Max.		
On-Resistance of pad output	$R_{DSON}$ CC	125	225	320	Ohm	medium driver; $I_{OH/OL} = 2\text{mA}$
		31	55	80	Ohm	strong driver; $I_{OH/OL} = 8\text{mA}$
Rise / Fall time <sup>1) 2)</sup>	$t_{RF}$ CC	1.6	-	3.2	ns	$C_L = 25\text{pF}$ ; driver = strong sharp edge; from 0.2 * $V_{EXT/FLEX/EVRSB}$ to 0.8 * $V_{EXT/FLEX/EVRSB}$
		$4+0.55 \cdot C_L$	$4+0.75 \cdot C_L$	$12+1.0 \cdot C_L$	ns	driver = medium; $C_L \leq 200\text{pF}$
		$1.0+0.18 \cdot C_L$	$2.5+0.27 \cdot C_L$	$5.0+0.35 \cdot C_L$	ns	driver = strong edge = medium; $C_L \leq 200\text{pF}$
		$0.5+0.08 \cdot C_L$	$0.5+0.11 \cdot C_L$	$1.0+0.17 \cdot C_L$	ns	driver = strong edge = sharp ; $C_L \leq 200\text{pF}$
Asymmetry of sending	$t_{TX\_ASYM}$ CC	-1	-	1	ns	valid for all data rates excluding clock tolerance
Input frequency	$f_{IN}$ CC	-	-	160	MHz	
Input hysteresis <sup>3)</sup>	HYS CC	0.09 * $V_{EXT/FLEX/EVRSB}$	-	-	V	non of the neighbor pads are used as output; AL
		0.075 * $V_{EXT/FLEX/EVRSB}$	-	-	V	non of the neighbor pads are used as output; TTL
		75	-	-	mV	two of the neighbor pads are used as output with driver=strong and edge=sharp; AL
Pull-up current <sup>4)</sup>	$I_{PUH}$ CC	30	-	-	$\mu\text{A}$	$V_{IH}$ ; AL or TTL
		-	-	130	$\mu\text{A}$	$V_{IL}$ ; AL or TTL
Pull-down current <sup>5)</sup>	$I_{PDL}$ CC	-	-	130	$\mu\text{A}$	$V_{IH}$ ; AL or TTL
		30	-	-	$\mu\text{A}$	$V_{IL}$ ; AL
		28	-	-	$\mu\text{A}$	$V_{IL}$ ; TTL

**Electrical Specification 5 V / 3.3 V switchable Pads**
**Table 3-7 Fast 5V GPIO (cont'd)**

Parameter	Symbol	Values			Unit	Note / Test Condition
		Min.	Typ.	Max.		
Input leakage current	$I_{OZ}$ CC	-1100	-	1100	nA	$T_J \leq 150^\circ\text{C}$ ; $(0.1 * V_{EXT/FLEX/EVRSB}) < V_{IN} < (0.9 * V_{EXT/FLEX/EVRSB})$
		-2500	-	2500	nA	$T_J \leq 150^\circ\text{C}$ ; $(0.1 * V_{EXT/FLEX}) < V_{IN} < (0.9 * V_{EXT/FLEX})$ ; LVDS_TX / Fast pad type
		-6000	-	6000	nA	$T_J \leq 150^\circ\text{C}$ ; LVDS_RX / Fast pad type ; else
		-3200	-	3200	nA	$T_J \leq 150^\circ\text{C}$ ; LVDS_TX / Fast pad type ; else
		-1500	-	1500	nA	$T_J \leq 150^\circ\text{C}$ ; else
		-2000	-	2000	nA	$T_J \leq 170^\circ\text{C}$ ; $(0.1 * V_{EXT/FLEX/EVRSB}) < V_{IN} < (0.9 * V_{EXT/FLEX/EVRSB})$
		-4000	-	4000	nA	$T_J \leq 170^\circ\text{C}$ ; $(0.1 * V_{EXT/FLEX}) < V_{IN} < (0.9 * V_{EXT/FLEX})$ ; LVDS_TX / Fast pad type
		-13500	-	13500	nA	$T_J \leq 170^\circ\text{C}$ ; LVDS_RX / Fast pad type ; else
		-5100	-	5100	nA	$T_J \leq 170^\circ\text{C}$ ; LVDS_TX / Fast pad type ; else
-2500	-	2500	nA	$T_J \leq 170^\circ\text{C}$ ; else		
Input high voltage level	$V_{IH}$ SR	0.7 * $V_{EXT/FLEX/EVRSB}$	-	-	V	AL
		2.0	-	-	V	TTL
Input low voltage level	$V_{IL}$ SR	-	-	0.44 * $V_{EXT/FLEX/EVRSB}$	V	AL
		-	-	0.8	V	TTL
Input low threshold variation	$V_{ILD}$ SR	-50	-	50	mV	max. variation of 1ms; $V_{EXT/FLEX/EVRSB} =$ constant; AL
Pin capacitance	$C_{IO}$ CC	-	2	3	pF	in addition 2.5pF from package to be added
Pad set-up time to get an software update of the configuration active	$t_{SET}$ CC	-	-	100	ns	

1) In the formulas the value of  $C_L$  needs to be entered in pF to obtain results in ns.

2) Rise / fall times are defined 10% - 90% of pad supply voltage.

**Electrical Specification 5 V / 3.3 V switchable Pads**

- 3) Hysteresis is implemented to avoid metastable states and switching due to internal ground bounce. It can't be guaranteed that it suppresses switching due to external system noise.
- 4) Values for Pull-up resistor is defined via parameter  $R_{MDU}$  in table VADC 5V.
- 5) Values for Pull-down resistor is defined via parameter  $R_{MDD}$  in table VADC 5V.

**Table 3-8 Fast 3.3V GPIO**

Parameter	Symbol	Values			Unit	Note / Test Condition
		Min.	Typ.	Max.		
On-Resistance of pad output	$R_{DSON}$ CC	125	225	320	Ohm	medium driver; $I_{OH/OL} = 2mA$
		31	55	80	Ohm	strong driver; $I_{OH/OL} = 8mA$
Rise / Fall time <sup>1) 2)</sup>	$t_{RF}$ CC	1.6	-	4.5	ns	$C_L = 25pF$ ; driver = strong sharp edge; from 0.2 * $V_{EXT/FLEX/EVRSB}$ to 0.8 * $V_{EXT/FLEX/EVRSB}$
		-	-	5	ns	$C_L = 25pF$ ; driver = strong sharp edge; from 0.8V to 2.0V (RMII)
		$2+0.57*C_L$	$5.5+0.75*C_L$	$10+1.25*C_L$	ns	driver = medium; $C_L \leq 200pF$
		$1.5+0.18*C_L$	$1.5+0.28*C_L$	$8+0.4*C_L$	ns	driver = strong edge = medium; $C_L \leq 200pF$
		$0.75+0.08*C_L$	$0.75+0.11*C_L$	$2.5+0.21*C_L$	ns	driver = strong edge = sharp ; $C_L \leq 200pF$
		-	-	-	-	-
Asymmetry of sending	$t_{TX\_ASYM}$ CC	-1	-	1	ns	valid for all data rates excluding clock tolerance
Input frequency	$f_{IN}$ CC	-	-	160	MHz	
Input hysteresis <sup>3)</sup>	HYS CC	0.055 * $V_{EXT/FLEX/EVRSB}$	-	-	V	non of the neighbor pads are used as output; AL
		0.09 * $V_{EXT/FLEX/EVRSB}$	-	-	V	non of the neighbor pads are used as output; TTL
		0.055 * $V_{EXT/FLEX/EVRSB}$	-	-	V	non of the neighbor pads are used as output;TTL (degraded, used for CIF)
		125	-	-	mV	two of the neighbor pads are used as output with driver=strong and edge=sharp; AL

**Electrical Specification 5 V / 3.3 V switchable Pads**
**Table 3-8 Fast 3.3V GPIO (cont'd)**

Parameter	Symbol	Values			Unit	Note / Test Condition
		Min.	Typ.	Max.		
Pull-up current <sup>4)</sup>	$I_{PUH}$ CC	17	-	-	μA	$V_{IH}$ ; AL and TTL (degraded, used for CIF)
		11	-	-	μA	$V_{IH}$ ; TTL
		-	-	80	μA	$V_{IL}$ ; AL and TTL and TTL (degraded, used for CIF)
Pull-down current <sup>5)</sup>	$I_{PDL}$ CC	-	-	105	μA	$V_{IH}$ ; AL and TTL (degraded, used for CIF)
		-	-	115	μA	$V_{IH}$ ; TTL
		19	-	-	μA	$V_{IL}$ ; AL and TTL
		15	-	-	μA	$V_{IL}$ ; TTL (degraded, used for CIF)
Input leakage current	$I_{OZ}$ CC	-1100	-	1100	nA	$T_J \leq 150^\circ\text{C}$ ; (0.1 * $V_{EXT/FLEX/EVRSB}$ ) < $V_{IN}$ < (0.9 * $V_{EXT/FLEX/EVRSB}$ )
		-2500	-	2500	nA	$T_J \leq 150^\circ\text{C}$ ; (0.1 * $V_{EXT/FLEX}$ ) < $V_{IN}$ < (0.9 * $V_{EXT/FLEX}$ ) ; LVDS_TX / Fast pad type
		-6000	-	6000	nA	$T_J \leq 150^\circ\text{C}$ ; LVDS_RX / Fast pad type ; else
		-3200	-	3200	nA	$T_J \leq 150^\circ\text{C}$ ; LVDS_TX / Fast pad type ; else
		-1500	-	1500	nA	$T_J \leq 150^\circ\text{C}$ ; else
		-2000	-	2000	nA	$T_J \leq 170^\circ\text{C}$ ; (0.1 * $V_{EXT/FLEX/EVRSB}$ ) < $V_{IN}$ < (0.9 * $V_{EXT/FLEX/EVRSB}$ )
		-4000	-	4000	nA	$T_J \leq 170^\circ\text{C}$ ; (0.1 * $V_{EXT/FLEX}$ ) < $V_{IN}$ < (0.9 * $V_{EXT/FLEX}$ ) ; LVDS_TX / Fast pad type
		-13500	-	13500	nA	$T_J \leq 170^\circ\text{C}$ ; LVDS_RX / Fast pad type ; else
		-5100	-	5100	nA	$T_J \leq 170^\circ\text{C}$ ; LVDS_TX / Fast pad type ; else
-2500	-	2500	nA	$T_J \leq 170^\circ\text{C}$ ; else		

**Electrical Specification 5 V / 3.3 V switchable Pads**
**Table 3-8 Fast 3.3V GPIO (cont'd)**

Parameter	Symbol	Values			Unit	Note / Test Condition
		Min.	Typ.	Max.		
Input high voltage level	$V_{IH}$ SR	0.7 *	-	-	V	AL
		$V_{EXT/FLEX/E}$ $V_{RSB}$	-	-	V	TTL
		2.0	-	-	V	TTL (degraded, used for CIF)
Input low voltage level	$V_{IL}$ SR	-	-	0.42 *	V	AL
		-	-	$V_{EXT/FLEX/E}$ $V_{RSB}$	V	TTL
		-	-	0.8	V	TTL (degraded, used for CIF)
Input low/high voltage level	$V_{ILH}$ SR	1.0	-	1.9	V	RGMII; no hysteresis available
Input low threshold variation	$V_{ILD}$ SR	-33	-	33	mV	max. variation of 1ms; $V_{EXT/FLEX/EVRSB} =$ constant; AL
Pin capacitance	$C_{IO}$ CC	-	2	3	pF	in addition 2.5pF from package to be added
Pad set-up time to get an software update of the configuration active	$t_{SET}$ CC	-	-	100	ns	

- 1) In the formulas the value of  $C_L$  needs to be entered in pF to obtain results in ns.
- 2) Rise / fall times are defined 10% - 90% of pad supply voltage.
- 3) Hysteresis is implemented to avoid metastable states and switching due to internal ground bounce. It can't be guaranteed that it suppresses switching due to external system noise.
- 4) Values for Pull-up resistor is defined via parameter  $R_{MDU}$  in table VADC 5V.
- 5) Values for Pull-down resistor is defined via parameter  $R_{MDD}$  in table VADC 5V.

**Table 3-9 Slow 5V GPIO**

Parameter	Symbol	Values			Unit	Note / Test Condition
		Min.	Typ.	Max.		
On-Resistance of pad output	$R_{DSON}$ CC	125	225	320	Ohm	medium driver; $I_{OH/OL} = 2mA$
Rise / Fall time <sup>1) 2)</sup>	$t_{RF}$ CC	$4+0.55*C_L$	$4+0.75*C_L$	$12+1*C_L$	ns	driver = medium edge = medium ; $C_L \leq 200pF$
		$1.5+0.25*C_L$	$2.5+0.40*C_L$	$7+0.55*C_L$	ns	driver = medium edge = sharp ; $C_L \leq 200pF$
Asymmetry of sending	$t_{TX\_ASYM}$ CC	-1	-	1	ns	valid for all data rates excluding clock tolerance
Input frequency	$f_{IN}$ CC	-	-	160	MHz	

**Electrical Specification 5 V / 3.3 V switchable Pads**
**Table 3-9 Slow 5V GPIO (cont'd)**

Parameter	Symbol	Values			Unit	Note / Test Condition
		Min.	Typ.	Max.		
Input hysteresis <sup>3)</sup>	$I_{HYS}$ CC	0.09 * $V_{EXT/FLEX/E}$ VRSB	-	-	V	non of the neighbor pads are used as output; AL
		0.075 * $V_{EXT/FLEX/E}$ VRSB	-	-	V	non of the neighbor pads are used as output; TTL
		75	-	-	mV	two of the neighbor pads are used as output with driver=strong and edge=sharp; AL
Pull-up current <sup>4)</sup>	$I_{PUH}$ CC	30	-	-	$\mu$ A	$V_{IH}$ ; AL or TTL; except VGATE1P; except VGATE1N and $T_J > 150^\circ\text{C}$
		-	-	130	$\mu$ A	$V_{IL}$ ; AL or TTL; except VGATE1P; except VGATE1N and $T_J > 150^\circ\text{C}$
Pull-down current <sup>5)</sup>	$I_{PDL}$ CC	-	-	130	$\mu$ A	$V_{IH}$ ; AL or TTL
		30	-	-	$\mu$ A	$V_{IL}$ ; AL
		28	-	-	$\mu$ A	$V_{IL}$ ; TTL
Input leakage current	$I_{OZ}$ CC	-300	-	300	nA	$T_J \leq 150^\circ\text{C}$ ; $(0.1 * V_{EXT/FLEX/EVRSB}) < V_{IN} < (0.9 * V_{EXT/FLEX/EVRSB})$
		-400	-	400	nA	$T_J \leq 150^\circ\text{C}$ ; else
		-600	-	600	nA	$T_J \leq 170^\circ\text{C}$ ; $(0.1 * V_{EXT/FLEX/EVRSB}) < V_{IN} < (0.9 * V_{EXT/FLEX/EVRSB})$
		-750	-	750	nA	$T_J \leq 170^\circ\text{C}$ ; else
		-18000	-	18000	nA	P32.0 and P32.1; $T_J \leq 150^\circ\text{C}$
		-38000	-	38000	nA	P32.0 and P32.1; $T_J \leq 170^\circ\text{C}$
Input high voltage level	$V_{IH}$ SR	0.7 * $V_{EXT/FLEX/E}$ VRSB	-	-	V	AL
		2.0	-	-	V	TTL
Input low voltage level	$V_{IL}$ SR	-	-	0.44 * $V_{EXT/FLEX/E}$ VRSB	V	AL
		-	-	0.8	V	TTL

**Electrical Specification 5 V / 3.3 V switchable Pads**
**Table 3-9 Slow 5V GPIO (cont'd)**

Parameter	Symbol	Values			Unit	Note / Test Condition
		Min.	Typ.	Max.		
Input low threshold variation	$V_{ILD}$ SR	-50	-	50	mV	max. variation of 1ms; $V_{EXT/FLEX/EVRSB} =$ constant; AL
Pin capacitance	$C_{IO}$ CC	-	2	3	pF	in addition 2.5pF from package to be added
Pad set-up time to get an software update of the configuration active	$t_{SET}$ CC	-	-	100	ns	

- 1) In the formulas the value of  $C_L$  needs to be entered in pF to obtain results in ns.
- 2) Rise / fall times are defined 10% - 90% of pad supply voltage.
- 3) Hysteresis is implemented to avoid metastable states and switching due to internal ground bounce. It can't be guaranteed that it suppresses switching due to external system noise.
- 4) Values for Pull-up resistor is defined via parameter  $R_{MDU}$  in table VADC 5V.
- 5) Values for Pull-down resistor is defined via parameter  $R_{MDD}$  in table VADC 5V.

**Table 3-10 Slow 3.3V GPIO**

Parameter	Symbol	Values			Unit	Note / Test Condition
		Min.	Typ.	Max.		
On-Resistance of pad output	$R_{DSON}$ CC	125	225	320	Ohm	medium driver; $I_{OH/OL} =$ 2mA
Rise / Fall time <sup>1) 2)</sup>	$t_{RF}$ CC	$2+0.57 \cdot C_L$	$5.5+0.75 \cdot C_L$	$10+1.25 \cdot C_L$	ns	driver = medium edge = medium ; $C_L \leq 200$ pF
		$2+0.30 \cdot C_L$	$3.5+0.50 \cdot C_L$	$5+0.70 \cdot C_L$	ns	driver = medium edge = sharp ; $C_L \leq 200$ pF
Asymmetry of sending	$t_{TX\_ASYM}$ CC	-1	-	1	ns	valid for all data rates excluding clock tolerance
Input frequency	$f_{IN}$ CC	-	-	160	MHz	
Input hysteresis <sup>3)</sup>	$HYS$ CC	$0.055 \cdot V_{EXT/FLEX/EVRSB}$	-	-	V	non of the neighbor pads are used as output; AL
		$0.09 \cdot V_{EXT/FLEX/EVRSB}$	-	-	V	non of the neighbor pads are used as output; TTL
		$0.055 \cdot V_{EXT/FLEX/EVRSB}$	-	-	V	non of the neighbor pads are used as output;TTL (degraded, used for CIF)
		125	-	-	mV	two of the neighbor pads are used as output with driver=strong and edge=sharp; AL

**Electrical Specification 5 V / 3.3 V switchable Pads**
**Table 3-10 Slow 3.3V GPIO (cont'd)**

Parameter	Symbol	Values			Unit	Note / Test Condition
		Min.	Typ.	Max.		
Pull-up current <sup>4)</sup>	$I_{PUH}$ CC	17	-	-	$\mu$ A	$V_{IH}$ ; AL and TTL (degraded, used for CIF); except VGATE1P; except VGATE1N and $T_J > 150^\circ\text{C}$
		11	-	-	$\mu$ A	$V_{IH}$ ; TTL; except VGATE1P; except VGATE1N and $T_J > 150^\circ\text{C}$
		-	-	80	$\mu$ A	$V_{IL}$ ; AL and TTL and TTL (degraded, used for CIF); except VGATE1P; except VGATE1N and $T_J > 150^\circ\text{C}$
Pull-down current <sup>5)</sup>	$I_{PDL}$ CC	-	-	105	$\mu$ A	$V_{IH}$ ; AL and TTL (degraded, used for CIF)
		-	-	115	$\mu$ A	$V_{IH}$ ; TTL
		19	-	-	$\mu$ A	$V_{IL}$ ; AL and TTL
		15	-	-	$\mu$ A	$V_{IL}$ ; TTL (degraded, used for CIF)
Input leakage current	$I_{OZ}$ CC	-300	-	300	nA	$T_J \leq 150^\circ\text{C}$ ; ( $0.1 * V_{EXT/FLEX/EVRSB} < V_{IN} < (0.9 * V_{EXT/FLEX/EVRSB})$ )
		-400	-	400	nA	$T_J \leq 150^\circ\text{C}$ ; else
		-600	-	600	nA	$T_J \leq 170^\circ\text{C}$ ; ( $0.1 * V_{EXT/FLEX/EVRSB} < V_{IN} < (0.9 * V_{EXT/FLEX/EVRSB})$ )
		-750	-	750	nA	$T_J \leq 170^\circ\text{C}$ ; else
		-18000	-	18000	nA	P32.0 and P32.1; $T_J \leq 150^\circ\text{C}$
		-38000	-	38000	nA	P32.0 and P32.1; $T_J \leq 170^\circ\text{C}$
Input high voltage level	$V_{IH}$ SR	$0.7 * V_{EXT/FLEX/EVRSB}$	-	-	V	AL
		2.0	-	-	V	TTL
		1.4	-	-	V	TTL (degraded, used for CIF)

**Electrical Specification 5 V / 3.3 V switchable Pads**
**Table 3-10 Slow 3.3V GPIO (cont'd)**

Parameter	Symbol	Values			Unit	Note / Test Condition
		Min.	Typ.	Max.		
Input low voltage level	$V_{IL}$ SR	-	-	0.42 * $V_{EXT/FLEX/EVRSB}$	V	AL
		-	-	0.8	V	TTL
		-	-	0.5	V	TTL (degraded, used for CIF)
Input low/high voltage level	$V_{ILH}$ SR	1.0	-	1.9	V	RGMII; no hysteresis available
Input low threshold variation	$V_{ILD}$ SR	-33	-	33	mV	max. variation of 1ms; $V_{EXT/FLEX/EVRSB} =$ constant; AL
Pin capacitance	$C_{IO}$ CC	-	2	3	pF	in addition 2.5pF from package to be added
Pad set-up time to get an software update of the configuration active	$t_{SET}$ CC	-	-	100	ns	

- 1) In the formulas the value of  $C_L$  needs to be entered in pF to obtain results in ns.
- 2) Rise / fall times are defined 10% - 90% of pad supply voltage.
- 3) Hysteresis is implemented to avoid metastable states and switching due to internal ground bounce. It can't be guaranteed that it suppresses switching due to external system noise.
- 4) Values for Pull-up resistor is defined via parameter  $R_{MDU}$  in table VADC 5V.
- 5) Values for Pull-down resistor is defined via parameter  $R_{MDD}$  in table VADC 5V.

**Table 3-11 RFast 5V GPIO**

Parameter	Symbol	Values			Unit	Note / Test Condition
		Min.	Typ.	Max.		
On-Resistance of pad output	$R_{DSON}$ CC	125	225	320	Ohm	medium driver; $I_{OH/OL} = 2\text{mA}$
		31	55	80	Ohm	strong driver; $I_{OH/OL} = 8\text{mA}$
Rise / Fall time <sup>1) 2)</sup>	$t_{RF}$ CC	1.6	-	3.2	ns	$C_L = 25\text{pF}$ ; driver = strong sharp edge; from $0.2 * V_{FLEX}$ to $0.8 * V_{FLEX}$
		$4+0.55*C_L$	$4+0.75*C_L$	$12+1.0*C_L$	ns	driver = medium; $C_L \leq 200\text{pF}$
		$1.0+0.18*C_L$	$2.5+0.27*C_L$	$5.0+0.35*C_L$	ns	driver = strong edge = medium; $C_L \leq 200\text{pF}$
		$0.5+0.08*C_L$	$0.5+0.11*C_L$	$1.0+0.17*C_L$	ns	driver = strong edge = sharp ; $C_L \leq 200\text{pF}$
Asymmetry of sending	$t_{TX\_ASYM}$ CC	-0.5	-	0.5	ns	valid for all data rates excluding clock tolerance

**Electrical Specification 5 V / 3.3 V switchable Pads**
**Table 3-11 RFast 5V GPIO (cont'd)**

Parameter	Symbol	Values			Unit	Note / Test Condition
		Min.	Typ.	Max.		
Input frequency	$f_{IN}$ CC	-	-	160	MHz	
Input hysteresis <sup>3)</sup>	$HYS$ CC	0.09 * $V_{FLEX}$	-	-	V	non of the neighbor pads are used as output; AL
		0.075 * $V_{FLEX}$	-	-	V	non of the neighbor pads are used as output; TTL
		75	-	-	mV	two of the neighbor pads are used as output with driver=strong and edge=sharp; AL
Pull-up current <sup>4)</sup>	$I_{PUH}$ CC	30	-	-	$\mu$ A	$V_{IH}$ ; AL or TTL
		-	-	130	$\mu$ A	$V_{IL}$ ; AL or TTL
Pull-down current <sup>5)</sup>	$I_{PDL}$ CC	-	-	130	$\mu$ A	$V_{IH}$ ; AL or TTL
		30	-	-	$\mu$ A	$V_{IL}$ ; AL
		28	-	-	$\mu$ A	$V_{IL}$ ; TTL
Input leakage current	$I_{OZ}$ CC	-1700	-	1700	nA	$T_J \leq 150^\circ\text{C}$ ; (0.1 * $V_{FLEX}$ ) < $V_{IN}$ < (0.9 * $V_{FLEX}$ )
		-2100	-	2100	nA	$T_J \leq 150^\circ\text{C}$ ; else
		-3000	-	3000	nA	$T_J \leq 170^\circ\text{C}$ ; (0.1 * $V_{FLEX}$ ) < $V_{IN}$ < (0.9 * $V_{FLEX}$ )
		-4000	-	4000	nA	$T_J \leq 170^\circ\text{C}$ ; else
Input high voltage level	$V_{IH}$ SR	0.7 * $V_{FLEX}$	-	-	V	AL
		2.0	-	-	V	TTL
Input low voltage level	$V_{IL}$ SR	-	-	0.44 * $V_{FLEX}$	V	AL
		-	-	0.8	V	TTL
Input low threshold variation	$V_{ILD}$ SR	-50	-	50	mV	max. variation of 1ms; $V_{FLEX}$ = constant; AL
Pin capacitance	$C_{IO}$ CC	-	2	3.5	pF	in addition 2.5pF from package to be added
Pad set-up time to get an software update of the configuration active	$t_{SET}$ CC	-	-	100	ns	

1) In the formulas the value of  $C_L$  needs to be entered in pF to obtain results in ns.

2) Rise / fall times are defined 10% - 90% of pad supply voltage.

3) Hysteresis is implemented to avoid metastable states and switching due to internal ground bounce. It can't be guaranteed that it suppresses switching due to external system noise.

4) Values for Pull-up resistor is defined via parameter  $R_{MDU}$  in table VADC 5V.

**Electrical Specification 5 V / 3.3 V switchable Pads**

5) Values for Pull-down resistor is defined via parameter  $R_{MDD}$  in table VADC 5V.

**Table 3-12 RFast 3.3V pad**

Parameter	Symbol	Values			Unit	Note / Test Condition
		Min.	Typ.	Max.		
On-Resistance of pad output	$R_{DSON}$ CC	8	20	30	Ohm	Driver = RGMII; $I_{OH/OL} = 8mA$
		125	225	320	Ohm	medium driver; $I_{OH/OL} = 2mA$
		31	55	80	Ohm	strong driver; $I_{OH/OL} = 8mA$
Input Duty Cycle	$f_D$ SR	47.5	50	52.5		
Rise / Fall time <sup>1) 2)</sup>	$t_{RF}$ CC	1.6	-	4.5	ns	$C_L = 25pF$ ; driver = strong sharp edge; from $0.2 * V_{FLEX}$ to $0.8 * V_{FLEX}$
		-	-	5	ns	$C_L = 25pF$ ; driver = strong sharp edge; from 0.8V to 2.0V (RMII)
		-	-	1	ns	Driver = RGMII; from 20%V to 80%V; $C_L = 15pF$
		$2+0.57*C_L$	$5.5+0.75*C_L$	$10+1.25*C_L$	ns	driver = medium; $C_L \leq 200pF$
		$1.5+0.18*C_L$	$1.5+0.28*C_L$	$8+0.4*C_L$	ns	driver = strong edge = medium; $C_L \leq 200pF$
		$0.75+0.08*C_L$	$0.75+0.11*C_L$	$2.5+0.21*C_L$	ns	driver = strong edge = sharp ; $C_L \leq 200pF$
		-0.4	-	0.4	ns	valid for all data rates excluding clock tolerance
Asymmetry of sending	$t_{TX\_ASYM}$ CC	-0.4	-	0.4	ns	valid for all data rates excluding clock tolerance
Input frequency	$f_{IN}$ CC	-	-	160	MHz	

**Electrical Specification 5 V / 3.3 V switchable Pads**
**Table 3-12 RFast 3.3V pad (cont'd)**

Parameter	Symbol	Values			Unit	Note / Test Condition
		Min.	Typ.	Max.		
Input hysteresis <sup>3)</sup>	$HYS_{CC}$	0.055 * $V_{FLEX}$	-	-	V	non of the neighbor pads are used as output; AL
		0.09 * $V_{FLEX}$	-	-	V	non of the neighbor pads are used as output; TTL
		0.055 * $V_{FLEX}$	-	-	V	non of the neighbor pads are used as output;TTL (degraded, used for CIF)
		125	-	-	mV	two of the neighbor pads are used as output with driver=strong and edge=sharp; AL
Pull-up current <sup>4)</sup>	$I_{PUH_{CC}}$	17	-	-	$\mu A$	$V_{IH}$ ; AL and TTL (degraded, used for CIF)
		11	-	-	$\mu A$	$V_{IH}$ ; TTL
		-	-	80	$\mu A$	$V_{IL}$ ; AL and TTL and TTL (degraded, used for CIF)
Pull-down current <sup>5)</sup>	$I_{PDL_{CC}}$	-	-	105	$\mu A$	$V_{IH}$ ; AL and TTL (degraded, used for CIF)
		-	-	115	$\mu A$	$V_{IH}$ ; TTL
		19	-	-	$\mu A$	$V_{IL}$ ; AL and TTL
		15	-	-	$\mu A$	$V_{IL}$ ; TTL (degraded, used for CIF)
Input leakage current	$I_{OZ_{CC}}$	-1700	-	1700	nA	$T_J \leq 150^\circ C$ ; (0.1 * $V_{FLEX}$ ) < $V_{IN}$ < (0.9 * $V_{FLEX}$ )
		-2100	-	2100	nA	$T_J \leq 150^\circ C$ ; else
		-3000	-	3000	nA	$T_J \leq 170^\circ C$ ; (0.1 * $V_{FLEX}$ ) < $V_{IN}$ < (0.9 * $V_{FLEX}$ )
		-4000	-	4000	nA	$T_J \leq 170^\circ C$ ; else
Input high voltage level	$V_{IH_{SR}}$	0.7 * $V_{FLEX}$	-	-	V	AL
		2.0	-	-	V	TTL
		1.4	-	-	V	TTL (degraded, used for CIF)

**Electrical Specification 5 V / 3.3 V switchable Pads**
**Table 3-12 RFast 3.3V pad (cont'd)**

Parameter	Symbol	Values			Unit	Note / Test Condition
		Min.	Typ.	Max.		
Input low voltage level	$V_{IL}$ SR	-	-	0.42 * $V_{FLEX}$	V	AL
		-	-	0.8	V	TTL
		-	-	0.5	V	TTL (degraded, used for CIF)
Input low threshold variation	$V_{ILD}$ SR	-33	-	33	mV	max. variation of 1ms; $V_{FLEX}$ = constant; AL
Pin capacitance	$C_{IO}$ CC	-	2	3.5	pF	in addition 2.5pF from package to be added
Pad set-up time to get an software update of the configuration active	$t_{SET}$ CC	-	-	100	ns	

- 1) In the formulas the value of  $C_L$  needs to be entered in pF to obtain results in ns.
- 2) Rise / fall times are defined 10% - 90% of pad supply voltage.
- 3) Hysteresis is implemented to avoid metastable states and switching due to internal ground bounce. It can't be guaranteed that it suppresses switching due to external system noise.
- 4) Values for Pull-up resistor is defined via parameter  $R_{MDU}$  in table VADC 5V.
- 5) Values for Pull-down resistor is defined via parameter  $R_{MDD}$  in table VADC 5V.

**Table 3-13 Class S 5V**

Parameter	Symbol	Values			Unit	Note / Test Condition
		Min.	Typ.	Max.		
Input frequency	$f_{IN}$ CC	-	-	160	MHz	
Input hysteresis <sup>1)</sup>	$HYS$ CC	0.09 * $V_{DDM}$	-	-	V	non of the neighbor pads are used as output; AL
		0.075 * $V_{DDM}$	-	-	V	non of the neighbor pads are used as output; TTL
		75	-	-	mV	two of the neighbor pads are used as output with driver=strong and edge=sharp; AL
Pull-up current <sup>2)</sup>	$I_{PUH}$ CC	30	-	-	μA	$V_{IH}$ ; AL or TTL
		-	-	130	μA	$V_{IL}$ ; AL or TTL
Pull-down current <sup>3)</sup>	$I_{PDL}$ CC	-	-	130	μA	$V_{IH}$ ; AL or TTL
		30	-	-	μA	$V_{IL}$ ; AL
		28	-	-	μA	$V_{IL}$ ; TTL

**Electrical Specification 5 V / 3.3 V switchable Pads**
**Table 3-13 Class S 5V (cont'd)**

Parameter	Symbol	Values			Unit	Note / Test Condition
		Min.	Typ.	Max.		
Input leakage current	$I_{OZ}$ CC	-150	-	150	nA	$T_J \leq 150^\circ\text{C}$ ; else
		-300	-	300	nA	$T_J \leq 150^\circ\text{C}$ ; PDD option available, or AltRef option available and EDSADC channel connected, or two EDSADC channels connected
		-300	-	300	nA	$T_J \leq 170^\circ\text{C}$ ; else
		-600	-	600	nA	$T_J \leq 170^\circ\text{C}$ ; PDD option available, or AltRef option available and EDSADC channel connected, or two EDSADC channels connected
Input high voltage level	$V_{IH}$ SR	$0.7 * V_{DDM}$	-	-	V	AL
		2.0	-	-	V	TTL
Input low voltage level	$V_{IL}$ SR	-	-	$0.44 * V_{DDM}$	V	AL
		-	-	0.8	V	TTL
Input low threshold variation	$V_{ILD}$ SR	-50	-	50	mV	max. variation of 1ms; $V_{DDM} = \text{constant}$ ; AL
Pin capacitance	$C_{IO}$ CC	-	2	3	pF	in addition 2.5pF from package to be added
Pad set-up time to get an software update of the configuration active	$t_{SET}$ CC	-	-	100	ns	

- 1) Hysteresis is implemented to avoid metastable states and switching due to internal ground bounce. It can't be guaranteed that it suppresses switching due to external system noise.
- 2) Values for Pull-up resistor is defined via parameter  $R_{MDU}$  in table VADC 5V.
- 3) Values for Pull-down resistor is defined via parameter  $R_{MDD}$  in table VADC 5V.

**Table 3-14 Class S 3.3V**

Parameter	Symbol	Values			Unit	Note / Test Condition
		Min.	Typ.	Max.		
Input frequency	$f_{IN}$ CC	-	-	160	MHz	

**Electrical Specification 5 V / 3.3 V switchable Pads**
**Table 3-14 Class S 3.3V (cont'd)**

Parameter	Symbol	Values			Unit	Note / Test Condition
		Min.	Typ.	Max.		
Input hysteresis <sup>1)</sup>	$HYS_{CC}$	0.055 * $V_{DDM}$	-	-	V	non of the neighbor pads are used as output; AL
		0.09 * $V_{DDM}$	-	-	V	non of the neighbor pads are used as output; TTL
		0.065 * $V_{DDM}$	-	-	V	non of the neighbor pads are used as output; TTL (degraded used for CIF)
		125	-	-	mV	two of the neighbor pads are used as output with driver=strong and edge=sharp; AL
Pull-up current <sup>2)</sup>	$I_{PUH_{CC}}$	17	-	-	$\mu A$	$V_{IH}$ ; AL and TTL (degraded, used for CIF)
		11	-	-	$\mu A$	$V_{IH}$ ; TTL
		-	-	80	$\mu A$	$V_{IL}$
Pull-down current <sup>3)</sup>	$I_{PDL_{CC}}$	-	-	105	$\mu A$	$V_{IH}$ ; AL and TTL (degraded, used for CIF)
		-	-	115	$\mu A$	$V_{IH}$ ; TTL
		19	-	-	$\mu A$	$V_{IL}$ ; AL and TTL
		15	-	-	$\mu A$	$V_{IL}$ ; TTL (degraded, used for CIF)
Input leakage current	$I_{OZ_{CC}}$	-150	-	150	nA	$T_J \leq 150^\circ C$ ; else
		-300	-	300	nA	$T_J \leq 150^\circ C$ ; PDD option available, or AltRef option available and EDSADC channel connected
		-300	-	300	nA	$T_J \leq 170^\circ C$ ; else
		-600	-	600	nA	$T_J \leq 170^\circ C$ ; PDD option available
Input high voltage level	$V_{IH_{SR}}$	0.7 * $V_{DDM}$	-	-	V	AL
		2.0	-	-	V	TTL
		1.4	-	-	V	TTL (degraded, used for CIF)

**Electrical Specification 5 V / 3.3 V switchable Pads**
**Table 3-14 Class S 3.3V (cont'd)**

Parameter	Symbol	Values			Unit	Note / Test Condition
		Min.	Typ.	Max.		
Input low voltage level	$V_{IL}$ SR	-	-	0.42 * $V_{DDM}$	V	AL
		-	-	0.8	V	TTL
		-	-	0.5	V	TTL (degraded, used for CIF)
Input low threshold variation	$V_{ILD}$ SR	-33	-	33	mV	max. variation of 1ms; $V_{DDM}$ = constant; AL
Pin capacitance	$C_{IO}$ CC	-	2	3	pF	in addition 2.5pF from package to be added
Pad set-up time to get an software update of the configuration active	$t_{SET}$ CC	-	-	100	ns	

- 1) Hysteresis is implemented to avoid metastable states and switching due to internal ground bounce. It can't be guaranteed that it suppresses switching due to external system noise.
- 2) Values for Pull-up resistor is defined via parameter  $R_{MDU}$  in table VADC 5V.
- 3) Values for Pull-down resistor is defined via parameter  $R_{MDD}$  in table VADC 5V.

**Table 3-15 Class D**

Parameter	Symbol	Values			Unit	Note / Test Condition
		Min.	Typ.	Max.		
Input leakage current	$I_{OZ}$ CC	-150	-	150	nA	$T_J \leq 150^\circ\text{C}$ ; else
		-300 <sup>1)</sup>	-	300 <sup>1)</sup>	nA	$T_J \leq 150^\circ\text{C}$ ; PDD option available, or AltRef option available and EDSADC channel connected, or two EDSADC channels connected
		-300	-	300	nA	$T_J \leq 170^\circ\text{C}$ ; else
		-600 <sup>2)</sup>	-	600 <sup>2)</sup>	nA	$T_J \leq 170^\circ\text{C}$ ; PDD option available, or AltRef option available and EDSADC channel connected, or two EDSADC channels connected
Pin capacitance	$C_{IO}$ CC	-	2	3	pF	in addition 2.5pF from package to be added

- 1) For AN11 100 nA need to be added.
- 2) For AN11 200 nA need to be added.

**Electrical Specification 5 V / 3.3 V switchable Pads**
**Table 3-16 ADC Reference Pads**

Parameter	Symbol	Values			Unit	Note / Test Condition
		Min.	Typ.	Max.		
Input leakage current for $V_{AREF}$	$I_{OZ2}$ CC	-2 <sup>1)</sup>	-	2 <sup>1)</sup>	$\mu\text{A}$	$T_J \leq 150^\circ\text{C}$ ; $V_{AREF} < V_{DDM}$ ; for EVADC; valid for BGA292
		-7 <sup>1)</sup>	-	7 <sup>1)</sup>	$\mu\text{A}$	$T_J \leq 150^\circ\text{C}$ ; $V_{AREF} \leq V_{DDM} + 50\text{mV}$ ; for EVADC; valid for BGA292
		-4 <sup>1)</sup>	-	4 <sup>1)</sup>	$\mu\text{A}$	$T_J \leq 170^\circ\text{C}$ ; $V_{AREF} < V_{DDM}$ ; for EVADC; valid for BGA292
		-14 <sup>1)</sup>	-	14 <sup>1)</sup>	$\mu\text{A}$	$T_J \leq 170^\circ\text{C}$ ; $V_{AREF} \leq V_{DDM} + 50\text{mV}$ ; for EVADC; valid for BGA292
		-1 <sup>2)</sup>	-	1 <sup>2)</sup>	$\mu\text{A}$	$T_J \leq 150^\circ\text{C}$ ; $V_{AREF} < V_{DDM}$ ; for EVADC; valid for BGA516
		-2 <sup>2)</sup>	-	2 <sup>2)</sup>	$\mu\text{A}$	$T_J \leq 170^\circ\text{C}$ ; $V_{AREF} < V_{DDM}$ ; for EVADC; valid for BGA516
		-3.5 <sup>2)</sup>	-	3.5 <sup>2)</sup>	$\mu\text{A}$	$T_J \leq 150^\circ\text{C}$ ; $V_{AREF} \leq V_{DDM} + 50\text{mV}$ ; for EVADC; valid for BGA516
		-7 <sup>2)</sup>	-	7 <sup>2)</sup>	$\mu\text{A}$	$T_J \leq 170^\circ\text{C}$ ; $V_{AREF} \leq V_{DDM} + 50\text{mV}$ ; for EVADC; valid for BGA516
		-2 <sup>3)</sup>	-	2 <sup>3)</sup>	$\mu\text{A}$	$T_J \leq 150^\circ\text{C}$ ; $V_{AREF} < V_{DDM}$ ; for EDSADC
		-4 <sup>3)</sup>	-	4 <sup>3)</sup>	$\mu\text{A}$	$T_J \leq 170^\circ\text{C}$ ; $V_{AREF} < V_{DDM}$ ; for EDSADC
		-6 <sup>3)</sup>	-	6 <sup>3)</sup>	$\mu\text{A}$	$T_J \leq 150^\circ\text{C}$ ; $V_{AREF} \leq V_{DDM} + 50\text{mV}$ ; for EDSADC
		-12 <sup>3)</sup>	-	12 <sup>3)</sup>	$\mu\text{A}$	$T_J \leq 170^\circ\text{C}$ ; $V_{AREF} \leq V_{DDM} + 50\text{mV}$ ; for EDSADC

1) Limit is valid for VAREF2 pin.

2) Limit is valid for VAREF2 and VAREF3 pins each.

3) Limit is valid for VAREF1 pin.

**Table 3-17 Driver Mode Selection for Slow Pads**

PDx.2	PDx.1	PDx.0	Port Functionality	Driver Setting
X	X	0	Speed grade 1	medium sharp edge (sm)
X	X	1	Speed grade 2	medium medium edge (m)

**Table 3-18 Driver Mode Selection for Fast Pads**

PDx.2	PDx.1	PDx.0	Port Functionality	Driver Setting
X	0	0	Speed grade 1	Strong sharp edge (ss)
X	0	1	Speed grade 2	Strong medium edge (sm)
X	1	0	Speed grade 3	medium (m)
X	1	1	Speed grade 4	Reserved, do not use this combination

**Table 3-19 Driver Mode Selection for RFast Pads**

PDx.2	PDx.1	PDx.0	Port Functionality	Driver Setting
X	0	0	Speed grade 1	Strong sharp edge (ss)
X	0	1	Speed grade 2	Strong medium edge (sm)
X	1	0	Speed grade 3	medium (m)
X	1	1	Speed grade 4	RGMII function active

### 3.6 High performance LVDS Pads

This LVDS pad type is used for the high speed chip to chip communication interface of the new TC38x. It compose out of a LVDS pad and a fast pad.

$C_L = 2.5$  pF for all LVDS parameters.

**Table 3-20 LVDS - IEEE standard LVDS general purpose link (GPL)**

Parameter	Symbol	Values			Unit	Note / Test Condition
		Min.	Typ.	Max.		
Output impedance	$R_0$ CC	40	-	140	Ohm	$V_{cm} = 1.0$ V and 1.4 V
Rise time (20% - 80%)	$t_{rise20}$ CC	-	-	0.75 <sup>1)</sup>	ns	$Z_L = 100$ Ohm $\pm 20\%$ @2pF external load
Fall time (20% - 80%)	$t_{fall20}$ CC	-	-	0.75 <sup>2)</sup>	ns	$Z_L = 100$ Ohm $\pm 20\%$ @2pF external load
Output differential voltage <sup>3)</sup>	$V_{OD}$ CC	240	-	330	mV	$R_T = 100$ Ohm $\pm 1\%$ ; LPCRx.VDIFFADJ=00
		280	-	370	mV	$R_T = 100$ Ohm $\pm 1\%$ ; LPCRx.VDIFFADJ=01
		320	-	410	mV	$R_T = 100$ Ohm $\pm 1\%$ ; LPCRx.VDIFFADJ=10
		380	-	500	mV	$R_T = 100$ Ohm $\pm 1\%$ ; LPCRx.VDIFFADJ=11; Multi slave operation
Output voltage high	$V_{OH}$ CC	-	-	1475	mV	$R_T = 100$ Ohm $\pm 1\%$ VDIFFADJ=00 and 01
		-	-	1500	mV	$R_T = 100$ Ohm $\pm 1\%$ VDIFFADJ=10 and 11
Output voltage low	$V_{OL}$ CC	925	-	-	mV	$R_T = 100$ Ohm $\pm 1\%$ VDIFFADJ=00 and 01
		900	-	-	mV	$R_T = 100$ Ohm $\pm 1\%$ VDIFFADJ=10 and 11
Output offset (Common mode) voltage	$V_{OS}$ CC	1125	-	1275	mV	$R_T = 100$ Ohm $\pm 1\%$
Input voltage range	$V_I$ SR	0	-	1600	mV	Driver ground potential difference < 925 mV; $R_T = 100$ Ohm $\pm 10\%$
		0	-	2400	mV	Driver ground potential difference < 925 mV; $R_T = 100$ Ohm $\pm 20\%$
Input differential threshold	$V_{idth}$ SR	-100	-	100	mV	Driver ground potential difference < 900 mV; VDIFFADJ=10 and 11
		-100	-	100	mV	Driver ground potential difference < 925 mV; VDIFFADJ=00 and 01

## Electrical Specification High performance LVDS Pads

Table 3-20 LVDS - IEEE standard LVDS general purpose link (GPL) (cont'd)

Parameter	Symbol	Values			Unit	Note / Test Condition
		Min.	Typ.	Max.		
Receiver differential input impedance	$R_{in}$ CC	80	-	120	Ohm	$V_I \leq 2400$ mV
Output differential voltage Sleep Mode <sup>4)</sup>	$V_{ODSM}$ CC	-5	-	20	mV	$R_T = 100$ Ohm $\pm 20\%$ ; LPCRx.VDIFFADJ=xx
Delta output impedance	$dR0$ SR	-	-	10	%	$V_{cm} = 1.0$ V and 1.4 V
Change in VOS between 0 and 1	$dVOS$ CC	-	-	25	mV	$R_T = 100$ Ohm $\pm 1\%$
Change in Vod between 0 and 1	$dVod$ CC	-	-	25	mV	$R_T = 100$ Ohm $\pm 1\%$
Pad set-up time	$t_{SET\_LVDS}$ CC	-	10	13	$\mu$ s	
Duty cycle	$t_{duty}$ CC	45	-	55	%	

1)  $t_{rise20} = 0.75ns + (C_L - 2)[pF]*20ps$ .  $C_L$  defines the external load.

2)  $t_{fall20} = 0.75ns + (C_L - 2)[pF]*20ps$ .  $C_L$  defines the external load.

3) Potential violations of the IEEE Std 1596.3 are intended for the new multislave support feature. To be compliant to IEEE Std 1596.3 LPCRx.VDIFFADJ has to be configured to 01.

4) Common Mode voltage of Tx is maintained.

*Note: Driver ground potential difference is defined as driver-receiver potential difference, that can result in a voltage shift when comparing driver output voltage level and receiver input voltage level of a transmitted signal.*

*Note:  $R_T$  in table 'LVDS - IEEE standard LVDS general purpose Link (GPL)' is as termination resistor of the receiver according to figure 3-5 in IEEE Std 1596.3-1996 and is represent in [Figure 3-1](#) either by  $R_{in}$  or by  $R_T=100Ohm$  but not both. If  $R_T$  is mentioned in column Note / Test Condition always the internal resistor  $R_{in}$  in [Figure 3-1](#) is the selected one.*

default after start-up = CMOS function

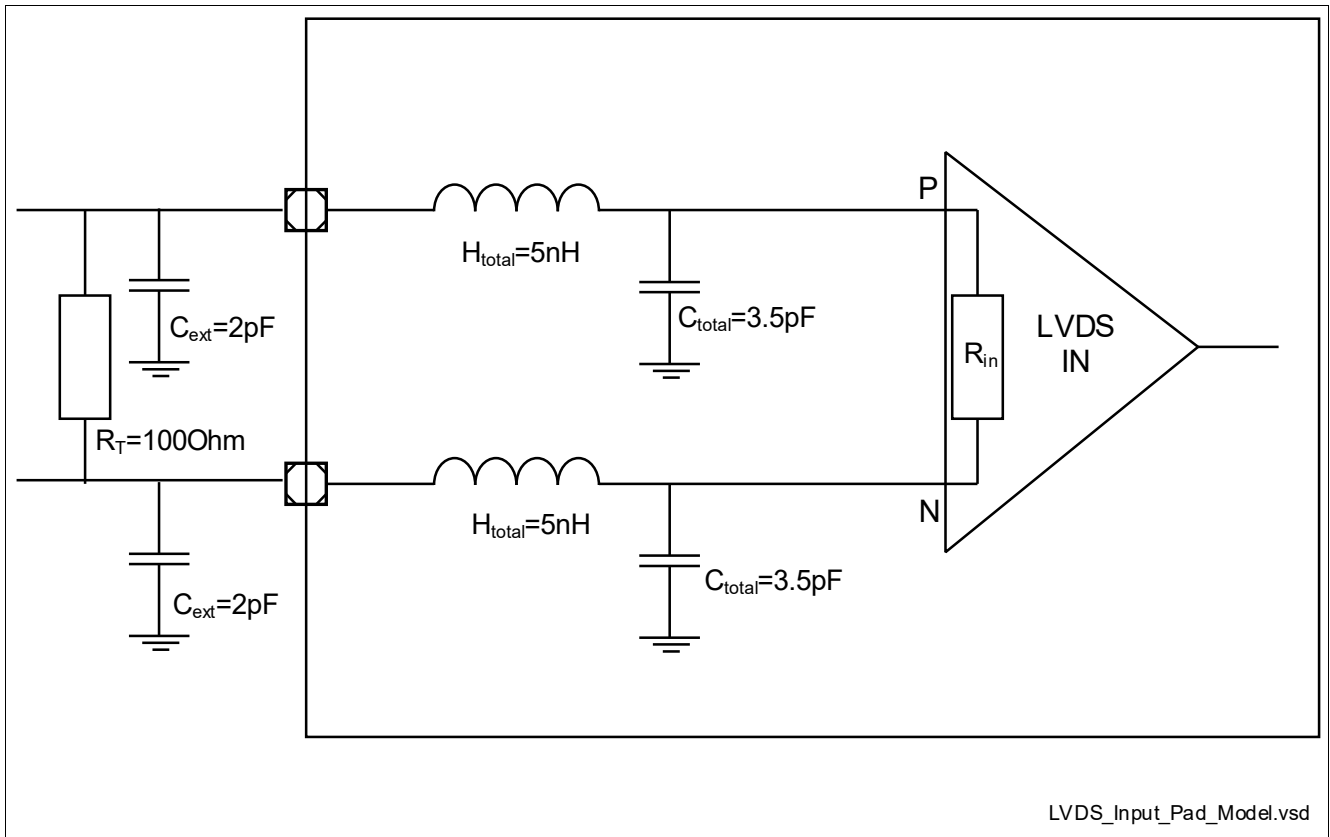

Figure 3-1 LVDS pad Input model

### 3.7 VADC Parameters

The accuracy of the converter results depends on the reference voltage range. The parameters in the table below are valid for a reference voltage range of  $(V_{AREF} - V_{AGND}) \geq 4.5 \text{ V}$ . If the reference voltage range is below 4.5 V by a factor of  $k$  (e.g. 3.3 V), the accuracy parameters increase by a factor of  $1.1/k$  (e.g.  $1.1 \times 4.5 / 3.3 = 1.5$ ).

Noise on supply voltage  $V_{DDM}$  influences the conversion. The accuracy (error) parameters are defined for a supply voltage ripple of below 20 mVpp up to 10 MHz (below 5 mVpp above 10 MHz).

Digital functions overlapping analog inputs influence accuracy.

The total unadjusted error (TUE) is defined without noise. The overall deviation depends on TUE and  $EN_{RMS}$  (depending on the noise distribution). Example: For a noise distribution of 4 sigma and  $EN_{RMS} = 1.0$  the additional peak-peak noise error is  $\pm(4 \times 1.0) = 8 \text{ LSB}_{12}$ .

Fast compare operations are executed with 10-bit values.

The noise reduction feature improves the result by adding additional conversion steps. The conversion times, therefore, increase accordingly ( $4 \times t_{ADCI} + 3 \times t_{ADC}$  for each of 1, 3, or 7 steps).

**Table 3-21 VADC 5V**

Parameter	Symbol	Values			Unit	Note / Test Condition
		Min.	Typ.	Max.		
EVADC IVR output voltage	$V_{DDK}$ CC	1.15	-	1.35	V	Measured at low temperature.
Deviation of IVR output voltage $V_{DDK}$	$dV_{DDK}$ CC	-2	-	2	%	Based on device-specific value
Analog reference voltage <sup>1)</sup>	$V_{AREF}$ SR	4.5	5.0	$V_{DDM} + 0.05$	V	$4.5 \text{ V} \leq V_{DDM} \leq 5.5 \text{ V}$
		2.97	3.3	$V_{DDM} + 0.05$	V	$2.97 \text{ V} \leq V_{DDM} < 4.5 \text{ V}$
Analog reference ground	$V_{AGND}$ SR	$V_{SSM}$	$V_{SSM}$	$V_{SSM}$	V	$V_{SSM}$ and $V_{AGND}$ are connected together
Analog input voltage range	$V_{AIN}$ SR	$V_{AGND}$	-	$V_{AREF}$	V	$V_{AIN}$ is limited by the respective pad supply voltage; see pin configuration (buffer type)
Converter reference clock	$f_{ADCI}$ SR	16	40	53.33	MHz	$4.5 \text{ V} \leq V_{DDM} \leq 5.5 \text{ V}$
		16	20	26.67	MHz	$2.97 \text{ V} \leq V_{DDM} < 4.5 \text{ V}$
Total Unadjusted Error <sup>2) 3)</sup>	$TUE$ CC	-4	-	4	LSB	12-bit resolution for primary/secondary groups, 10-bit resolution for fast compare channels
INL Error <sup>2)</sup>	$EA_{INL}$ CC	-3	-	3	LSB	
DNL error <sup>2)4)</sup>	$EA_{DNL}$ CC	-1	-	3	LSB	
Gain Error <sup>2)</sup>	$EA_{GAIN}$ CC	-3.5	-	3.5	LSB	
Offset Error <sup>2)3)</sup>	$EA_{OFF}$ CC	-4	-	4	LSB	

**Electrical Specification VADC Parameters**
**Table 3-21 VADC 5V (cont'd)**

Parameter	Symbol	Values			Unit	Note / Test Condition
		Min.	Typ.	Max.		
RMS Noise <sup>2)5) 6)</sup>	$EN_{RMS}$ CC	-	0.5	0.8	LSB	Noise reduction level 3
		-	0.5	1.0	LSB	Standard conversion
Reference input charge consumption per conversion (from $V_{AREF}$ ) <sup>7) 8) 9)</sup>	$Q_{CONV}$ CC	-	-	20	pC	$V_{AIN} = 0$ V (worst case), precharging disabled
		-	-	10	pC	$V_{AIN} = 0$ V (worst case), precharging enabled, $V_{DDM} - 5\% < V_{AREF} < V_{DDM} + 50$ mV
Switched capacitance of an analog input	$C_{AINS}$ CC	-	2.5	3.4	pF	Input buffer disabled
Analog input charge consumption <sup>10)</sup>	$Q_{AINS}$ CC	-	-	3.5	pC	Primary groups and fast compare channels; $V_{AIN} = V_{AREF}$ ; $V_{DDM} = 5.0$ V; input buffer enabled; $T_J \leq 150^\circ\text{C}$
		-	-	3.8	pC	Primary groups and fast compare channels; $V_{AIN} = V_{AREF}$ ; $V_{DDM} = 5.0$ V; input buffer enabled; $T_J > 150^\circ\text{C}$
		-	-	4.4	pC	Secondary groups; $V_{AIN} = V_{AREF}$ ; $V_{DDM} = 5.0$ V; input buffer enabled; $T_J \leq 150^\circ\text{C}$
		-	-	4.8	pC	Secondary groups; $V_{AIN} = V_{AREF}$ ; $V_{DDM} = 5.0$ V; input buffer enabled; $T_J > 150^\circ\text{C}$

**Electrical Specification VADC Parameters**
**Table 3-21 VADC 5V (cont'd)**

Parameter	Symbol	Values			Unit	Note / Test Condition
		Min.	Typ.	Max.		
Sampling time	$t_S$ SR	100	-	-	ns	Primary group or fast compare channel, 4.5 V $\leq V_{DDM} \leq 5.5$ V; input buffer disabled
		300	-	-	ns	Primary group or fast compare channel, 4.5 V $\leq V_{DDM} \leq 5.5$ V; input buffer enabled
		500	-	-	ns	Secondary group, 4.5 V $\leq V_{DDM} \leq 5.5$ V; input buffer disabled
		700	-	-	ns	Secondary group, 4.5 V $\leq V_{DDM} \leq 5.5$ V; input buffer enabled
		200	-	-	ns	Primary Group or fast compare channel, 2.97 V $\leq V_{DDM} < 4.5$ V; input buffer disabled
		400	-	-	ns	Primary group or fast compare channel, 2.97 V $\leq V_{DDM} < 4.5$ V; input buffer enabled
		1000	-	-	ns	Secondary group, 2.97 V $\leq V_{DDM} < 4.5$ V; input buffer disabled
		1200	-	-	ns	Secondary group, 2.97 V $\leq V_{DDM} < 4.5$ V; input buffer enabled
Sampling time for calibration	$t_{SCAL}$ SR	50	-	-	ns	4.5 V $\leq V_{DDM} \leq 5.5$ V
		100	-	-	ns	2.97 V $\leq V_{DDM} < 4.5$ V
Input buffer switch-on time	$t_{BUF}$ CC	-	0.4	1	$\mu$ s	
Wakeup time	$t_{WU}$ CC	-	0.1	0.2	$\mu$ s	Fast standby mode
		-	1.6	3	$\mu$ s	Slow standby mode
Broken wire detection delay against $V_{AREF}$	$t_{BWR}$ CC	-	100	-	cycles	Result above 80% of full scale range, analog input buffer disabled
Broken wire detection delay against $V_{AGND}$	$t_{BWG}$ CC	-	100	-	cycles	Result below 10% of full scale range, analog input buffer disabled
Converter diagnostics unit resistance <sup>11)</sup>	$R_{CSD}$ CC	45	-	75	kOhm	
Converter diagnostics voltage accuracy	$dV_{CSD}$ CC	-10	-	10	%	Percentage refers to $V_{DDM}$

Electrical Specification VADC Parameters

Table 3-21 VADC 5V (cont'd)

Parameter	Symbol	Values			Unit	Note / Test Condition
		Min.	Typ.	Max.		
Resistance of the multiplexer diagnostics pull-up device	$R_{MDU\ CC}$	30	-	42	kOhm	$0\text{ V} \leq V_{IN} \leq 0.9 \cdot V_{DDM}$ , Automotive Levels
		56	-	78	kOhm	$0\text{ V} \leq V_{IN} \leq 0.9 \cdot V_{DDM}$ , TTL Levels
Resistance of the multiplexer diagnostics pull-down device	$R_{MDD\ CC}$	43	-	58	kOhm	$0.1 \cdot V_{DDM} \leq V_{IN} \leq V_{DDM}$ , Automotive level
		18	-	25	kOhm	$0.1 \cdot V_{DDM} \leq V_{IN} \leq V_{DDM}$ , TTL level
Resistance of the pull-down test device	$R_{PDD\ CC}$	-	-	0.3	kOhm	Measured at pad input voltage $V_{IN} = V_{DDM} / 2$ .

- 1) These limits apply to the standard reference input as well as to the alternate reference input.
- 2) Parameter depends on reference voltage range and supply ripple, see introduction. Resulting worst case combined error is arithmetic combination of TUE and  $EN_{RMS}$ . Tests are done with postcalibration disabled, after completing the startup calibration.
- 3) Analog inputs mapped to pads of the type SLOW influence accuracy. The values for this parameter increase by 3  $LSB_{12}$ .
- 4) Monotonic characteristic, no missing codes when calibrated.
- 5) Parameter  $EN_{RMS}$  refers to a 1 sigma distribution.
- 6) Analog inputs mapped to pads of the type SLOW the RMS noise ( $EN_{RMS}$ ) can be up to 2  $LSB_{12}$  (soft switching for DC/DC enabled).
- 7) For reduced reference voltages  $V_{AREF} < 3.375\text{V}$ , the consumed charge  $Q_{CONV}$  is reduced by the factor of  $k_2 = V_{AREF} [V] / 3.375$ . For reduced reference voltages  $4.5\text{V} < V_{AREF} \leq 3.375\text{V}$ ,  $Q_{CONV}$  is not reduced.
- 8) Maximum charge increases by 15 pC when BWD (Broken Wire Detection) is active.
- 9) Fast compare channels only consume 1/3 of the charge for a primary/secondary group.
- 10) For analog inputs with overlaid digital GPIOs or with PDD function this value increases by 1 pC.
- 11) Use a sample time of at least 1.1  $\mu\text{s}$  to enable proper settling of the test voltage.

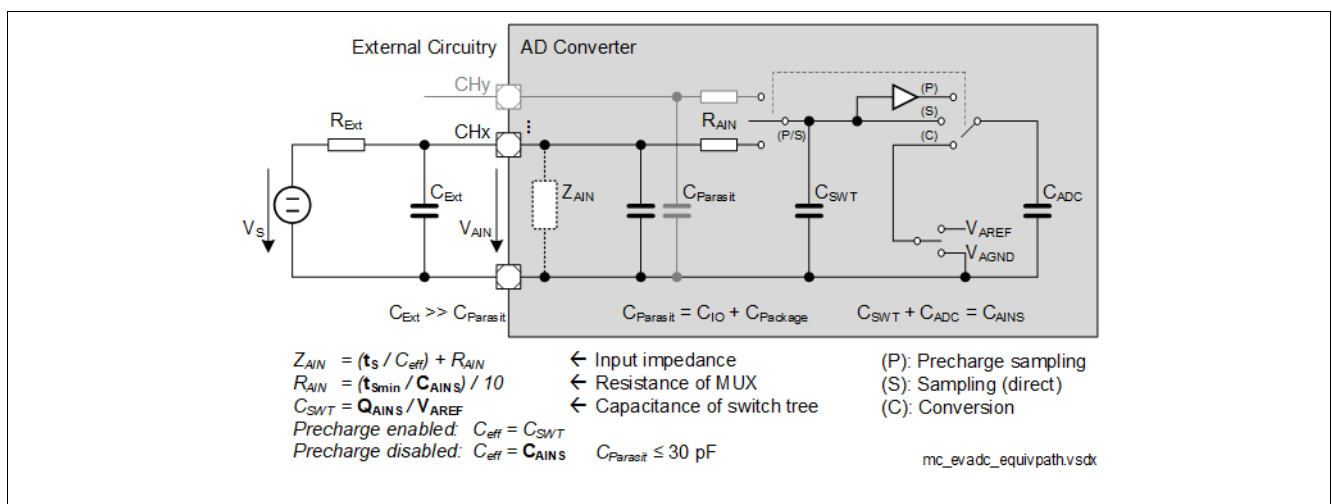

Figure 3-2 Equivalent Circuitry for Analog Inputs

### 3.8 DSADC Parameters

The DSADC parameters are valid only for voltage range  $4.5\text{ V} \leq V_{\text{DDM}} \leq 5.5\text{ V}$ .

These parameters describe the product properties and do not include external circuitry. The values are valid for junction temperatures  $T_j \leq 150^\circ\text{C}$  if not defined explicitly.

Calibration is specified for gain factors 1 and 2, calibrated values refer to these settings.

The signal-noise ratio (SNR) is specified for differential inputs. For single ended operation the resulting signal-noise ratio is reduced by 6 dB. For quasi-differential mode (i.e. using  $V_{\text{CM}}$ ) it is reduced by 6 dB for gain = 1 and by 3 dB for gain= 2.

**Table 3-22 DSADC 5V**

Parameter	Symbol	Values			Unit	Note / Test Condition
		Min.	Typ.	Max.		
Common mode voltage bias resistance	$R_{\text{BIAS}}$ CC	105	130	155	kOhm	On-chip variation $\leq \pm 2.5\%$ .
Positive reference voltage	$V_{\text{AREF}}$ SR	4.5	-	$V_{\text{DDM}} + 0.05$	V	
Reference ground voltage	$V_{\text{AGND}}$ SR	$V_{\text{SSM}}$	-	$V_{\text{SSM}}$	V	$V_{\text{SSM}}$ and $V_{\text{AGND}}$ are connected together
Reference load current	$I_{\text{REF}}$ CC	-	10	12	$\mu\text{A}$	Per modulator
		-	-	14	$\mu\text{A}$	Per modulator, $T_j > 150^\circ\text{C}$
Common mode voltage accuracy <sup>1)</sup>	$dV_{\text{CM}}$ CC	-100	-	100	mV	Deviation from selected voltage
Analog input voltage range	$V_{\text{DSIN}}$ SR	$V_{\text{SSM}}$	-	$2 * V_{\text{DDM}}$	V	Differential; $V_{\text{DSXP}} - V_{\text{DSXN}}$
		$V_{\text{SSM}}$	-	$V_{\text{DDM}}$	V	Single ended
Input current <sup>2)</sup>	$I_{\text{RMS}}$ CC	7	10	13	$\mu\text{A}$	Exact value ( $\pm 1\%$ ) available in UCB; valid for gain = 1 and $f_{\text{MOD}} = 26.7\text{ MHz}$
On-chip modulator clock frequency	$f_{\text{MOD}}$ SR	16	-	40	MHz	
Gain error <sup>3) 4)</sup>	$ED_{\text{GAIN}}$ CC	-0.2 <sup>5)</sup>	$\pm 0.1$ <sup>5)</sup>	0.2 <sup>5)</sup>	%	$T_j \leq 150^\circ\text{C}$ ; Target, calibrated, $V_{\text{AREF}}$ constant after calibration; $f_{\text{MOD}} = 26.67\text{ MHz}$
		-	$\pm 0.25$	-	%	$T_j > 150^\circ\text{C}$ ; $V_{\text{AREF}}$ constant after calibration; $f_{\text{MOD}} = 26.67\text{ MHz}$
		-1	-	1	%	Calibrated once; $f_{\text{MOD}} = 26.67\text{ MHz}$
		-2.5	-	2.5	%	Uncalibrated; $f_{\text{MOD}} = 26.67\text{ MHz}$

**Electrical Specification DSADC Parameters**
**Table 3-22 DSADC 5V (cont'd)**

Parameter	Symbol	Values			Unit	Note / Test Condition
		Min.	Typ.	Max.		
DC offset error <sup>3)</sup>	$ED_{OFF}$ CC	-5 <sup>5)</sup>	-	5 <sup>5)</sup>	mV	Calibrated; $f_{MOD} = 26.67$ MHz
		-10	-	10	mV	Calibrated once; $f_{MOD} = 26.67$ MHz
		-30	-	30	mV	Uncalibrated; $f_{MOD} = 26.67$ MHz
Signal-Noise Ratio for differential input signals <sup>2),6) 7)</sup>	SNR CC	80	-	-	dB	$T_J \leq 150^\circ\text{C}$ ; $f_{PB} = 30$ kHz; $f_{MOD} = 26.67$ MHz
		78	-	-	dB	$T_J \leq 150^\circ\text{C}$ ; $f_{PB} = 50$ kHz; $f_{MOD} = 26.67$ MHz
		74	-	-	dB	$T_J \leq 150^\circ\text{C}$ ; $f_{PB} = 100$ kHz; $f_{MOD} = 26.67$ MHz
Signal-Noise Ratio degradation	DSNR CC	-	-	3	dB	$T_J > 150^\circ\text{C}$ ; Resulting Signal-Noise Ratio value is SNR - DSNR
Spurious-free dynamic range <sup>3)</sup>	SFDR CC	60	-	-	dB	$f_{MOD} = 26.67$ MHz
Output sampling rate	$f_D$ CC	3.906	-	300	kHz	16 MHz / 4096, without integrator
Pass band	$f_{PB}$ CC	1.302	-	100	kHz	Output data rate: $f_D = f_{PB} * 3$ ; without integrator
		1.302	-	10	kHz	Output data rate: $f_D = f_{PB} * 6$ ; without integrator
Pass band ripple	$df_{PB}$ CC	-0.08	-	0.08	dB	FIR filters enabled
Stop band attenuation	SBA CC	40	-	-	dB	$0.5 f_D \dots 1.0 f_D$
		45	-	-	dB	$1.0 f_D \dots 1.5 f_D$
		50	-	-	dB	$1.5 f_D \dots 2.0 f_D$
		55	-	-	dB	$2.0 f_D \dots 2.5 f_D$
		60	-	-	dB	$2.5 f_D \dots \text{OSR}/2 f_D$
DC compensation factor	DCF CC	-3	-	-	dB	$10^{-5} f_D$ , offset compensation filter enabled (FCFGMx.OCEN = 001 <sub>B</sub> )
Modulator settling time	$t_{MSET}$ CC	-	-	20	$\mu\text{s}$	After switching on, voltage regulator already running

1) On pins with overlaid GPIO function the max. limit increases by up to 25 mV due to leakage current for  $T_J > 150^\circ\text{C}$ .

2) For detailed information, refer to the User Manual chapter.

3) This parameter is valid within the defined range of  $f_{MOD}$ .

4) Gain mismatch error between the different EDSADC channels is within  $\pm 0.5\%$  if they have the same calibration strategy

---

**Electrical Specification DSADC Parameters**

- 5) Recalibration needed in case of a temperature change  $>20^{\circ}\text{C}$
- 6) These values are valid for an analog gain factor of 1. Subtract 3 dB for each higher gain factor.
- 7) For single ended input signals and gain1, the SNR is reduced by 6 dB.

### 3.9 MHz Oscillator

OSC\_XTAL is used as accurate and exact clock source. OSC\_XTAL supports 16 MHz to 40 MHz crystals external outside of the device. Support of ceramic resonators is also provided.

**Table 3-23 OSC\_XTAL**

Parameter	Symbol	Values			Unit	Note / Test Condition
		Min.	Typ.	Max.		
Input current at XTAL1	$I_{IX1}$ CC	-70	-	70	μA	$V_{IN} > 0V$ ; $V_{IN} < V_{EXT}$
Oscillator frequency	$f_{OSC}$ SR	4	-	40	MHz	Direct Input Mode selected, if shaper is not bypassed
		16	-	40	MHz	External Crystal Mode selected
Oscillator start-up time	$t_{OSCS}$ CC	-	-	3 <sup>1)</sup>	ms	$20MHz \leq f_{OSC}$ and 8pF load capacitance
Input voltage at XTAL1 <sup>2)</sup>	$V_{IX}$ SR	-0.7	-	$V_{EXT} + 0.5$	V	If shaper is not bypassed
Input amplitude (peak to peak) at XTAL1	$V_{PPX}$ SR	$0.3 * V_{EXT}$	-	$V_{EXT} + 1.0$	V	If shaper is not bypassed; $f_{OSC} > 25MHz$
		$0.35 * V_{EXT}$	-	$V_{EXT} + 1.0$	V	If shaper is not bypassed; $f_{OSC} \leq 25MHz$
Internal load capacitor	$C_{L0}$ CC	1.30	1.40	1.55	pF	enabled via bit OSCCON.CAP0EN
Internal load capacitor	$C_{L1}$ CC	3.05	3.35	3.70	pF	enabled via bit OSCCON.CAP1EN
Internal load capacitor	$C_{L2}$ CC	7.85	8.70	9.55	pF	enabled via bit OSCCON.CAP2EN
Internal load capacitor	$C_{L3}$ CC	12.05	13.35	14.65	pF	enabled via bit OSCCON.CAP3EN
Internal load stray capacitor between XTAL1 and XTAL2	$C_{XINTS}$ CC	1.15	1.20	1.25	pF	
Internal load stray capacitor between XTAL1 and ground	$C_{XTAL1}$ CC	-	2.5	4	pF	
Duty cycle at XTAL1 <sup>3)</sup>	$DC_{X1}$ SR	35	-	65	%	$V_{XTAL1} = 0.5 * V_{PPX}$
Absolute RMS jitter at XTAL1 <sup>3)</sup>	$J_{ABSX1}$ SR	-	-	28	ps	10 KHz to $f_{OSC}/2$
Slew rate at XTAL1 <sup>3)</sup>	$SR_{XTAL1}$ SR	0.3	-	-	V/ns	Maximum 30% difference between rising and falling slew rate

1)  $t_{OSCS}$  is defined from the moment when the Oscillator Mode is set to External Crystal Mode until the oscillations reach an amplitude at XTAL1 of  $0.3 * V_{EXT}$ .

This value depends on the frequency of the used external crystal. For faster crystal frequencies this value decrease.

2) For Supply ( $V_{EXT} < 5.3V$   $V_{IX}$ ) min could be down to -0.9V. For XTAL1 an input level down to -0.9V will not cause a damage or a reliability problem operating with an external crystal.

3) Square wave input signal for XTAL1.

*Note: It is strongly recommended to measure the oscillation allowance (negative resistance) in the final target system (layout) to determine the optimal parameters for the oscillator operation. Please refer to the limits specified by the crystal or ceramic resonator supplier.*

### 3.10 Back-up Clock

The back-up clock provides an alternative clock source.

**Table 3-24 Back-up Clock**

Parameter	Symbol	Values			Unit	Note / Test Condition
		Min.	Typ.	Max.		
Back-up clock accuracy before trimming	$f_{\text{BACKUT}}$ CC	70	100	130	MHz	$V_{\text{EXT}} \geq 2.97\text{V}$
Back-up clock accuracy after trimming <sup>1)</sup>	$f_{\text{BACKT}}$ CC	98	100	102	MHz	$V_{\text{EXT}} \geq 2.97\text{V}$
Standby clock	$f_{\text{SB}}$ CC	25	70	110	kHz	$V_{\text{EXT}} \geq 2.97\text{V}$

1) A short term trimming providing the accuracy required by LIN communication is possible by periodic trimming every 2 ms for temperature and voltage drifts up to temperatures of 125 celcius

### 3.11 Temperature Sensor

**Table 3-25 DTS PMS**

Parameter	Symbol	Values			Unit	Note / Test Condition
		Min.	Typ.	Max.		
Measurement time for each conversion <sup>1)</sup>	$t_M$ CC	-	-	2.7	ms	Measured from cold power-on reset release
Calibration reference accuracy	$T_{CALACC}$ CC	-1	-	1	°C	calibration points @ $T_J=-40^{\circ}\text{C}$ and $T_J=127^{\circ}\text{C}$
Accuracy over temperature range	$T_{NL}$ CC	-2	-	2	°C	$T_{CALACC}$ has to be added in addition
DTS temperature range	$T_{SR}$ SR	-40	-	170	°C	

1) After warm reset  $t_M$  is not restarted and is measured from last conversion.

**Table 3-26 DTS Core**

Parameter	Symbol	Values			Unit	Note / Test Condition
		Min.	Typ.	Max.		
Measurement time for each conversion <sup>1)</sup>	$t_M$ CC	-	-	2.7	ms	Measured from cold power-on reset release
Temperature difference between on chip temperature sensors	$\Delta T$ CC	-3	-	3	°C	
Calibration reference accuracy	$T_{CALACC}$ CC	-2	-	2	°C	calibration points @ $T_J=-40^{\circ}\text{C}$ and $T_J=127^{\circ}\text{C}$
Accuracy over temperature range	$T_{NL}$ CC	-2	-	2	°C	$T_{CALACC}$ has to be added in addition
DTS temperature range	$T_{SR}$ SR	-40	-	170	°C	

1) After warm reset  $t_M$  is not restarted and is measured from last conversion.

### 3.12 Power Supply Current

The total power supply current defined below consists of leakage and switching components.

Application relevant values are typically lower than those given in the following table and depend on the customer's system operating conditions (e.g. thermal connection or used application configurations).

The operating conditions for the parameters in the following table are:

The real (realistic) power pattern defines the following conditions:

- $T_J = 150\text{ °C}$
- $f_{SRI} = f_{CPUx} = 300\text{ MHz}$
- $f_{GTM} = 200\text{ MHz}$
- $f_{SPB} = f_{STM} = f_{BAUD1} = f_{BAUD2} = f_{ASCLINx} = 100\text{ MHz}$
- $V_{DD} = 1.275\text{ V}$
- $V_{DDP3/FLEX} = 3.366\text{ V}$
- $V_{EXT / EVRSB} = V_{DDM} = 5.1\text{ V}$
- all cores are active including two lockstep cores
- the following peripherals are inactive: HSM, HSCT, Ethernet, PSI5, I2C, FCE, and MTU

**Table 3-27 Current Consumption**

Parameter	Symbol	Values			Unit	Note / Test Condition
		Min.	Typ.	Max.		
$\Sigma$ Sum of $I_{DD}$ core and peripheral supply currents (incl. $I_{DDPORST} + \Sigma I_{DDCx0} + \Sigma I_{DDCxX} + I_{DDGTM} + I_{DDSB}$ )	$I_{DDRAIL}$ CC	-	-	1100	mA	max power pattern
		-	-	840	mA	real power pattern
$I_{DD}$ core current during active power-on reset (PORST pin held low). Leakage current of core domain. <sup>1)</sup>	$I_{DDPORST}$ CC	-	-	160	mA	$V_{DD} = 1.275\text{V};$ $T_J = 125\text{°C}$
		-	-	290	mA	$V_{DD} = 1.275\text{V};$ $T_J = 150\text{°C}$
		-	-	350	mA	$V_{DD} = 1.275\text{V};$ $T_J = 160\text{°C}$
		-	-	380	mA	$V_{DD} = 1.275\text{V};$ $T_J = 165\text{°C}$
$\Sigma$ Sum of $I_{DDP3}$ 3.3 V supply currents	$I_{DDP3RAIL}$ CC	-	-	50	mA	max power pattern incl. Flash read current and Dflash programming current.
		-	-	40 <sup>2)</sup>	mA	real power pattern incl. Flash read current and Dflash programming current.
$\Sigma$ Sum of external $I_{EXT}$ supply currents (incl. $I_{EXTFLEX} + I_{EVRSB} + I_{EXTLVDs}$ )	$I_{EXTRAIL}$ CC	-	-	56	mA	max power pattern
		-	-	50	mA	real power pattern

**Electrical Specification Power Supply Current**
**Table 3-27 Current Consumption (cont'd)**

Parameter	Symbol	Values			Unit	Note / Test Condition
		Min.	Typ.	Max.		
$I_{EXT}$ and $I_{FLEX}$ supply current	$I_{EXTFLEX}$ CC	-	-	18 <sup>3)</sup>	mA	real power pattern with port activity absent; PORST output inactive.
$I_{EVRSB}$ supply current <sup>1)</sup>	$I_{EVRSB}$ CC	-	-	8	mA	real power pattern; PMS/EVR module current considered without SCR and Standby RAM during RUN mode.
$\Sigma$ Sum of external $I_{DDM}$ supply currents (incl. $I_{DDMEVADC} + I_{DDMEDSADC}$ )	$I_{DDM}$ CC	-	-	48	mA	real power pattern; sum of currents of EDSADC and EVADC modules
$\Sigma$ Sum of all currents (incl. $I_{EXTRAIL} + I_{DDMRail} + I_{DDx3RAIL} + I_{DD}$ )	$I_{DDTOT}$ CC	-	-	978	mA	real power pattern; $T_J = 150^\circ C$
$\Sigma$ Sum of all currents with DC-DC EVRC regulator active <sup>4)</sup>	$I_{DDTOTDC3}$ CC	-	-	580	mA	real power pattern; EVRC reset settings with 72% efficiency; $V_{EXT} = 3.3V$ ; $T_J = 150^\circ C$
$\Sigma$ Sum of all currents with DC-DC EVRC regulator active <sup>4)</sup>	$I_{DDTOTDC5}$ CC	-	-	440	mA	real power pattern; EVRC reset settings with 72% efficiency; $V_{EXT} = 5V$ ; $T_J = 150^\circ C$
$\Sigma$ Sum of all currents (SLEEP mode) <sup>1)</sup>	$I_{SLEEP}$ CC	-	-	27	mA	All CPUs in idle, All peripherals in sleep, $f_{SRI/SPB} = 1 MHz$ via LPDIV divider; $T_J = 25^\circ C$
$\Sigma$ Sum of all currents (STANDBY mode) drawn at $V_{EVRSB}$ supply pin <sup>5)</sup>	$I_{STANDBY}$ CC	-	-	130 <sup>6)</sup>	$\mu A$	32 kB Standby RAM block active. SCR inactive. Power to remaining domains switched off. $T_J = 25^\circ C$ ; $V_{EVRSB} = 5V$
Maximum power dissipation <sup>7)</sup>	PD SR	-	-	2400	mW	max power pattern
		-	-	1700	mW	real power pattern

- 1) Limits are defined for real power pattern ( $V_{DD} = 1.275V$ ). For max power pattern limit has to be multiplied by the factor 1.22.
- 2) Realistic Pflash read pattern with 50% Pflash bandwidth utilization and a code mix of 50% 0s and 50% 1s. A common decoupling capacitor of at least 100nF for ( $V_{DDP3}$ ) is used. Continuous Dflash programming in burst mode with 3.3 V supply and realistic Pflash read access in parallel. Erase currents of the corresponding flash modules are less than the respective programming currents at  $V_{DDP3}$  pin. Programming and erasing flash may generate transient current spikes of up to 45 mA / 20 ns which are handled by the decoupling and buffer capacitors. This parameter is relevant for external power supply dimensioning and not for thermal considerations.
- 3) The current consumption includes only minimal port activity.

**Electrical Specification Power Supply Current**

- 4) The total current drawn from external regulator is estimated with 72% EVRC SMPS regulator efficiency. IDDTOTDCx is calculated from IDDTOT using the scaled core current  $[(I_{DD} \times V_{DD}) / (V_{in} \times \text{Efficiency})]$  and constitutes all other rail currents and IDDM.
- 5) The same current limits apply also for the other power pattern.
- 6)  $\Sigma$  Sum of all currents during RUN mode at VEVR3B supply pin is less than  $(I_{EVR3B} + 4 \text{ mA Standby RAM current} + I_{SCR3B} \text{ if SCR active})$ .  $\Sigma$  It is recommended to have atleast 100 nF decoupling capacitor at this pin. 32kB of Standby SRAM contributes less than 10uA to I standby current.
- 7) The values are only valid if all supplies are applied from external and do not contain the power losses of EVR33 and EVRC.

**Table 3-28 Module Current Consumption**

Parameter	Symbol	Values			Unit	Note / Test Condition
		Min.	Typ.	Max.		
$I_{DDP3}$ supply current for programming of a Pflash or Dflash bank <sup>1)</sup>	$I_{DDP3PROG}$ CC	-	-	25	mA	Pflash 3.3V programming current adder when using external 3.3V supply.
		-	-	9 <sup>2)</sup>	mA	Pflash 3.3V programming current adder when using external 5V supply.
$I_{EXT}$ supply current added by LVDS pads in LVDS mode <sup>1)</sup>	$I_{EXTLVDS}$ CC	-	-	9	mA	real power pattern; 6 pairs of LVDS pins active with receive function
		-	-	24	mA	real power pattern; 6 pairs of LVDS pins active with transmit function

**Electrical Specification Power Supply Current**
**Table 3-28 Module Current Consumption (cont'd)**

Parameter	Symbol	Values			Unit	Note / Test Condition
		Min.	Typ.	Max.		
$\Sigma$ Sum of external $I_{DDM}$ supply currents (incl. $I_{DDMEVADC} + I_{DDMEDSADC}$ )	$I_{DDM}$ CC	-	-	32	mA	real power pattern; current for EDSADC modules only and EVADC modules are inactive; 8 EDSADC channels active continuously.
		-	-	45 <sup>3)</sup>	mA	max power pattern; current for EDSADC modules only and EVADC modules are inactive; all EDSADC channels active continuously.
		-	-	16	mA	real power pattern; current for EVADC modules only and EDSADC modules are inactive; 12 EVADC modules active.
		-	-	20 <sup>4)</sup>	mA	max power pattern; current for EVADC modules only and EDSADC modules are inactive; all EVADC modules active.
$I_{DDP3}$ supply current for erasing of a Pflash or Dflash bank	$I_{DDP3ERASE}$ CC	-	-	25	mA	Pflash 3.3V erasing current adder when using external 3.3V supply.
SCR 8-bit Standby Controller current incl. PMS in STANDBY Mode drawn at $V_{EVRSB}$ supply pin	$I_{SCR SB}$ CC	-	-	7 <sup>5)</sup>	mA	SCR power pattern incl. PMS current consumption with fback clock active; $f_{SYS\_SCR} = 20\text{MHz}$ ; $T_J = 150^\circ\text{C}$
		-	0.150	-	mA	SCR power pattern incl. PMS current consumption with fback inactive; $f_{SYS\_SCR} = 70\text{kHz}$ ; $T_J = 25^\circ\text{C}$
SCR 8-bit Standby Controller CPU in IDLE mode <sup>6)</sup>	$I_{SCRIDLE}$ CC	-	-	3.5	mA	real power pattern. CPU set into idle mode.

1) The same current limits apply also for the other power pattern.

2) During Pflash programming at 5V, additional 3 mA is drawn at VEXT supply rail.

3) A single DS channel instance consumes 4 mA.

**Electrical Specification Power Supply Current**

- 4) A single VADC unit consumes 1.3 mA.
- 5) If SCR ADCOMP is activated, an additional 0.6 mA adder is to be considered.
- 6) Limits are defined for real power pattern ( $V_{DD}=1.275V$ ). For max power pattern limit has to be multiplied by the factor 1.22.

**Table 3-29 Module Core Current Consumption**

Parameter	Symbol	Values			Unit	Note / Test Condition
		Min.	Typ.	Max.		
$I_{DD}$ core current of CPUx main core with CPUx lockstep core inactive	$I_{DDC_{x0}}$ CC	-	-	70	mA	max power pattern; IPC=1.2
		-	-	45	mA	real power pattern; IPC=0.6
$I_{DD}$ core current of CPUx main core with CPUx lockstep core active	$I_{DDC_{xx}}$ CC	-	-	$I_{DDC_{x0}} + 50$	mA	max power pattern; IPC=1.2
		-	-	$I_{DDC_{x0}} + 40$	mA	real power pattern; IPC=0.6
$I_{DD}$ core current added by GTM	$I_{DDGTM}$ CC	-	-	125	mA	max power pattern
		-	-	100	mA	real power pattern; TIMx, TOMx, ATOMx, MCSx active. 3 clusters at 200 MHz.
		-	-	50	mA	TIMx, TOMx active at 100MHz. ATOMx, MCSx, DPLL inactive. 2 clusters at 100 MHz.
$I_{DD}$ core current added by HSM	$I_{DDHSM}$ CC	-	-	20 <sup>1)</sup>	mA	max power pattern; HSM running at 100MHz.
$I_{DD}$ core dynamic current added by LBIST	$I_{DDLBI}$ CC	-	-	80 <sup>2)</sup>	mA	LBIST Configuration A; $1.2V \leq V_{DD}$
$I_{DD}$ core dynamic current added by MBIST	$I_{DDMBI}$ CC	-	-	200	mA	fMBIST = 300MHz; tMBIST < 6ms. MTU Ganging procedure for SRAM test and initialization; VDD = 1.375V.

- 1) The current consumption includes basic HSM activity incl. AES module.
- 2) LBIST is executed either during start-up phase or can be triggered by application software. Secondary voltage monitors are inactive during the LBIST execution time ( $t_{LBIST}$ ). During the start-up phase externally supplied  $V_{DD}$  voltage has to be equal or greater than 1.2V ( $V_{DD}$  nominal - 4%) for static accuracy.  
If  $V_{DD}$  is supplied internally by EVRC, EVRC takes care not to violate the  $V_{DD}$  1.2V static under voltage limit.

### 3.12.1 Calculating the 1.25 V Current Consumption

The current consumption of the 1.25 V rail is composed of two parts:

- Static current consumption
- Dynamic current consumption

---

**Electrical Specification Power Supply Infrastructure and Supply Start-up**

The static current consumption is related to the device temperature  $T_J$  and the dynamic current consumption depends on the configured clocking frequencies and the software application executed. These two parts need to be added in order to get the rail current consumption.

(3.1)

$$I_0 = 4,7777 \left[ \frac{\text{mA}}{\text{C}} \right] \times e^{0,02273 \times T_J[\text{C}]}$$

(3.2)

$$I_0 = 11,3778 \left[ \frac{\text{mA}}{\text{C}} \right] \times e^{0,02114 \times T_J[\text{C}]}$$

**Equation (3.1)** defines the typical static current consumption and **Equation (3.2)** defines the maximum static current consumption. Both functions are valid for  $V_{DD} = 1.275 \text{ V}$ .

### 3.13 Power Supply Infrastructure and Supply Start-up

### 3.13.1 Supply Ramp-up and Ramp-down Behavior

Start-up slew rates for supply rails shall comply to SR (see [Table 3-33](#) Supply Ramp).

#### 3.13.1.1 Single Supply mode (a)

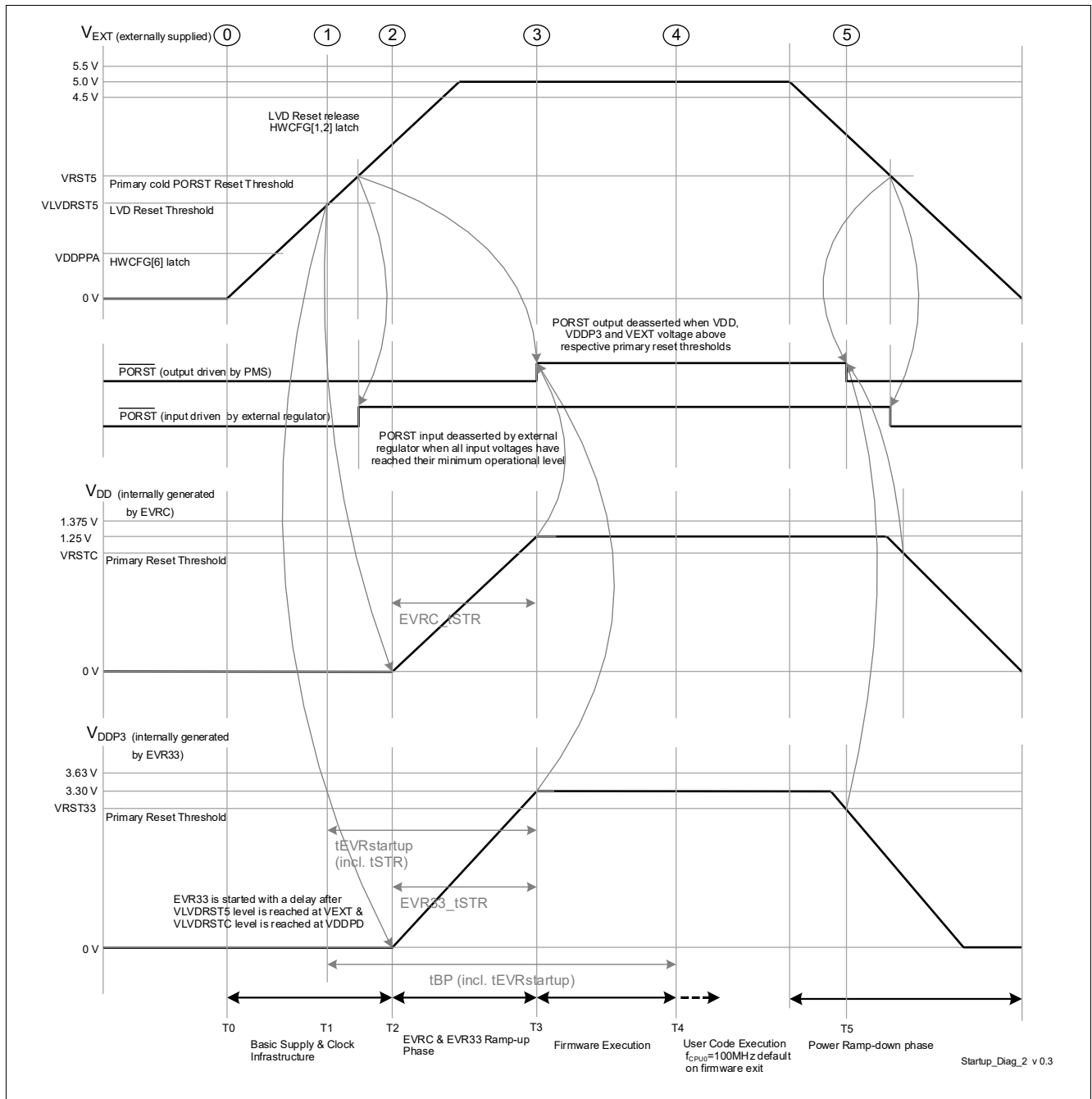

Figure 3-3 Single Supply mode (a) - VEXT (5 V) single supply

VEXT = 5 V single supply mode. VDD and VDDP3 are generated internally by the EVRC and EVR33 internal regulators.

### Electrical Specification Power Supply Infrastructure and Supply Start-up

- The rate at which current is drawn from the external regulator ( $dI_{EXT}/dt$ ) is limited during the basic infrastructure and EVRx regulator start-up phase (T0 up to T2) to a maximum of 100 mA with 100  $\mu$ s settling time. Start-up slew rates for supply rails shall comply to datasheet parameter SR. The slope is defined as the maximal tangential slope between 0% to 100% voltage level. Actual waveform may not represent the specification.
- Furthermore it is also ensured that the current drawn from the regulator ( $dI_{DD}/dt$ ) is limited during the Firmware start-up phase (T3 up to T4) to a maximum of 100 mA with 100  $\mu$ s settling time.
- PORST is active/asserted when either PORST (input) or PORST (output) is active/asserted.
- PORST (input) active means that the reset is held active by external agents by pulling the PORST pin low. It is recommended to keep the PORST (input) asserted until the external supply is above the respective primary reset threshold.
- PORST (output) active means that  $\mu$ C asserts the reset internally and drives the PORST pin low thus propagating the reset to external devices. The PORST (output) is asserted by the  $\mu$ C when at least one among the three supply domains (VDD, VDDP3 or VEXT) violate their primary under-voltage reset thresholds. The PORST (output) is de-asserted by the  $\mu$ C when all supplies are above their primary reset thresholds and the basic supply and clock infrastructure is available. During reset release at T3, the load jump of up to 150 mA ( $dI_{DD}$ ) is expected.
- The power sequence as shown in [Figure 3-3](#) is enumerated below
  - T1 up to T2 refers to the period in time when basic supply and clock infrastructure components are available as the external supply ramps up. The bandgap and internal clock sources are started. The supply mode is evaluated based on the HWCFG[2:1,4,5,6] and TESTMODE pins. T1 up to T2 refers to the period in time when basic supply and clock infrastructure components are available as the external supply ramps up. The bandgap and internal clock sources are started. The supply mode is evaluated based on the HWCFG[2:1,6] pins. These events are initiated after LVD reset release at T1. LVD reset is released the both input voltages VEXT and VEVR SB are above VLVD RST5 and VLVD RST SB levels correspondingly. Internal pre-regulator VDDPD output voltage is above VLVD RST C level.
  - T2 refers to the point in time where consequently a soft start of EVRC and EVR33 regulators are initiated. PORST (input) does not have any affect on EVR33 or EVRC output and regulators continue to generate the respective voltages though PORST is asserted and the device is in reset state. The generated voltage follows a soft ramp-up over the tSTR (datasheet parameter) time to avoid overshoots.
  - T3 refers to the point in time when all supplies are above their primary reset thresholds denoted by VRST5, VRST33 and VRSTC supply voltage levels. EVRC and EVR33 regulators have ramped up. PORST (output) is de-asserted and HWCFG[3:5] pins are latched on PORST rising edge by SCU. Firmware execution is initiated. The time between T1 and T3 is documented as tEVR startup (datasheet parameter).
  - T4 refers to the point in time when Firmware execution is completed and User code execution starts with CPU0 at a default frequency of 100 MHz. The time between T0 and T4 is documented as tBP (datasheet parameter).
  - T5 refers to the point in time during the ramp-down phase when at least one of the externally provided or generated supplies (VDD, VDDP3 or VEXT) drop below their respective primary under-voltage reset thresholds.

### 3.13.1.2 Single Supply mode (e)

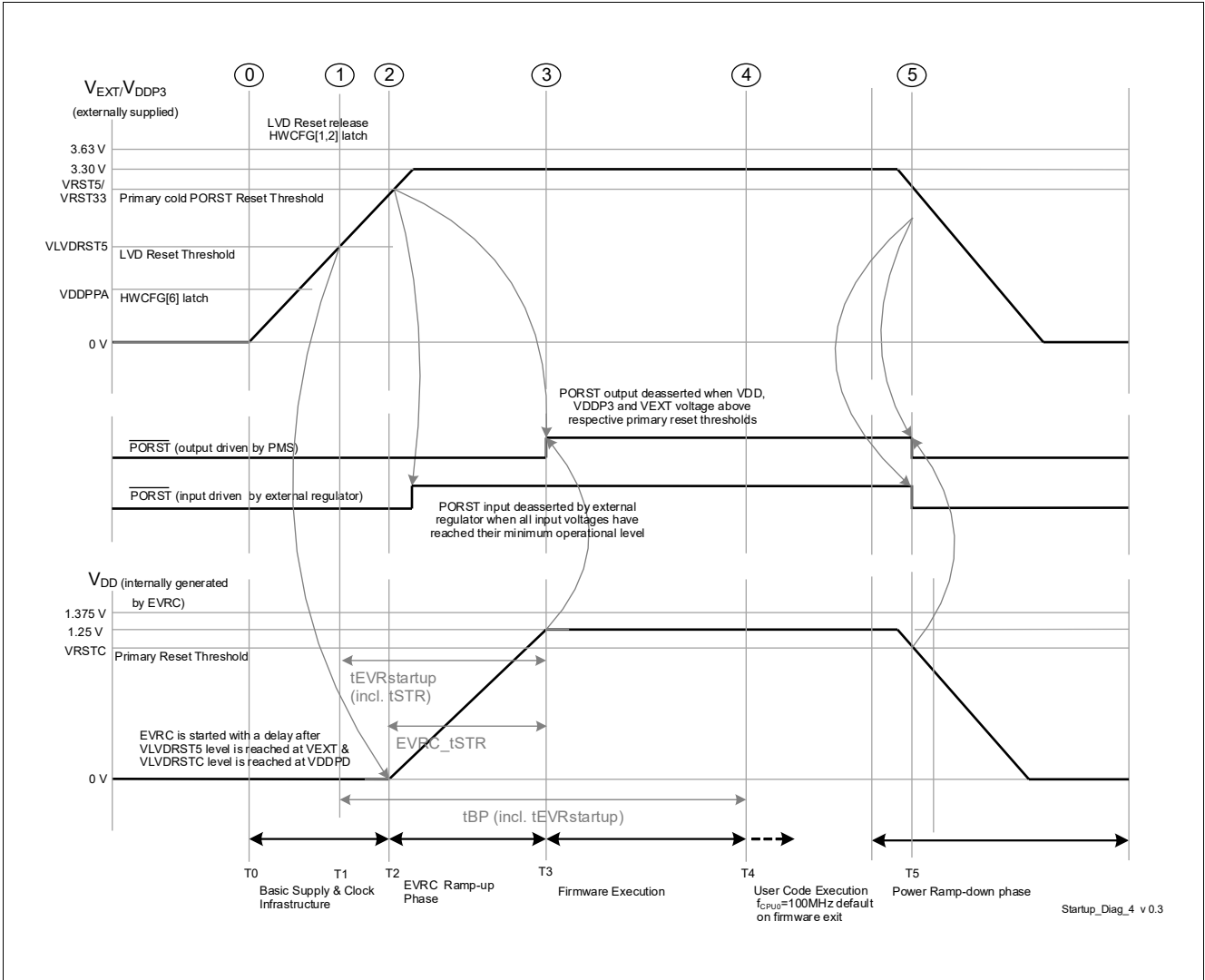

Figure 3-4 Single Supply mode (e) - (VEXT & VDDP3) 3.3 V single supply

VEXT = VDDP3 = 3.3 V single supply mode. VDD is generated internally by the EVRC regulator.

- The rate at which current is drawn from the external regulator ( $dI_{EXT}/dt$ ) is limited in the Start-up phase to a maximum of 100 mA with 100  $\mu$ s settling time. Start-up slew rates for supply rails shall comply to datasheet parameter SR. The slope is defined as the maximal tangential slope between 0% to 100% voltage level. Actual waveform may not represent the specification.
- PORST is active/asserted when either PORST (input) or PORST (output) is active/asserted.
- PORST (input) active means that the reset is held active by external agents by pulling the PORST pin low. It is recommended to keep the PORST (input) asserted until the external supply is above the respective primary reset threshold.
- PORST (output) active means that  $\mu$ C asserts the reset internally and drives the PORST pin low thus propagating the reset to external devices. The PORST (output) is asserted by the  $\mu$ C when at least one among the three supply domains (VDD, VDDP3 or VEXT) violate their primary under-voltage reset thresholds. The PORST (output) is de-asserted by the  $\mu$ C when all supplies are above their primary reset thresholds and the

## Electrical Specification Power Supply Infrastructure and Supply Start-up

basic supply and clock infrastructure is available. During reset release at T3, the load jump of upto 150 mA (dIDD) is expected.

- The power sequence as shown in [Figure 3-4](#) is enumerated below
  - T1 up to T2 refers to the period in time when basic supply and clock infrastructure components are available as the external supply ramps up. The bandgap and internal clock sources are started. The supply mode is evaluated based on the HWCFG[2:1,4,5,6] and TESTMODE pins. T1 up to T2 refers to the period in time when basic supply and clock infrastructure components are available as the external supply ramps up. The bandgap and internal clock sources are started. The supply mode is evaluated based on the HWCFG[2:1,6] pins. These events are initiated after LVD reset release at T1. LVD reset is released the both input voltages VEXT and VEVR SB are above VLVD RST5 and VLVD RSTSB levels correspondingly. Internal pre-regulator VDDPD output voltage is above VLVD RSTC level.
  - T2 refers to the point in time where consequently a soft start of EVRC regulator is initiated. PORST (input) does not have any affect on EVRC output and regulators continue to generate the respective voltages though PORST is asserted and the device is in reset state. The generated voltage follows a soft ramp-up over the tSTR (datasheet parameter) time to avoid overshoots.
  - T3 refers to the point in time when all supplies are above their primary reset thresholds denoted by VRST5, VRST33 and VRSTC supply voltage levels. EVRC regulator has ramped up. PORST (output) is de-asserted and HWCFG[3:5] pins are latched on PORST rising edge by SCU. Firmware execution is initiated. The time between T1 and T3 is documented as tEVRstartup (datasheet parameter).
  - T4 refers to the point in time when Firmware execution is completed and User code execution starts with CPU0 at a default frequency of 100 MHz. The time between T0 and T4 is documented as tBP (datasheet parameter).
  - T5 refers to the point in time during the ramp-down phase when at least one of the externally provided or generated supplies (VDD, VDDP3 or VEXT) drop below their respective primary under-voltage reset thresholds.

### 3.13.1.3 External Supply mode (d)

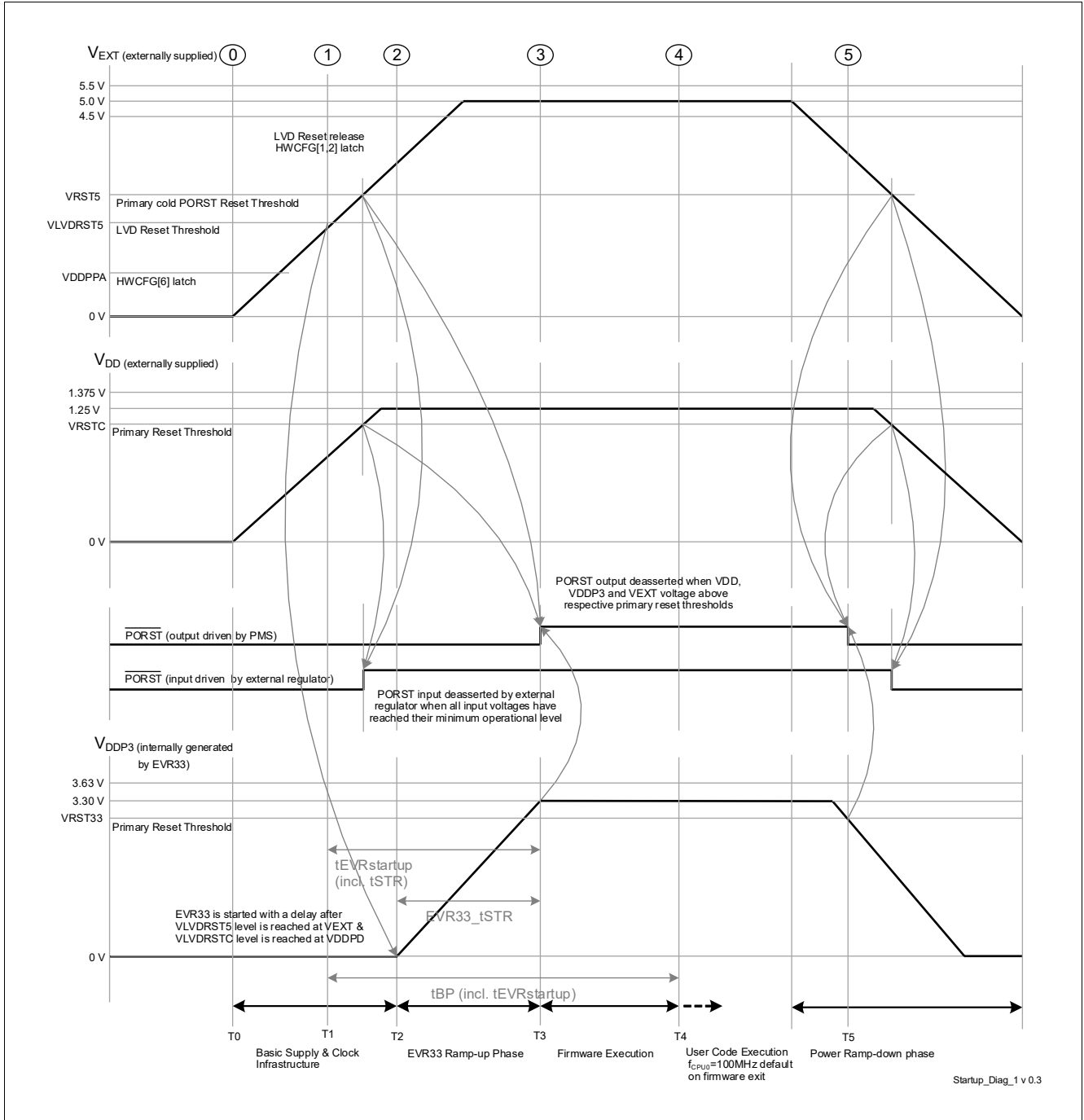

**Figure 3-5 External Supply mode (d) - VEXT and VDD externally supplied**

VEXT = 5 V and VDD supplies are externally supplied. 3.3V is generated internally by the EVR33 regulator.

- External supplies VEXT and VDD may ramp-up or ramp-down independent of each other with regards to start, rise and fall time(s). Start-up slew rates for supply rails shall comply to datasheet parameter SR. The slope is defined as the maximal tangential slope between 0% to 100% voltage level. Actual waveform may not represent the specification. It is expected that during start-up, VEXT ramps up before VDD rail. If VDD voltage

## Electrical Specification Power Supply Infrastructure and Supply Start-up

rail is ramped up before VEXT; VDD supply overshoots during start-up shall be limited within the operational voltage range.

- The rate at which current is drawn from the external regulator (dIEXT /dt or dIDD /dt) is limited in the Start-up phase to a maximum of 100 mA with 100 us settling time.
- PORST is active/asserted when either PORST (input) or PORST (output) is active/asserted.
- PORST (input) active means that the reset is held active by external agents by pulling the PORST pin low. It is recommended to keep the PORST (input) asserted until all the external supplies are above their primary reset thresholds.
- PORST (output) active means that  $\mu$ C asserts the reset internally and drives the PORST pin low thus propagating the reset to external devices. The PORST (output) is asserted by the  $\mu$ C when at least one among the three supply domains (VDD, VDDP3 or VEXT) violate their primary under-voltage reset thresholds. The PORST (output) is de-asserted by the  $\mu$ C when all supplies are above their primary reset thresholds and the basic supply and clock infrastructure is available. During reset release at T3, the load jump of upto 150 mA (dIDD) is expected.
- The power sequence as shown in [Figure 3-5](#) is enumerated below
  - T1 up to T2 refers to the period in time when basic supply and clock infrastructure components are available as the external supply ramps up. The bandgap and internal clock sources are started. The supply mode is evaluated based on the HWCFG[2:1,4,5,6] and TESTMODE pins. T1 up to T2 refers to the period in time when basic supply and clock infrastructure components are available as the external supply ramps up. The bandgap and internal clock sources are started. The supply mode is evaluated based on the HWCFG[2:1,6] pins. These events are initiated after LVD reset release at T1. LVD reset is released the both input voltages VEXT and VEVR5B are above VLVD RST5 and VLVD RST5B levels correspondingly. Internal pre-regulator VDDPD output voltage is above VLVD RSTC level.
  - T2 refers to the point in time where consequently a soft start of EVR33 regulator is initiated. PORST (input) does not have any affect on EVR33 output and regulators continue to generate the respective voltages though PORST is asserted and the device is in reset state. The generated voltage follows a soft ramp-up over the tSTR (datasheet parameter) time to avoid overshoots.
  - T3 refers to the point in time when all supplies are above their primary reset thresholds denoted by VRST5, VRST33 and VRSTC supply voltage levels. EVR33 regulators has ramped up. PORST (output) is de-asserted and HWCFG[3:5] pins are latched on PORST rising edge by SCU. Firmware execution is initiated. The time between T1 and T3 is documented as tEVRstartup (datasheet parameter).
  - T4 refers to the point in time when Firmware execution is completed and User code execution starts with CPU0 at a default frequency of 100 MHz. The time between T0 and T4 is documented as tBP (datasheet parameter).
  - T5 refers to the point in time during the ramp-down phase when at least one of the externally provided or generated supplies (VDD, VDDP3 or VEXT) drop below their respective primary under-voltage reset thresholds.

### 3.13.1.4 External Supply mode (h)

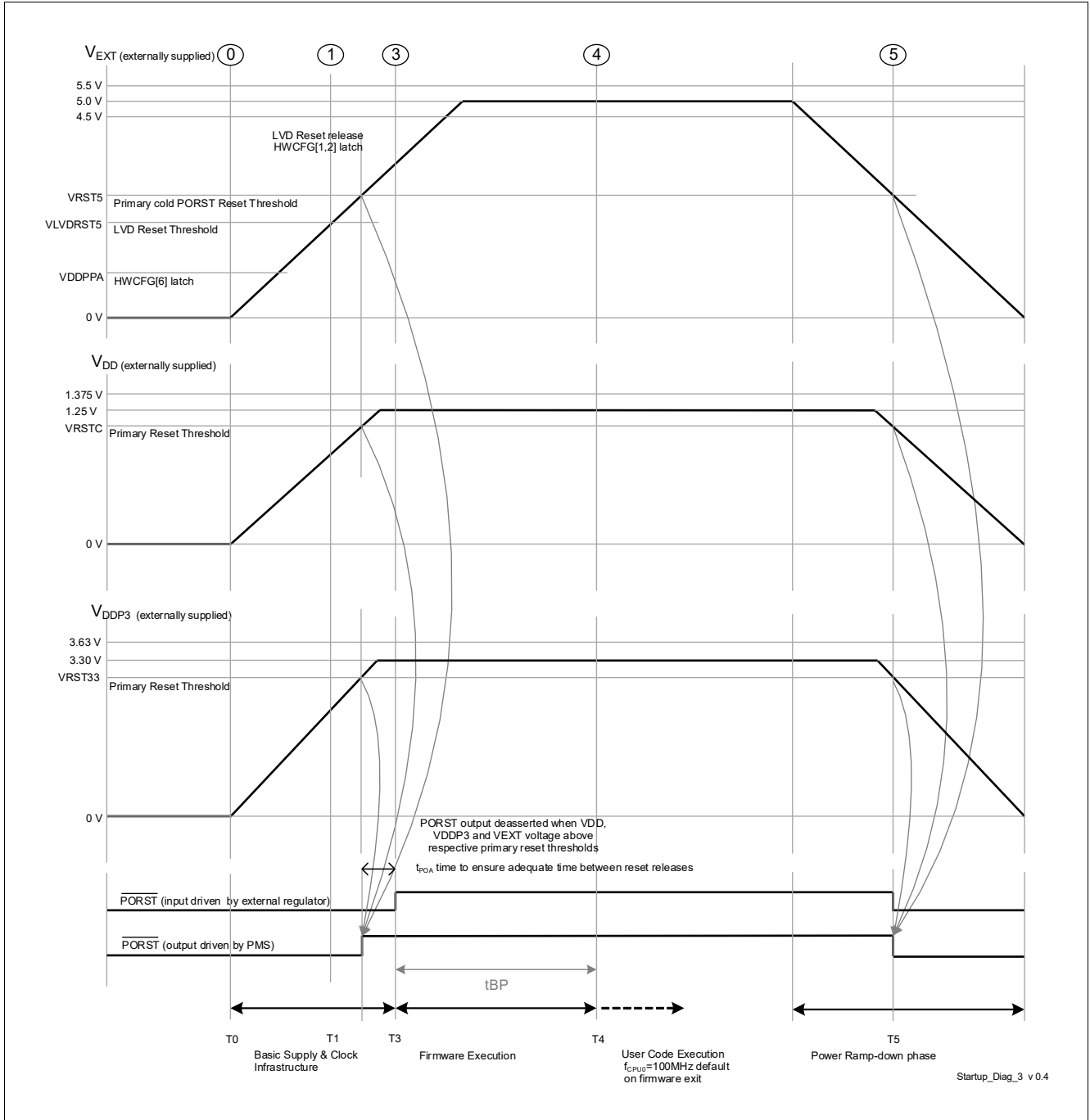

**Figure 3-6 External Supply mode (h) - VEXT, VDDP3 & VDD externally supplied**

All supplies, namely VEXT, VDDP3 & VDD are externally supplied.

- External supplies VEXT, VDDP3 & VDD may ramp-up or ramp-down independent of each other with regards to start, rise and fall time(s). Start-up slew rates for supply rails shall comply to datasheet parameter SR. The slope is defined as the maximal tangential slope between 0% to 100% voltage level. Actual waveform may not represent the specification. It is expected that during start-up, VEXT ramps up before VDDP3 and VDD rails. If smaller voltage rails are ramped up before VEXT; VDD and VDDP3 supply overshoots during start-up shall be limited within the operational voltage ranges of the respective rails.

---

**Electrical Specification Power Supply Infrastructure and Supply Start-up**

- The rate at which current is drawn from the external regulator (dIEXT /dt, dIDD /dt or dIDDP3 /dt) is limited in the Start-up phase to a maximum of 100 mA with 100 us settling time.
- PORST is active/asserted when either PORST (input) or PORST (output) is active/asserted.
- PORST (input) active means that the reset is held active by external agents by pulling the PORST pin low. It is recommended to keep the PORST (input) asserted until all the external supplies are above their primary reset thresholds.
- PORST (output) active means that  $\mu\text{C}$  asserts the reset internally and drives the PORST pin low thus propagating the reset to external devices. The PORST (output) is asserted by the  $\mu\text{C}$  when at least one among the three supply domains (VDD, VDDP3 or VEXT) violate their primary under-voltage reset thresholds. The PORST (output) is de-asserted by the  $\mu\text{C}$  when all supplies are above their primary reset thresholds and the basic supply and clock infrastructure is available. During reset release at T3, the load jump of upto 150 mA (dIDD) is expected.
- The power sequence as shown in [Figure 3-6](#) is enumerated below
  - T1 up to T3 refers to the period in time when basic supply and clock infrastructure components are available as the external supply ramps up. The bandgap and internal clock sources are started. The supply mode is evaluated based on the HWCFG[2:1,4,5,6] and TESTMODE pins. T1 up to T2 refers to the period in time when basic supply and clock infrastructure components are available as the external supply ramps up. The bandgap and internal clock sources are started. The supply mode is evaluated based on the HWCFG[2:1,6] pins. These events are initiated after LVD reset release at T1. LVD reset is released the both input voltages VEXT and VEVR SB are above VLVD RST5 and VLVD RSTSB levels correspondingly. Internal pre-regulator VDDPD output voltage is above VLVD RSTC level.
  - T3 refers to the point in time when all supplies are above their primary reset thresholds denoted by VRST5, VRST33 and VRSTC supply voltage levels. PORST (output) is de-asserted and HWCFG[3:5] pins are latched on PORST rising edge by SCU. Firmware execution is initiated.
  - T4 refers to the point in time when Firmware execution is completed and User code execution starts with CPU0 at a default frequency of 100 MHz. The time between T0 and T4 is documented as tBP (datasheet parameter).
  - T5 refers to the point in time during the ramp-down phase when at least one of the externally provided supplies (VDD, VDDP3 or VEXT) drop below their respective primary under-voltage reset thresholds.

### 3.14 Reset Timing

**Table 3-30 Reset**

Parameter	Symbol	Values			Unit	Note / Test Condition
		Min.	Typ.	Max.		
Application Reset Boot Time	$t_B$ CC	-	-	400	$\mu$ s	operating with max. frequencies, with valid BMI header
System Reset Boot Time	$t_{BS}$ CC	-	-	1.1	ms	RAM initialization and HSM boot time are not included, with valid BMI header
Cold Power on Reset Boot Time <sup>1)</sup>	$t_{BP}$ CC	-	-	3.1	ms	$dVEXT/dT=1V/ms$ . $VEXT>VLVDRST5$ . Boot time after Cold PORST including EVR ramp-up and Firmware execution time; RAM initialization and HSM boot time are not included.
		-	-	1.6	ms	Firmware execution time after PORST release without EVR ramp-up; RAM initialization and HSM boot time is not included
Minimum cold PORST reset hold time in case of power fail event issued by EVR primary monitors	$t_{EVRPOR}$ CC	10 <sup>2)</sup>	-	-	$\mu$ s	
PMS Infrastructure, EVRC and EVR33 overall start-up time till cold PORST reset release	$t_{EVRstartup}$ CC	-	-	1	ms	$dV/dT=1V/ms$ . EVRC and EVR33 active
Minimum PORST active hold time externally after power supplies are stable at operating levels after start-up	$t_{POA}$ SR	1 <sup>3)</sup>	-	-	ms	
Configurable PORST digital filter delay in addition to analog pad filter delay	$t_{PORSTDF}$ CC	600	-	1200	ns	
Warm Reset Sequencing Delay	$t_{WARMRSTSEQ}$ CC	-	-	180	$\mu$ s	
HWCFG pins hold time from ESR0 rising edge	$t_{HDH}$ CC	$16 / f_{SPB}$	-	-	ns	

## Electrical Specification Reset Timing

Table 3-30 Reset (cont'd)

Parameter	Symbol	Values			Unit	Note / Test Condition
		Min.	Typ.	Max.		
HWCFG pins setup time to ESR0 rising edge	$t_{HDS}$ CC	0	-	-	ns	
Ports inactive after ESR0 reset active	$t_{PI}$ CC	$8000/f_{BAC}$ KT	-	$18000/f_{BA}$ CKT	s	
Ports inactive after PORST reset active	$t_{PIP}$ CC	-	-	150	ns	
Hold time from PORST rising edge	$t_{POH}$ SR	150	-	-	ns	
Setup time to PORST rising edge	$t_{POS}$ SR	0	-	-	ns	
Warm PORST reset boot time	$t_{BWP}$ CC	-	-	1.3	ms	without RAM initialization
LBIST execution time extending the boot time	$t_{LBIST}$ CC	-	-	6	ms	LBIST Configuration A; $1.2V \leq V_{DD}$
SCR reset boot time	$t_{SCR}$ CC	-	-	5	$\mu$ s	User Mode 0
		-	-	16	$\mu$ s	User Mode 1
		-	13.3	-	$\mu$ s	WDT double bit ECC, soft reset
Minimum external supplies hold time after warm reset assertion	$t_{SUPHOLD}$ CC	-	-	250	$\mu$ s	external supplies are $V_{EVRSB}$ , $V_{EXT}$ , $V_{FLEX}$ , $V_{DDM}$ , $V_{DDP3}$ and $V_{DD}$

- 1) RAM initialization add 500 $\mu$ s in addition.
- 2) Cold PORST reset is driven by uC and maintained in an extended voltage range between VDDPPA limit and absolute maximum rating VEXT/VEVRSB voltage limits.
- 3) The reset release on supply ramp-up or supply restoration is delayed by a voltage hysteresis of 1.5% (default value) above the undervoltage reset limit implemented on VEXT, VDDP3 and VDD rails. This mechanism helps to avoid multiple consecutive cold PORST events during slow supply ramp-ups owing to voltage drop/current jumps when reset is released.

Electrical Specification Reset Timing

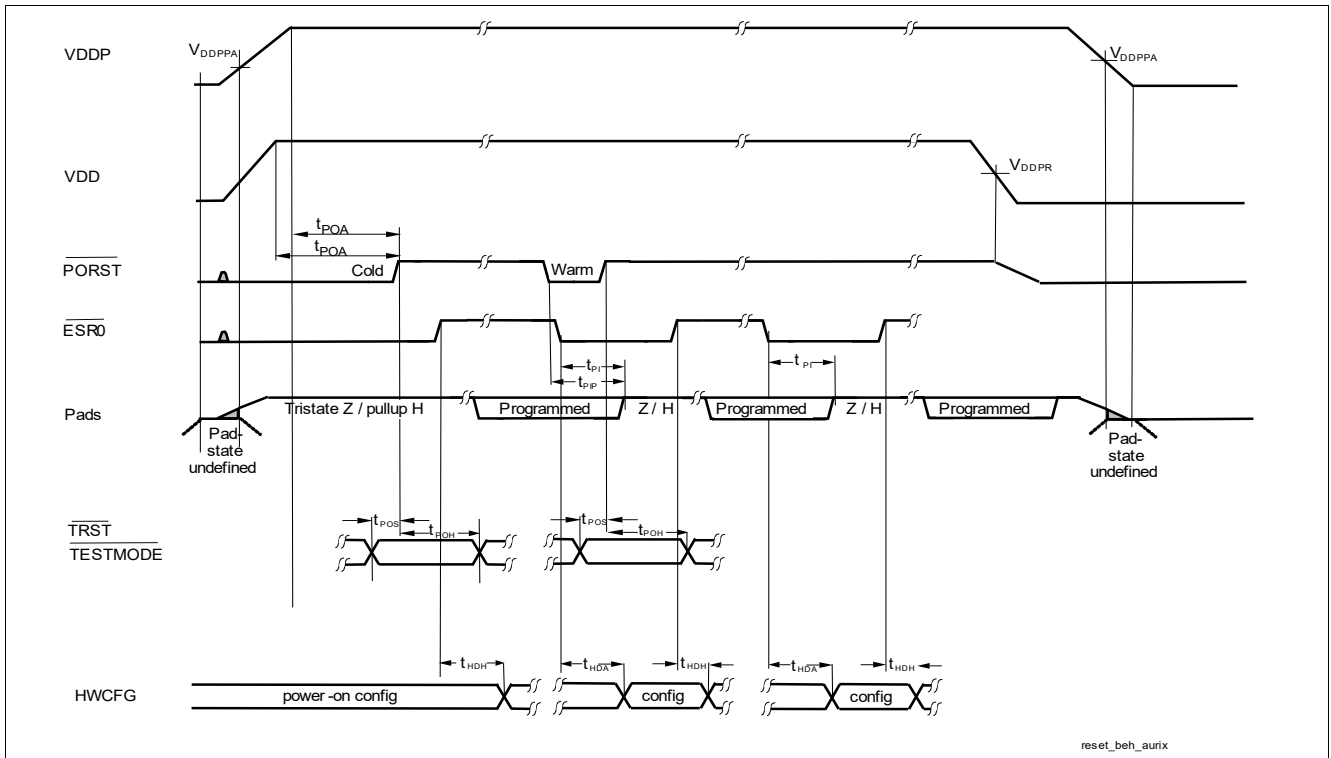

Figure 3-7 Power, Pad and Reset Timing

## 3.15 PMS

Table 3-31 EVR33 LDO

Parameter	Symbol	Values			Unit	Note / Test Condition
		Min.	Typ.	Max.		
Input voltage range	$V_{IN}$ SR	3.60 <sup>1)</sup>	-	5.50	V	Normal RUN mode
		2.97 <sup>2)</sup>	-	5.50	V	Low voltage cranking mode
Output voltage operational range including load/line regulation and aging <sup>3)</sup>	$V_{OUT}$ CC	2.97	3.3	3.63	V	Normal RUN mode
		2.60	3.3	3.63	V	Low voltage cranking mode; $I_{DDP3}=50mA$
Output $V_{DDx3}$ static voltage accuracy after trimming and aging without dynamic load/line regulation.	$V_{OUTT}$ CC	3.225	3.3	3.375	V	Normal RUN mode
		2.78	3.3	3.375	V	Low voltage cranking mode; $I_{DDP3}=50mA$
Output buffer capacitance on $V_{OUT}$	$C_{OUT}$ SR	1.45	2.2	3	$\mu F$	
Output buffer capacitor ESR	$C_{OUTESR}$ SR	-	-	100 <sup>4)</sup>	mOhm	$f > 0.5MHz$ ; $f < 10MHz$
Maximum output current of the regulator	$I_{MAX}$ CC	60 <sup>5)</sup>	-	-	mA	Normal RUN mode
Startup time	$t_{STR}$ CC	-	500	1000	$\mu s$	Normal RUN mode
External $V_{IN}$ supply ramp <sup>6)</sup>	$dV_{in}/dt$ SR	-	1	-	V/ms	
Ripple on Output Voltage	$\Delta V_{OUTTC}$ CC	-	-	33	mV	$V_{EXT} \geq 2.97V$ ; $V_{EXT} \leq 5.5V$ ; $I_{OUTTC} \geq 10mA$ ; $I_{OUTTC} \leq 60mA$ ; $\Delta V_{OUTTC} = (\text{peak to peak ripple} / 2)$
Load step response <sup>7)</sup>	$dV_{out}/dI_{out}$ CC	-165	-	-	mV	Normal RUN mode; $dI=10$ to $60mA$ ; $dt=20ns$ ; $T_{settle}=20us$
		-	-	165	mV	Normal RUN mode; $dI=60$ to $10mA$ ; $dt=20ns$ ; $T_{settle}=20us$
		-180	-	-	mV	Low voltage cranking mode; $dI=10$ to $50mA$ ; $dt=20ns$ ; $T_{settle}=20us$
		-	-	180	mV	Low voltage cranking mode; $dI=50$ to $10mA$ ; $dt=20ns$ ; $T_{settle}=20us$

**Table 3-31 EVR33 LDO (cont'd)**

Parameter	Symbol	Values			Unit	Note / Test Condition
		Min.	Typ.	Max.		
Line step response	$dV_{out}/dV_{in}$ CC	-	-	40	mV	$dV_{in}/dT=1V/ms$ ; $dV=3.6$ to $5V$ ; $I_{MAX}=60mA$ ; $\Delta V_{OUTTC}$ is included
		-40	-	-	mV	$dV_{in}/dT=1V/ms$ ; $dV=5$ to $3.6V$ ; $I_{MAX}=60mA$ ; $\Delta V_{OUTTC}$ is included
		-	-	280	mV	$dV_{in}/dT=50V/ms$ ; $dV=3.6$ to $5V$ ; $I_{MAX}=60mA$
		-165	-	-	mV	$dV_{in}/dT=50V/ms$ ; $dV=5$ to $3.6V$ ; $I_{MAX}=60mA$

- 1) A maximum pass device dropout voltage of 300mV is included in the minimum input voltage to ensure optimal pass device performance during normal operation.
- 2) VEXT Input voltage drop up to 2.97V leading to VDDP3 output voltage drop upto 2.6V can be tolerated if Flash is switched before to low performance mode.
- 3) No external inductive load permissible if EVR33 is used.
- 4) It is also recommended that the resistance of the supply trace from the pin to the EVR output capacitor is less than 100 mOhm. An additional decoupling capacitor of 100nF shall be located close to the pin before Cout.
- 5) IMAX is limited to 40 mA incase of Low voltage mode (cranking case) with on chip pass devices. In case EVR33 is not used, Injection current into 3.3V VDDP3 supply rail with active sink on 5V VEXT rail should be limited to 500 mA if during power sequencing 3.3V is supplied before 5V by external regulator.
- 6) EVR is robust against residual voltage ramp-up starting between 0 - 2.97 V. A VEXT voltage ramp range between 0.5V/min upto 120V/ms is covered in robustness validation. The generated voltage itself follows a soft ramp-up over the tSTR time to avoid overshoots.
- 7) Settling time is defined until output voltage is within +/-1% of the mean(VOUTT) of the individual device.

**Table 3-32 Supply Monitors**

Parameter	Symbol	Values			Unit	Note / Test Condition
		Min.	Typ.	Max.		
Primary Undervoltage Reset threshold for $V_{DDP3}$ before trimming <sup>1)</sup>	$V_{RST33}$ CC	-	-	3.00	V	by reset release before EVR trimming on supply ramp-up
Primary undervoltage reset threshold for $V_{DD}$ before trimming	$V_{RSTC}$ CC	-	-	1.138	V	by reset release before trimming on supply ramp-up including 2 LSB voltage Hysteresis
$V_{EXT}$ primary undervoltage monitor accuracy after trimming <sup>2)</sup>	$V_{EXTPRIUV}$ CC	2.86	2.92	2.97	V	$V_{EXT}$ = Undervoltage cold PORST Primary Monitor Threshold
$V_{DDP3}$ primary undervoltage monitor accuracy after trimming <sup>2)</sup>	$V_{DDP3PRIUV}$ CC	2.86 <sup>3)</sup>	2.90	2.97	V	VDDP3 = Undervoltage cold PORST Primary Monitor Threshold
$V_{DD}$ primary undervoltage monitor accuracy after trimming <sup>2)</sup>	$V_{DDPRIUV}$ CC	1.08 <sup>3)</sup>	1.105	1.125	V	VDD = Undervoltage cold PORST Primary Monitor Threshold

**Table 3-32 Supply Monitors (cont'd)**

Parameter	Symbol	Values			Unit	Note / Test Condition
		Min.	Typ.	Max.		
EVR primary monitor measurement latency for a new supply value	$t_{PRIUV}$ CC	-	-	300	ns	The supply ramp / line jump slope is limited to 50V/ms for $V_{EXT}$ , $V_{DDP3}$ and $V_{DD}$ rails.
$V_{EXT}$ , $V_{DDM}$ & $V_{EVR SB}$ secondary supply monitor accuracy after trimming <sup>4) 5)</sup>	$V_{EXTMON}$ CC	3.2	3.3	3.4	V	SWDxxVAL, VDDMxxVAL & SBxxVAL monitoring threshold=3.3V=90h(OV,UV). EVRMONFILT.SWDFI L=1.
		4.5	4.6	4.7	V	SWDxxVAL, VDDMxxVAL & SBxxVAL monitoring threshold=4.6V=C8h(UV)/C9h(OV). EVRMONFILT.SWDFI L=1
		5.3	5.4	5.5	V	SWDxxVAL, VDDMxxVAL & SBxxVAL monitoring threshold=5.4V=EAh(UV)/ECh(OV). EVRMONFILT.SWDFI L=1
		4.9	5.0	5.1	V	SWDxxVAL, VDDMxxVAL & SBxxVAL monitoring threshold=5V=D9h(UV)/DAh(OV). EVRMONFILT.SWDFI L=1

**Table 3-32 Supply Monitors (cont'd)**

Parameter	Symbol	Values			Unit	Note / Test Condition
		Min.	Typ.	Max.		
$V_{DDP3}$ secondary supply monitor accuracy after trimming <sup>5)</sup>	$V_{DDP3MON}$ CC	2.97	3.035	3.1	V	EVR33xxVAL monitoring threshold=3.035V=CBh (UV)/CCh(OV). EVRMONFILT.EVR33 FIL = 3.
		3.235	3.30	3.365	V	EVR33xxVAL monitoring threshold=3.3V=DDh(OV,UV). EVRMONFILT.EVR33 FIL = 3.
		3.5	3.565	3.63	V	EVR33xxVAL monitoring threshold=3.565V=EEh (UV)/EFh(OV). EVRMONFILT.EVR33 FIL = 3.
$V_{DD}$ & $V_{DDPD}$ secondary supply monitor accuracy after trimming <sup>5)</sup>	$V_{DDMON}$ CC	1.125	1.15	1.175	V	EVRCxxVAL & PRExxVAL monitoring threshold=1.15V=C7h (UV)/C8h(OV). EVRMONFILT.EVRCFIL = 1.
		1.225	1.25	1.275	V	EVRCxxVAL & PRExxVAL monitoring threshold=1.25V=D9h(OV,UV). EVRMONFILT.EVRCFIL = 1.
		1.325	1.35	1.375	V	EVRCxxVAL & PRExxVAL monitoring threshold=1.35V=EAh (UV)/EBh(OV). EVRMONFILT.EVRCFIL = 1.
$V_{EXT}$ LVD Primary undervoltage reset Monitor threshold	$V_{LVDRST5}$ CC	2.3	-	2.72	V	Power-down
		2.4	-	2.75	V	Power-up
$V_{EVRSB}$ LVD Primary undervoltage reset Monitor threshold	$V_{LVDRSTSB}$ CC	2.18	-	2.47	V	Power-down
		2.21	-	2.5	V	Power-up
$V_{EXT}$ and $V_{EVRSB}$ PBIST primary overvoltage Monitor threshold	$V_{PBIST5}$ CC	5.63	-	-	V	

**Table 3-32 Supply Monitors (cont'd)**

Parameter	Symbol	Values			Unit	Note / Test Condition
		Min.	Typ.	Max.		
Primary undervoltage reset threshold for $V_{EXT}$ before trimming	$V_{RST5}$ CC	-	-	3.0	V	by last cold PORST release on supply ramp-up including voltage hysteresis.
EVR secondary monitor measurement latency for all 6 supply rails	$t_{MON}$ CC	-	-	3.2	$\mu$ s	HPOSC and SHPBG bandgap trimmed. Filter inactive.

- 1) The reset release on supply ramp-up is delayed by a time duration 20-40  $\mu$ s after reaching undervoltage reset threshold and by a voltage hysteresis of 1.5% above the undervoltage reset limit. These mechanisms serve as hysteresis to avoid multiple consecutive cold PORST events during slow supply ramp-ups owing to voltage drop/current jumps when reset is released. The reset limit of 2,97V at pin is for the case with 3.3V generated internally from EVR33. In case the 3.3V supply is provided externally, the bondwire drop will cause a reset at a higher voltage of 3.0V at the VDDP3 pin.
- 2) The monitor tolerances constitute the inherent variation of the band gap and ADC over process, voltage and temperature operational ranges. The  $V_{xxPRIUV}$  parameters are device individually tested in production with +-1% tolerance about the  $V_{xxPRIUV}$  limits. All voltages are measured on pins.
- 3)  $VRST_{xx}$  parameters are relevant only for the first cold PORST release. Later the reset levels are trimmed by the Firmware and reflected as  $V_{xxPRIUV}$  parameters before device is used with full performance. The cold PORST is released with a voltage hysteresis on all the primary monitors to avoid consecutive PORST toggling behavior.
- 4) In case the application is using 3.3V single supply (Single Supply mode (e), i.e.  $V_{EXT}$  and VDDP3 are shorted together), it is recommended to use secondary supply monitoring on channel VDDP3, because of the better accuracy of parameter VDDP3MON.
- 5) To monitor voltage level not provided in conditions the values for OV and UV thresholds can be generated by a linear interpolation or extrapolation based on the given points.

**Table 3-33 Supply Ramp**

Parameter	Symbol	Values			Unit	Note / Test Condition
		Min.	Typ.	Max.		
External $V_{EXT}$ & $V_{EVRSB}$ supply ramp-up and ramp-down slope 1) 2) 3)	$dV_{EXT}/dt$ SR	8.3E-6	1	100	V/ms	
External $V_{DDP3}$ supply ramp-up and ramp-down slope <sup>1)3)</sup>	$dV_{DDP3}/dt$ SR	8.3E-6	1	100	V/ms	
External $V_{DD}$ supply ramp-up and ramp-down slope <sup>1)3)</sup>	$dV_{DD}/dt$ SR	8.3E-6	1	100	V/ms	
External $V_{DDM}$ supply ramp-up and ramp-down slope <sup>1)3)</sup>	$dV_{DDM}/dt$ SR	8.3E-6	1	100	V/ms	

- 1) The device is robust against residual voltage ramp-up starting between 0 - 2.97 V for  $V_{EXT}$ ,  $V_{EVRSB}$ , VDDP3 and VDDM and 0-1 V for VDD. A voltage ramp range between 0.5V/min upto 120V/ms is covered in robustness validation.
  - 2) Also valid in case EVR33 or EVRC is used. The generated voltage itself follows a soft ramp-up over the  $t_{STR}$  time to avoid overshoots.
  - 3) The slope is defined as the maximal tangential slope between 0% to 100% voltage level. Actual waveform may not represent the specification.
- Up to 1000000 power-cycles, matching the limits defined in the table 'Supply Ramp' are allowed for TC38x, without any restriction to reliability.

**Table 3-34 EVRC SMPS**

Parameter	Symbol	Values			Unit	Note / Test Condition
		Min.	Typ.	Max.		
Input $V_{EXT}$ Voltage range	$V_{IN}$ SR	2.97	-	5.5	V	Start-up $V_{EXT}$ voltage > 2.6 V
SMPS regulator output voltage range including load/line regulation and aging	$V_{DDDC}$ CC	1.125	-	1.375	V	$V_{EXT} \geq 2.97V$ ; $V_{EXT} \leq 5.5V$ ; $I_{DDDC} \geq 1mA$ ; $I_{DDDC} \leq 1.5A$ ; untrimmed
SMPS regulator static voltage output accuracy after trimming without dynamic load/line regulation.	$V_{DDDCCT}$ CC	1.225	1.25	1.275	V	$V_{EXT} \geq 2.97V$ ; $V_{EXT} \leq 5.5V$ ; $I_{DDDC} \geq 1mA$ ; $I_{DDDC} \leq 1.5A$
Programmable switching frequency	$f_{DCDC}$ SR	1.6	1.82	2.0	MHz	Start-up frequency switches from 500 KHz in open loop operation to 1.82 MHz in closed loop Operation.
		-	0.8	-	MHz	Start-up frequency switches from 500 KHz in open loop operation to 1.82 MHz in closed loop Operation. 0.8 MHz to be set in SW.
Startup time	$t_{STRDC}$ CC	-	-	900	$\mu s$	SMPS Start-up Mode. It is defined between $V_{EXTPRIUV}$ reset threshold till PORST release, on condition that all other PORST requirements were released before. $I_{START} < 700mA$ .
Switching frequency modulation spread	$\Delta f_{DCSPR}$ CC	-	1.8%	-	MHz	
Maximum ripple at $I_{MAX}$	$\Delta V_{DDDC}$ CC	-	-	16	mV	$V_{EXT} \geq 2.97V$ ; $V_{EXT} \leq 5.5V$ ; $I_{DDDC} \geq 300mA$ ; $I_{DDDC} \leq 1.5A$ ; $\Delta V_{DDDC} = (\text{Peak to Peak ripple} / 2)$
No load current consumption of SMPS regulator	$I_{DCNL}$ CC	-	15	19	mA	$f_{DCDC} = 1.82MHz$ ; $I_{DDDC} = I_{SLEEP}$ ; $V_{EXT} > 2.97 V$ ; $T_J = 25^\circ C$
		-	5	-	mA	LPM mode; $I_{DDDC} = I_{SLEEP}$ ; $V_{EXT} > 2.97 V$ ; $T_J = 25^\circ C$

**Table 3-34 EVRC SMPS (cont'd)**

Parameter	Symbol	Values			Unit	Note / Test Condition
		Min.	Typ.	Max.		
SMPS regulator load transient response	$dV_{DDDC} / dl_{OUT} CC$	-50	-	87	mV	$dI < -450mA$ ; $I_{DDDC}=500-1500mA$ ; $t_r=0.1\mu s$ ; $t_f=0.1\mu s$ ; $V_{DDDC}=1.25V$ ; $T_{settle}=100\mu s$
		-100	-	145	mV	$dI < -700mA$ ; $I_{DDDC}=750-1500mA$ ; $t_r=0.1\mu s$ ; $t_f=0.1\mu s$ ; $V_{DDDC}=1.25V$ ; $T_{settle}=100\mu s$
		-26	-	26	mV	$dI < 100mA$ ; $I_{DDDC}=50-1500mA$ ; $t_r=0.1\mu s$ ; $t_f=0.1\mu s$ ; $V_{DDDC}=1.25V$ ; $T_{settle}=20\mu s$ ;
Maximum output current	$I_{MAX} CC$	100	-	-	mA	LPM mode. Typical current in LPM Mode = $I_{SLEEP}$
		1.5	-	-	A	limited by thermal constraints and component choice
SMPS regulator line transient response	$dV_{DDDC} / dV_{IN} CC$	-75	-	75	mV	$dV/dT=120V/ms$ ; $dV < 2.97 - 5.5V$ ; $I_{DDDC}=50-1500mA$ ;
		-12.5	-	12.5	mV	$dV/dT=1V/ms$ ; $dV < 2.97 - 5.5V$ ; $I_{DDDC}=50-1500mA$ ;
SMPS regulator efficiency	$\eta_{DC} CC$	-	80	-	%	$V_{IN}=3.3V$ ; $I_{DDDC}=1500mA$ ; $f_{DCDC}=1.82MHz$
		-	75	-	%	$V_{IN}=5V$ ; $I_{DDDC}=1500mA$ ; $f_{DCDC}=1.82MHz$
Input Synchronisation frequency	$f_{DCDCSYNC} SR$	1.6	1.82	2.0	MHz	

**Table 3-35 EVRC SMPS External components**

Parameter	Symbol	Values			Unit	Note / Test Condition
		Min.	Typ.	Max.		
External output capacitor value <sup>1)</sup>	$C_{OUT} SR$	20.8	32	43.2	$\mu F$	$I_{DDDC}=1.5A$ ; $f_{DDDC} = 0.8MHz$
		15.4	22	29.7	$\mu F$	$I_{DDDC}=1.5A$ ; $f_{DDDC} = 1.82MHz$

**Table 3-35 EVRC SMPS External components (cont'd)**

Parameter	Symbol	Values			Unit	Note / Test Condition
		Min.	Typ.	Max.		
External output capacitor ESR	$C_{OUT\_ESR}$ SR	-	-	50	mOhm	$f \geq 0.5\text{MHz}$ ; $f \leq 10\text{MHz}$
		-	-	100	Ohm	$f = 10\text{Hz}$
External input capacitor value <sup>1)</sup>	$C_{IN}$ SR	6.5	10	13.5	$\mu\text{F}$	$I_{DDDC} = 1.5\text{A}$
External input capacitor ESR	$C_{IN\_ESR}$ SR	-	-	50	mOhm	$f \geq 0.5\text{MHz}$ ; $f \leq 10\text{MHz}$
		-	-	100	Ohm	$f = 100\text{Hz}$
External inductor value	$L_{DC}$ SR	3.29	4.7	6.11		$f_{DCDC} = 0.8\text{MHz}$
		2.31	3.3	4.29	$\mu\text{H}$	$f_{DCDC} = 1.82\text{MHz}$
External inductor DCR	$L_{DC\_DCR}$ SR	-	-	0.2	Ohm	
P + N-channel MOSFET logic level	$V_{LL}$ SR	-	-	2.5	V	
P + N-channel MOSFET drain source breakdown voltage	$ V_{BR\_DS} $ SR	+7	-	-	V	NMOS - $V_{GS} = 0$ .
		-	-	-7	V	PMOS - $V_{GS} = 0$ .
P + N-channel MOSFET drain source ON-state resistance	$R_{ON}$ SR	-	150	-	mOhm	$I_{DDDC} = 1.5\text{A}$ ; $ V_{GS}  = 2.5\text{V}$ ; $T_A = 25^\circ\text{C}$
P + N-channel MOSFET Gate Charge	$Q_G$ SR	-	-	8	nC	$I_{DDDC} = 1.5\text{A}$ ; NMOS- $ V_{GS}  = 5\text{V}$ ; 1.5A pulsed drain current
		-8	-	-	nC	$I_{DDDC} = 1.5\text{A}$ ; PMOS- $ V_{GS}  = 5\text{V}$ ; 1.5A pulsed drain current
External Inductor Saturation Current Margin	$\Delta I_{SAT}$ SR	400	-	-	mA	The saturation current of the coil must be larger than $I_{DDDC} + \Delta I_{SAT}$
P + N-channel MOSFET Gate threshold voltage	$V_{Gsth}$ SR	-	1	-	V	NMOS
		-	-1	-	V	PMOS
N-channel MOSFET reverse diode forward voltage	$V_{RDN}$ SR	-	0.8	-	V	

1) Capacitor min-max range represent typical +35% tolerance including DC bias effect. The trace resistance from the capacitor to the supply or ground rail should be limited to 25 mOhm.

### 3.16 System Phase Locked Loop (SYS\_PLL)

**Table 3-36 PLL System**

Parameter	Symbol	Values			Unit	Note / Test Condition
		Min.	Typ.	Max.		
DCO Input frequency range	$f_{REF}$ CC	10	-	40	MHz	
Modulation Amplitude	MA CC	0	-	2	%	
Peak Period jitter	DP CC	-200	-	200	ps	without modulation (PLL output frequency)
Peak Accumulated Jitter	$D_{PP}$ CC	-5	-	5	ns	without modulation
Total long term jitter	$J_{TOT}$ CC	-	-	11.5	ns	including modulation; MA 1.25%; $f_{REF}$ 20MHz
System frequency deviation	$f_{SYSD}$ CC	-	-	0.01	%	with active modulation
DCO frequency range	$f_{DCO}$ CC	400	-	800	MHz	
PLL lock-in time	$t_L$ CC	4	-	100	$\mu$ s	

Note: The specified PLL jitter values are valid if the capacitive load per pin does not exceed  $C_L = 20$  pF with the maximum driver and sharp edge.

Note: The maximum peak-to-peak noise on the power supply voltage, is limited to a peak-to-peak voltage of  $V_{PP} = 100$  mV for noise frequencies below 300 KHz and  $V_{PP} = 40$  mV for noise frequencies above 300 KHz. These conditions can be achieved by appropriate blocking of the supply voltage as near as possible to the supply pins and using PCB supply and ground planes.

### 3.17 Peripheral Phase Locked Loop (PER\_PLL)

**Table 3-37 PLL Peripheral**

Parameter	Symbol	Values			Unit	Note / Test Condition
		Min.	Typ.	Max.		
Peak Accumulated jitter at SYSCLK pin	$D_{PP}$ CC	-1000	-	1000	ps	Peak only
Peak accumulated jitter	$D_{PPI}$ CC	-700	-	700	ps	Peak only
RMS Accumulated jitter	$D_{RMS}$ CC	-100	-	100	ps	measured over 1 $\mu$ s; $f_{REF} = 20$ MHz and $f_{DCO} = 640$ MHz or $f_{REF} = 25$ MHz and $f_{DCO} = 800$ MHz
Peak Period jitter	$DP$ CC	-200	-	200	ps	$f_{DCO} = 640$ MHz or $f_{DCO} = 800$ MHz
Absolute RMS jitter (PLL out)	$J_{ABS10}$ CC	-125	-	125	ps	$f_{REF} = 10$ MHz; $f_{DCO} = 640$ MHz
Absolute RMS jitter (PLL out)	$J_{ABS20}$ CC	-85	-	85	ps	$f_{REF} = 20$ MHz; $f_{DCO} = 640$ MHz
Absolute RMS jitter (PLL out)	$J_{ABS25}$ CC	-85	-	85	ps	$f_{REF} = 25$ MHz; $f_{DCO} = 800$ MHz
DCO frequency range	$f_{DCO}$ CC	400	-	800	MHz	
DCO input frequency range	$f_{REF}$ CC	10	-	40	MHz	
PLL lock-in time	$t_L$ CC	4	-	100	$\mu$ s	

Note: The specified PLL jitter values are valid if the capacitive load per pin does not exceed  $C_L = 20$  pF with the maximum driver and sharp edge.

Note: The maximum peak-to-peak noise on the power supply voltage, is limited to a peak-to-peak voltage of  $V_{PP} = 100$  mV for noise frequencies below 300 KHz and  $V_{PP} = 40$  mV for noise frequencies above 300 KHz. These conditions can be achieved by appropriate blocking of the supply voltage as near as possible to the supply pins and using PCB supply and ground planes.

### 3.18 AC Specifications

All AC parameters are specified for the complete operating range defined in [Chapter 3.4](#) unless otherwise noted in column Note / Test Condition.

Unless otherwise noted in the figures the timings are defined with the following guidelines:

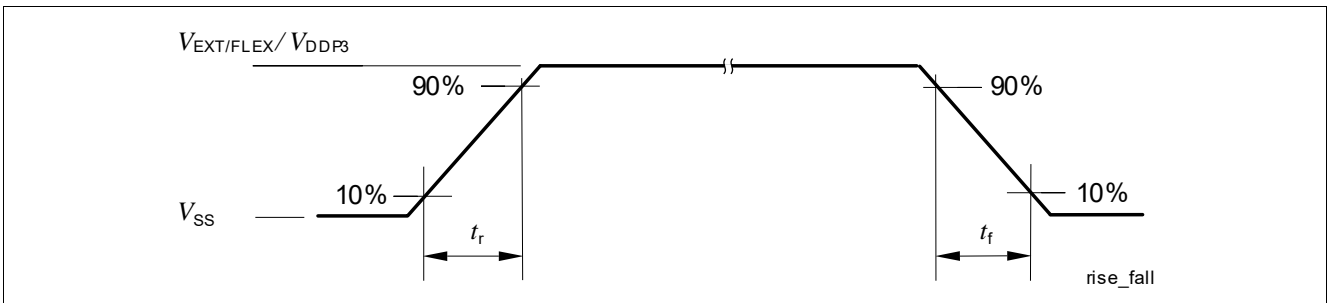

Figure 3-8 Definition of rise / fall times

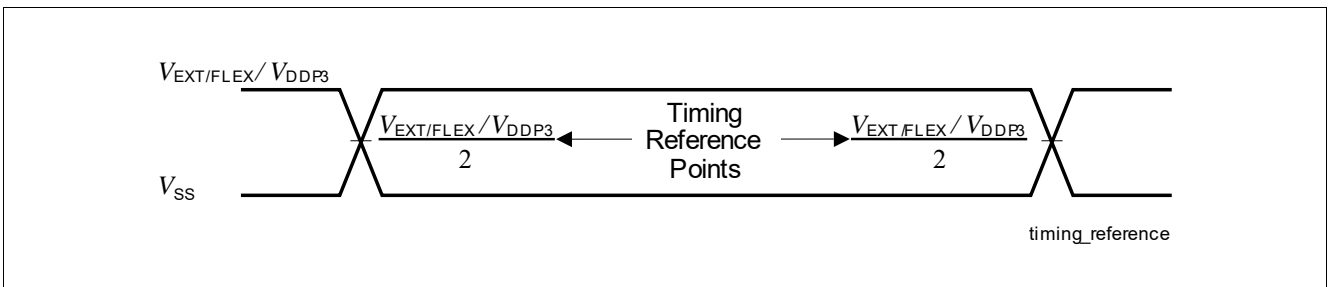

Figure 3-9 Time Reference Point Definition

### 3.19 JTAG Parameters

The following parameters are applicable for communication through the JTAG debug interface. The JTAG module is fully compliant with IEEE1149.1-2000.

**Table 3-38 JTAG**

Parameter	Symbol	Values			Unit	Note / Test Condition
		Min.	Typ.	Max.		
TCK clock period	$t_1$ SR	50	-	-	ns	
TCK high time	$t_2$ SR	10	-	-	ns	
TCK low time	$t_3$ SR	10	-	-	ns	
TCK clock rise time	$t_4$ SR	-	-	4	ns	
TCK clock fall time	$t_5$ SR	-	-	4	ns	
TDI/TMS setup to TCK rising edge	$t_6$ SR	6.0	-	-	ns	
TDI/TMS hold after TCK rising edge	$t_7$ SR	6.0	-	-	ns	
TDO valid after TCK falling edge (propagation delay)	$t_8$ CC	3.0	-	-	ns	$C_L \leq 20\text{pF}$
		-	-	25	ns	$C_L \leq 50\text{pF}$
TDO hold after TCK falling edge	$t_{18}$ CC	2	-	-	ns	
TDO high impedance to valid from TCK falling edge	$t_9$ CC	-	-	25	ns	$C_L \leq 50\text{pF}$
TDO valid output to high impedance from TCK falling edge	$t_{10}$ CC	-	-	25	ns	$C_L \leq 50\text{pF}$

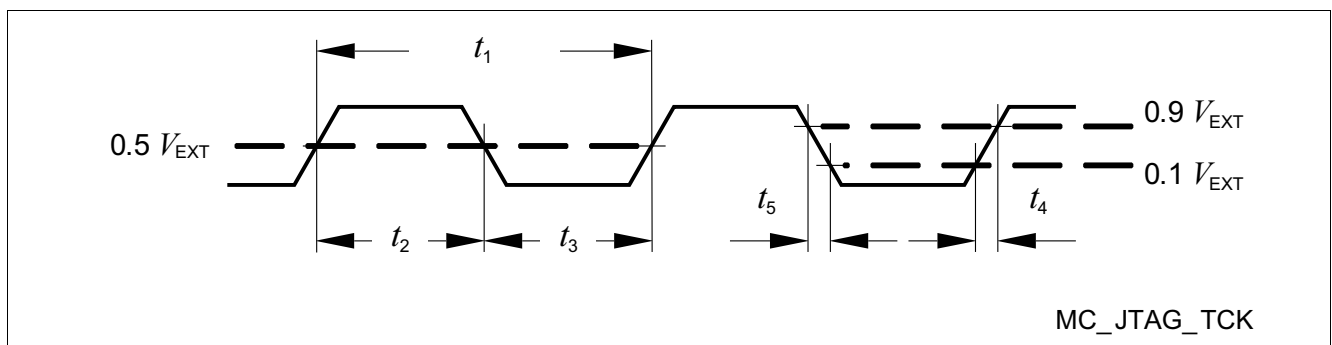

**Figure 3-10 Test Clock Timing (TCK)**

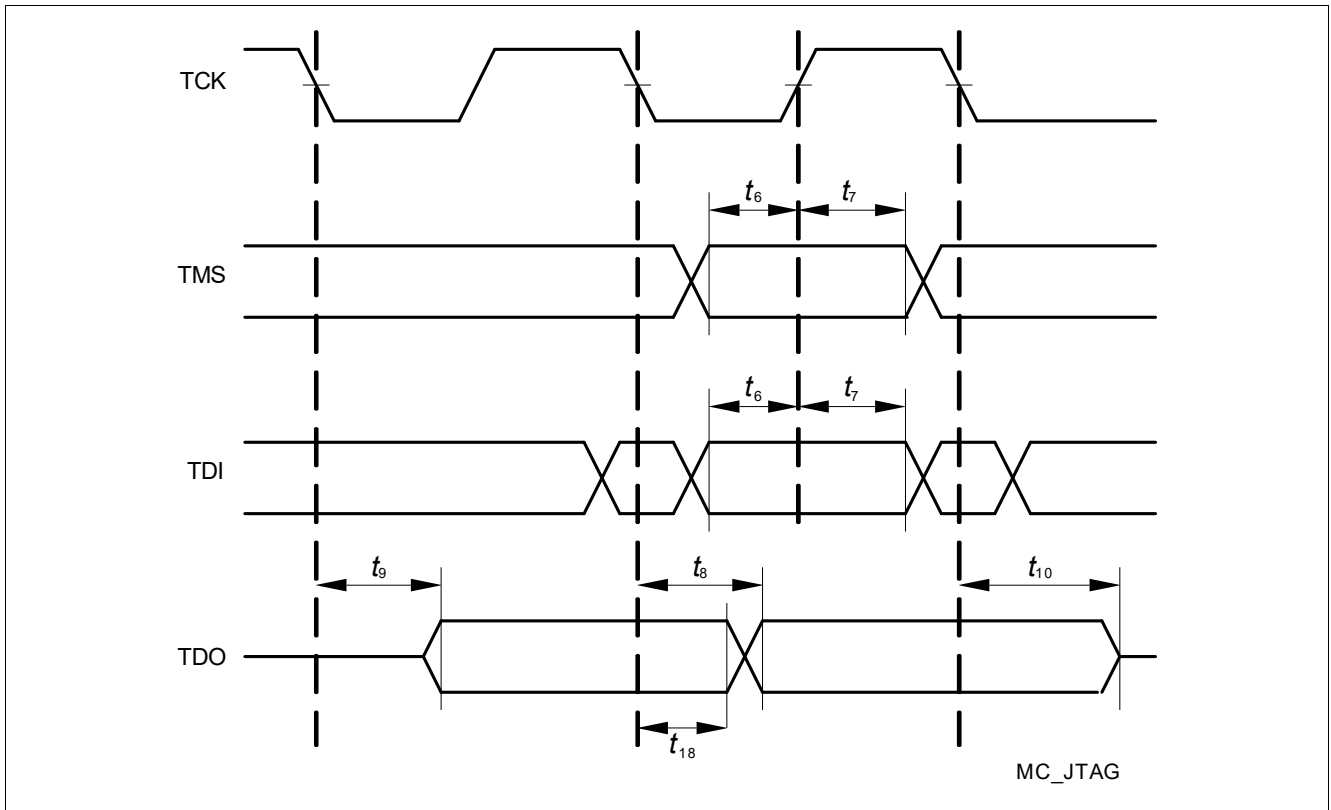

Figure 3-11 JTAG Timing

### 3.20 DAP Parameters

The following parameters are applicable for communication through the DAP debug interface.

**Table 3-39 DAP**

Parameter	Symbol	Values			Unit	Note / Test Condition
		Min.	Typ.	Max.		
DAP0 clock rise time	$t_{14}$ SR	-	-	1	ns	f=160MHz
		-	-	4	ns	f=40MHz
		-	-	2	ns	f=80MHz
DAP0 clock fall time	$t_{15}$ SR	-	-	1	ns	f=160MHz
		-	-	4	ns	f=40MHz
		-	-	2	ns	f=80MHz
DAP1 setup to DAP0 rising edge	$t_{16}$ SR	4	-	-	ns	
		5	-	-	ns	f=40MHz
DAP1 hold after DAP0 rising edge	$t_{17}$ SR	2	-	-	ns	
DAP1 valid per DAP0 clock period	$t_{19}$ CC	4	-	-	ns	$C_L=20\text{pF}$ ; f=160MHz
		8	-	-	ns	$C_L=20\text{pF}$ ; f=80MHz
		10	-	-	ns	$C_L=50\text{pF}$ ; f=40MHz
DAP0 high time	$t_{12}$ SR	2	-	-	ns	
DAP0 low time	$t_{13}$ SR	2	-	-	ns	
DAP0 clock period	$t_{11}$ SR	6.25	-	-	ns	

**Table 3-40 SCR DAP**

Parameter	Symbol	Values			Unit	Note / Test Condition
		Min.	Typ.	Max.		
DAP0 clock rise time	$t_{14}$ SR	-	-	8	ns	f=20MHz
DAP0 clock fall time	$t_{15}$ SR	-	-	8	ns	f=20MHz
DAP1 setup to DAP0 rising edge	$t_{16}$ SR	10	-	-	ns	
DAP1 hold after DAP0 rising edge	$t_{17}$ SR	10	-	-	ns	
DAP1 valid per DAP0 clock period	$t_{19}$ CC	30	-	-	ns	$C_L=20\text{pF}$ ; f=20MHz
DAP0 high time	$t_{12}$ SR	15	-	-	ns	
DAP0 low time	$t_{13}$ SR	15	-	-	ns	
DAP0 clock period	$t_{11}$ SR	50	-	-	ns	

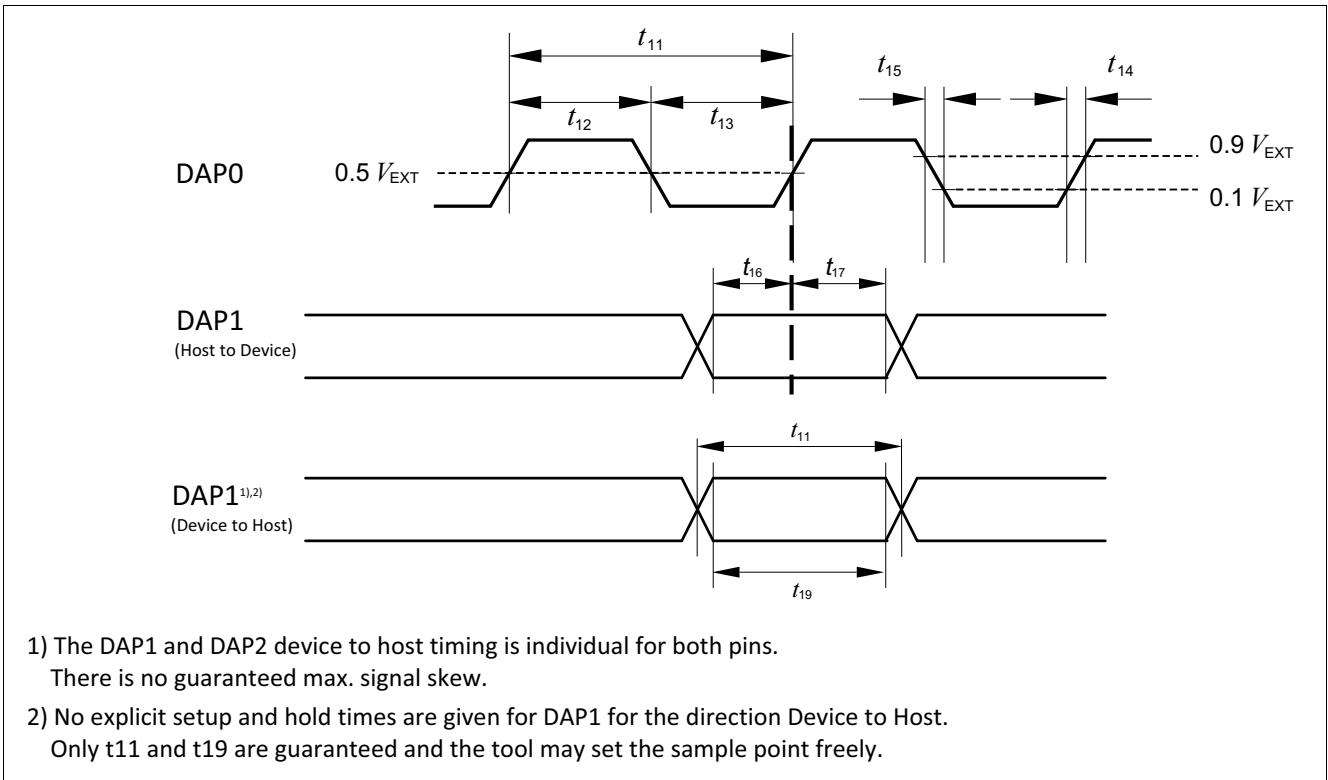

**Figure 3-12 DAP Timing**

*Note: The DAP1 and DAP2 device to host timing is individual for both pins. There is no guaranteed max. signal skew.*

### 3.21 ASCLIN SPI Master Timing

This section defines the timings for the ASCLIN in the TC38x.

*Note: Pad asymmetry is already included in the following timings.*

**Table 3-41 Master Mode strong sharp (ss) output pads**

Parameter	Symbol	Values			Unit	Note / Test Condition
		Min.	Typ.	Max.		
ASCLKO clock period	$t_{50}$ CC	20	-	-	ns	$C_L=25\text{pF}$
Deviation from ideal duty cycle	$t_{500}$ CC	-2	-	2	ns	$C_L=25\text{pF}$
MTSR delay from ASCLKO shifting edge	$t_{51}$ CC	-3.5	-	3.5	ns	$C_L=25\text{pF}$
ASLSON delay from the first ASCLKO edge	$t_{510}$ CC	-3	-	3.5	ns	$C_L=25\text{pF}$
MRST setup to ASCLKO latching edge	$t_{52}$ SR	25	-	-	ns	$C_L=25\text{pF}$
MRST hold from ASCLKO latching edge	$t_{53}$ SR	-2	-	-	ns	$C_L=25\text{pF}$

**Table 3-42 Master Mode strong medium (sm) output pads**

Parameter	Symbol	Values			Unit	Note / Test Condition
		Min.	Typ.	Max.		
ASCLKO clock period	$t_{50}$ CC	50	-	-	ns	$C_L=50\text{pF}$
Deviation from ideal duty cycle	$t_{500}$ CC	-5	-	5	ns	$C_L=50\text{pF}$
MTSR delay from ASCLKO shifting edge	$t_{51}$ CC	-7	-	7	ns	$C_L=50\text{pF}$
ASLSON delay from the first ASCLKO edge	$t_{510}$ CC	-7	-	7	ns	$C_L=50\text{pF}$
MRST setup to ASCLKO latching edge	$t_{52}$ SR	35	-	-	ns	$C_L=50\text{pF}$
MRST hold from ASCLKO latching edge	$t_{53}$ SR	-5	-	-	ns	$C_L=50\text{pF}$

**Table 3-43 Master Mode medium (m) output pads**

Parameter	Symbol	Values			Unit	Note / Test Condition
		Min.	Typ.	Max.		
ASCLKO clock period	$t_{50}$ CC	160	-	-	ns	$C_L=50\text{pF}$
Deviation from ideal duty cycle	$t_{500}$ CC	-10	-	10	ns	$C_L=50\text{pF}$
MTSR delay from ASCLKO shifting edge	$t_{51}$ CC	-20	-	20	ns	$C_L=50\text{pF}$
ASLSON delay from the first ASCLKO edge	$t_{510}$ CC	-20	-	20	ns	$C_L=50\text{pF}$

Electrical Specification ASCLIN SPI Master Timing

Table 3-43 Master Mode medium (m) output pads (cont'd)

Parameter	Symbol	Values			Unit	Note / Test Condition
		Min.	Typ.	Max.		
MRST setup to ASCLKO latching edge	$t_{52}$ SR	80	-	-	ns	$C_L=50pF$
MRST hold from ASCLKO latching edge	$t_{53}$ SR	-15	-	-	ns	$C_L=50pF$

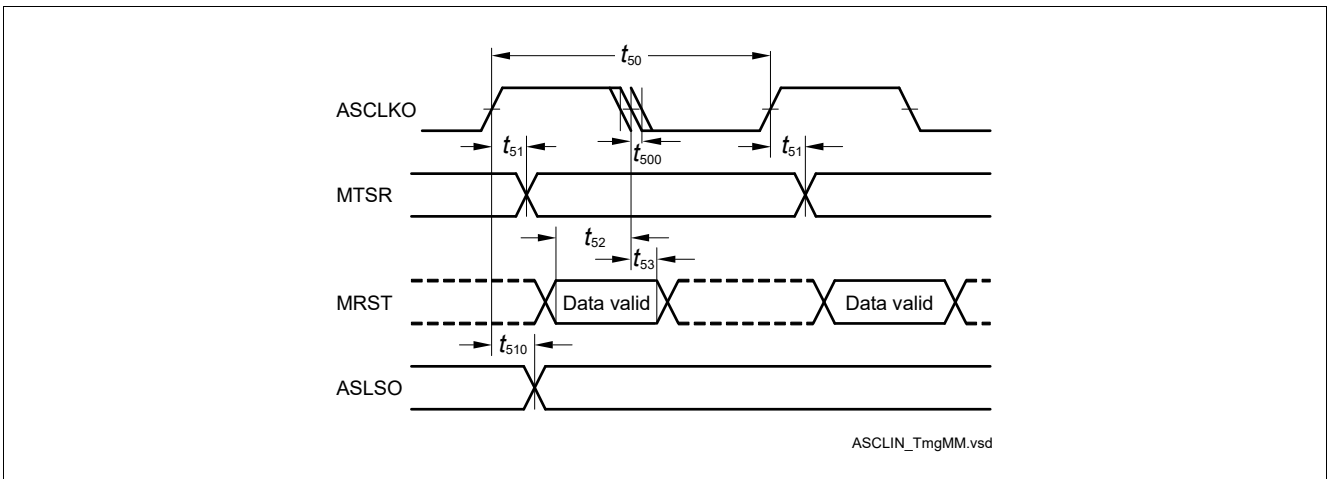

Figure 3-13 ASCLIN SPI Master Timing

### 3.22 QSPI Timings, Master and Slave Mode

This section defines the timings for the QSPI in the TC38x.

It is assumed that SCLKO, MTSR, and SLSO pads have the same pad settings:

*Note: Pad asymmetry is already included in the following timings.*

**Table 3-44 Master Mode Timing, LVDS output pads for data and clock**

Parameter	Symbol	Values			Unit	Note / Test Condition
		Min.	Typ.	Max.		
SCLKO clock period	$t_{50}$ CC	20 <sup>1)</sup>	-	-	ns	CL=25pF
Deviation from the ideal duty cycle	$t_{500}$ CC	-1 <sup>1)</sup>	-	1 <sup>1)</sup>	ns	CL=25pF
MTSR delay from SCLKO shifting edge	$t_{51}$ CC	-3 <sup>1)</sup>	-	4 <sup>1)</sup>	ns	CL=25pF
SLSOn deviation from the ideal programmed position	$t_{510}$ CC	-4 <sup>1)</sup>	-	5.5 <sup>1)</sup>	ns	$C_L=25pF$ , driver strength ss
		-10 <sup>1)</sup>	-	10 <sup>1)</sup>	ns	$C_L=25pF$ , driver strength sm
		-30 <sup>1)</sup>	-	30 <sup>1)</sup>	ns	$C_L=25pF$ , driver strength m
MRST setup to SCLK latching edge	$t_{52}$ SR	18 <sup>1)</sup>	-	-	ns	CL=25pF; valid for LVDS Input pads of QSPI2 only
		19.5 <sup>1)</sup>	-	-	ns	CL=25pF; valid for LVDS Input pads of QSPI4 only
MRST hold from SCLK latching edge	$t_{53}$ SR	-1 <sup>1)</sup>	-	-	ns	CL=25pF; valid for LVDS Input pads only

1) The load ( $C_L=25pF$ ) defined in the condition list is a load definition for the single end signal SLSO and does not intend to add an additional load inside the differential signal lines. For single end signals the load definition defines the max length of the signal on the PCB layout. For the LVDS pads the IEEE Std 1596.3-1996 load definitions apply.

**Table 3-45 Master Mode Strong Sharp (ss) output pads**

Parameter	Symbol	Values			Unit	Note / Test Condition
		Min.	Typ.	Max.		
SCLKO clock period	$t_{50}$ CC	50	-	-	ns	CL=25pF
Deviation from the ideal duty cycle	$t_{500}$ CC	-2	-	2	ns	CL=25pF
MTSR delay from SCLKO shifting edge	$t_{51}$ CC	-4	-	5	ns	CL=25pF
SLSOn deviation from the ideal programmed position	$t_{510}$ CC	-4	-	5	ns	CL=25pF
MRST setup to SCLK latching edge	$t_{52}$ SR	25 <sup>1) 2)</sup>	-	-	ns	CL=25pF
MRST hold from SCLK latching edge	$t_{53}$ SR	-2 <sup>1) 2)</sup>	-	-	ns	CL=25pF

**Electrical Specification QSPI Timings, Master and Slave Mode**

- 1) For compensation of the average on-chip delay the QSPI module provides the bit fields ECONz.A, B and C.
- 2) The setup and hold times are valid for both settings of the input pads thresholds: TTL and AL.

**Table 3-46 Master Mode Strong Medium (sm) output pads**

Parameter	Symbol	Values			Unit	Note / Test Condition
		Min.	Typ.	Max.		
SCLKO clock period	$t_{50}$ CC	50	-	-	ns	CL=50pF
Deviation from the ideal duty cycle	$t_{500}$ CC	-5	-	5	ns	CL=50pF
MTSR delay from SCLKO shifting edge	$t_{51}$ CC	-7	-	7	ns	CL=50pF
SLSON deviation from the ideal programmed position	$t_{510}$ CC	-7	-	7	ns	CL=50pF
MRST setup to SCLK latching edge	$t_{52}$ SR	35 <sup>1) 2)</sup>	-	-	ns	CL=50pF
MRST hold from SCLK latching edge	$t_{53}$ SR	-5 <sup>1)2)</sup>	-	-	ns	CL=50pF

- 1) For compensation of the average on-chip delay the QSPI module provides the bit fields ECONz.A, B and C.
- 2) The setup and hold times are valid for both settings of the input pads thresholds: TTL and AL.

**Table 3-47 Master Mode Medium (m) output pads**

Parameter	Symbol	Values			Unit	Note / Test Condition
		Min.	Typ.	Max.		
SCLKO clock period	$t_{50}$ CC	160	-	-	ns	CL=50pF
Deviation from the ideal duty cycle	$t_{500}$ CC	-10	-	10	ns	CL=50pF
MTSR delay from SCLKO shifting edge	$t_{51}$ CC	-20	-	20	ns	CL=50pF
SLSON deviation from the ideal programmed position	$t_{510}$ CC	-20	-	20	ns	CL=50pF
MRST setup to SCLK latching edge	$t_{52}$ SR	80 <sup>1) 2)</sup>	-	-	ns	CL=50pF
MRST hold from SCLK latching edge	$t_{53}$ SR	-15 <sup>1)2)</sup>	-	-	ns	CL=50pF
		-13 <sup>1)2)</sup>	-	-	ns	CL=50pF; SCR SSC

- 1) For compensation of the average on-chip delay the QSPI module provides the bit fields ECONz.A, B and C.
- 2) The setup and hold times are valid for both settings of the input pads thresholds: TTL and AL.

**Table 3-48 Slave mode timing**

Parameter	Symbol	Values			Unit	Note / Test Condition
		Min.	Typ.	Max.		
SCLK clock period	$t_{54}$ SR	$4 \times T_{MAX}$	-	-	ns	
SCLK duty cycle	$t_{55}/t_{54}$ SR	40	-	60	%	

Electrical Specification QSPI Timings, Master and Slave Mode

Table 3-48 Slave mode timing (cont'd)

Parameter	Symbol	Values			Unit	Note / Test Condition
		Min.	Typ.	Max.		
MTSR setup to SCLK latching edge	$t_{56}$ SR	6	-	-	ns	Input Level AL
		6	-	-	ns	Input Level TTL
MTSR hold from SCLK latching edge	$t_{57}$ SR	4	-	-	ns	Input Level AL
		6	-	-	ns	Input Level TTL
SLSI setup to first SCLK shift edge	$t_{58}$ SR	4	-	-	ns	Input Level AL
		6	-	-	ns	Input Level TTL
SLSI hold from last SCLK latching edge	$t_{59}$ SR	3	-	-	ns	Input Level AL
		6	-	-	ns	Input Level TTL
MRST delay from SCLK shift edge	$t_{60}$ CC	5	-	35	ns	driver = strong edge = medium ; $C_L=50pF$
		2	-	24	ns	driver = strong edge = sharp ; $C_L=50pF$
		15	-	80	ns	medium driver ; $C_L=50pF$
		14	-	-	ns	medium driver ; $C_L=50pF$ ; SCR SSC

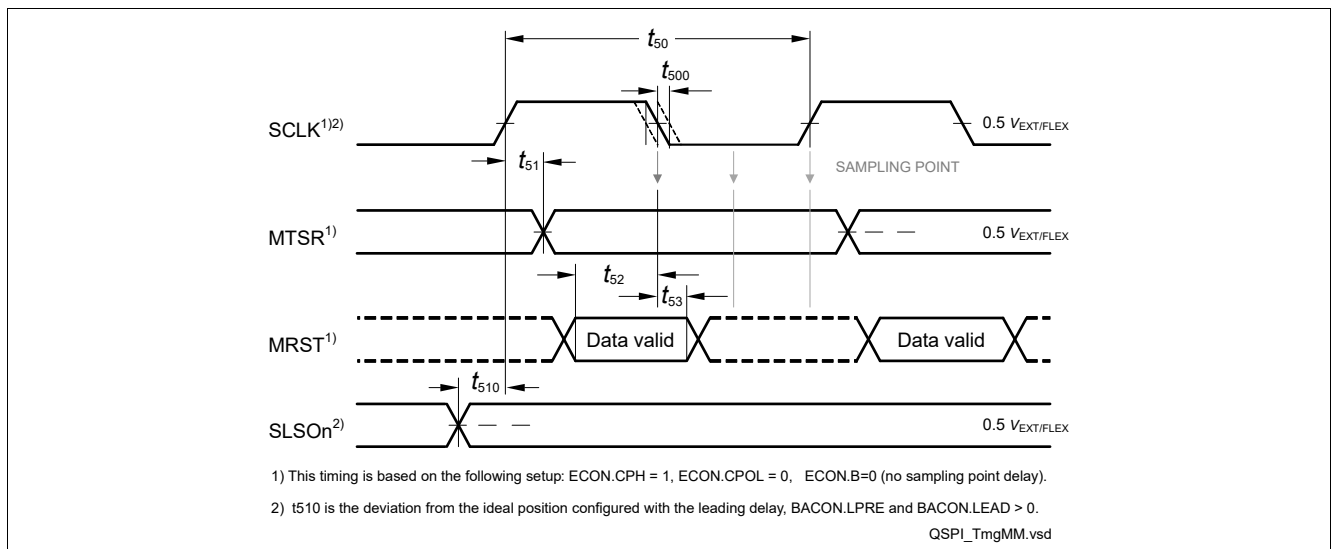

Figure 3-14 Master Mode Timing

Electrical Specification QSPI Timings, Master and Slave Mode

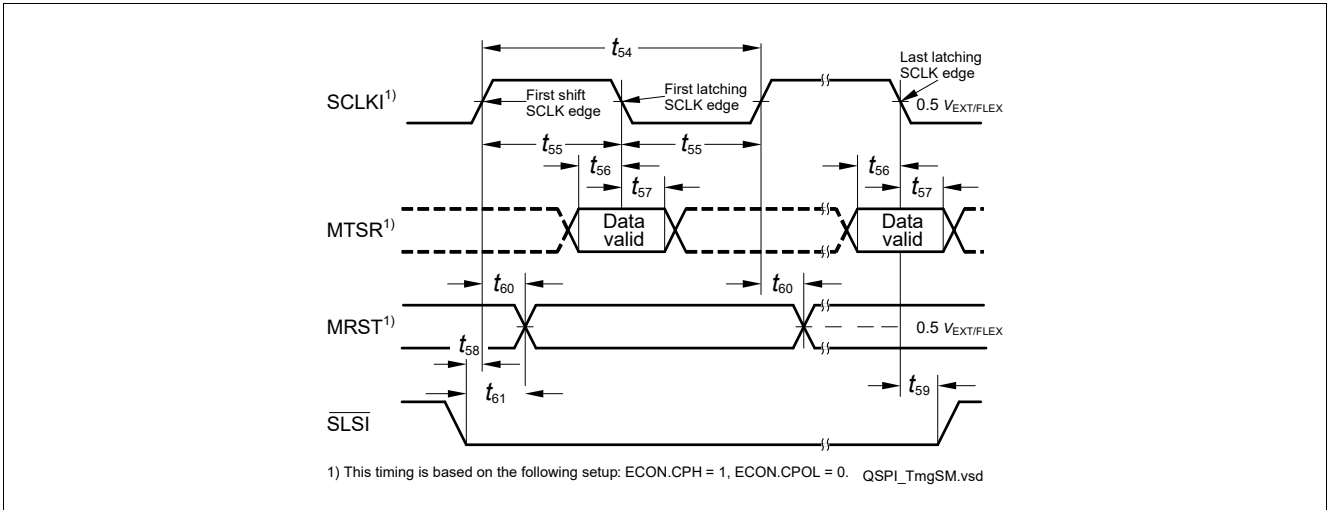

Figure 3-15 Slave Mode Timing

### 3.23 MSC Timing 5 V Operation

The following section defines the timings.

*Note: Pad asymmetry is already included in the following timings.*

*Note: Load for LVDS pads are defined as differential loads in the following timings.*

**Table 3-49 LVDS clock/data (LVDS pads in LVDS mode) valid for 5V**

Parameter	Symbol	Values			Unit	Note / Test Condition
		Min.	Typ.	Max.		
FCLPx clock period	$t_{40}$ CC	$2 * T_A$ <sup>1) 2) 3)</sup>	-	-	ns	LVDS; $C_L=50\text{pF}$
Deviation from ideal duty cycle	$t_{400}$ CC	-1 <sup>3)</sup>	-	1 <sup>3)</sup>	ns	LVDS; $0 < C_L < 50\text{pF}$
SOPx output delay	$t_{44}$ CC	-3 <sup>3)</sup>	-	3 <sup>3)</sup>	ns	$CL=50\text{pF}$
ENx output delay	$t_{45}$ CC	-4 <sup>3)</sup>	-	5 <sup>3)</sup>	ns	ss; $C_L=50\text{pF}$ ; ABRA block bypassed
		-4 <sup>3)</sup>	-	4 <sup>3)</sup>	ns	ss; $C_L=50\text{pF}$ ; ABRA block used
		-2 <sup>3)</sup>	-	10 <sup>3)</sup>	ns	sm; $C_L=50\text{pF}$
		-30 <sup>3)</sup>	-	30 <sup>3)</sup>	ns	m; $C_L=50\text{pF}$

1)  $T_A$  depends on the clock source selected for baud rate generation in the ABRA block of the MSC.

2) The capacitive load on the LVDS pins is differential, the capacitive load on the CMOS pins is single ended.

3) The load ( $C_L=50\text{pF}$ ) defined in the condition list is a load definition for the single end signal EN and does not intend to add an additional load inside the differential signal lines. For single end signals the load definition defines the max length of the signal on the PCB layout. For the LVDS pads the IEEE Std 1596.3-1996 load definitions apply.

**Table 3-50 Strong sharp (ss) driver for clock/data valid for 5V**

Parameter	Symbol	Values			Unit	Note / Test Condition
		Min.	Typ.	Max.		
FCLPx clock period	$t_{40}$ CC	$2 * T_A$	-	-	ns	$CL=50\text{pF}$
Deviation from ideal duty cycle	$t_{400}$ CC	-2	-	2	ns	$CL=50\text{pF}$
SOPx output delay	$t_{44}$ CC	-4	-	3.5	ns	$CL=50\text{pF}$
ENx output delay	$t_{45}$ CC	-4	-	3.5	ns	$CL=50\text{pF}$

**Table 3-51 Strong medium (sm) driver for clock/data valid for 5V**

Parameter	Symbol	Values			Unit	Note / Test Condition
		Min.	Typ.	Max.		
FCLPx clock period	$t_{40}$ CC	$2 * T_A$	-	-	ns	$CL=50\text{pF}$
Deviation from ideal duty cycle	$t_{400}$ CC	-5	-	5	ns	$CL=50\text{pF}$
SOPx output delay	$t_{44}$ CC	-7	-	7	ns	$CL=50\text{pF}$
ENx output delay	$t_{45}$ CC	-7	-	7	ns	$CL=50\text{pF}$

Electrical Specification MSC Timing 5 V Operation

Table 3-52 Medium (m) driver for clock/data valid for 5V

Parameter	Symbol	Values			Unit	Note / Test Condition
		Min.	Typ.	Max.		
FCLPx clock period	$t_{40}$ CC	$2 * T_A$	-	-	ns	CL=50pF
Deviation from ideal duty cycle	$t_{400}$ CC	-10	-	10	ns	CL=50pF
SOPx output delay	$t_{44}$ CC	-20	-	20	ns	CL=50pF
ENx output delay	$t_{45}$ CC	-20	-	20	ns	CL=50pF

Table 3-53 Upstream Interface

Parameter	Symbol	Values			Unit	Note / Test Condition
		Min.	Typ.	Max.		
SDI bit time	$t_{46}$ SR	$8 * t_{MSC}$	-	-	ns	
SDI rise time	$t_{48}$ SR	-	-	200	ns	
SDI fall time	$t_{49}$ SR	-	-	200	ns	

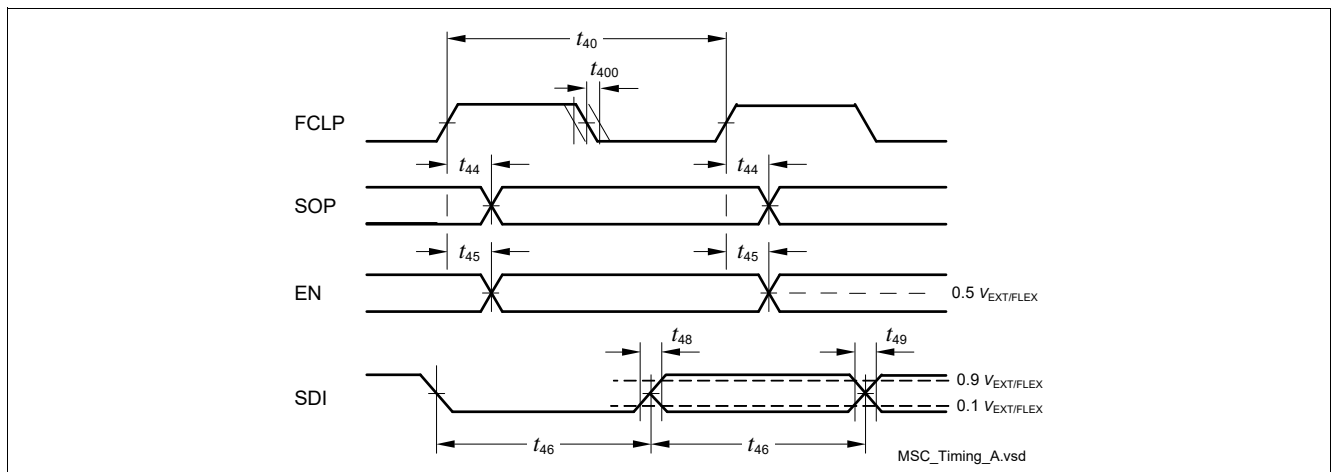

Figure 3-16 MSC Interface Timing

Note: The SOP data signal is sampled with the falling edge of FCLP in the target device.

### 3.24 Ethernet Interface (ETH) Characteristics

#### 3.24.1 ETH Measurement Reference Points

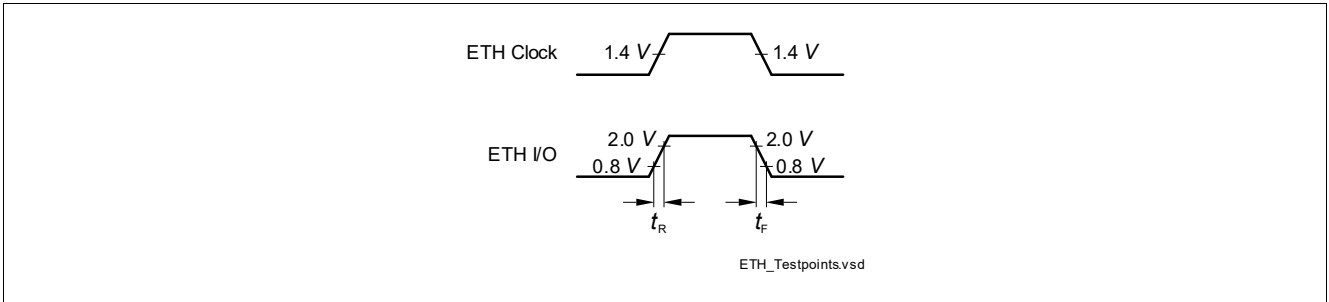

Figure 3-17 ETH Measurement Reference Points

3.24.2 ETH Management Signal Parameters (ETH\_MDC, ETH\_MDIO)

Table 3-54 ETH Management Signal Parameters valid for 3.3V

Parameter	Symbol	Values			Unit	Note / Test Condition
		Min.	Typ.	Max.		
ETH_MDC period	$t_1$ CC	400	-	-	ns	CL=25pF
ETH_MDC high time	$t_2$ CC	160	-	-	ns	CL=25pF
ETH_MDC low time	$t_3$ CC	160	-	-	ns	CL=25pF
ETH_MDIO setup time (output)	$t_4$ CC	10	-	-	ns	CL=25pF
ETH_MDIO hold time (output)	$t_5$ CC	10	-	-	ns	CL=25pF
ETH_MDIO data valid (input)	$t_6$ SR	0	-	300	ns	CL=25pF

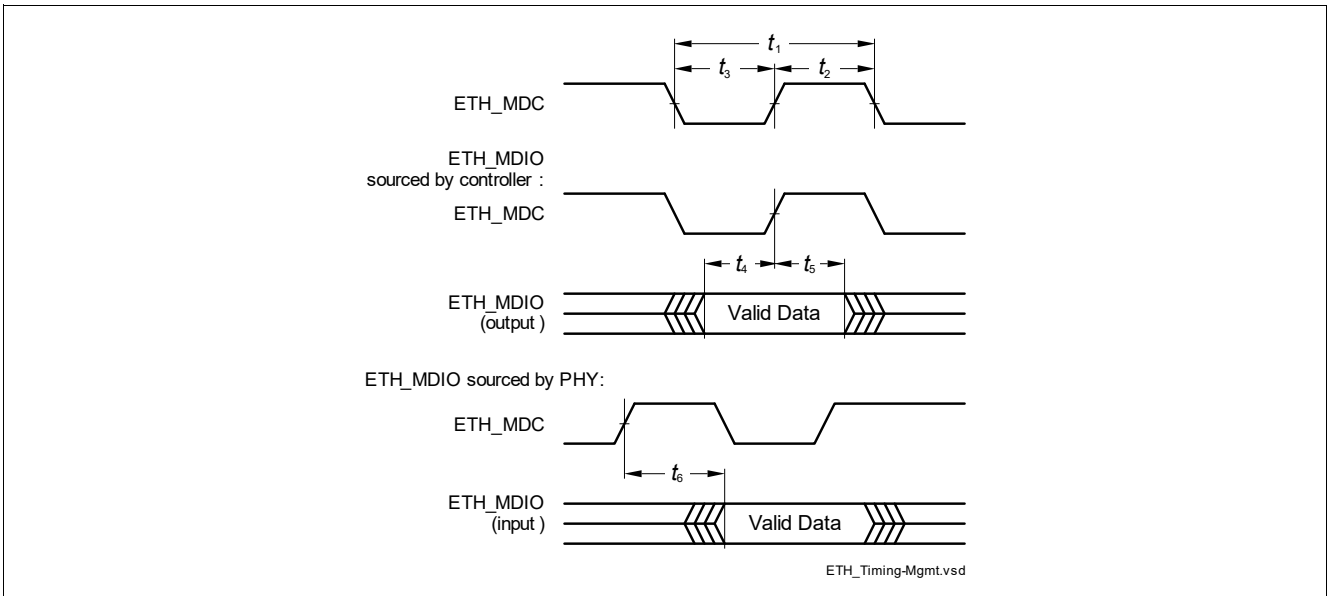

Figure 3-18 ETH Management Signal Timing

Electrical Specification Ethernet Interface (ETH) Characteristics

3.24.3 ETH MII Parameters

In the following, the parameters of the MII (Media Independent Interface) are described.

Table 3-55 ETH MII Signal Timing Parameters

Parameter	Symbol	Values			Unit	Note / Test Condition
		Min.	Typ.	Max.		
Clock period	$t_7$ SR	-	40	-	ns	CL=25pF ; baudrate=100Mbps
		-	400	-	ns	CL=25pF ; baudrate=10Mbps
Clock high time	$t_8$ SR	14	-	26	ns	CL=25pF ; baudrate=100Mbps
		140 <sup>1)</sup>	-	260 <sup>2)</sup>	ns	CL=25pF ; baudrate=10Mbps
Clock low time	$t_9$ SR	14	-	26	ns	CL=25pF ; baudrate=100Mbps
		140 <sup>1)</sup>	-	260 <sup>2)</sup>	ns	CL=25pF ; baudrate=10Mbps
Input setup time	$t_{10}$ SR	10	-	-	ns	CL=25pF
Input hold time	$t_{11}$ SR	10	-	-	ns	CL=25pF
Output valid time	$t_{12}$ CC	0	-	25	ns	CL=25pF

- 1) Defined by 35% of clock period.
- 2) Defined by 65% of clock period.

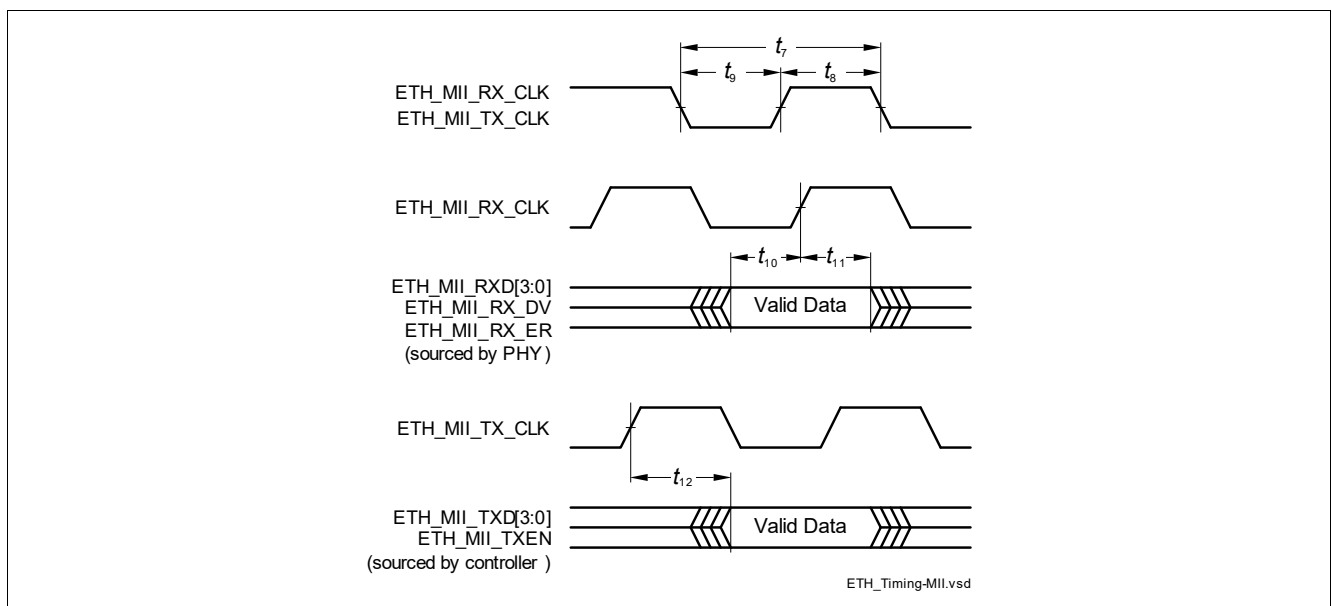

Figure 3-19 ETH MII Signal Timing

Electrical Specification Ethernet Interface (ETH) Characteristics

3.24.4 ETH RMII Parameters

In the following, the parameters of the RMII (Reduced Media Independent Interface) are described.

Table 3-56 ETH RMII Signal Timing Parameters valid for 3.3V

Parameter	Symbol	Values			Unit	Note / Test Condition
		Min.	Typ.	Max.		
ETH_RMII_REF_CL clock period	$t_{13}$ SR	-	20	-	ns	50ppm ; CL=25pF
ETH_RMII_REF_CL clock high time	$t_{14}$ SR	7 <sup>1)</sup>	-	13 <sup>2)</sup>	ns	CL=25pF
ETH_RMII_REF_CL clock low time	$t_{15}$ SR	7 <sup>1)</sup>	-	13 <sup>2)</sup>	ns	CL=25pF
ETHTXEN, ETHTXD[1:0], ETHRXD[1:0], ETHCRSDV; setup time <sup>3)</sup>	$t_{16}$ CC	4	-	-	ns	CL=25pF
ETHTXEN, ETHTXD[1:0], ETHRXD[1:0], ETHCRSDV; hold time <sup>3)</sup>	$t_{17}$ CC	2	-	-	ns	CL=25pF

- 1) Defined by 35% of clock period.
- 2) Defined by 65% of clock period.
- 3) For ETHRXD and ETHCRSDV signals this parameter is a SR.

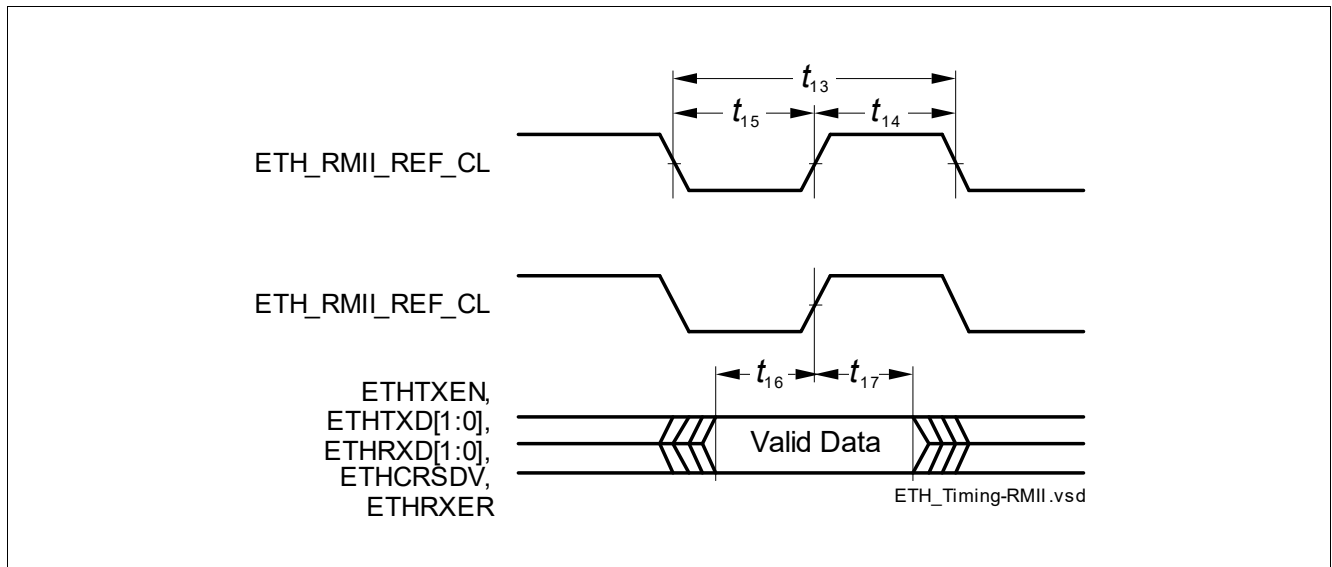

Figure 3-20 ETH RMII Signal Timing

Electrical Specification Ethernet Interface (ETH) Characteristics

3.24.5 ETH RGMII Parameters

In the following, the parameters of the RGMII are described.

Table 3-57 ETH RGMII Signal Timing Parameters valid for 3.3V

Parameter	Symbol	Values			Unit	Note / Test Condition
		Min.	Typ.	Max.		
TX Clock period	$t_{19}$ CC	36	40	44	ns	100Mbps
		360	400	440	ns	10Mbps
		7.2	8	8.8	ns	Gigabit
Data to Clock Output skew	$t_{20}$ CC	-500	0	500	ps	
Data to Clock input skew (at receiver)	$t_{21}$ SR	1	1.8	2.6	ns	SKEWCTL.RXCFG = 0; SKEWCTL.TXCFG = 0
Clock duty cycle	$t_{duty}$ CC	40	50	60	%	10/100Mbps
		45	50	55	%	Gigabit
GREFCLK duty cycle	$t_{duty\_in}$ SR	45	-	55	%	
GREFCLK Input accuracy	ACC SR	-0.005	-	0.005	%	

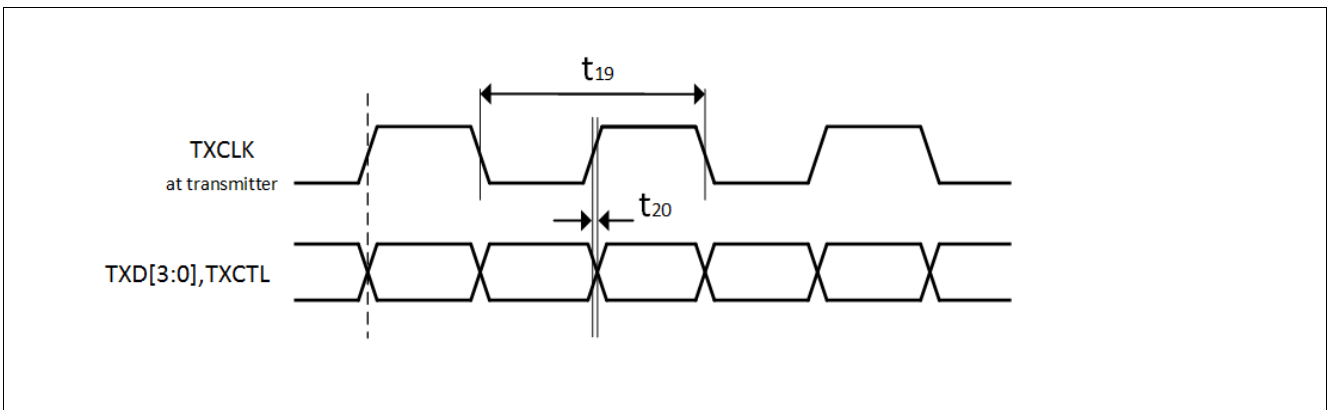

Figure 3-21 ETH RGMII TX Signal Timing (Delay on Destination (DoD))

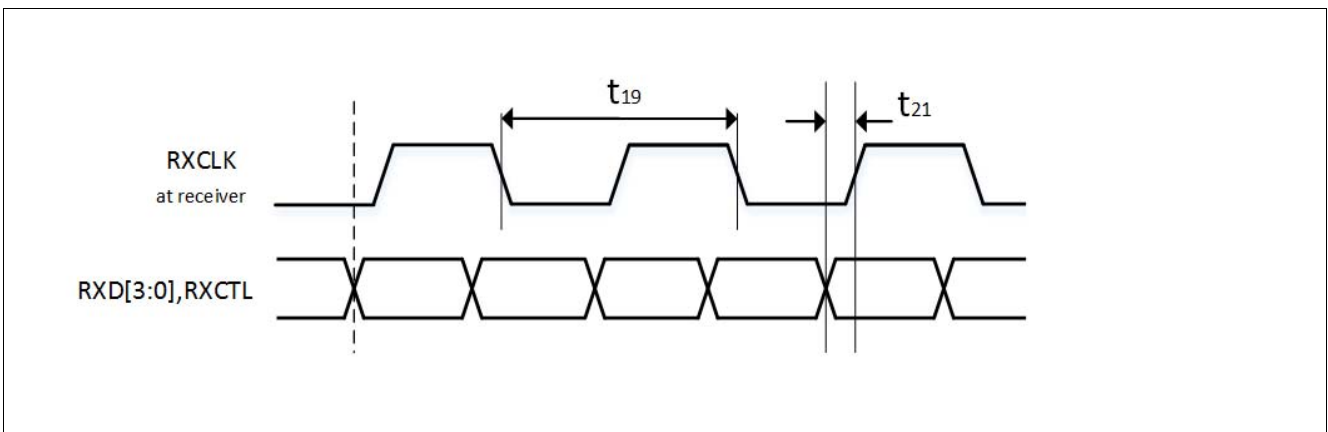

Figure 3-22 ETH RGMII RX Signal Timing (Delay on Source (DoS))

### 3.25 E-Ray Parameters

The timings of this section are valid for the strong driver and sharp edge settings of the output drivers with  $C_L = 25$  pF.

**Table 3-58 Transmit Parameters**

Parameter	Symbol	Values			Unit	Note / Test Condition
		Min.	Typ.	Max.		
Rise time of TxEN	$t_{dCCTxENRise25CC}$	-	-	9	ns	$C_L=25pF$
Fall time of TxEN	$t_{dCCTxENFall25CC}$	-	-	9	ns	$C_L=25pF$
Sum of rise and fall time	$t_{dCCTxRise25+dCCTxFall25CC}$	-	-	9	ns	20% - 80% ; $C_L=25pF$
Sum of delay between TP1_FF and TP1_CC and delays derived from TP1_FFi, rising edge of TxEN	$t_{dCCTxEN01CC}$	-	-	25	ns	
Sum of delay between TP1_FF and TP1_CC and delays derived from TP1_FFi, falling edge of TxEN	$t_{dCCTxEN10CC}$	-	-	25	ns	
Asymmetry of sending	$t_{tx\_asym}CC$	-2.45	-	2.45	ns	$C_L=25pF$
Sum of delay between TP1_FF and TP1_CC and delays derived from TP1_FFi, rising edge of TxD	$t_{dCCTxD01CC}$	-	-	25	ns	
Sum of delay between TP1_FF and TP1_CC and delays derived from TP1_FFi, falling edge of TxD	$t_{dCCTxD10CC}$	-	-	25	ns	
TxD signal sum of rise and fall time at TP1_BD	$t_{txd\_sum}CC$	-	-	9	ns	

**Table 3-59 Receive Parameters**

Parameter	Symbol	Values			Unit	Note / Test Condition
		Min.	Typ.	Max.		
Acceptance of asymmetry at receiving part	$t_{dCCTxAsymAccept25SR}$	-30.5	-	43.0	ns	$C_L=25pF$
Acceptance of asymmetry at receiving part	$t_{dCCTxAsymAccept15SR}$	-31.5	-	44.0	ns	$C_L=15pF$
Threshold for detecting logical high	$T_{uCCLogic1SR}$	35	-	70	%	
Threshold for detecting logical low	$T_{uCCLogic0SR}$	30	-	65	%	

Electrical Specification E-Ray Parameters

**Table 3-59 Receive Parameters** (cont'd)

Parameter	Symbol	Values			Unit	Note / Test Condition
		Min.	Typ.	Max.		
Sum of delay between TP4_CC and TP4_FF and delays derived from TP4_FFi, rising edge of RxD	$t_{dCCRxD01}$ CC	-	-	10	ns	
Sum of delay between TP4_CC and TP4_FF and delays derived from TP4_FFi, falling edge of RxD	$t_{dCCRxD10}$ CC	-	-	10	ns	

### 3.26 HSCT Parameters

**Table 3-60 HSCT - Rx parasitics and loads**

Parameter	Symbol	Values			Unit	Note / Test Condition
		Min.	Typ.	Max.		
Capacitance total budget	$C_{total}$ CC	-	3.5	5	pF	Total Budget for complete receiver including silicon, package, pins and bond wire
Parasitic inductance budget	$H_{total}$ CC	-	5	-	nH	

**Table 3-61 HSCT - Rx/Tx setup timing**

Parameter	Symbol	Values			Unit	Note / Test Condition
		Min.	Typ.	Max.		
RX o/p duty cycle	$DC_{rx}$ CC	40	-	60	%	
Disable time of the LVDS pad	$t_{LVDS_{DIS}}$ CC	-	-	20	ns	
Enable time of the LVDS pad	$t_{LVDS_{SEN}}$ CC	-	-	400	ns	
Wakeup time from Sleep Mode	$t_{SWU}$ CC	-	-	250	ns	
Maximum length of a wake-up glitch that does not wake-up the receiver	$t_{WUP}$ CC	-	-	0.2	ns	
Bias startup time	$t_{bias}$ CC	-	5	10	$\mu$ s	Bias distributor waking up from power down and provide stable Bias.
RX startup time	$t_{rx_i}$ CC	-	-	600	ns	Wake-up RX from power down.
TX startup time	$t_{tx}$ CC	-	-	280	ns	Wake-up TX from power down.

### 3.27 Inter-IC (I2C) Interface Timing

This section defines the timings for I2C in the TC38x.

All I2C timing parameter are SR for Master Mode and CC for Slave Mode.

**Table 3-62 I2C Standard Mode Timing**

Parameter	Symbol	Values			Unit	Note / Test Condition
		Min.	Typ.	Max.		
Fall time of both SDA and SCL	$t_1$	-	-	300	ns	Measured with a pull-up resistor of 4.7 kohms at each of the SCL and SDA line
Capacitive load for each bus line	$C_b$ SR	-	-	400	pF	
Bus free time between a STOP and ATART condition	$t_{10}$	4.7	-	-	μs	Measured with a pull-up resistor of 4.7 kohms at each of the SCL and SDA line
Rise time of both SDA and SCL	$t_2$	-	-	1000	ns	Measured with a pull-up resistor of 4.7 kohms at each of the SCL and SDA line
Data hold time	$t_3$	0	-	-	μs	Measured with a pull-up resistor of 4.7 kohms at each of the SCL and SDA line
Data set-up time	$t_4$	250	-	-	ns	Measured with a pull-up resistor of 4.7 kohms at each of the SCL and SDA line
Low period of SCL clock	$t_5$	4.7	-	-	μs	Measured with a pull-up resistor of 4.7 kohms at each of the SCL and SDA line
High period of SCL clock	$t_6$	4	-	-	μs	Measured with a pull-up resistor of 4.7 kohms at each of the SCL and SDA line
Hold time for the (repeated) START condition	$t_7$	4	-	-	μs	Measured with a pull-up resistor of 4.7 kohms at each of the SCL and SDA line

**Electrical Specification Inter-IC (I2C) Interface Timing**
**Table 3-62 I2C Standard Mode Timing (cont'd)**

Parameter	Symbol	Values			Unit	Note / Test Condition
		Min.	Typ.	Max.		
Set-up time for (repeated) START condition	$t_8$	4.7	-	-	μs	Measured with a pull-up resistor of 4.7 kohms at each of the SCL and SDA line
Set-up time for STOP condition	$t_9$	4	-	-	μs	Measured with a pull-up resistor of 4.7 kohms at each of the SCL and SDA line

**Table 3-63 I2C Fast Mode Timing**

Parameter	Symbol	Values			Unit	Note / Test Condition
		Min.	Typ.	Max.		
Fall time of both SDA and SCL	$t_1$	$20+0.1 \cdot C_b$	-	300	ns	Measured with a pull-up resistor of 4.7 kohms at each of the SCL and SDA line
Capacitive load for each bus line	$C_b$ SR	-	-	400	pF	
Bus free time between a STOP and ATART condition	$t_{10}$	1.3	-	-	μs	Measured with a pull-up resistor of 4.7 kohms at each of the SCL and SDA line
Rise time of both SDA and SCL	$t_2$	$20+0.1 \cdot C_b$	-	300	ns	Measured with a pull-up resistor of 4.7 kohms at each of the SCL and SDA line
Data hold time	$t_3$	0	-	-	μs	Measured with a pull-up resistor of 4.7 kohms at each of the SCL and SDA line
Data set-up time	$t_4$	100	-	-	ns	Measured with a pull-up resistor of 4.7 kohms at each of the SCL and SDA line
Low period of SCL clock	$t_5$	1.3	-	-	μs	Measured with a pull-up resistor of 4.7 kohms at each of the SCL and SDA line
High period of SCL clock	$t_6$	0.6	-	-	μs	Measured with a pull-up resistor of 4.7 kohms at each of the SCL and SDA line

**Electrical Specification Inter-IC (I2C) Interface Timing**
**Table 3-63 I2C Fast Mode Timing (cont'd)**

Parameter	Symbol	Values			Unit	Note / Test Condition
		Min.	Typ.	Max.		
Hold time for the (repeated) START condition	$t_7$	0.6	-	-	μs	Measured with a pull-up resistor of 4.7 kohms at each of the SCL and SDA line
Set-up time for (repeated) START condition	$t_8$	0.6	-	-	μs	Measured with a pull-up resistor of 4.7 kohms at each of the SCL and SDA line
Set-up time for STOP condition	$t_9$	0.6	-	-	μs	Measured with a pull-up resistor of 4.7 kohms at each of the SCL and SDA line

**Table 3-64 I2C High Speed Mode Timing**

Parameter	Symbol	Values			Unit	Note / Test Condition
		Min.	Typ.	Max.		
Capacitive load for each bus line	$C_b$ SR	-	-	400	pF	
Fall time of SCL	$t_{11}$	10 <sup>1)</sup>	-	40 <sup>1)</sup>	ns	bus line load of 100pF
Fall time of SDA	$t_{12}$	10 <sup>1)</sup>	-	80 <sup>1)</sup>	ns	bus line load of 100pF
Rise time of SCL	$t_{13}$	10 <sup>1)</sup>	-	40 <sup>1)</sup>	ns	bus line load of 100pF
Rise time of SDA	$t_{14}$	10 <sup>1)</sup>	-	80 <sup>1)</sup>	ns	bus line load of 100pF
Data hold time	$t_3$	0 <sup>1)</sup>	-	70 <sup>1)</sup>	ns	bus line load of 100pF
Data set-up time	$t_4$	10 <sup>1)</sup>	-	-	ns	bus line load of 100pF
Low period of SCL clock	$t_5$	160 <sup>1)</sup>	-	-	ns	bus line load of 100pF
High period of SCL clock	$t_6$	60 <sup>1)</sup>	-	-	ns	bus line load of 100pF
Hold time for the (repeated) START condition	$t_7$	160 <sup>1)</sup>	-	-	ns	bus line load of 100pF
Set-up time for (repeated) START condition	$t_8$	160 <sup>1)</sup>	-	-	ns	bus line load of 100pF
Set-up time for STOP condition	$t_9$	160 <sup>1)</sup>	-	-	ns	bus line load of 100pF

1) Values are defined for  $C_b = 100\text{pF}$ , for the Timing of  $C_b = 400\text{pF}$  see the I2C Standard.

Electrical Specification Inter-IC (I2C) Interface Timing

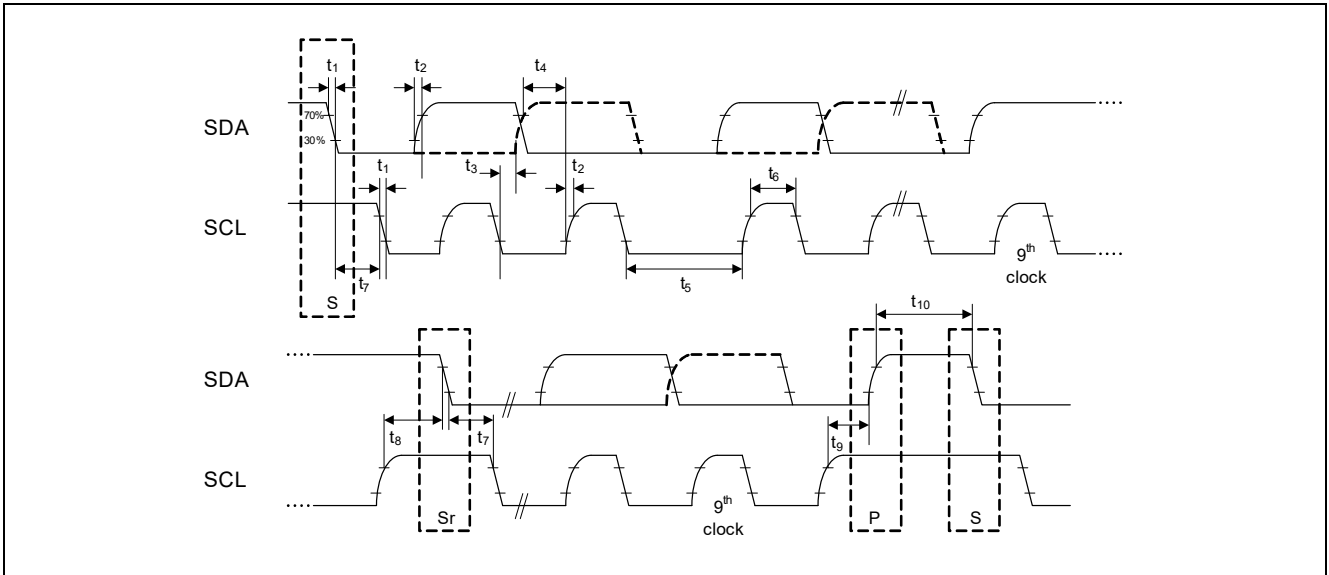

Figure 3-23 I2C Standard and Fast Mode Timing

### 3.28 FSP Parameters

Table 3-65 Safety

Parameter	Symbol	Values			Unit	Note / Test Condition
		Min.	Typ.	Max.		
Skew between FSP0 and FSP1	$t_{\text{FSPSKEW}}$ CC	-8	-	9	ns	$C_L=50\text{pF}$ , driver strength m
		-5	-	6	ns	$C_L=50\text{pF}$ , driver strength sm
		-4	-	5	ns	$C_L=50\text{pF}$ , driver strength ss

**3.29 Flash Target Parameters**
**Table 3-66 Flash**

Parameter	Symbol	Values			Unit	Note / Test Condition
		Min.	Typ.	Max.		
Program Flash Erase Time per logical sector <sup>1)</sup>	$t_{ERP}$ CC	-	-	0.5	s	cycle count < 1000
Program Flash Erase Time per Multi-Sector Command <sup>1)</sup>	$t_{MERP}$ CC	-	-	0.5	s	For consecutive logical sectors in a physical sector with total range ≤ 512 kByte; cycle count < 1000
Program Flash program time per page in 5 V mode <sup>1)</sup>	$t_{PRP5}$ CC	-	-	80	μs	32 Byte
Program Flash program time per page in 3.3 V mode <sup>1)</sup>	$t_{PRP3}$ CC	-	-	115	μs	32 Byte
Program Flash program time per burst in 5 V mode <sup>1)</sup>	$t_{PRPB5}$ CC	-	-	220	μs	256 Byte
Program Flash program time per burst in 3.3 V mode <sup>1)</sup>	$t_{PRPB3}$ CC	-	-	530	μs	256 Byte
Program Flash program time for 1 MByte with burst programming in 3.3 V mode excluding communication <sup>1)</sup>	$t_{PRPB3\_1MB}$ CC	-	-	2.2	s	Derived value for documentation purpose
Program Flash program time for 1 MByte with burst programming in 5 V mode excluding communication <sup>1)</sup>	$t_{PRPB5\_1MB}$ CC	-	-	1	s	Derived value for documentation purpose
Program Flash program time for complete PFlash with burst programming in 5 V mode excluding communication <sup>1)</sup>	$t_{PRPB5\_PF}$ CC	-	-	10	s	Derived value for documentation purpose
Write Page Once adder <sup>1)</sup>	$t_{ADD}$ CC	-	-	20	μs	Adder to Program Time when using Write Page Once
Program Flash suspend to read latency <sup>1)</sup>	$t_{SPNDP}$ CC	-	-	120	μs	For Write Burst, Verify Erased and for multi-(logical) sector erase commands
Data Flash Erase Disturb Limit (single ended sensing mode)	$N_{DFD}$ CC	-	-	50	cycles	
Data Flash Erase Disturb Limit (complement sensing mode)	$N_{DFDC}$ CC	-	-	500	cycles	
UCB Erase Disturb Limit	$N_{UCBD}$ CC	-	-	500	cycles	

**Electrical Specification Flash Target Parameters**
**Table 3-66 Flash (cont'd)**

Parameter	Symbol	Values			Unit	Note / Test Condition
		Min.	Typ.	Max.		
Program time data flash per page <sup>1)2)</sup>	$t_{PRD}$ CC	-	-	75	$\mu$ s	8 Byte
Complete Device Flash Erase Time PFlash and DFlash <sup>1)3) 4) 5)</sup>	$t_{ER\_Dev}$ CC	-	6.7	11.5	s	Valid for less than 1000 cycles, w/o UCB. Derived value for documentation purpose.
Data Flash program time per burst <sup>1)2)</sup>	$t_{PRDB}$ CC	-	-	140	$\mu$ s	32 Byte
Data Flash suspend to read latency <sup>1)</sup>	$t_{SPNDD}$ CC	-	-	120	$\mu$ s	
Wait time after margin change	$t_{FL\_MarginDel}$ CC	-	-	2	$\mu$ s	
Program Flash Endurance per Logical Sector	$N_{E\_P}$ CC	-	-	1000	cycles	Replace logical sector command shall be used if a sector fails during erase or program
Number of erase operations per physical sector in program flash	$N_{ERP}$ CC	-	-	16000	cycles	
Program Flash Retention Time, Sector	$t_{RET}$ CC	20	-	-	years	Max. 1000 erase/program cycles
UCB Retention Time	$t_{RTU}$ CC	20	-	-	years	Max. 100 erase/program cycles per UCB, max 500 erase/program cycles for all UCBs together
Data Flash access delay	$t_{DF}$ CC	-	-	100	ns	see RFLASH of DMU register HF_DWAIT
Data Flash ECC Delay	$t_{DFECC}$ CC	-	-	20	ns	see RECC of DMU register HF_DWAIT
Program Flash access delay	$t_{PF}$ CC	-	-	30	ns	see RFLASH of DMU register HF_PWAIT
Program Flash ECC delay	$t_{PFECC}$ CC	-	-	10	ns	see RECC and CECC of DMU register HF_PWAIT
Number of erase operations on DF0 over lifetime (complement sensing mode) <sup>6)</sup>	$N_{ERD0C}$ CC	-	-	4000000	cycles	
Number of erase operations on DF0 over lifetime (single ended sensing mode) <sup>7)</sup>	$N_{ERD0S}$ CC	-	-	750000	cycles	

**Electrical Specification Flash Target Parameters**
**Table 3-66 Flash (cont'd)**

Parameter	Symbol	Values			Unit	Note / Test Condition
		Min.	Typ.	Max.		
Number of erase operations on DF1 over lifetime (complement sensing mode) <sup>6)</sup>	$N_{ERD1C}$ CC	-	-	2000000	cycles	
Number of erase operations on DF1 over lifetime (single ended sensing mode) <sup>7)</sup>	$N_{ERD1S}$ CC	-	-	500000	cycles	
Data Flash Endurance per EEPROMx sector (complement sensing mode) <sup>8)</sup>	$N_{E\_EEP10C}$ CC	-	-	500000	cycles	Max. data retention time 10 years
DataFlash Endurance per EEPROMx sector (single ended sensing mode) <sup>8)</sup>	$N_{E\_EEP10S}$ CC	-	-	125000	cycles	Retention time and Tj according below example temperature profile
		-	-	125000	cycles	max data retention time 20y, Tj=110°C
		-	-	125000	cycles	max data retention time 8.2y, Tj=125°C
Data Flash Endurance per HSMx sector (complement sensing mode) <sup>8)</sup>	$N_{E\_HSMC}$ CC	-	-	250000	cycles	Max. data retention time 10 years
Data Flash Endurance per HSMx sector (single ended sensing mode) <sup>8)</sup>	$N_{E\_HSMS}$ CC	-	-	125000	cycles	Retention time and Tj according below example temperature profile
		-	-	125000	cycles	max data retention time 20y, Tj=110°C
		-	-	125000	cycles	max data retention time 8.2y, Tj=125°C
Junction temperature limit for PFlash program/erase operations	$T_{JPFlash}$ SR	-	-	150	°C	
Data Flash Erase Time per Sector <sup>1)3)5)</sup>	$t_{ERD1}$ CC	-	-	0.5	s	Max. 1000 erase/program cycles
Data Flash Erase Time per Sector <sup>1)3)5)</sup>	$t_{ERDM}$ CC	-	-	1.5	s	Max allowed cycles, see NE_EEP10 and NE_HSM parameters
DataFlash Adder on Erase Time per 32kByte erase size when using complement sensing mode <sup>1)</sup>	$t_{ER\_ADDC32C}$ CC	-	-	50	ms	Adder per 32 kByte on erase time; applicable only when using complement mode

**Electrical Specification Flash Target Parameters**
**Table 3-66 Flash (cont'd)**

Parameter	Symbol	Values			Unit	Note / Test Condition
		Min.	Typ.	Max.		
Data Flash Erase Time per Multi-Sector Command <sup>1)3)5)</sup>	$t_{MERD1}$ CC	-	-	0.5	s	Max 1000 erase/program cycles; For consecutive logical sectors $\leq 256$ KBytes
Data Flash Erase Time per Multi-Sector Command <sup>1)3)5)</sup>	$t_{MERDM}$ CC	-	-	1.5	s	Max allowed cycles, see NE_EEP10x and NE_HSMx Parameters; For consecutive logical sectors $\leq 256$ kByte
Program Flash Access Delay at reduced VDDP3 voltage supply during cranking	$t_{PF\_low\_VDDP3}$ CC	-	-	60	ns	see register DMU_HF_PWAIT.CFLASH
Data Flash Erase Verify time per page (Complement Sensing) <sup>2)</sup>	$t_{VER\_PAGE\_DC}$ CC	-	-	10	$\mu$ s	Time per 8 Byte page for Verify Erased Page command
Data Flash Erase Verify time per page (Single Ended Sensing) <sup>1)</sup>	$t_{VER\_PAGE\_DS}$ CC	-	-	10	$\mu$ s	Time per 8 Byte page for Verify Erased Page command
Program Flash Erase Verify time per page <sup>1)</sup>	$t_{VER\_PAGE\_P}$ CC	-	-	10	$\mu$ s	Time per 32 Byte page for Verify Erased Page command
Data Flash Erase Verify time per sector (Complement Sensing) <sup>1)</sup>	$t_{VER\_SEC\_DC}$ CC	-	-	200	$\mu$ s	Time per 2 KB sector for Verify Erased Logical Sector Range command
Data Flash Erase Verify time per sector (Single Ended Sensing) <sup>1)</sup>	$t_{VER\_SEC\_DS}$ CC	-	-	360	$\mu$ s	Time per 4 KB sector for Verify Erased Logical Sector Range command
Program Flash Erase Verify time per sector <sup>1)</sup>	$t_{VER\_SEC\_P}$ CC	-	-	360	$\mu$ s	Time per 16KB sector for Verify Erased Logical Sector Range command
Data Flash Erase Verify time per wordline (Complement Sensing) <sup>1)</sup>	$t_{VER\_WL\_DC}$ CC	-	-	30	$\mu$ s	
Data Flash Erase Verify time per wordline (Single Ended Sensing) <sup>1)</sup>	$t_{VER\_WL\_DS}$ CC	-	-	50	$\mu$ s	
Program Flash Erase Verify time per wordline <sup>1)</sup>	$t_{VER\_WL\_P}$ CC	-	-	30	$\mu$ s	

1) Only valid for  $f_{FSI} = 100$ MHz.

2) Time is not dependent on program mode (5V or 3.3V).

---

**Electrical Specification Flash Target Parameters**

- 3) Under out-of-spec conditions (e.g. over-cycling) or in case of activation of WL oriented defects, the duration of erase processes may be increased by up to 50%.
- 4) Using 512 kByte / 256 kByte erase commands (PFlash / DFlash).
- 5) If the DataFlash is operated in Complement Sensing Mode the erase time is increased by  $\text{erase\_size} / 32\text{kByte} \times t_{\text{ER\_ADDC32C}}$
- 6) Allows segmentation of addressable memory into 8 logical sectors; round robin cycling must still be done to consider erase disturb limit  $N_{\text{DFD}}$ .
- 7) Allows segmentation of addressable memory into 6 logical sectors; round robin cycling must still be done to consider erase disturb limit  $N_{\text{DFD}}$ .
- 8) Only valid when a robust EEPROM emulation algorithm is used. For more details see the Users Manual.

### 3.30 Quality Declarations

**Table 3-67 Quality Parameters**

Parameter	Symbol	Values			Unit	Note / Test Condition
		Min.	Typ.	Max.		
Moisture Sensitivity Level	$MSL$ CC	-	-	3		Conforming to Jedec J-STD--020C for 240C
ESD susceptibility according to Charged Device Model (CDM)	$V_{CDM}$ SR	-	-	500 <sup>1)</sup>	V	for all other balls/pins; conforming to JESD22-C101-C
		-	-	750	V	for corner balls/pins; conforming to JESD22-C101-C
ESD susceptibility according to Human Body Model (HBM)	$V_{HBM}$ SR	-	-	2000 <sup>2)</sup>	V	Conforming to JESD22-A114-B
ESD susceptibility of the LVDS pins according to Human Body Model (HBM)	$V_{HBM1}$ SR	-	-	2000	V	
Operation Lifetime	$t_{OP}$ CC	-	-	24500	hour	see below temperature profile as an example

1) Pads of the AGBT interface are limited to a maximum value of 250V.

2) Pads of the AGBT interface are limited to a maximum value of 1000V.

#### Example Temperature Profile

The following temperature profile is an example. Operation Lifetime plus Inactive time defines a 20 years period. Application specific temperature profiles need to be aligned and approved by Infineon Technologies for the fulfillment of quality and reliability targets.

**Table 3-68 Example Operation Lifetime Temperature Profile**

$T_J =$	Duration [h]	Comment
$\leq 170^\circ\text{C}$	$\leq 30$	
$\leq 160^\circ\text{C}$	$\leq 120$	
$\leq 150^\circ\text{C}$	$\leq 220$	
$\leq 140^\circ\text{C}$	$\leq 350$	
$\leq 130^\circ\text{C}$	$\leq 780$	
$\leq 120^\circ\text{C}$	$\leq 1600$	
$\leq 110^\circ\text{C}$	$\leq 3000$	
$\leq 100^\circ\text{C}$	$\leq 7000$	
$\leq 90^\circ\text{C}$	$\leq 8000$	
$\leq 80^\circ\text{C}$	$\leq 2400$	
$\leq 70^\circ\text{C}$	$\leq 1000$	
	$\leq 24500$	total time

Table 3-69 Example Inactive Lifetime Temperature Profile

$T_J$ =	Duration [h]	Comment
$\leq 55^\circ\text{C}$	$\leq 150700$	

3.31 Package Outline

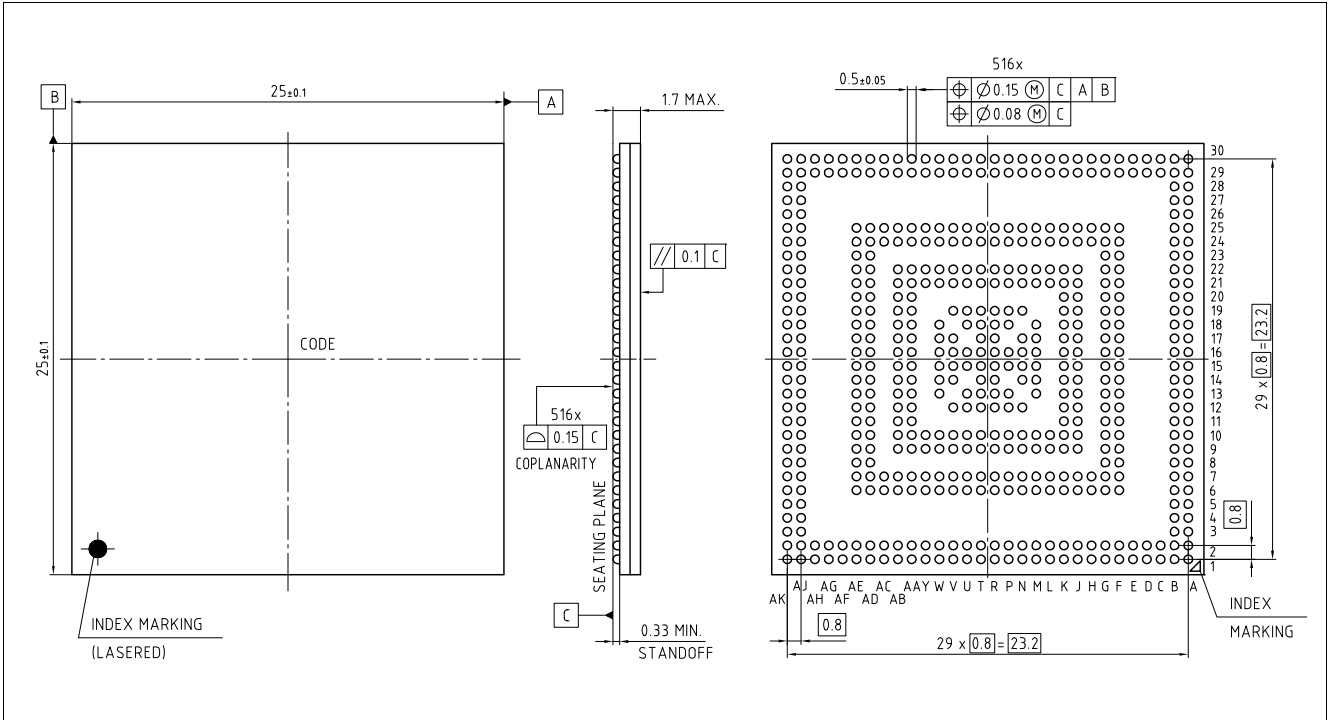

Figure 3-24 Package Outlines FBGA-516

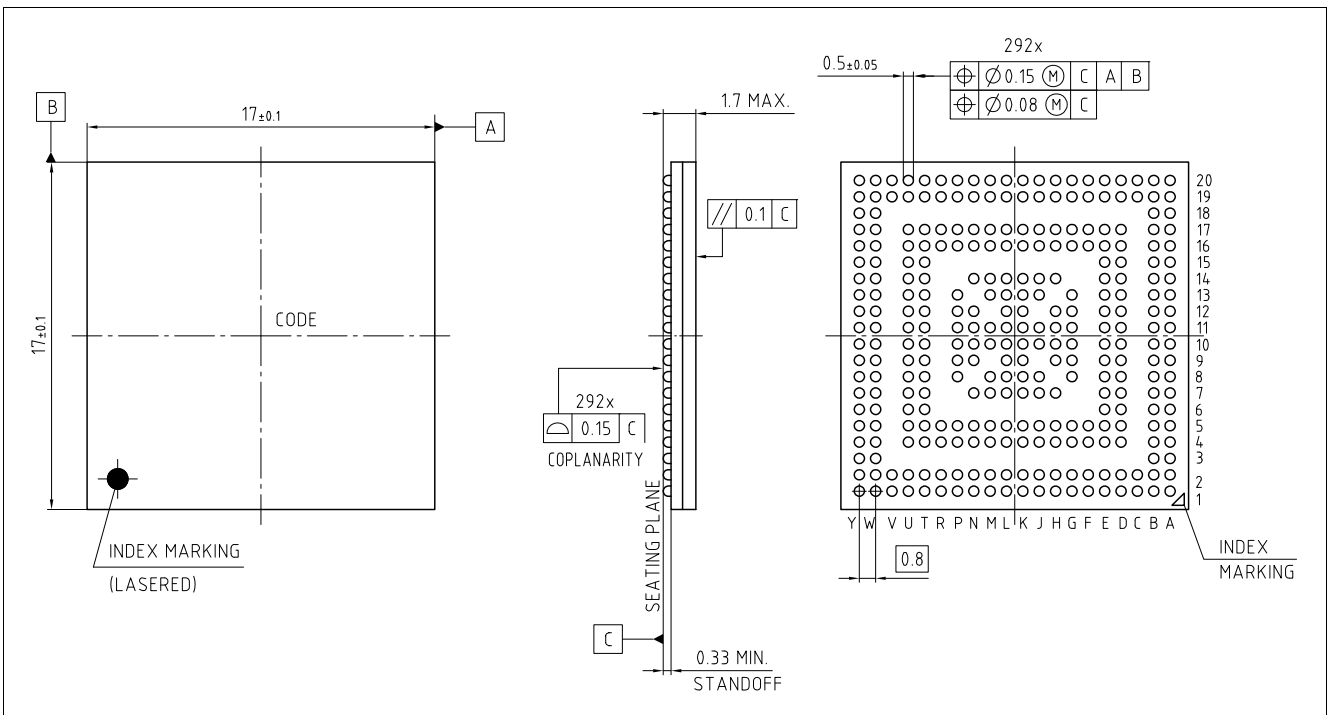

Figure 3-25 Package Outlines LFBGA-292

You can find all of our packages, sorts of packing and others in our Infineon Internet Page “Products”: <http://www.infineon.com/products>.

### 3.31.1 Package Parameters

**Table 3-70 Package Parameters**

Parameter	Symbol	Values			Unit	Note / Test Condition
		Min.	Typ.	Max.		
Thermal resistance (junction to ambient) <sup>1)</sup>	RTH_JA	-	-	14	K/W	FBGA516
	CC	-	-	17	K/W	LFBGA292
Thermal resistance (junction to case bottom) <sup>1)</sup>	RTH_JCB	-	-	3	K/W	FBGA516
	CC	-	-	4	K/W	LFBGA292
Thermal resistance (junction to case top) <sup>1)</sup>	RTH_JCT	-	-	5	K/W	FBGA516
	CC	-	-	5	K/W	LFBGA292

1) The top and bottom thermal resistances between the case and the ambient (RTH\_CTA, RTH\_CBA) are to be combined with the thermal resistances between the junction and the case given above (RTH\_JCT, RTH\_JCB), in order to calculate the total thermal resistance between the junction and the ambient (RTH\_JA). The thermal resistances between the case and the ambient (RTH\_CTA, RTH\_CBA) depend on the external system (PCB, case) characteristics and are under user responsibility. The junction temperature can be calculated using the following equation:  $T_J = T_A + RTH\_JA * P_D$ , where the RTH\_JA is the total thermal resistance between the junction and the ambient.

Thermal resistances as measured by the 'cold plate method' (MIL SPEC-883 Method 1012.1).

## 4 History

Version 0.4 is the first version of this document.

### 4.1 Changes from Version 0.4 to Version 0.6

- Update table Platform Feature Overview
- Changes in Pin Definition and Functions
  - Add pad type RFAST to Legend
  - Corrected ball assignant to NC and NC1
  - P32.0 replece name from EVR13 to EVRC
  - P32.1 replece name from EVR13 to EVRC
  - Add Function description for GTM\_TIM\_INxx Symbols
  - Change numbering for GTM\_TIM\_INxx Symbols
  - Update Function description for CAN signals
  - Add missing Function description for EVADC
  - Add missing Function description for EDSADC
  - Add Function description for GTM\_DTMxx Symbols
  - Update Function description for SCU\_E\_REQ signals
  - Change Symbol for SCU\_E\_REQ signals
  - Update Function description for SCU\_PD\_HWCFGx signals
  - remove PLL\_WRAPPER\_ANA\_0\_PAD\_SYSCCLK
  - Switch CBS\_TGyz from inverted to non inverted
  - Add CCUEXTCLK0
  - Add EDSADC\_EDS9NB to AN70
  - Add EDSADC\_EDS9NB to AN71
  - Add PMS\_DCDCSYNCO to P32.4
  - Add DAP3 to P21.6
  - Remove SDMMC\_DS from P15.2
  - ADD TDI to P21.6
  - Add DAPE1 to P21.6
  - Add DAP2 to P21.7
  - ADD TDO to P21.7
  - Remove DAP Function description from P21.7 Input
  - Add EVADC\_G5CH2 to AN50
  - Add EDSADC\_EDS9PB to AN70
  - Add EDSADC\_EDS9NB to AN71
- Changes in table 'Overload Parameters' of Overload
  - Change note of  $K_{OVDN}$  from "Overload injected on GPIO non LVDS pad and affecting neighbor slow pads;  $-2mA < I_{IN} < 0mA$ " to "Overload injected on GPIO non LVDS pad and affecting neighbor slow pads;  $-5mA < I_{IN} < 0mA$ "
  - Change max value of  $K_{OVDN}$  from ' $6 \cdot 10^{-4}$ ' to ' $1 \cdot 10^{-4}$ '
  - Change max value of  $K_{OVDN}$  from ' $1.7 \cdot 10^{-3}$ ' to ' $3 \cdot 10^{-4}$ '

## History Changes from Version 0.4 to Version 0.6

- Change note of  $K_{OV\text{DN}}$  from "Overload injected on LVDS pad and affecting neighbor LVDS pads" to "Overload injected on LVDS TX pad and affecting neighbor LVDS pads"
- Change max value of  $K_{OV\text{DN}}$  from '0.3' to '0.5'
- Change note of  $K_{OV\text{DP}}$  from 'Overload injected on LVDS pad and affecting neighbor LVDS pads' to 'Overload injected on LVDS TX pad and affecting neighbor LVDS pads'
- Change max value of  $K_{OV\text{DP}}$  from  $5 \cdot 10^{-4}$  to  $5 \cdot 10^{-3}$
- Change max value of  $K_{OV\text{DP}}$  from  $1 \cdot 10^{-5}$  to  $1.5 \cdot 10^{-3}$
- Change max value of  $K_{OV\text{AN}}$  from  $1 \cdot 10^{-4}$  to  $1 \cdot 10^{-5}$
- Change note of  $K_{OV\text{AN}}$  from 'Analog Inputs overlaid with class slow pads or pull down diagnostics;  $-1\text{mA} < I_{\text{IN}} < 0\text{mA}$ ' to 'Analog Inputs overlaid with class slow pads or pull down diagnostics;  $-5\text{mA} < I_{\text{IN}} < 0\text{mA}$ '
- Change max value of  $K_{OV\text{AN}}$  from  $1 \cdot 10^{-3}$  to  $1 \cdot 10^{-4}$
- Change note of  $K_{OV\text{AP}}$  from  $1 \cdot 10^{-5}$  to  $2 \cdot 10^{-5}$
- Change note of  $K_{OV\text{AP}}$  from  $1 \cdot 10^{-4}$  to  $2 \cdot 10^{-4}$
- Add parameter  $I_{\text{OUT}}$
- Operating Conditions
  - Change note of  $V_{\text{DDM}}$  from 'Lower voltage range' to "
  - Change note of  $V_{\text{EVRSB}}$  from ' $V_{\text{EVRSB}}$  is bonded together with  $V_{\text{EXT}}$  supply pin in smaller LQFP packages.' to "
- Changes in table 'Fast 5V GPIO' of Standard Pads
  - Change note of  $HYS$  from  $0.1 \cdot V_{\text{EXT/FLEX}}$  V' to  $0.09 \cdot V_{\text{EXT/FLEX}}$  V'
  - Change note of  $HYS$  from  $0.09 \cdot V_{\text{EXT/FLEX}}$  V' to  $0.075 \cdot V_{\text{EXT/FLEX}}$  V'
  - Change min value of  $R_{\text{DSON}}$  from 140 Ohm to 125 Ohm
  - Change typ value of  $R_{\text{DSON}}$  from 200 Ohm to 225 Ohm
  - Change note of  $R_{\text{DSON}}$  from '260 Ohm' to '320 Ohm'
  - Change note of  $R_{\text{DSON}}$  from '35 Ohm' to '31 Ohm'
  - Change note of  $R_{\text{DSON}}$  from '50 Ohm' to '55 Ohm'
  - Change note of  $R_{\text{DSON}}$  from '65 Ohm' to '80 Ohm'
  - Change note of  $t_{\text{RF}}$  from " $C_L = 25\text{pF}$ ; driver = strong sharp edge" to " $C_L = 25\text{pF}$ ; driver = strong sharp edge; from  $0.2 \cdot V_{\text{EXT/FLEX}}$  to  $0.8 \cdot V_{\text{EXT/FLEX}}$ "
  - Change note of  $t_{\text{RF}}$  from '2.8 ns' to '3.2 ns'
  - Change min value of  $t_{\text{RF}}$  from  $0.5 + 0.075 \cdot C_L$  ns to  $0.5 + 0.08 \cdot C_L$  ns
  - Change max value of  $t_{\text{RF}}$  from  $0.5 + 0.15 \cdot C_L$  ns to  $1.0 + 0.17 \cdot C_L$  ns
  - Change note of  $t_{\text{RF}}$  from ' $2.5 + 0.18 \cdot C_L$  ns' to ' $1.0 + 0.18 \cdot C_L$  ns'
  - Change note of  $t_{\text{RF}}$  from ' $2.5 + 0.35 \cdot C_L$  ns' to ' $5.0 + 0.35 \cdot C_L$  ns'
  - Change max value of  $t_{\text{RF}}$  from  $4 + 0.95 \cdot C_L$  ns to  $12 + 1.0 \cdot C_L$  ns
  - Change note of  $I_{\text{OZ}}$  from '-3900 nA' to '-5000 nA'
  - Change min value of  $I_{\text{OZ}}$  from -3600 nA to -5000 nA
  - Change min value of  $I_{\text{OZ}}$  from -6700 nA to -9000 nA
  - Change max value of  $I_{\text{OZ}}$  from 3900 nA to 5000 nA
  - Change max value of  $I_{\text{OZ}}$  from 3600 nA to 5000 nA
  - Change note of  $I_{\text{OZ}}$  from '6700 nA' to '9000 nA'
  - Change note of  $t_{\text{RF}}$  from ' $C_L = 25\text{pF}$ ; driver = strong sharp edge' to ' $C_L = 25\text{pF}$ ; driver = strong sharp edge; from  $0.2 \cdot V_{\text{EXT/FLEX}}$  to  $0.8 \cdot V_{\text{EXT/FLEX}}$ '

## History Changes from Version 0.4 to Version 0.6

- Change note of  $f_{IND}$  from " to 'AL and TTL'
- Change note of  $f_{OUTD}$  from " to 'medium driver'
- Change note of  $I_{PDL}$  from ' $V_{IL}$ ; AL or TTL' to ' $V_{IL}$ ; AL'
- Changes in table 'Fast 3.3V GPIO' of Standard Pads
  - Change note of  $HYS$  from ' $0.065 * V_{EXT/FLEX}$  V' to ' $0.055 * V_{EXT/FLEX}$  V'
  - Change min value of  $HYS$  from  $0.1 * V_{EXT/FLEX}$  V to  $0.09 * V_{EXT/FLEX}$  V
  - Change note of  $HYS$  from ' $0.07 * V_{EXT/FLEX}$  V' to ' $0.055 * V_{EXT/FLEX}$  V'
  - Change min value of  $R_{DSON}$  from 140 Ohm to 125 Ohm
  - Change note of  $R_{DSON}$  from '200 Ohm' to '225 Ohm'
  - Change note of  $R_{DSON}$  from '300 Ohm' to '320 Ohm'
  - Change note of  $R_{DSON}$  from '35 Ohm' to '31 Ohm'
  - Change typ value of  $R_{DSON}$  from 50 Ohm to 55 Ohm
  - Change max value of  $R_{DSON}$  from 77 Ohm to 80 Ohm
  - Change note of  $t_{RF}$  from " $C_L = 25\text{pF}$ ; driver = strong sharp edge" to " $C_L = 25\text{pF}$ ; driver = strong sharp edge; from  $0.2 * V_{EXT/FLEX}$  to  $0.8 * V_{EXT/FLEX}$ "
  - Change note of  $t_{RF}$  from '2 ns' to '1.6 ns'
  - Change min value of  $t_{RF}$  from  $4+0.57*C_L$  ns to  $2+0.57*C_L$  ns
  - Change max value of  $t_{RF}$  from  $0.75+0.15*C_L$  ns to  $2.5+0.21*C_L$  ns
  - Change max value of  $t_{RF}$  from  $1.5+0.38*C_L$  ns to  $8+0.4*C_L$  ns
  - Change note of  $t_{RF}$  from ' $7+1.1*C_L$  ns' to ' $10+1.25*C_L$  ns'
  - Change min value of  $I_{PUH}$  from |19|  $\mu\text{A}$  to |17|  $\mu\text{A}$
  - Change min value of  $I_{PUH}$  from |9|  $\mu\text{A}$  to |11|  $\mu\text{A}$
  - Change min value of  $I_{PDL}$  from |18|  $\mu\text{A}$  to |15|  $\mu\text{A}$
  - Change min value of  $I_{OZ}$  from -4100 nA to -5000 nA
  - Change min value of  $I_{OZ}$  from -3600 nA to -5000 nA
  - Change min value of  $I_{OZ}$  from -6700 nA to -9000 nA
  - Change max value of  $I_{OZ}$  from 4100 nA to 5000 nA
  - Change note of  $I_{OZ}$  from '3600 nA' to '5000 nA'
  - Change max value of  $I_{OZ}$  from 6700 nA to 9000 nA
  - Change note of  $t_{RF}$  from ' $C_L = 25\text{pF}$ ; driver = strong sharp edge' to ' $C_L = 25\text{pF}$ ; driver = strong sharp edge; from  $0.2 * V_{EXT/FLEX}$  to  $0.8 * V_{EXT/FLEX}$ '
  - Change note of  $f_{OUTD}$  from " to 'medium driver'
- Changes in table 'Slow 5V GPIO' of Standard Pads
  - Change min value of  $HYS$  from  $0.1 * V_{EXT/FLEX}$  V to  $0.09 * V_{EXT/FLEX}$  V
  - Change min value of  $HYS$  from  $0.09 * V_{EXT/FLEX}$  V to  $0.075 * V_{EXT/FLEX}$  V
  - Change min value of  $R_{DSON}$  from 140 Ohm to 125 Ohm
  - Change typ value of  $R_{DSON}$  from 200 Ohm to 225 Ohm
  - Change max value of  $R_{DSON}$  from 260 Ohm to 320 Ohm
  - Change note of  $t_{RF}$  from ' $4+0.95*C_L$  ns' to ' $12+1*C_L$  ns'
  - Change note of  $t_{RF}$  from ' $3.5+0.55*C_L$  ns' to ' $7+0.55*C_L$  ns'
  - Change note of  $I_{PUH}$  from ' $V_{IH}$ ; AL or TTL' to ' $V_{IH}$ ; AL or TTL; except VGATE1P and  $T_J > 150^\circ\text{C}$ '
  - Change note of  $I_{PUH}$  from ' $V_{IL}$ ; AL or TTL' to ' $V_{IL}$ ; AL or TTL; except VGATE1P and  $T_J > 150^\circ\text{C}$ '

## History Changes from Version 0.4 to Version 0.6

- Change note of  $I_{PDL}$  from ' $V_{IL}$ ; AL or TTL' to ' $V_{IL}$ ; AL'
- Changes in table 'Slow 3.3V GPIO' of Standard Pads
  - Change min value of  $HYS$  from  $0.1 * V_{EXT/FLEX}$  V to  $0.09 * V_{EXT/FLEX}$  V
  - Change min value of  $HYS$  from  $0.065 * V_{EXT/FLEX}$  V to  $0.055 * V_{EXT/FLEX}$  V
  - Change min value of  $HYS$  from  $0.07 * V_{EXT/FLEX}$  V to  $0.055 * V_{EXT/FLEX}$  V
  - Change note of  $R_{DSON}$  from '140 Ohm' to '125 Ohm'
  - Change typ value of  $R_{DSON}$  from 200 Ohm to 225 Ohm
  - Change max value of  $R_{DSON}$  from 300 Ohm to 320 Ohm
  - Change note of  $t_{RF}$  from ' $4+0.57*C_L$  ns' to ' $2+0.57*C_L$  ns'
  - Change note of  $t_{RF}$  from ' $7+1.1*C_L$  ns' to ' $10+1.25*C_L$  ns'
  - Change note of  $I_{PUH}$  from ' $V_{IH}$ ; AL and TTL (degraded, used for CIF)' to ' $V_{IH}$ ; AL and TTL (degraded, used for CIF); except VGATE1P and  $T_J > 150^{\circ}C$ '
  - Change min value of  $I_{PUH}$  from |19|  $\mu A$  to |17|  $\mu A$
  - Change note of  $I_{PUH}$  from " $V_{IH}$ ; TTL" to " $V_{IH}$ ; TTL; except VGATE1P and  $T_J > 150^{\circ}C$ "
  - Change note of  $I_{PUH}$  from '|9|  $\mu A$ ' to '|11|  $\mu A$ '
  - Change min value of  $I_{PDL}$  from |18|  $\mu A$  to |15|  $\mu A$
  - Change note of  $I_{PUH}$  from ' $V_{IL}$ ; AL and TTL and TTL (degraded, used for CIF)' to ' $V_{IL}$ ; AL and TTL and TTL (degraded, used for CIF); except VGATE1P and  $T_J > 150^{\circ}C$ '
  - Change note of  $f_{OUTD}$  from " to 'medium driver'
- Changes in table ' $\overline{PORST}$  Pad' of Standard Pads
  - Change note of  $HYS$  from 'non of the neighbor pads are used as output; TTL' to 'non of the neighbor pads are used as output;TTL (degraded, used for CIF)'
  - Change min value of  $HYS$  from  $0.1 * V_{EXT/FLEX}$  V to  $0.055 * V_{EXT/FLEX}$  V
  - Change note of  $I_{PDL}$  from '|18|  $\mu A$ ' to '|15|  $\mu A$ '
  - Change note of  $HYS$  from 'two of the neighbor pads are used as output with driver=strong and edge=sharp; TTL' to 'two of the neighbor pads are used as output with driver=strong and edge=sharp; TTL (degraded, used for CIF)'
- Changes in table 'Class S 5V' of Standard Pads
  - Change min value of  $HYS$  from  $0.1 * V_{EXT/FLEX}$  V to  $0.09 * V_{EXT/FLEX}$  V
  - Change min value of  $HYS$  from  $0.09 * V_{EXT/FLEX}$  V to  $0.075 * V_{EXT/FLEX}$  V
  - Change note of  $I_{PDL}$  from ' $V_{IL}$ ; AL or TTL' to ' $V_{IL}$ ; AL'
- Changes in table 'RFast 3.3V pad' of Standard Pads
  - Change min value of  $HYS$  from  $0.065 * V_{EXT/FLEX}$  V to  $0.055 * V_{EXT/FLEX}$  V
  - Change min value of  $HYS$  from  $0.1 * V_{EXT/FLEX}$  V to  $0.09 * V_{EXT/FLEX}$  V
  - Change min value of  $HYS$  from  $0.07 * V_{EXT/FLEX}$  V to  $0.055 * V_{EXT/FLEX}$  V
  - Change min value of  $R_{DSON}$  from 140 Ohm to 125 Ohm
  - Change typ value of  $R_{DSON}$  from 200 Ohm to 225 Ohm
  - Change note of  $R_{DSON}$  from '300 Ohm' to '320 Ohm'
  - Change note of  $R_{DSON}$  from '35 Ohm' to '31 Ohm'
  - Change typ value of  $R_{DSON}$  from 50 Ohm to 55 Ohm
  - Change max value of  $R_{DSON}$  from 77 Ohm to 80 Ohm
  - Change note of  $R_{DSON}$  from '10 Ohm' to '8 Ohm'

## History Changes from Version 0.4 to Version 0.6

- Change note of  $t_{RF}$  from ' $C_L = 25\text{pF}$ ; driver = strong sharp edge' to ' $C_L = 25\text{pF}$ ; driver = strong sharp edge; from  $0.2 * V_{EXT/FLEX}$  to  $0.8 * V_{EXT/FLEX}$ '
- Change min value of  $t_{RF}$  from 2 ns to 1.6 ns
- Change min value of  $t_{RF}$  from  $4+0.57*C_L$  ns to  $2+0.57*C_L$  ns
- Change note of  $t_{RF}$  from ' $0.75+0.15*C_L$  ns' to ' $2.5+0.21*C_L$  ns'
- Change max value of  $t_{RF}$  from  $1.5+0.38*C_L$  ns to  $8+0.4*C_L$  ns
- Change max value of  $t_{RF}$  from  $7+1.1*C_L$  ns to  $10+1.25*C_L$  ns
- Change min value of  $I_{PUH}$  from |19|  $\mu\text{A}$  to |17|  $\mu\text{A}$
- Change note of  $I_{PUH}$  from '|9|  $\mu\text{A}$ ' to '|11|  $\mu\text{A}$ '
- Change min value of  $I_{PDL}$  from |18|  $\mu\text{A}$  to |15|  $\mu\text{A}$
- Change note of  $t_{RF}$  from ' $C_L = 25\text{pF}$ ; driver = strong sharp edge' to ' $C_L = 25\text{pF}$ ; driver = strong sharp edge; from  $0.2 * V_{EXT/FLEX}$  to  $0.8 * V_{EXT/FLEX}$ '
- Change note of  $f_{OUTD}$  from " to 'medium driver'
- Changes in table 'RFast 5V GPIO' of Standard Pads
  - Change min value of  $HYS$  from  $0.1 * V_{EXT/FLEX}$  V to  $0.09 * V_{EXT/FLEX}$  V
  - Change note of  $HYS$  from ' $0.09 * V_{EXT/FLEX}$  V' to ' $0.075 * V_{EXT/FLEX}$  V'
  - Change min value of  $R_{DSON}$  from 140 Ohm to 125 Ohm
  - Change max value of  $R_{DSON}$  from 260 Ohm to 320 Ohm
  - Change typ value of  $R_{DSON}$  from 200 Ohm to 225 Ohm
  - Change note of  $R_{DSON}$  from '35 Ohm' to '31 Ohm'
  - Change max value of  $R_{DSON}$  from 65 Ohm to 80 Ohm
  - Change note of  $R_{DSON}$  from '50 Ohm' to '55 Ohm'
  - Change note of  $t_{RF}$  from ' $2.5+0.18*C_L$  ns' to ' $1.0+0.18*C_L$  ns'
  - Change note of  $t_{RF}$  from ' $C_L = 25\text{pF}$ ; driver = strong sharp edge' to ' $C_L = 25\text{pF}$ ; driver = strong sharp edge; from  $0.2 * V_{EXT/FLEX}$  to  $0.8 * V_{EXT/FLEX}$ '
  - Change note of  $t_{RF}$  from '2.8 ns' to '3.2 ns'
  - Change min value of  $t_{RF}$  from  $0.5+0.075*C_L$  ns to  $0.5+0.08*C_L$  ns
  - Change note of  $t_{RF}$  from ' $0.5+0.15*C_L$  ns' to ' $1.0+0.17*C_L$  ns'
  - Change max value of  $t_{RF}$  from  $4+0.95*C_L$  ns to  $12+1.0*C_L$  ns
  - Change note of  $t_{RF}$  from ' $2.5+0.35*C_L$  ns' to ' $5.0+0.35*C_L$  ns'
  - Change note of  $t_{RF}$  from ' $C_L = 25\text{pF}$ ; driver = strong sharp edge' to ' $C_L = 25\text{pF}$ ; driver = strong sharp edge; from  $0.2 * V_{EXT/FLEX}$  to  $0.8 * V_{EXT/FLEX}$ '
  - Change note of  $f_{IND}$  from " to 'AL and TTL'
  - Change note of  $f_{OUTD}$  from " to 'medium driver'
  - Change note of  $I_{PDL}$  from ' $V_{IL}$ ; AL or TTL' to ' $V_{IL}$ ; AL'
- Changes in table 'Class D' of Standard Pads
  - Update footnote of *Standard Pads* to 'For AN11 200 nA need to be added.'
  - Change note of  $I_{OZ}$  from ' $T_J \leq 150^\circ\text{C}$ ; PDD option available, or AltRef option available and EDSADC channel connected' to ' $T_J \leq 150^\circ\text{C}$ ; PDD option available, or AltRef option available and EDSADC channel connected, or two EDSADC channels connected'
- Changes in table 'LVDS - IEEE standard LVDS general purpose link (GPL)' of LVDS Pads
  - Change max value of  $t_{rise20}$  from 0.5 ns to 0.75 ns
  - Change max value of  $t_{fall20}$  from 0.5 ns to 0.75 ns

## History Changes from Version 0.4 to Version 0.6

- Change max value of  $V_{OD}$  from 450 mV to 500 mV
- Change min value of  $V_{OD}$  from 360 mV to 380 mV
- VADC 5V
  - Change note of  $dV_{CSD}$  from '-20 %' to '-10 %'
  - Change note of  $dV_{CSD}$  from '20 %' to '10 %'
  - Change note of  $f_{ADCI}$  from 'Upper voltage range' to ' $4.5V \leq V_{DDM} \leq 5.5V$ '
  - Change note of  $t_{SCAL}$  from 'Upper voltage range' to ' $4.5V \leq V_{DDM} \leq 5.5V$ '
  - Change note of  $f_{ADCI}$  from 'Lower voltage range' to ' $2.97V \leq V_{DDM} < 4.5V$ '
  - Change note of  $t_S$  from 'Primary group or fast compare channel, upper voltage range; input buffer disabled' to 'Primary group or fast compare channel,  $4.5V \leq V_{DDM} \leq 5.5V$ ; input buffer disabled'
  - Change note of  $t_{SCAL}$  from 'Lower voltage range' to ' $2.97V \leq V_{DDM} < 4.5V$ '
  - Change note of  $t_S$  from 'Primary group or fast compare channel, upper voltage range; input buffer enabled' to 'Primary group or fast compare channel,  $4.5V \leq V_{DDM} \leq 5.5V$ ; input buffer enabled'
  - Change note of  $t_S$  from 'Secondary group, upper voltage range; input buffer disabled' to 'Secondary group,  $4.5V \leq V_{DDM} \leq 5.5V$ ; input buffer disabled'
  - Change note of  $t_S$  from 'Secondary group, upper voltage range; input buffer enabled' to 'Secondary group,  $4.5V \leq V_{DDM} \leq 5.5V$ ; input buffer enabled'
  - Change note of  $t_S$  from 'Primary Group or fast compare channel, lower voltage range; input buffer disabled' to 'Primary Group or fast compare channel,  $2.97V \leq V_{DDM} < 4.5V$ ; input buffer disabled'
  - Change note of  $t_S$  from 'Primary group or fast compare channel, lower voltage range; input buffer enabled' to 'Primary group or fast compare channel,  $2.97V \leq V_{DDM} < 4.5V$ ; input buffer enabled'
  - Change note of  $t_S$  from 'Secondary group, lower voltage range; input buffer disabled' to 'Secondary group,  $2.97V \leq V_{DDM} < 4.5V$ ; input buffer disabled'
  - Change note of  $t_S$  from 'Secondary group, lower voltage range; input buffer enabled' to 'Secondary group,  $2.97V \leq V_{DDM} < 4.5V$ ; input buffer enabled'
- DSADC 5V
  - Update wording in front of table DSADC 5V
  - Change note of  $DCF$  from ' $10^{-5} f_D$ , offset compensation filter enabled (FCFGMx.OEN = 001<sub>B</sub>)' to ' $10^{-5} f_D$ , offset compensation filter enabled (FCFGMx.OCEN = 001<sub>B</sub>)'
- OSC\_XTAL
  - Add parameter  $C_{XTAL1}$
  - Change typ value of  $C_{L1}$  from 2.35 pF to 3.35 pF
- Changes in table 'DTS PMS' of DTS
  - Change max value of  $t_M$  from 2.6 ms to 2.7 ms
- Add table 'DTS Core'
- Current Consumption
  - Update footnote of  $C_{\text{Current Consumption}}$  to 'A single DS channel instance consumes 4 mA.'
  - Change note of  $I_{DDRAIL}$  from '800 mA' to '840 mA'
  - Change note of  $I_{DDRAIL}$  from '920 mA' to '1100 mA'
  - Change note of  $I_{DDRAIL}$  from '960 mA' to '1100 mA'
  - Change note of  $I_{DDRAIL}$  from '1020 mA' to '1100 mA'
  - Change note of  $I_{DDRAIL}$  from '1110 mA' to '1100 mA'
  - Change note of  $I_{DDRAIL}$  from '1099 mA' to '1100 mA'

## History Changes from Version 0.4 to Version 0.6

- Changes in table 'Module Core Current Consumption' of Current Consumption
  - Change name of *Module Core Current Consumption* from Module Core Current Consumption to Module Core Current Consumption
  - Change max value of  $I_{DDC_{x0}}$  from 40 mA to 45 mA
  - Change note of  $I_{DDC_{x0}}$  from 'real power pattern' to 'real power pattern; IPC=0.6'
  - Change note of  $I_{DDC_{x0}}$  from '60 mA' to '70 mA'
  - Change note of  $I_{DDC_{x0}}$  from "max power pattern" to "max power pattern; IPC=1.2"
  - Change max value of  $I_{DDC_{xx}}$  from  $I_{DDC_{x0}} + 60$  mA to  $I_{DDC_{x0}} + 50$  mA
  - Change note of  $I_{DDC_{xx}}$  from 'max power pattern' to 'max power pattern; IPC=1.2'
  - Change max value of  $I_{DDGTM}$  from 60 mA to 100 mA
  - Change note of  $I_{DDGTM}$  from 'real power pattern; TIMx, TOMx, ATOMx , MCSx active. 5 clusters at 200 MHz.' to 'real power pattern; TIMx, TOMx, ATOMx , MCSx active. 3 clusters at 200 MHz.'
  - Change max value of  $I_{DDGTM}$  from 88 mA to 120 mA
  - Change note of  $I_{DDBIST}$  from '100 mA' to '200 mA'
  - Change note of  $I_{DDC_{xx}}$  from 'real power pattern' to 'real power pattern; IPC=0.6'
  - Change max value of  $I_{DDGTM}$  from 20 mA to 50 mA
  - Change note of  $I_{DDGTM}$  from 'TIMx, TOMx active at 100MHz. ATOMx , MCSx, DPLL inactive.' to 'TIMx, TOMx active at 100MHz. ATOMx , MCSx, DPLL inactive. 2 clusters at 100 MHz.'
  - Change max value of  $I_{EXTRAIL}$  from 58 mA to 50 mA
  - Change max value of  $I_{EXTRAIL}$  from t.b.d mA to 56 mA
  - Change max value of  $I_{EXTFLEX}$  from 30 mA to 18 mA
- Changes in table 'Module Current Consumption' of Current Consumption
  - Change max value of  $I_{EXTLVDS}$  from t.b.d mA to 20 mA
  - Change note of  $I_{SCRSB}$  from '4 mA' to '6.5 mA'
  - Change note of  $I_{SCRSB}$  from "SCR 8-bit Standby Controller in STANDBY Mode drawn at  $V_{EVR_{SB}}$  supply pin" to "SCR 8-bit Standby Controller current incl. PMS in STANDBY Mode drawn at  $V_{EVR_{SB}}$  supply pin"
  - Change note of  $I_{SCRSB}$  from "Additional SCR 8-bit Standby Controller current in STANDBY Mode drawn at  $V_{EVR_{SB}}$  supply pin" to "SCR 8-bit Standby Controller current incl. PMS in STANDBY Mode drawn at  $V_{EVR_{SB}}$  supply pin"
  - Change note of  $I_{SCRSB}$  from "SCR 8-bit Standby Controller current in STANDBY Mode incl. PMS current drawn at  $V_{EVR_{SB}}$  supply pin" to "SCR 8-bit Standby Controller current incl. PMS in STANDBY Mode drawn at  $V_{EVR_{SB}}$  supply pin"
  - Change note of  $I_{SCRSB}$  from "SCR power pattern;  $f_{SYS\_SCR} = 20$ MHz;  $T_J=150^{\circ}C$ " to "SCR power pattern incl. PMS current consumption with fback clock active;  $f_{SYS\_SCR} = 20$ MHz;  $T_J=150^{\circ}C$ "
  - Change typ value of  $I_{SCRSB}$  from 0.025 mA to 0.190 mA
  - Change note of  $I_{SCRSB}$  from 'real power pattern;  $f_{SYS\_SCR} = 70$ kHz;  $T_J=25^{\circ}C$ ' to 'SCR power pattern incl. PMS current consumption with fback inactive;  $f_{SYS\_SCR} = 70$ kHz;  $T_J=25^{\circ}C$ '
  - Change note of  $I_{SCRSB}$  from "SCR 8-bit Standby Controller in STANDBY Mode drawn at  $V_{EVR_{SB}}$  supply pin" to "SCR 8-bit Standby Controller current incl. PMS in STANDBY Mode drawn at  $V_{EVR_{SB}}$  supply pin"
  - Change note of  $I_{DDM}$  from '66 mA' to '32 mA'
  - Change note of  $I_{DDM}$  from "real power pattern ; current for EDSADC module only; 11 EDSADC channels active." to "real power pattern; current for EDSADC modules only and EVADC modules are inactive; 8 EDSADC channels active continuously."
  - Change note of  $I_{DDM}$  from '60 mA' to '45 mA'

## History Changes from Version 0.4 to Version 0.6

- Change note of  $I_{DDM}$  from "max power pattern; All EDSADC channels active 100% time." to "max power pattern; current for EDSADC modules only and EVADC modules are inactive; all EDSADC channels active continuously."
- Change note of  $I_{DDM}$  from 'real pattern; 12 EVADC modules active' to 'real power pattern; current for EVADC modules only and EDSADC modules are inactive; 12 EVADC modules active.'
- Change max value of  $I_{DDM}$  from 21 mA to 20 mA
- Change note of  $I_{DDM}$  from 'max power pattern; All EVADC modules are active 100% time' to 'max power pattern; current for EVADC modules only and EDSADC modules are inactive; all EVADC modules active.'
- Change max value of  $I_{DDM}$  from 56 mA to 48 mA
- Change max value of  $I_{SLEEP}$  from 10 mA to 25 mA
- Change max value of  $I_{DDTOT}$  from 924 mA to 978 mA
- Change max value of  $PD$  from t.b.d. mW to 1700 mW
- Change max value of  $PD$  from t.b.d. mW to 2400 mW
- Change note of  $I_{DDTOTDC5}$  from 't.b.d mA' to '440 mA'
- Change note of  $I_{DDTOTDC5}$  from "real power pattern;  $V_{EXT} = 5V$ ;  $T_J=150^{\circ}C$ " to "real power pattern; EVRC reset settings with 72% efficiency;  $V_{EXT} = 5V$ ;  $T_J=150^{\circ}C$ "
- Change description of  $I_{DDTOTDC5}$  from ' $\Sigma$  Sum of all currents with DC-DC EVR13 regulator active' to ' $\Sigma$  Sum of all currents with DC-DC EVRC regulator active'
- Change max value of  $I_{DDTOTDC3}$  from t.b.d. mA to 580 mA
- Change note of  $I_{DDTOTDC3}$  from 'real power pattern;  $V_{EXT} = 3.3V$ ;  $T_J=150^{\circ}C$ ' to 'real power pattern; EVRC reset settings with 72% efficiency;  $V_{EXT} = 3.3V$ ;  $T_J=150^{\circ}C$ '
- Change description of  $I_{DDTOTDC3}$  from ' $\Sigma$  Sum of all currents with DC-DC EVR13 regulator active' to ' $\Sigma$  Sum of all currents with DC-DC EVRC regulator active'
- Change max value of  $I_{EVRSB}$  from 4 mA to 8 mA
- Change note of  $I_{DDPORST}$  from '430 mA' to '490 mA'
- Reset
  - Change min value of  $t_{POH}$  from 100 ns to 150 ns
  - Change note of  $t_{BP}$  from ' $dV/dT=1V/ms$ . including EVR ramp-up and Firmware execution time; RAM initialization and HSM boot time is not included' to ' $dVEXT/dT=1V/ms$ .  $VEXT>VLVDRST5$ . Boot time after Cold PORST including EVR ramp-up and Firmware execution time; RAM initialization and HSM boot time are not included.'
  - Change note of  $t_B$  from 'operating with max. frequencies' to 'operating with max. frequencies, with valid BMI header'
  - Change note of  $t_{BS}$  from " to 'RAM initialization and HSM boot time are not included, with valid BMI header'
  - Change note of  $t_{BP}$  from 'Firmware execution time; without EVR ramp-up; RAM initialization and HSM boot time is not included' to 'Firmware execution time after warm PORST without EVR ramp-up; RAM initialization and HSM boot time is not included'
  - Change type of  $t_{POA}$  from CC to SR
  - Change description of  $t_{POA}$  from 'Minimum PORST active hold time externally after power supplies are stable at operating levels' to 'Minimum PORST active hold time externally after power supplies are stable at operating levels after start-up'
- PMS/EVR33 LDO
  - Change min value of  $C_{OUT}$  from 0.65  $\mu F$  to 1.45  $\mu F$
  - Change note of  $C_{OUT}$  from '1.35  $\mu F$ ' to '3  $\mu F$ '
  - Change note of  $C_{OUT}$  from '1  $\mu F$ ' to '2.2  $\mu F$ '

**History Changes from Version 0.4 to Version 0.6**

- Change min value of  $dV_{out}/dI_{out}$  from -100 mV to -180 mV
- Change max value of  $dV_{out}/dI_{out}$  from 100 mV to 180 mV
- Change note of  $I_{MAX}$  from '100 mA' to '60 mA'
- Change note of  $dV_{out}/dV_{in}$  from ' $dV_{in}/dT=50V/ms; dV= 5$  to  $3.6V$ ' to ' $dV_{in}/dT=50V/ms; dV= 5$  to  $3.6V; I_{MAX}=60mA$ '
- Change note of  $dV_{out}/dV_{in}$  from ' $dV_{in}/dT=50V/ms; dV= 3.6$  to  $5V$ ' to ' $dV_{in}/dT=50V/ms; dV= 3.6$  to  $5V; I_{MAX}=60mA$ '
- PMS/Supply Monitors
  - Change note of  $V_{LVDRST5}$  from '2.7 V' to '2.75 V'
  - Change note of  $V_{LVDRST5}$  from '2.67 V' to '2.72 V'
- PMS/Supply Ramp
  - Change description of  $SR\_V\_EXT$  from 'External  $V_{EXT}$  &  $V_{EVRSB}$  supply ramp' to 'External  $V_{EXT}$  &  $V_{EVRSB}$  supply ramp-up and ramp-down slope'
  - Change description of  $SR\_V\_DDP3$  from 'External  $V_{DDP3}$  supply ramp' to 'External  $V_{DDP3}$  supply ramp-up and ramp-down slope'
  - Change description of  $SR\_V\_DD$  from 'External  $V_{DD}$  supply ramp' to 'External  $V_{DD}$  supply ramp-up and ramp-down slope'
  - Change description of  $SR\_V\_DDM$  from 'External  $V_{DDM}$  supply ramp' to 'External  $V_{DDM}$  supply ramp-up and ramp-down slope'
- Changes in table 'EVRC SMPS' of PMS/EVRC SMPS
  - Change name of *EVRC SMPS* from EVR13 SMPS to EVRC SMPS
- Changes in table 'EVRC SMPS External components' of PMS/EVRC SMPS
  - Change name of *EVRC SMPS External components* from EVR13 SMPS External components to EVRC SMPS External components
- Changes in section JTAG Parameters
  - Update figure Test Clock Timing (TCK)
- Changes in section DAP Parameters
  - Combine figures Test Clock Timing (DAP0), DAP Timing Host to Device, and DAP Timing Device to Host (DAP1 and DAP2 pins) into single figure DAP Timing
  - Add  $t_{14}$  for condition F=40MHz
  - Add  $t_{15}$  for condition F=40MHz
  - Add  $t_{16}$  for condition F=40MHz
- Changes in table 'Master Mode strong sharp (ss) output pads' of ASCLIN
  - Change min value of  $t_{51}$  from -3 ns to -3.5 ns
  - Change max value of  $t_{51}$  from 3 ns to 3.5 ns
  - Change max value of  $t_{510}$  from 3 ns to 3.5 ns
- Changes in table 'Master Mode Timing, LVDS output pads for data and clock' of QSPI
  - Change note of  $t_{51}$  from '3 ns' to '4 ns'
  - Change note of  $t_{52}$  from '17 ns' to '18 ns'
- Changes in table 'Strong sharp (ss) driver for clock/data valid for 5V' of MSC
  - Change min value of  $t_{45}$  from -3 ns to -4 ns
  - Change note of  $t_{44}$  from '-3 ns' to '-4 ns'
- Changes in table 'ETH RGMII Signal Timing Parameters valid for 3.3V' of Ethernet

**History Changes from Version 0.6 to Version 0.7**

- Add parameter  $t_{21}$
- Changes in table 'ETH RMI Signal Timing Parameters valid for 3.3V' of Ethernet
  - Change description of  $t_{16}$  from 'ETHTXEN, ETHTXD[1:0], ETHRXD[1:0], ETHCRSDV, ETHRXER; setup time' to 'ETHTXEN, ETHTXD[1:0], ETHRXD[1:0], ETHCRSDV; setup time'
  - Change description of  $t_{17}$  from 'ETHTXEN, ETHTXD[1:0], ETHRXD[1:0], ETHCRSDV, ETHRXER; hold time' to 'ETHTXEN, ETHTXD[1:0], ETHRXD[1:0], ETHCRSDV; hold time'
- Changes in table 'HSCT - Rx/Tx setup timing' of LVDS Pads
  - Change max value of  $t_{tx}$  from 250 ns to 280 ns
- Flash
  - Change note of  $t_{ER\_Dev}$  from "Derived value for documentation purpose" to "Valid for less than 1000 cycles, w/o UCB. Derived value for documentation purpose."
  - Change note of  $t_{ER\_Dev}$  from '17.8 s' to '11.5 s'
  - Change max value of  $t_{PRPB5\_PF}$  from 16 s to 10 s
- Package Parameters
  - Update table Thermal Characteristics of the Package
  - Change package type from PG-LFBGA-516-9 to PG-LBGA-516-1
  - Change package type from PG-LFBGA-292-9 to PG-LFBGA-292-11

**4.2 Changes from Version 0.6 to Version 0.7**

- Changed step description from "AA" to "AB"
- Update of Data Flash to 512 KB in "Platform Feature Overview"
- Update AGBT to "no" in Platform feature overview table
- "BBB frequency" from table "Operating Conditions"
- Update Ctrl. for Pin ESR0
- Update Ctrl. for Pin ESR1
- Absolute Maximum Ratings
  - Change description of  $V_{DDM}$  from 'Voltage at  $V_{DDM}$ ,  $V_{EXT}$  and  $V_{FLEX}$  power supply pins with respect to  $V_{SS}$ ' to 'Voltage at  $V_{DDM}$ ,  $V_{EXT}$ ,  $V_{FLEX}$  and  $V_{EVRSB}$  power supply pins with respect to  $V_{SS}$ '
- Changes in table 'Overload Parameters' of Overload
  - Change note of  $I_{IN}$  from 'except LVDS pins' to 'except LVDS pins; limited to max. Operation Lifetime hours'
  - Change note of  $I_{INLVDS}$  from " to 'limited to max. Operation Lifetime hours'
  - Change note of  $I_{ID}$  from 'All power supply voltages  $V_{DDx} = 0$ ' to 'All power supply voltages  $V_{DDx} = 0$ ; limited to max. Inactive Lifetime hours'
  - Change note of  $I_{OUT}$  from '100% duty cycle; output driver = strong' to '100% duty cycle; output driver = strong; limited to max. Operation Lifetime hours'
  - Change of "Pin Reliability in Overload" praeamble
- Changes in table 'Slow 3.3V GPIO' of Standard Pads
  - Change note of  $V_{IL}$  from ' $0.44 * V_{EXT/FLEX}$  V' to ' $0.42 * V_{EXT/FLEX}$  V'
  - Change note of  $I_{PUH}$  from ' $V_{IH}$ ; AL and TTL (degraded, used for CIF); except VGATE1P and  $T_J > 150^{\circ}C$ ' to ' $V_{IH}$ ; AL and TTL (degraded, used for CIF); except VGATE1P; except VGATE1N and  $T_J > 150^{\circ}C$ '

## History Changes from Version 0.6 to Version 0.7

- Change note of  $I_{PUH}$  from ' $V_{IL}$ ; AL and TTL and TTL (degraded, used for CIF); except VGATE1P and  $T_J > 150^\circ\text{C}$ ' to ' $V_{IL}$ ; AL and TTL and TTL (degraded, used for CIF); except VGATE1P; except VGATE1N and  $T_J > 150^\circ\text{C}$ '
- Change note of  $I_{PUH}$  from ' $V_{IH}$ ; TTL; except VGATE1P and  $T_J > 150^\circ\text{C}$ ' to ' $V_{IH}$ ; TTL; except VGATE1P; except VGATE1N and  $T_J > 150^\circ\text{C}$ '
- Change description of  $t_{SET}$  from 'Pad set-up time' to 'Pad set-up time to get an software update of the configuration active'
- Change min value of  $I_{OZ}$  from -200 nA to -300 nA
- Change max value of  $I_{OZ}$  from 200 nA to 300 nA
- Change min value of  $I_{OZ}$  from -250 nA to -400 nA
- Change max value of  $I_{OZ}$  from 250 nA to 400 nA
- Change min value of  $I_{OZ}$  from -300 nA to -600 nA
- Change max value of  $I_{OZ}$  from 300 nA to 600 nA
- Change min value of  $I_{OZ}$  from -500 nA to -750 nA
- Change max value of  $I_{OZ}$  from 500 nA to 750 nA
- Change min value of  $I_{OZ}$  from -350 nA to -300 nA
- Change max value of  $I_{OZ}$  from 350 nA to 300 nA
- Change min value of  $I_{OZ}$  from -550 nA to -400 nA
- Change max value of  $I_{OZ}$  from 550 nA to 400 nA
- Change min value of  $I_{OZ}$  from -700 nA to -600 nA
- Change max value of  $I_{OZ}$  from 700 nA to 600 nA
- Change min value of  $I_{OZ}$  from -1100 nA to -750 nA
- Change max value of  $I_{OZ}$  from 1100 nA to 750 nA
- Change max value of  $I_{OZ}$  from 11000 nA to 18000 nA
- Change note of  $I_{OZ}$  from '-11000 nA' to '-18000 nA'
- Change max value of  $I_{OZ}$  from 22000 nA to 38000 nA
- Change min value of  $I_{OZ}$  from -22000 nA to -38000 nA
- Changes in table 'RFast 3.3V pad' of Standard Pads
  - Change note of  $V_{IL}$  from ' $0.44 * V_{EXT/FLEX}$  V' to ' $0.42 * V_{EXT/FLEX}$  V'
  - Change description of  $t_{SET}$  from 'Pad set-up time' to 'Pad set-up time to get an software update of the configuration active'
- Changes in table 'Fast 3.3V GPIO' of Standard Pads
  - Change note of  $V_{IL}$  from ' $0.44 * V_{EXT/FLEX}$  V' to ' $0.42 * V_{EXT/FLEX}$  V'
  - Change note of  $I_{OZ}$  from '-750 nA' to '-1100 nA'
  - Change note of  $I_{OZ}$  from '750 nA' to '1100 nA'
  - Change min value of  $I_{OZ}$  from -5000 nA to -6000 nA
  - Change note of  $I_{OZ}$  from '5000 nA' to '6000 nA'
  - Change min value of  $I_{OZ}$  from -1300 nA to -2000 nA
  - Change max value of  $I_{OZ}$  from 1300 nA to 2000 nA
  - Change min value of  $I_{OZ}$  from -2000 nA to -2500 nA
  - Change note of  $I_{OZ}$  from '2000 nA' to '2500 nA'
  - Change max value of  $I_{OZ}$  from 9000 nA to 13500 nA
  - Change min value of  $I_{OZ}$  from -9000 nA to -13500 nA

## History Changes from Version 0.6 to Version 0.7

- Change note of  $I_{OZ}$  from '-2300 nA' to '-1100 nA'
- Change min value of  $I_{OZ}$  from -5000 nA to -2000 nA
- Change note of  $I_{OZ}$  from '2300 nA' to '1100 nA'
- Change max value of  $I_{OZ}$  from 5000 nA to 2000 nA
- Change description of  $t_{SET}$  from 'Pad set-up time' to 'Pad set-up time to get an software update of the configuration active'
- Changes in table 'Fast 5V GPIO' of Standard Pads
  - Change max value of  $I_{OZ}$  from 750 nA to 1100 nA
  - Change min value of  $I_{OZ}$  from -750 nA to -1100 nA
  - Change min value of  $I_{OZ}$  from -5000 nA to -6000 nA
  - Change max value of  $I_{OZ}$  from 5000 nA to 6000 nA
  - Change note of  $I_{OZ}$  from '-1300 nA' to '-2000 nA'
  - Change max value of  $I_{OZ}$  from 1300 nA to 2000 nA
  - Change min value of  $I_{OZ}$  from -2000 nA to -2500 nA
  - Change max value of  $I_{OZ}$  from 2000 nA to 2500 nA
  - Change note of  $I_{OZ}$  from '9000 nA' to '13500 nA'
  - Change min value of  $I_{OZ}$  from -9000 nA to -13500 nA
  - Change note of  $I_{OZ}$  from '-2300 nA' to '-1100 nA'
  - Change note of  $I_{OZ}$  from '-5000 nA' to '-2000 nA'
  - Change max value of  $I_{OZ}$  from 2300 nA to 1100 nA
  - Change max value of  $I_{OZ}$  from 5000 nA to 2000 nA
  - Change description of  $t_{SET}$  from 'Pad set-up time' to 'Pad set-up time to get an software update of the configuration active'
- Changes in table 'Slow 5V GPIO' of Standard Pads
  - Change note of  $I_{OZ}$  from '-250 nA' to '-400 nA'
  - Change max value of  $I_{OZ}$  from 250 nA to 400 nA
  - Change min value of  $I_{OZ}$  from -350 nA to -600 nA
  - Change max value of  $I_{OZ}$  from 350 nA to 600 nA
  - Change note of  $I_{OZ}$  from '500 nA' to '750 nA'
  - Change note of  $I_{OZ}$  from '-500 nA' to '-750 nA'
  - Change min value of  $I_{OZ}$  from -200 nA to -300 nA
  - Change max value of  $I_{OZ}$  from 200 nA to 300 nA
  - Change note of  $I_{PUH}$  from ' $V_{IH}$ ; AL or TTL; except VGATE1P and  $T_J > 150^\circ\text{C}$ ' to ' $V_{IH}$ ;AL or TTL; except VGATE1P; except VGATE1N and  $T_J > 150^\circ\text{C}$ '
  - Change note of  $I_{PUH}$  from ' $V_{IL}$ ; AL or TTL; except VGATE1P and  $T_J > 150^\circ\text{C}$ ' to ' $V_{IL}$ ; AL or TTL; except VGATE1P; except VGATE1N and  $T_J > 150^\circ\text{C}$ '
  - Change description of  $t_{SET}$  from 'Pad set-up time' to 'Pad set-up time to get an software update of the configuration active'
  - Change min value of  $I_{OZ}$  from -350 nA to -300 nA
  - Change max value of  $I_{OZ}$  from 350 nA to 300 nA
  - Change min value of  $I_{OZ}$  from -550 nA to -400 nA
  - Change note of  $I_{OZ}$  from '550 nA' to '400 nA'
  - Change min value of  $I_{OZ}$  from -700 nA to -600 nA

## History Changes from Version 0.6 to Version 0.7

- Change max value of  $I_{OZ}$  from 700 nA to 600 nA
- Change min value of  $I_{OZ}$  from -1100 nA to -750 nA
- Change max value of  $I_{OZ}$  from 1100 nA to 750 nA
- Change max value of  $I_{OZ}$  from 11000 nA to 18000 nA
- Change min value of  $I_{OZ}$  from -11000 nA to -18000 nA
- Change note of  $I_{OZ}$  from '22000 nA' to '38000 nA'
- Change min value of  $I_{OZ}$  from -22000 nA to -38000 nA
- Changes in table 'Class S 5V' of Standard Pads
  - Change description of  $t_{SET}$  from 'Pad set-up time' to 'Pad set-up time to get an software update of the configuration active'
  - Change min value of  $I_{OZ}$  from -350 nA to -300 nA
  - Change note of  $I_{OZ}$  from '350 nA' to '300 nA'
  - Change min value of  $I_{OZ}$  from -700 nA to -600 nA
  - Change max value of  $I_{OZ}$  from 700 nA to 600 nA
- Changes in table 'Class D' of Standard Pads
  - Change min value of  $I_{OZ}$  from -350 nA to -300 nA
  - Change max value of  $I_{OZ}$  from 350 nA to 300 nA
  - Change min value of  $I_{OZ}$  from -700 nA to -600 nA
  - Change max value of  $I_{OZ}$  from 700 nA to 600 nA
- Changes in table 'RFast 5V GPIO' of Standard Pads
  - Change description of  $t_{SET}$  from 'Pad set-up time' to 'Pad set-up time to get an software update of the configuration active'
- Changes in table 'LVDS - IEEE standard LVDS general purpose link (GPL)' of LVDS Pads
  - Add parameter  $t_{SET\_LVDS}$
  - Change note of  $R_{in}$  from ' $1600\text{ mV} < V_I \leq 2000\text{ mV}$ ' to ' $V_I \leq 2000\text{ mV}$ '
- VADC 5V
  - Add parameter  $dVDDK$
  - Change note of  $V_{DDK}$  from " to 'Measured at low temperature.'
  - Change note of  $t_{SCAL}$  from ' $4.5\text{V} \leq V_{DDM} \leq 5.5\text{V}$ ' to ' $4.5\text{ V} \leq V_{DDM} \leq 5.5\text{ V}$ '
  - Change note of  $f_{ADCI}$  from ' $4.5\text{V} \leq V_{DDM} \leq 5.5\text{V}$ ' to ' $4.5\text{ V} \leq V_{DDM} \leq 5.5\text{ V}$ '
  - Change note of  $R_{PDD}$  from " to 'Measured at pad input voltage  $V_{IN} = V_{DDM} / 2$ .'
  - Change note of  $t_{SCAL}$  from ' $2.97\text{V} \leq V_{DDM} < 4.5\text{V}$ ' to ' $2.97\text{ V} \leq V_{DDM} < 4.5\text{ V}$ '
  - Change note of  $t_S$  from 'Primary group or fast compare channel,  $4.5\text{V} \leq V_{DDM} \leq 5.5\text{V}$ ; input buffer disabled' to 'Primary group or fast compare channel,  $4.5\text{ V} \leq V_{DDM} \leq 5.5\text{ V}$ ; input buffer disabled'
  - Change note of  $f_{ADCI}$  from ' $2.97\text{V} \leq V_{DDM} < 4.5\text{V}$ ' to ' $2.97\text{ V} \leq V_{DDM} < 4.5\text{ V}$ '
  - Change note of  $t_S$  from 'Primary group or fast compare channel,  $4.5\text{V} \leq V_{DDM} \leq 5.5\text{V}$ ; input buffer enabled' to 'Primary group or fast compare channel,  $4.5\text{ V} \leq V_{DDM} \leq 5.5\text{ V}$ ; input buffer enabled'
  - Change note of  $t_S$  from 'Secondary group,  $4.5\text{V} \leq V_{DDM} \leq 5.5\text{V}$ ; input buffer disabled' to 'Secondary group,  $4.5\text{ V} \leq V_{DDM} \leq 5.5\text{ V}$ ; input buffer disabled'
  - Change note of  $t_S$  from 'Secondary group,  $4.5\text{V} \leq V_{DDM} \leq 5.5\text{V}$ ; input buffer enabled' to 'Secondary group,  $4.5\text{ V} \leq V_{DDM} \leq 5.5\text{ V}$ ; input buffer enabled'
  - Change note of  $t_S$  from 'Primary Group or fast compare channel,  $2.97\text{V} \leq V_{DDM} < 4.5\text{V}$ ; input buffer disabled' to 'Primary Group or fast compare channel,  $2.97\text{ V} \leq V_{DDM} < 4.5\text{ V}$ ; input buffer disabled'

**History Changes from Version 0.6 to Version 0.7**

- Change note of  $t_s$  from 'Primary group or fast compare channel,  $2.97V \leq V_{DDM} < 4.5V$ ; input buffer enabled' to 'Primary group or fast compare channel,  $2.97 V \leq V_{DDM} < 4.5 V$ ; input buffer enabled'
- Change note of  $t_s$  from 'Secondary group,  $2.97V \leq V_{DDM} < 4.5V$ ; input buffer disabled' to 'Secondary group,  $2.97 V \leq V_{DDM} < 4.5 V$ ; input buffer disabled'
- Change note of  $t_s$  from 'Secondary group,  $2.97V \leq V_{DDM} < 4.5V$ ; input buffer enabled' to 'Secondary group,  $2.97 V \leq V_{DDM} < 4.5 V$ ; input buffer enabled'
- Change of "VADC Parameters" praeamble
- DSADC 5V
  - Add parameter  $R_{BIAS}$
  - Change type of  $I_{REF}$  from SR to CC
- Changes in table 'DTS Core' of DTS
  - Add parameter  $\Delta T$
- Current Consumption
  - Change max value of  $I_{DDP3RAIL}$  from '60 mA' to '50 mA'
- Changes in table 'Module Current Consumption' of Current Consumption
  - Change max value of  $I_{DDP3ERASE}$  from 20 mA to 25 mA
  - Add parameter  $I_{DDP3ERASE}$
  - Change description of  $I_{DDP3ERASE}$  from 'Current adder for' to ' $I_{DDP3}$  supply current for erasing of a Pflash or Dflash bank'
  - Change typ value of  $I_{SCR SB}$  from 0.190 mA to 0.150 mA
  - Change max value of  $I_{DDP3PROG}$  from '8 mA' to '9 mA'
  - Change max value of  $I_{DDP3PROG}$  from '20 mA' to '25 mA'
  - Change max value of  $I_{SCR SB}$  from '6.5 mA' to '7 mA'
  - Change max value of  $I_{SCRIDLE}$  from '1 mA' to '3.5 mA'
  - Change max value of  $I_{DDPORST}$  from "real power pattern;  $T_J=125^\circ C$ " to " $V_{DD} = 1.275V$ ;  $T_J=125^\circ C$ "
  - Change max value of  $I_{DDPORST}$  from '190 mA' to '185 mA'
  - Change max value of  $I_{SLEEP}$  from 25 mA to 27 mA
- Changes in table 'Module Core Current Consumption' of Current Consumption
  - Change max value of  $I_{DDGTM}$  from 120 mA to 125 mA
  - Change note of  $I_{DDPORST}$  from 'real power pattern;  $T_J=150^\circ C$ ' to ' $V_{DD} = 1.275V$ ;  $T_J=150^\circ C$ '
  - Change max value of  $I_{DDPORST}$  from 340 mA to 320 mA
  - Change note of  $I_{DDPORST}$  from 'real power pattern;  $T_J=160^\circ C$ ' to ' $V_{DD} = 1.275V$ ;  $T_J=160^\circ C$ '
  - Change max value of  $I_{DDPORST}$  from 450 mA to 400 mA
  - Change note of  $I_{DDPORST}$  from "real power pattern;  $T_J=165^\circ C$ " to " $V_{DD} = 1.275V$ ;  $T_J=165^\circ C$ "
  - Change note of  $I_{DDPORST}$  from '490 mA' to '430 mA'
- Reset
  - Change max value of  $t_{BS}$  from 1 ms to 1.05 ms
  - Change note of  $t_{BP}$  from 'Firmware execution time after warm PORST without EVR ramp-up; RAM initialization and HSM boot time is not included' to 'Firmware execution time after PORST release without EVR ramp-up; RAM initialization and HSM boot time is not included'
  - Change description of  $t_{BP}$  from 'Power on Reset Boot Time' to 'Cold Power on Reset Boot Time'
  - Change note of  $t_{LBIST}$  from 'PATTERNS=0x00040, FREQU=5, SPLITSH=4' to 'LBIST Configuration A'
  - Removed parameter  $t_{LBIST}$  with note 'PATTERNS=0x00280, FREQU=5, SPLITSH=4'

## History Changes from Version 0.6 to Version 0.7

- PMS/EVR33 LDO
  - Change note of  $dV_{out}/dV_{in}$  from " $dV_{in}/dT=1V/ms; dV= 3.6$  to  $5V$ " to " $dV_{in}/dT=1V/ms; dV= 3.6$  to  $5V; \Delta V_{OUTTC}$  is included"
  - Change note of  $dV_{out}/dV_{in}$  from ' $20$  mV' to ' $40$  mV'
  - Change min value of  $dV_{out}/dV_{in}$  from  $-20$  mV to  $-40$  mV
  - Change note of  $dV_{out}/dV_{in}$  from ' $dV_{in}/dT=1V/ms; dV= 5$  to  $3.6V$ ' to ' $dV_{in}/dT=1V/ms; dV= 5$  to  $3.6V; \Delta V_{OUTTC}$  is included'
  - Add parameter  $dV_{OUTTC}$
  - Change note of  $t_{STR}$  from " to 'Normal RUN mode'
- PMS/Supply Monitors
  - Change max value of  $V_{RSTC}$  from  $1.135$  V to  $1.138$  V
- Changes in table 'EVRC SMPS' of PMS/EVRC SMPS
  - Change max value of  $\Delta V_{DDDC}$  from  $12$  mV to  $16$  mV
- PLL Peripheral
  - Add parameter  $JABS25$
  - Change note of  $DP$  from ' $f_{DCO} = 640$  MHz' to ' $f_{DCO} = 640$  MHz or  $f_{DCO} = 800$  MHz'
  - Change note of  $D_{RMS}$  from 'measured over  $1$   $\mu$ s;  $f_{REF} = 20$  MHz;  $f_{DCO} = 640$  MHz' to 'measured over  $1$   $\mu$ s;  $f_{REF} = 20$  MHz and  $f_{DCO} = 640$  MHz or  $f_{REF} = 25$  MHz and  $f_{DCO} = 800$  MHz'
- Flash
  - Change note of  $N_{E\_HSMS}$  from 'Max. data retention time 10 years' to 'max data retention time 20y,  $T_j=85^{\circ}C$ '
  - Change note of  $N_{E\_EEP10S}$  from 'Max. data retention time 10 years' to 'max data retention time 20y,  $T_j=85^{\circ}C$ '
  - Add parameter  $N_{E\_EEP10S}$
  - Change max value of  $N_{E\_EEP10S}$  to 125000 cycles
  - Add parameter  $N_{E\_EEP10S}$
  - Change max value of  $N_{E\_EEP10S}$  to 125000 cycles
  - Add parameter  $N_{E\_EEP10S}$
  - Change max value of  $N_{E\_EEP10S}$  to 70000 cycles
  - Add parameter  $N_{E\_HSMS}$
  - Change max value of  $N_{E\_HSMS}$  to 125000 cycles
  - Add parameter  $N_{E\_HSMS}$
  - Change max value of  $N_{E\_HSMS}$  to 125000 cycles
  - Add parameter  $N_{E\_HSMS}$
  - Change max value of  $N_{E\_HSMS}$  to 70000 cycles
  - Add inactive time to Table 3-75 "Example Temperature Profile"
- Package Parameters
  - Update table layout for table 3-67
  - Change max value of  $R_{TH\_JA}$  from  $14,8$  K/W to  $17$  K/W
  - Change max value of  $R_{TH\_JA}$  from  $12$  K/W to  $14$  K/W
  - Change name of  $R_{TH\_JA}$  from Thermal resistance (junction to ambient) to  $R_{TH\_JA}$
  - Change description of  $R_{TH\_JA}$  from " to 'Thermal resistance (junction to ambient)'
  - Change max value of  $R_{TH\_JCT}$  from  $4.5$  K/W to  $3$  K/W
  - Change max value of  $R_{TH\_JCT}$  from  $4.7$  K/W to  $3$  K/W

## History Changes from Version 0.7 to Version 0.71

- Change max value of RTH\_JCB from 2.8 K/W to 2 K/W
- Change description of  $R_{TH\_JCB}$  from " to 'Thermal resistance (junction to case bottom)'
- Change note of RTH\_JCB from '3.5 K/W' to '2 K/W'

### 4.3 Changes from Version 0.7 to Version 0.71

- Pinning
  - Corrected descriptions of HSCT pins
  - Corrected descriptions of CCU\_PAD\_SYSCCLK pin
- Summary of Features
  - Included RGMII in the Ethernet description
- Platform feature overview
  - Corrected number of SDMMC modules from '1' to '0'
  - Corrected the value of MCDS from "yes" to "no"
  - Corrected number of QSPI modules from '6' to '5'
- Corrected 'LVDSH' to 'LVDS' in Section 'High performance LVDS Pads'
- Changes in table "Absolute Maximum Ratings"
  - Change value of Parameter "VDDM"
  - Change value of Parameter "VIN"
- Change preamble of Section "Overload"
- Changes in table "Overload Parameters" of Section "Overload"
  - Change condition of Parameter "IIN"
  - Change condition of Parameter "IINLVDS"
  - Change condition of Parameter "IOUT"
  - Change condition of Parameter "IINANA"
  - Delete Parameter "IID"
- Changes in table "PORST Pad" of Section "Switchable Pads"
  - Change reference voltage of Parameters and values from "VEXT/FLEX" to "VEXT"
- Changes in table "Class S" of Section "Switchable Pads"
  - Change reference voltage of Parameters and values from "VEXT/FLEX" to "VDDM"
- Changes in table "RFast 3.3V pad" of Section "Switchable Pads"
  - Change reference voltage of Parameters and values from "VEXT/FLEX" to "VFLEX"
- Changes in table "RFast 5V pad" of Section "Switchable Pads"
  - Change reference voltage of Parameters and values from "VEXT/FLEX" to "VFLEX"
- Changes in table "Fast 3.3V pad" of Section "Switchable Pads"
  - Change reference voltage of Parameters and values from "VEXT/FLEX" to "VEXT/FLEX/EVRSB"
- Changes in table "Fast 5V pad" of Section "Switchable Pads"
  - Change reference voltage of Parameters and values from "VEXT/FLEX" to "VEXT/FLEX/EVRSB"
- Changes in table "Slow 3.3V pad" of Section "Switchable Pads"
  - Change reference voltage of Parameters and values from "VEXT/FLEX" to "VEXT/FLEX/EVRSB"
- Changes in table "Slow 5V pad" of Section "Switchable Pads"
  - Change reference voltage of Parameters and values from "VEXT/FLEX" to "VEXT/FLEX/EVRSB"

- Changes in table "VADC 5V"
  - Add footnote to Parameter "QCON"
  - Update picture 'Equivalent Circuitry for Analog Inputs'
- Changes in table "DSADC 5V"
  - Change value of Parameter "EDGAIN"
  - Change value of Parameter "EDOFF"
  - Add footnote to Parameter "EDOFF"
  - Change value of Parameter "IREF"
  - Change value of Parameter "IRMS"
  - Add footnote to Parameter "IRMS"
  - Add footnote to Parameter "SNR"
  - Add footnote to Parameter "SFDR"
- Changes in table "Current Consumption"
  - Change Parameter description of "IDDRAIL"
  - Change condition of Parameter "ISTANDBY"
  - Change value of Parameter "ISTANDBY"
  - Change footnote of Parameter "ISTANDBY"
- Changes in table "Module Core Current Consumption" of Section "Current Consumption"
  - Change condition of Parameter "IDDLBIST"
  - Change value of Parameter "IDDLBIST"
  - Add footnote to Parameter "IDDLBIST"
  - Add footnote to Parameter "ISCRSB"
  - Change condition of Parameter "IDDMBIST"
- Added section "Calculating the 1.25V Current Consumption"
- Changes in table "Reset"
  - Change value of Parameter "tB"
  - Change value of Parameter "tBS"
  - Add footnote to Parameter "tEVRPOR"
  - Change value of Parameter "tBWP"
  - Change condition of Parameter "tLBIST"
  - Change Parameter description of "tLBIST"
- Changes in table "EVR33 LDO"
  - Change condition of Parameter "dVout/dIout"
  - Change condition of Parameter "Vout/dVin"
  - Change footnote of Parameter "IMAX"
- Changes in table "Supply Monitors"
  - Change condition of Parameter "tMON"
  - Change condition of Parameter "VDDMON"
  - Change condition of Parameter "VDDP3MON"
  - Change condition of Parameter "VEXTMON"
  - Add footnote to Parameter "VEXTMON"
  - Change condition of Parameter "VRST5"

## History Changes from Version 0.71 to Version 1.0

- Changes in table "Flash"
  - Change condition of Parameter "NE\_EEP10S"
  - Remove condition of Parameter "NE\_EEP10S"
  - Change condition of Parameter "NE\_HSMS"
  - Remove condition of Parameter "NE\_HSMS"
- Changes in table "Quality Parameters" of Section "Quality Declarations"
  - Change Parameter description of "VHBM1"
- Add Section "TC380 Carrier Tape"
- OSC\_XTAL
  - Removed parameter  $V_{ILBX}$
  - Removed parameter  $V_{IHBX}$
- Changes in table "Back-up Clock"
  - Update footnote of Parameters "fBACKT"
- Changes in table "PLL Peripheral"
  - Add Parameters "DPP"
  - Add Parameters "DPPI"
- Changes in table "Receive Parameters" of "E-ray Parameters"
  - Update Parameters description of "tdCCRxD01"

#### 4.4 Changes from Version 0.71 to Version 1.0

- Changes in chapter "Summary of Features"
  - Changed LMU Memory size from 128 Kbyte to 256 Kbyte
- Pinning
  - Corrected descriptions of Column "Buffer Type": PU2
- Changes in chapter Electrical Specification
  - Corrected/ added wording in sub-chapter 3.1 "Parameter Interpretation"
  - Added naming for temperature value, table 3-66, Example Operation Lifetime Profile
  - Changed naming for sub-chapter 3.16, from Phase Locked Loop (PLL) to System Phase Locked Loop (SYS\_PLL)
  - corrected temperature in "Summary of Features" section
- Changes in Absolute Maximum Table
  - Add footnote 2) to  $V_{DD}$
- Changes in Operating Conditions Table
  - Add footnote 1) to  $V_{DD}$
- Changes in table 'PORST Pad' of Standard Pads
  - Change min value of  $HYS$  from  $0.055 * V_{EXT/FLEX}$  V to  $0.055 * V_{EXT}$  V
  - Change note of  $I_{OZ}$  from 'TJ≤150°C ;  $(0.1 * V_{EXT/FLEX}) < V_{IN} < (0.9 * V_{EXT/FLEX})$ ' to 'TJ≤150°C ;  $(0.1 * V_{EXT}) < V_{IN} < (0.9 * V_{EXT})$ '
  - Changed footnote 1) from 10% to 90%  $V_{EXT/FLEX}$  10% to 90% pad supply voltage
  - Add footnote 2) to  $I_{PDL}$

**History Changes from Version 0.71 to Version 1.0**

- Add parameter  $V_{IH}$  for condition TTL,  $V_{EXT}$
- Add parameter  $V_{IL}$  for condition TTL,  $V_{EXT}$
- Changes in table 'Fast 5V GPIO' of Standard Pads
  - Change min value of  $V_{IH}$  from  $0.7 * V_{EXT/FLEX}$  V to  $0.7 * V_{EXT/FLEX/EVRSB}$  V
  - Change note of  $V_{IL}$  from ' $0.44 * V_{EXT/FLEX}$  V' to ' $0.44 * V_{EXT/FLEX/EVRSB}$  V'
  - Change note of  $V_{ILD}$  from 'max. variation of 1ms;  $V_{DDM} = \text{constant}$ ; AL' to 'max. variation of 1ms;  $V_{EXT/FLEX/EVRSB} = \text{constant}$ ; AL'
  - Combined equal values of  $I_{OZ}$  in single line
  - Add footnote 4) to  $I_{PUH}$
  - Add footnote 5) to  $I_{PDL}$
- Changes in table 'Fast 3.3V GPIO' of Standard Pads
  - Change min value of  $V_{IH}$  from  $0.7 * V_{EXT/FLEX}$  V to  $0.7 * V_{EXT/FLEX/EVRSB}$  V
  - Change note of  $V_{IL}$  from ' $0.42 * V_{EXT/FLEX}$  V' to ' $0.42 * V_{EXT/FLEX/EVRSB}$  V'
  - Change note of  $V_{ILD}$  from 'max. variation of 1ms;  $V_{DDM} = \text{constant}$ ; AL' to 'max. variation of 1ms;  $V_{EXT/FLEX/EVRSB} = \text{constant}$ ; AL'
  - Combined equal values of  $I_{OZ}$  in single line
  - Add footnote 4) to  $I_{PUH}$
  - Add footnote 5) to  $I_{PDL}$
- Changes in table 'Slow 5V GPIO' of Standard Pads
  - Change min value of  $V_{IH}$  from  $0.7 * V_{EXT/FLEX}$  V to  $0.7 * V_{EXT/FLEX/EVRSB}$  V
  - Change note of  $V_{IL}$  from ' $0.44 * V_{EXT/FLEX}$  V' to ' $0.44 * V_{EXT/FLEX/EVRSB}$  V'
  - Change note of  $V_{ILD}$  from 'max. variation of 1ms;  $V_{DDM} = \text{constant}$ ; AL' to 'max. variation of 1ms;  $V_{EXT/FLEX/EVRSB} = \text{constant}$ ; AL'
  - Combined equal values of  $I_{OZ}$  in single line
  - Add footnote 4) to  $I_{PUH}$
  - Add footnote 5) to  $I_{PDL}$
- Changes in table 'Slow 3.3V GPIO' of Standard Pads
  - Change min value of  $V_{IH}$  from  $0.7 * V_{EXT/FLEX}$  V to  $0.7 * V_{EXT/FLEX/EVRSB}$  V
  - Change note of  $V_{IL}$  from ' $0.42 * V_{EXT/FLEX}$  V' to ' $0.42 * V_{EXT/FLEX/EVRSB}$  V'
  - Change note of  $V_{ILD}$  from 'max. variation of 1ms;  $V_{DDM} = \text{constant}$ ; AL' to 'max. variation of 1ms;  $V_{EXT/FLEX/EVRSB} = \text{constant}$ ; AL'
  - Combined equal values of  $I_{OZ}$  in single line
  - Add footnote 4) to  $I_{PUH}$
  - Add footnote 5) to  $I_{PDL}$
- Changes in table 'RFast 5V GPIO' of Standard Pads
  - Change min value of  $HYS$  from  $0.09 * V_{EXT/FLEX}$  V to  $0.09 * V_{FLEX}$  V
  - Change note of  $HYS$  from ' $0.075 * V_{EXT/FLEX}$  V' to ' $0.075 * V_{FLEX}$  V'
  - Change min value of  $V_{IH}$  from  $0.7 * V_{EXT/FLEX}$  V to  $0.7 * V_{FLEX}$  V
  - Change note of  $V_{IL}$  from ' $0.44 * V_{EXT/FLEX}$  V' to ' $0.44 * V_{FLEX}$  V'
  - Change note of  $t_{RF}$  from ' $C_L = 25\text{pF}$ ; driver = strong sharp edge; from  $0.2 * V_{EXT/FLEX}$  to  $0.8 * V_{EXT/FLEX}$ ' to ' $C_L = 25\text{pF}$ ; driver = strong sharp edge; from  $0.2 * V_{FLEX}$  to  $0.8 * V_{FLEX}$ '
  - Change note of  $I_{OZ}$  from ' $T_J \leq 170^\circ\text{C}$ ;  $(0.1 * V_{EXT/FLEX}) < V_{IN} < (0.9 * V_{EXT/FLEX})$ ' to ' $T_J \leq 170^\circ\text{C}$ ;  $(0.1 * V_{FLEX}) < V_{IN} < (0.9 * V_{FLEX})$ '

**History Changes from Version 0.71 to Version 1.0**

- Change note of  $I_{OZ}$  from ' $T_J \leq 150^\circ\text{C}$ ;  $(0.1 * V_{EXT/FLEX}) < V_{IN} < (0.9 * V_{EXT/FLEX})$ ' to ' $T_J \leq 150^\circ\text{C}$ ;  $(0.1 * V_{FLEX}) < V_{IN} < (0.9 * V_{FLEX})$ '
- Change note of  $V_{ILD}$  from 'max. variation of 1ms;  $V_{DDM} = \text{constant}$ ; AL' to 'max. variation of 1ms;  $V_{FLEX} = \text{constant}$ ; AL'
- Add footnote 4) to  $I_{PUH}$
- Add footnote 5) to  $I_{PDL}$
- Changes in table 'RFast 3.3V pad' of Standard Pads
  - Change min value of  $HYS$  from  $0.055 * V_{EXT/FLEX}$  V to  $0.055 * V_{FLEX}$  V
  - Change min value of  $HYS$  from  $0.09 * V_{EXT/FLEX}$  V to  $0.09 * V_{FLEX}$  V
  - Change min value of  $HYS$  from  $0.055 * V_{EXT/FLEX}$  V to  $0.055 * V_{FLEX}$  V
  - Change note of  $V_{IH}$  from ' $0.7 * V_{EXT/FLEX}$  V' to ' $0.7 * V_{FLEX}$  V'
  - Change note of  $V_{IL}$  from ' $0.42 * V_{EXT/FLEX}$  V' to ' $0.42 * V_{FLEX}$  V'
  - Change note of  $t_{RF}$  from ' $C_L = 25\text{pF}$ ; driver = strong sharp edge; from  $0.2 * V_{EXT/FLEX}$  to  $0.8 * V_{EXT/FLEX}$ ' to ' $C_L = 25\text{pF}$ ; driver = strong sharp edge; from  $0.2 * V_{FLEX}$  to  $0.8 * V_{FLEX}$ '
  - Change note of  $I_{OZ}$  from ' $T_J \leq 170^\circ\text{C}$ ;  $(0.1 * V_{EXT/FLEX}) < V_{IN} < (0.9 * V_{EXT/FLEX})$ ' to ' $T_J \leq 170^\circ\text{C}$ ;  $(0.1 * V_{FLEX}) < V_{IN} < (0.9 * V_{FLEX})$ '
  - Change note of  $V_{ILD}$  from 'max. variation of 1ms;  $V_{DDM} = \text{constant}$ ; AL' to 'max. variation of 1ms;  $V_{FLEX} = \text{constant}$ ; AL'
  - Add footnote 4) to  $I_{PUH}$
  - Add footnote 5) to  $I_{PDL}$
- Changes in table 'Class S 5V' of Standard Pads
  - Change min value of  $HYS$  from  $0.09 * V_{EXT/FLEX}$  V to  $0.09 * V_{DDM}$  V
  - Change min value of  $HYS$  from  $0.075 * V_{EXT/FLEX}$  V to  $0.075 * V_{DDM}$  V
  - Change min value of  $V_{IH}$  from  $0.7 * V_{EXT/FLEX}$  V to  $0.7 * V_{DDM}$  V
  - Change note of  $V_{IL}$  from ' $0.44 * V_{EXT/FLEX}$  V' to ' $0.44 * V_{DDM}$  V'
  - Add footnote 2) to  $I_{PUH}$
  - Add footnote 3) to  $I_{PDL}$
- Add table 'Class S 3.3V' of Standard Pads
- Changes in table 'ADC Reference Pads' of Standard Pads
  - Change note of  $I_{OZ2}$  from ' $T_J \leq 150^\circ\text{C}$ ;  $V_{AREF} \leq V_{DDM} + 50\text{mV}$ ; used for EVADC' to ' $T_J \leq 150^\circ\text{C}$ ;  $V_{AREF} \leq V_{DDM} + 50\text{mV}$ ; for EVADC; valid for BGA516 and Bare Die'
  - Change note of  $I_{OZ2}$  from ' $T_J \leq 150^\circ\text{C}$ ;  $V_{AREF} < V_{DDM}$ ; used for EDSADC' to ' $T_J \leq 150^\circ\text{C}$ ;  $V_{AREF} < V_{DDM}$ ; for EDSADC'
  - Change note of  $I_{OZ2}$  from ' $T_J \leq 150^\circ\text{C}$ ;  $V_{AREF} \leq V_{DDM} + 50\text{mV}$ ; used for EDSADC' to ' $T_J \leq 150^\circ\text{C}$ ;  $V_{AREF} \leq V_{DDM} + 50\text{mV}$ ; for EDSADC'
  - Change value of  $I_{OZ2}$  from ' $T_J \leq 150^\circ\text{C}$ ;  $V_{AREF} < V_{DDM}$ ; used for EVADC' to ' $T_J \leq 150^\circ\text{C}$ ;  $V_{AREF} < V_{DDM}$ ; for EVADC; valid for BGA516 and Bare Die'
  - Change note of  $I_{OZ2}$  from ' $T_J \leq 170^\circ\text{C}$ ;  $V_{AREF} < V_{DDM}$ ; used for EDSADC' to ' $T_J \leq 170^\circ\text{C}$ ;  $V_{AREF} < V_{DDM}$ ; for EDSADC'
  - Change note of  $I_{OZ2}$  from ' $T_J \leq 170^\circ\text{C}$ ;  $V_{AREF} \leq V_{DDM} + 50\text{mV}$ ; used for EDSADC' to ' $T_J \leq 170^\circ\text{C}$ ;  $V_{AREF} \leq V_{DDM} + 50\text{mV}$ ; for EDSADC'
  - Change note of  $I_{OZ2}$  from ' $T_J \leq 170^\circ\text{C}$ ;  $V_{AREF} \leq V_{DDM} + 50\text{mV}$ ; used for EVADC' to ' $T_J \leq 170^\circ\text{C}$ ;  $V_{AREF} \leq V_{DDM} + 50\text{mV}$ ; for EVADC; valid for BGA516 and Bare Die'

## History Changes from Version 0.71 to Version 1.0

- Change note of  $I_{OZ2}$  from ' $T_J \leq 170^\circ\text{C}; V_{AREF} < V_{DDM}$ ; used for EVADC' to ' $T_J \leq 170^\circ\text{C}; V_{AREF} < V_{DDM}$ ; for EVADC; valid for BGA516 and Bare Die'
- Added values for  $I_{OZ2}$
- Add footnote 1)
- Add footnote 2)
- Add footnote 3)
- LVDS - IEEE standard LVDS general purpose link (GPL)
  - Added footnote 1) for max. value  $t_{rise20}$
  - Added footnote 2) for max. value  $t_{fall20}$
  - Changed footnote number 1) for  $V_{OD}$  to footnote number 3)
  - Changed footnote number 2) for  $V_{ODSM}$  to footnote number 4)
  - Changed marking in figure 'LVDS Input model' from 'LVDSH IN' to 'LVDS IN'
- VADC 5V
  - Change note of  $V_{AREF}$  from " to ' $4.5\text{ V} \leq V_{DDM} \leq 5.5\text{ V}$ '
  - Change min value of  $V_{AREF}$  from  $V_{DDMnom} * 0.9\text{ V}$  to  $4.5\text{ V}$
  - Add min value of  $V_{AREF}$
  - Add typ value of  $V_{AREF}$
  - Add max value of  $V_{AREF}$
  - Add note of  $V_{AREF}$  to ' $2.97\text{ V} \leq V_{DDM} \leq 4.5\text{ V}$ '
  - Add footnote 1)
- DSADC 5V
  - Change min value of  $V_{AREF}$  from  $V_{DDMnom} * 0.9\text{ V}$  to  $4.5\text{ V}$
  - Add max value of  $I_{REF}$  at high temperature
- OSC\_XTAL
  - Add parameter for  $DC_{x1}$
  - Add parameter for  $J_{ABSX1}$
  - Add parameter for  $SR_{XTAL1}$
  - Add footnote 3)
- Back-up Clock
  - Change min value of  $f_{SB}$  from 30 kHz to 25 kHz
  - Change note of  $I_{f_{BACKT}}$  from 'A short term trimming providing the accuracy required by LIN communication is possible by periodic trimming every 2 ms for temperature and voltage drifts ' to 'A short term trimming providing the accuracy required by LIN communication is possible by periodic trimming every 2 ms for temperature and voltage drifts up to temperatures of 125 celcius'
- DTS
  - Change note of  $T_{NL}$  from " to ' $T_{CALACC}$  has to be added in addition'
- Power Supply Current
  - Changes in conditions from 'four lockstep cores' to 'two lockstep cores'
- Current Consumption
  - Change max value of  $I_{DDPORST}$  from '185 mA' to '160 mA'
  - Change max value of  $I_{DDPORST}$  from '320 mA' to '290 mA'
  - Change max value of  $I_{DDPORST}$  from '400 mA' to '350 mA'

## History Changes from Version 0.71 to Version 1.0

- Change max value of  $I_{DDPORST}$  from '430 mA' to '380 mA'
- Changed footnote 3)
- Module Current Consumption
  - Add parameter of  $I_{EXTLVDS}$  for receive
- Module Core Current Consumption
  - Changed footnote 1)
- Changes in chapter “Calculating the 1.25 V Current Consumption”
  - Changes in formula (3.2)
- Changes in chapter “Supply Ramp-up and Ramp-down Behavior”
  - Changed Figure and textual description for figure “Single Supply Mode (a) - VEXT (5 V) single supply”
  - Changed Figure and textual description for figure “Single Supply Mode (e) - (VEXT & VDDP3) 3.3 V single supply”
  - Changed Figure and textual description for figure “Single Supply Mode (d) - VEXT and VDD externally supplied”
  - Changed Figure and textual description for figure “Single Supply Mode (h) - VEXT, VDDP3 and VDD externally supplied”
- Reset Timing
  - Add parameter  $t_{WARMRSTSEQ}$
- PMS/Supply Monitors
  - Changed min value of  $V_{EXTMON}$  from '3.235 V to 3.2 V', and max value from '3.365 V' to '3.4 V'
  - Added footnote 5) for  $V_{DDMON}$
- EVRC SMPS
  - Added typ. value of '0.8 MHz' and note for  $f_{DCDC}$
  - Added values for  $L_{DC}$  for ' $f_{DCDC} = 0.8$  MHz'
- Add chapter FSP Parameters
- PLL System
  - Deleted values for  $f_{MV}$  for 'Modulation variation frequency'
- Table 'Master Mode Timing'
  - Added footnote 1)
- Table 'LVDS clock/data'
  - Added footnote 3)
- Flash
  - Add parameter for  $N_{DFDC}$
  - Add parameter for  $N_{UCBD}$
  - Add parameter  $t_{VER\_PAGE\_DC}$
  - Change description of  $t_{VER\_PAGE\_DC}$  from 'Data Flash Erase Verify time per page' to 'Data Flash Erase Verify time per page (Complement Sensing)'
  - Change name of  $t_{VER\_PAGE\_DS}$  from  $t_{VER\_PAGE\_D}$  to  $t_{VER\_PAGE\_DS}$
  - Change description of  $t_{VER\_PAGE\_DS}$  from 'Data Flash Erase Verify time per page' to 'Data Flash Erase Verify time per page (Single Ended Sensing)'
  - Change note of  $t_{RTU}$  from 'Max. 100 erase/program cycles per UCB, max 400 erase/program cycles for all UCBs together' to 'Max. 100 erase/program cycles per UCB, max 500 erase/program cycles for all UCBs together'

## History Changes from Version 1.0 to Version 1.1

- Package Parameters
  - Change max value of RTH\_JCT from 3 K/W to 5 K/W for LFBGA292
  - Change max value of RTH\_JCT from 3 K/W to 5 K/W for LFBGA516
- TC380 Carrier Tape
  - Added disclaimer for TC380
  - Changed X and Y values for 'TC380 Chip Dimensions'
  - Changed figure for 'Carrier Tape Dimensions'
  - Added accuracy value for 'TC380 Chip Dimensions'
- Summary of Features
  - Removed ASIL value from table 'Platform Feature Overview'

#### 4.5 Changes from Version 1.0 to Version 1.1

- Changes in table “Platform Feature Overview” - changed package types
- Changes on title page and chapter heads – AD/AE-Step”
- Changes in table “Platform Feature Overview” – package naming spelling of LFBGA-516-1 and LFBGA-292-11
- Change in table “Platform Feature Overview” – spelling of “HSPDM”
- Chapter “Bare Die Variant Pin Configuration of TC38x” - added information concerning “neighbor pads” after table “Pad List”
- Changes in chapter “Legend”
  - Added information concerning I/O-Spirit file version
  - Changed referring IO\_Spirit\_file version
  - Changed explanation for PD2 = with pull-down device connected during startup and reset, HighZ in Standby mode
- Changes in table “Absolute Maximum Ratings”
  - Changed description for parameter “Absolute maximum sum”
  - Added footnote 5)
- Changes in table 'Slow 5V GPIO' of Standard Pads
  - Changed conditions of parameter  $I_{OZ}$
  - Changed value of parameter  $V_{IL}$
- Changes in table “Slow 3.3V GPIO” of Standard Pads
  - Changed conditions of parameter  $I_{OZ}$
- Changes in table “RFast 3.3V pad” of Standard Pads
  - Deleted parameter for  $f_{IND}$
- Changes in table “LVDS - IEEE standard LVDS general purpose link (GPL)” of LVDS Pads
  - Changed value of parameter  $V_I$
  - Changed condition of parameter  $V_{idth}$
  - Added values for parameter  $V_{idth}$
  - Changed condition of parameter  $R_{in}$
  - Added notes/ hints to table footnotes for “Driver ground potential difference” and for parameter “RT”
- Changes in table “VADC 5V”
  - Added condition for parameter  $V_{AIN}$

## History Changes from Version 1.1 to Version 1.2

- Changes in table “DSADC 5V”
  - Added value for parameter  $I_{RMS}$
  - Changed footnotes of parameter  $ED_{GAIN}$
  - Changed footnotes of parameter  $ED_{OFF}$
  - Added footnote 4) for parameter  $ED_{GAIN}$
- Changes in table “OSC\_XTAL”
  - Changed footnote 1) for parameter  $t_{OSCS}$
- Changes in table “Current Consumption”
  - Deleted footnote 1) for parameter  $I_{EXTFLEX}$
  - Changed value in footnote 1)
  - Changed explanation in footnote 6)
- Changes in table “Module Current Consumption”
  - Changed values of parameter  $I_{EXTLVDS}$
  - Changed conditions of parameter  $I_{EXTLVDS}$
  - Changed value in footnote 6)
- Changes in table “Reset”
  - Changed values of parameter  $t_{SCR}$
- Changes in table “Supply Ramp”
  - Added note “power-cycles” to supply ramp table
- Changes in table “EVRC SMPS”
  - Changed symbol for parameter “ $\Delta f_{DCSPR}$ ”
- Changes in table “PLL System”
  - Changed value for parameter  $f_{REF}$
- Changes in table “ETH RGMII Parameters”
  - Added figures for ETH RGMII TX and RX signals
- Changes in table “Quality Parameters”
  - Changed value for parameter  $V_{HBM1}$
- Changes in chapter “Package Outline” - changed package types
- Changes in sub-chapter “TC380 Carrier Tape”
  - Changed number of figure “Carrier Tape Dimensions”

#### 4.6 Changes from Version 1.1 to Version 1.2

- Changes in chapter “Revision History”
  - Chronology completed
- Changes in chapter “Summary of Features”
  - Changed wording for “DFLASH”
  - Added description for “AEC-Q100”
  - Added description for “ISO 26262 Safety Element”
  - Added description for Data Flash in table “Platform Feature Overview”
  - Changed figure for GTM clusters in table “Platform Feature Overview”

**History Changes from Version 1.1 to Version 1.2**

- Changed figures for GTM/CDTM/DTM modules in table “Platform Feature Overview”
- Changed package type in table “Platform Feature Overview”
- Changes in chapter “Pin Definition and Functions”
  - Changed EDSADC function description for Port 00 in “BGA-516 Package Variant” tables
  - Changed EDSADC function description for Port 01 in “BGA-516 Package Variant” tables
  - Changed EDSADC function description for Port 02 in “BGA-516 Package Variant” tables
  - Changed PSI5S function description for Port 02 in “BGA-516 Package Variant” tables
  - Deleted PMS parameter for Port 02 in “BGA-516 Package Variant” tables
  - Deleted SCU parameter at Port 10 in “BGA-516 Package Variant” tables
  - Added PMS parameter at Port 10 in “BGA-516 Package Variant” tables
  - Changed Buffer Type description for P11.5, P11.7, P11.8, P11.9, P11.10, P11.11, P11.12 at Port 11 in “BGA-516 Package Variant” tables
  - Changed function description for GETH at Port 11 in “BGA-516 Package Variant” tables
  - Changed function description for GTM at Port 11 in “BGA-516 Package Variant” tables
  - Deleted parameter for SCU at Port 14 in “BGA-516 Package Variant” tables
  - Added parameter for PMS at Port 14 in “BGA-516 Package Variant” tables
  - Changed function description for GTM at Port 14 in “BGA-516 Package Variant” tables
  - Changed function description for HSCT0 at Port 20 in “BGA-516 Package Variant” tables
  - Changed function description for GTM at Port 20 in “BGA-516 Package Variant” tables
  - Added function description for DMU at Port 21 in “BGA-516 Package Variant” tables
  - Changed function description for HSCT0 at Port 21 in “BGA-516 Package Variant” tables
  - Changed function description for GTM at Port 23 in “BGA-516 Package Variant” tables
  - Changed EDSADC function description for Port 33 in “BGA-516 Package Variant” tables
  - Changed function description for GTM at Port 33 in “BGA-516 Package Variant” tables
  - Changed PSI5S function description for Port 33 in “BGA-516 Package Variant” tables
  - Added notes to table “System I/O” for “BGA-516 Package Variant”
  - Changed “Ctrl.” information for balls M21, L21 in “System I/O” table for “BGA-516 Package Variant”
  - Changed function description for ball M22 in “System I/O” table for “BGA-516 Package Variant”
  - Changed “Ctrl.” information for balls M22 in “System I/O” table for “BGA-516 Package Variant”
  - 
  - Changed function descriptions for EDSADC at Port 00 in “BGA-292 Package Variant” tables
  - Changed function descriptions for EDSADC at Port 01 in “BGA-292 Package Variant” tables
  - Changed function descriptions for EDSADC at Port 02 in “BGA-292 Package Variant” tables
  - Changed function descriptions for PSI5S at Port 02 in “BGA-292 Package Variant” tables
  - Changed GTM input channel at Port 02 in “BGA-292 Package Variant” tables
  - Deleted parameter for PMS at Port 02 in “BGA-292 Package Variant” tables
  - Deleted parameter for SCU at Port 10 in “BGA-292 Package Variant” tables
  - Added parameter for PMS at Port 10 in “BGA-292 Package Variant” tables
  - Changed Buffer Type description for P11.5, P11.7, P11.8, P11.9, P11.10, P11.11, P11.12 at Port 11 in “BGA-292 Package Variant” tables
  - Changed function description for GETH at Port 11 in “BGA-292 Package Variant” tables

## History Changes from Version 1.1 to Version 1.2

- Changed GTM input channel at Port 11 in “BGA-292 Package Variant” tables
  - Deleted parameter for SCU at Port 14 in “BGA-292 Package Variant” tables
  - Added parameter for PMS at Port 14 in “BGA-292 Package Variant” tables
  - Changed GTM input channel at Port 14 in “BGA-292 Package Variant” tables
  - Added function description for DMU at Port 21 in “BGA-292 Package Variant” tables
  - Changed function description for HSCT0 at Port 21 in “BGA-292 Package Variant” tables
  - Changed GTM input channel at Port 23 in “BGA-292 Package Variant” tables
  - Changed function descriptions for EDSADC at Port 33 in “BGA-292 Package Variant” tables
  - Changed GTM input channel at Port 33 in “BGA-292 Package Variant” tables
  - Changed PSI5S function description for Port 33 in “BGA-292 Package Variant” tables
  - Added notes to table “System I/O” for “BGA-292 Package Variant”
  - Changed “Ctrl.” information for balls G16, F16, G17 in “System I/O” table for “BGA-292 Package Variant”
  - Changed function description for ball G17 in “System I/O” table for “BGA-292 Package Variant”
  - 
  - Changed sub-chapter title from “Bare Die Variant Pin Configuration of TC38x” to “Sequence of Pads in Pad Frame”
  - Changed comments for pad name VDDP3 (62, 64) in Pad List of “Sequence of Pads in Pad Frame”
  - Changed pad type for pad names P11.5, P11.7, P11.9, P11.8, P11.10, P11.11, P11.12 in Pad List of “Sequence of Pads in Pad Frame”
  - Changed comments for pads 158, 159 in Pad List of “Sequence of Pads in Pad Frame”
  - Changed pad names for pads 198, 217, 218, 352, 383 in Pad List of “Sequence of Pads in Pad Frame”
  - Changed/ revised footnote for table Pad List of “Sequence of Pads in Pad Frame”
- Changes in chapter “Legend”
    - Changed version number of “TC38xpd\_IO\_Spirit” file
- Changes in chapter “Electrical Specification”
    - Typos corrected in footnotes for sub-chapter “Absolute Maximum Ratings”
    - Typo corrected for parameter  $I_{INSA}$  in table “Overload Parameters” of sub-chapter “Pin Reliability in Overload”
    - Changed values for parameter GETH frequency in table “Operating Conditions”
    - Changed note for parameter  $t_{TX\_ASYM}$  in table “Fast 5V GPIO” of sub-chapter “5V/3.3V switchable Pads”
    - Changed note for parameter  $t_{TX\_ASYM}$  in table “Fast 3.3V GPIO” of sub-chapter “5V/3.3V switchable Pads”
    - Changed note for parameter  $t_{TX\_ASYM}$  in table “Slow 5V GPIO” of sub-chapter “5V/3.3V switchable Pads”
    - Changed note for parameter  $t_{TX\_ASYM}$  in table “Slow 3.3V GPIO” of sub-chapter “5V/3.3V switchable Pads”
    - Changed note for parameter  $t_{TX\_ASYM}$  in table “RFast 5V GPIO” of sub-chapter “5V/3.3V switchable Pads”
    - Changed note for parameter  $t_{TX\_ASYM}$  in table “RFast 3.3V pad” of sub-chapter “5V/3.3V switchable Pads”
    - Changed notes for parameter  $I_{OZ2}$  in table “ADC Reference Pads” of sub-chapter “5V/3.3V switchable Pads”
    - Typos corrected in footnote 3) for table “LVDS – IEEE standard LVDS general purpose link (GPL)” in sub-chapter “High performance LVDS Pads”
    - Added footnote content for table “LVDS – IEEE standard LVDS general purpose link (GPL)” in sub-chapter “High performance LVDS Pads”

**History Changes from Version 1.1 to Version 1.2**

- Typo corrected for parameter  $dV_{\text{CSD}}$  in table “VADC 5V” in sub-chapter “VADC Parameters”
- Changed footnote 7) of table “VADC 5V” in sub-chapter “VADC Parameters”
- Changed figure “Equivalent Circuitry for Analog Inputs” in sub-chapter “VADC Parameters”
- Changed footnotes 3) and 6) for table “VADC 5V” in sub-chapter “VADC Parameters”
- Changed value of parameter  $I_{\text{RMS}}$  in table “DSADC 5V” in sub-chapter “DSADC Parameters”
- Changed footnote 4) in sub-chapter “DSADC Parameters”
- Changed spelling in footnote 2) in sub-chapter “MHz Oscillator”
- Changed spelling in initial text for sub-chapter “Power Supply Current”
- Changed footnote 2) for table “Current Consumption” in sub-chapter “Power Supply Current”
- Added footnote 7) for table “Current Consumption” in sub-chapter “Power Supply Current”
- Typos corrected in sub-chapter “Calculating the 1.25V Current Consumption”
- Added sentence to sub-chapter “Supply Ramp-up and Ramp-down Behavior”
- Changed/added value for parameter  $t_{\text{PI}}$  in table “Reset” for sub-chapter “Reset Timing”
- Changed figure “DAP Timing” in sub-chapter “DAP Parameters”
- Changed values (from Min. to Typ.) for parameter  $t_7$  in table “ETH MII Signal Timing Parameters” for sub-chapter “ETH MII Parameters”
- Changed symbols for parameters  $t_{13}$ ,  $t_{14}$ ,  $t_{15}$  in table “ETH RMII Signal Timing Parameters valid for 3.3V” in sub-chapter “ETH RMII Parameters”
- Changed value (from Min. to Typ.) for parameter  $t_{13}$  in table “ETH RMII Signal Timing Parameters valid for 3.3V” in sub-chapter “ETH RMII Parameters”
- Added footnote 3) for table “ETH RMII Signal Timing Parameters valid for 3.3V” in sub-chapter “ETH RMII Parameters”
- Changed figure title to “Package Outlines FBGA-516” in sub-chapter “Package Outline”
- Changed notes in table “Package Parameters” to “FBGA” for sub-chapter “Package Parameters”
- Deleted sub-chapter “TC380 Carrier Tape”



[www.infineon.com](http://www.infineon.com)

Published by Infineon Technologies AG



OPEN MARKET VERSION

## Looking for pricing, stock, or lifecycle information?

Click below to explore more details on WIN SOURCE:

-  [View SAK-TC387QP-160F300S AE on WIN SOURCE](#)
-  [Infineon Technologies Information](#)

## Optimize Your Supply Chain with WIN SOURCE Solutions

-  Global Sourcing Solution
-  Obsolete Management
-  Cost Control Management
-  Shortage Management
-  Alternative Solution
-  Excess Inventory Management