



LVC MOS/LVTTL-to-Differential 3.3V, 2.5V LVPECL Translator

85320

DATASHEET

GENERAL DESCRIPTION

The 85320I is a LVC MOS / LVTTL-to-Differential 3.3V, 2.5V LVPECL translator. The 85320I has a single ended clock input. The single ended clock input accepts LVC MOS or LVTTL input levels and translates them to 3.3V or 2.5V LVPECL levels. The small outline 8-pin SOIC package makes this device ideal for applications where space, high performance and low power are important.

FEATURES

- One differential 2.5V/3.3V LVPECL output
- LVC MOS/LVTTL CLK input
- CLK accepts the following input levels: LVC MOS or LVTTL
- Maximum output frequency: 267MHz
- Part-to-part skew: 275ps (maximum)
- Additive phase jitter, RMS: 0.05ps (typical)
- 3.3V operating supply voltage (operating range 3.135V to 3.465V)
- 2.5V operating supply voltage (operating range 2.375V to 2.625V)
- -40°C to 85°C ambient operating temperature
- Available in lead-free (RoHS 6) package

BLOCK DIAGRAM



PIN ASSIGNMENT

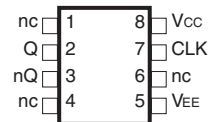

85320I

8-Lead SOIC

3.90mm x 4.92mm x 1.37mm body package

M Package

Top View

TABLE 1. PIN DESCRIPTIONS

Number	Name	Type		Description
1, 4, 6	nc	Unused		No connect.
2,3	Q, nQ	Output		Differential output pair. LVPECL interface levels.
5	V _{EE}	Power		Negative supply pin.
7	CLK	Input	Pullup	LVC MOS / LV TTL clock input.
8	V _{CC}	Power		Positive supply pin.

NOTE: *Pullup* refers to internal input resistors. See Table 2, Pin Characteristics, for typical values.

TABLE 2. PIN CHARACTERISTICS

Symbol	Parameter	Test Conditions	Minimum	Typical	Maximum	Units
C _{IN}	Input Capacitance			4		pF
R _{PULLUP}	Input Pullup Resistor			51		kΩ

ABSOLUTE MAXIMUM RATINGS

Supply Voltage, V_{CC}	4.6V
Inputs, V_I	-0.5V to $V_{CC} + 0.5V$
Outputs, I_O	
Continuous Current	50mA
Surge Current	100mA
Package Thermal Impedance, θ_{JA}	112.7°C/W (0 lfpm)
Storage Temperature, T_{STG}	-65°C to 150°C

NOTE: Stresses beyond those listed under Absolute Maximum Ratings may cause permanent damage to the device. These ratings are stress specifications only. Functional operation of product at these conditions or any conditions beyond those listed in the *DC Characteristics* or *AC Characteristics* is not implied. Exposure to absolute maximum rating conditions for extended periods may affect product reliability.

TABLE 3A. POWER SUPPLY DC CHARACTERISTICS, $V_{CC} = 3.3V \pm 5\%$ OR $2.5V \pm 5\%$, $T_A = -40^\circ C$ TO $85^\circ C$

Symbol	Parameter	Test Conditions	Minimum	Typical	Maximum	Units
V_{CC}	Positive Supply Voltage		3.135	3.3	3.465	V
			2.375	2.5	2.625	V
I_{EE}	Power Supply Current				25	mA

TABLE 3B. LVCMOS / LVTTTL DC CHARACTERISTICS, $V_{CC} = 3.3V \pm 5\%$, $T_A = -40^\circ C$ TO $85^\circ C$

Symbol	Parameter	Test Conditions	Minimum	Typical	Maximum	Units
V_{IH}	Input High Voltage	CLK	2		$V_{CC} + 0.3$	V
V_{IL}	Input Low Voltage	CLK	-0.3		1.3	V
I_{IH}	Input High Current	CLK			5	μA
I_{IL}	Input Low Current	CLK				μA

TABLE 3C. LVCMOS / LVTTTL DC CHARACTERISTICS, $V_{CC} = 2.5V \pm 5\%$, $T_A = -40^\circ C$ TO $85^\circ C$

Symbol	Parameter	Test Conditions	Minimum	Typical	Maximum	Units
V_{IH}	Input High Voltage	CLK	1.6		$V_{CC} + 0.3$	V
V_{IL}	Input Low Voltage	CLK	-0.3		0.9	V
I_{IH}	Input High Current	CLK			5	μA
I_{IL}	Input Low Current	CLK				μA

TABLE 3D. LVPECL DC CHARACTERISTICS, $V_{CC} = 3.3V \pm 5\%$ OR $2.5V \pm 5\%$, $T_A = -40^\circ C$ TO $85^\circ C$

Symbol	Parameter	Test Conditions	Minimum	Typical	Maximum	Units
V_{OH}	Output High Voltage; NOTE 1		$V_{CC} - 1.4$		$V_{CC} - 0.9$	V
V_{OL}	Output Low Voltage; NOTE 1		$V_{CC} - 2.0$		$V_{CC} - 1.7$	V
V_{SWING}	Peak-to-Peak Output Voltage Swing		0.6		1.0	V

NOTE 1: Outputs terminated with 50 Ω to $V_{CC} - 2V$.

TABLE 4A. AC CHARACTERISTICS, $V_{cc} = 3.3V \pm 5\%$, $T_A = -40^\circ C$ TO $85^\circ C$

Symbol	Parameter	Test Conditions	Minimum	Typical	Maximum	Units
f_{MAX}	Output Frequency				267	MHz
t_{PD}	Propagation Delay; NOTE 1	$f \leq 267MHz$	0.8		1.4	ns
tjit	Buffer Additive Phase Jitter, RMS; refer to Additive Phase Jitter Section	Integration Range: 12KHz - 20MHz		0.05		ps
tsk(pp)	Part-to-Part Skew; NOTE 2, 3				275	ps
t_R, t_F	Output Rise/Fall Time	20% to 80%	200		700	ps
odc	Output Duty Cycle		45		55	%

NOTE 1: Measured from $V_{cc}/2$ point of the input to the differential output crossing point.

NOTE 2: Defined as skew between outputs on different devices operating at the same supply voltages and with equal load conditions. Using the same type of inputs on each device, the outputs are measured at the differential cross points.

NOTE 3: This parameter is defined in accordance with JEDEC Standard 65.

TABLE 4B. AC CHARACTERISTICS, $V_{cc} = 2.5V \pm 5\%$, $T_A = -40^\circ C$ TO $85^\circ C$

Symbol	Parameter	Test Conditions	Minimum	Typical	Maximum	Units
f_{MAX}	Output Frequency				215	MHz
t_{PD}	Propagation Delay; NOTE 1	$f \leq 267MHz$	0.8		1.7	ns
tjit	Buffer Additive Phase Jitter, RMS; refer to Additive Phase Jitter Section	Integration Range: 12KHz - 20MHz		0.05		ps
tsk(pp)	Part-to-Part Skew; NOTE 2, 3				375	ps
t_R, t_F	Output Rise/Fall Time	20% to 80%	200		700	ps
odc	Output Duty Cycle		45		55	%

NOTE 1: Measured from $V_{cc}/2$ point of the input to the differential output crossing point.

NOTE 2: Defined as skew between outputs on different devices operating at the same supply voltages and with equal load conditions. Using the same type of inputs on each device, the outputs are measured at the differential cross points.

NOTE 3: This parameter is defined in accordance with JEDEC Standard 65.

ADDITIVE PHASE JITTER

The spectral purity in a band at a specific offset from the fundamental compared to the power of the fundamental is called the **dBc Phase Noise**. This value is normally expressed using a Phase noise plot and is most often the specified plot in many applications. Phase noise is defined as the ratio of the noise power present in a 1Hz band at a specified offset from the fundamental frequency to the power value of the fundamental. This ratio is expressed in decibels (dBm) or a ratio of the power in the 1Hz band to the power in the

fundamental. When the required offset is specified, the phase noise is called a **dBc** value, which simply means dBm at a specified offset from the fundamental. By investigating jitter in the frequency domain, we get a better understanding of its effects on the desired application, we get a better understanding of its effects on the desired application, it is mathematically possible to calculate an expected bit error rate given a phase noise plot.

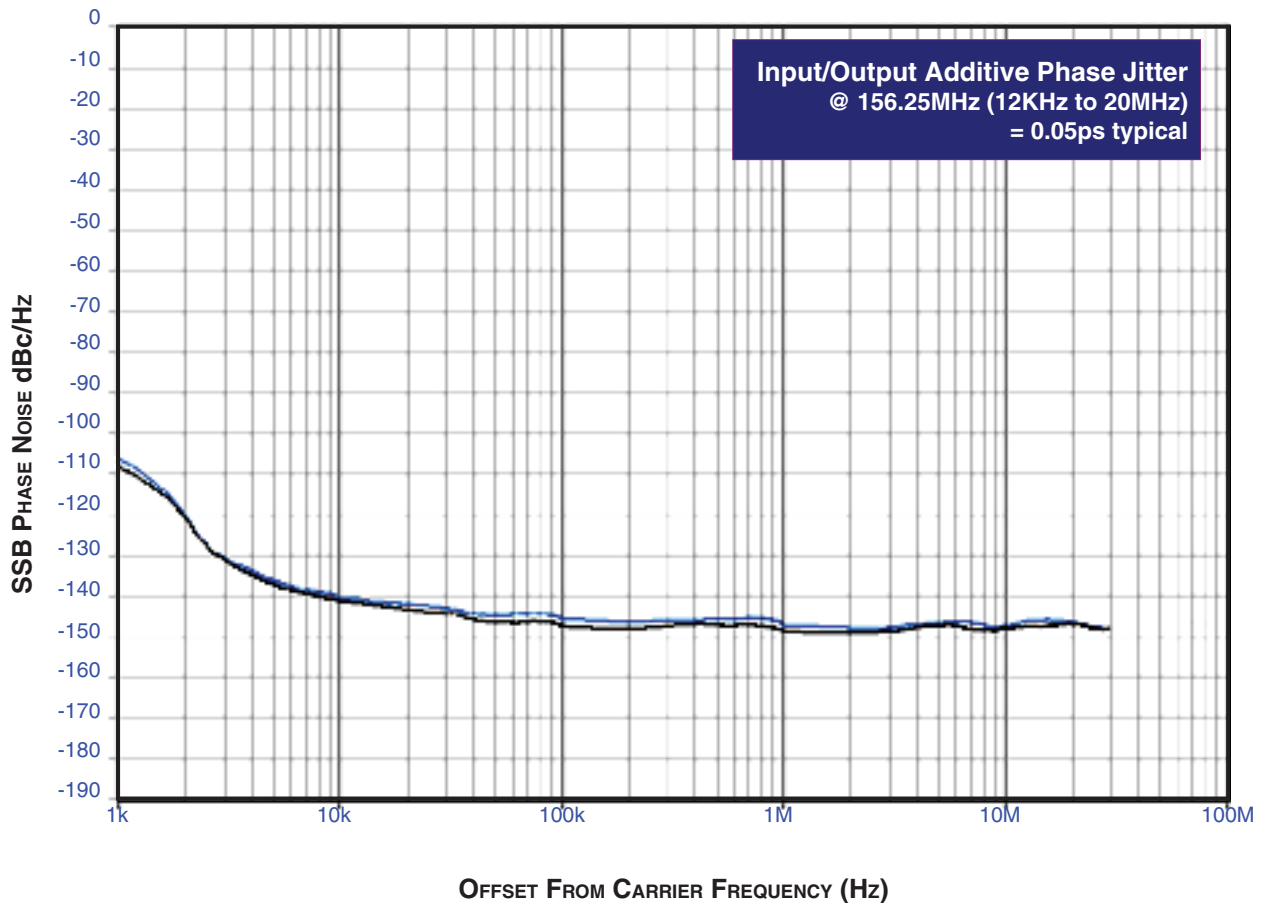

As with most timing specifications, phase noise measurements have issues. The primary issue relates to the limitations of the equipment. Often the noise floor of the equipment is higher than the noise floor of the device. This is illustrated above. The device meets the noise

floor of what is shown, but can actually be lower. The phase noise is dependant on the input source and measurement equipment.

PARAMETER MEASUREMENT INFORMATION

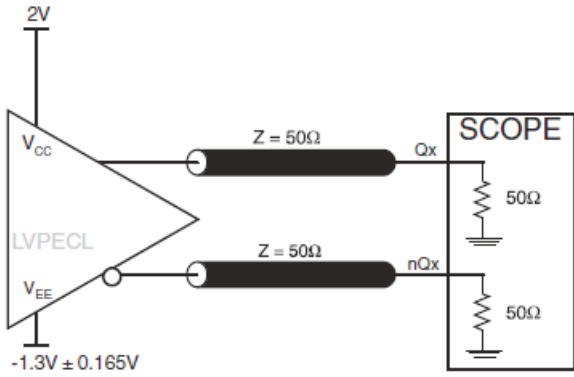

3.3V CORE/3.3V OUTPUT LOAD AC TEST CIRCUIT

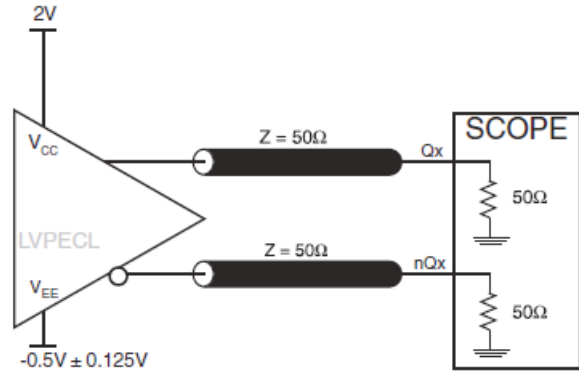

2.5V CORE/2.5V OUTPUT LOAD AC TEST CIRCUIT

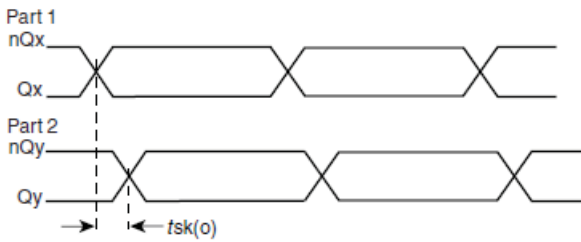

PART-TO-PART SKEW

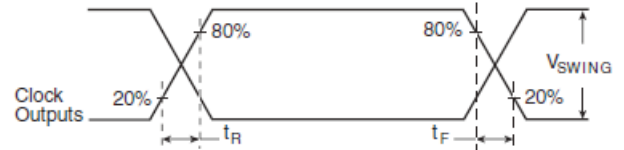

OUTPUT RISE/FALL TIME

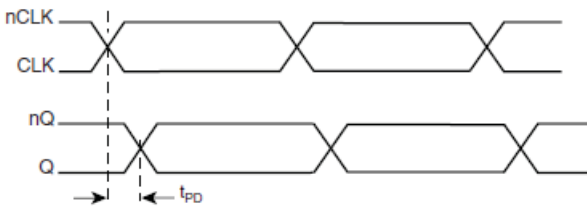

PROPAGATION DELAY

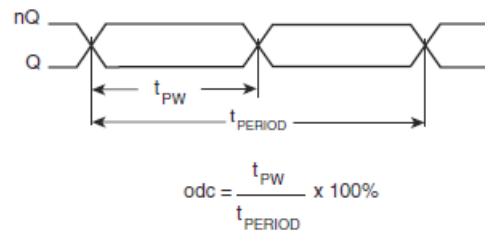

OUTPUT DUTY CYCLE/PULSE WIDTH/PERIOD

APPLICATION INFORMATION

TERMINATION FOR LVPECL OUTPUTS

The clock layout topology shown below is a typical termination for LVPECL outputs. The two different layouts mentioned are recommended only as guidelines.

FOUT and nFOUT are low impedance follower outputs that generate ECL/LVPECL compatible outputs. Therefore, terminating resistors (DC current path to ground) or current sources must be used for functionality. These outputs are designed to drive 50Ω transmission lines. Matched impedance techniques should be used to maximize

operating frequency and minimize signal distortion. *Figures 1A and 1B* show two different layouts which are recommended only as guidelines. Other suitable clock layouts may exist and it would be recommended that the board designers simulate to guarantee compatibility across all printed circuit and clock component process variations.

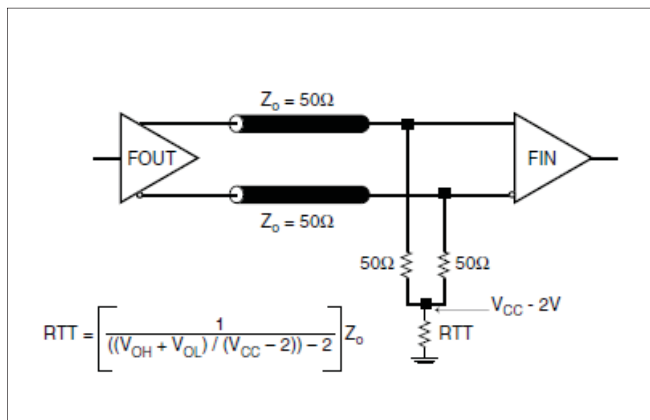

FIGURE 1A. LVPECL OUTPUT TERMINATION

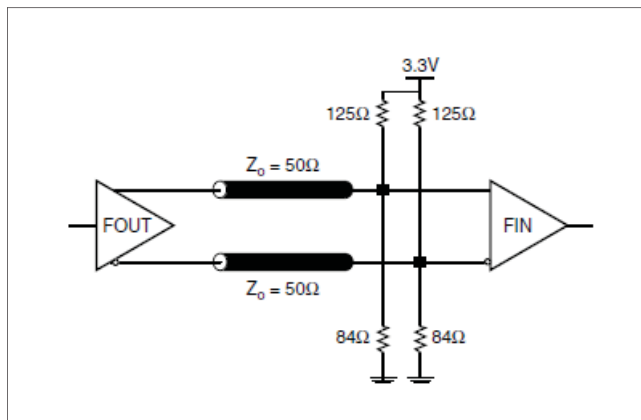

FIGURE 1B. LVPECL OUTPUT TERMINATION

TERMINATION FOR 2.5V LVPECL OUTPUT

Figure 2A and Figure 2B show examples of termination for 2.5V LVPECL driver. These terminations are equivalent to terminating 50Ω to $V_{cc} - 2V$. For $V_{cc} = 2.5V$, the $V_{cc} - 2V$ is very close to ground

level. The R3 in Figure 2B can be eliminated and the termination is shown in Figure 2C.

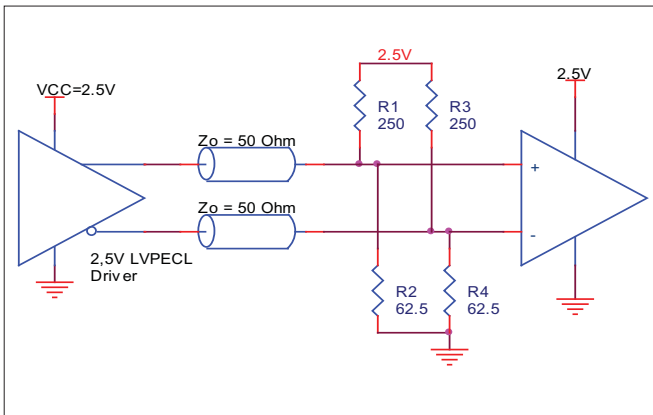

FIGURE 2A. 2.5V LVPECL DRIVER TERMINATION EXAMPLE

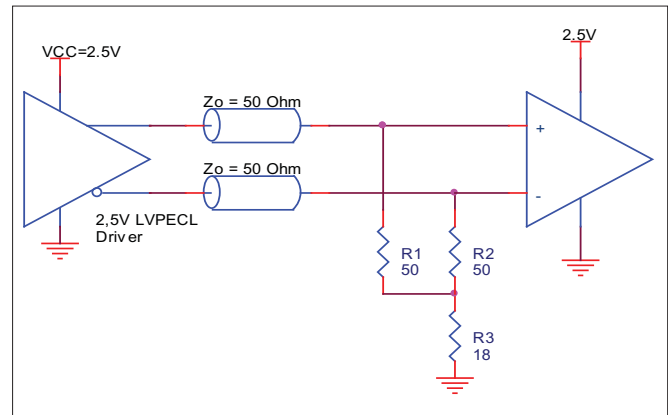

FIGURE 2B. 2.5V LVPECL DRIVER TERMINATION EXAMPLE

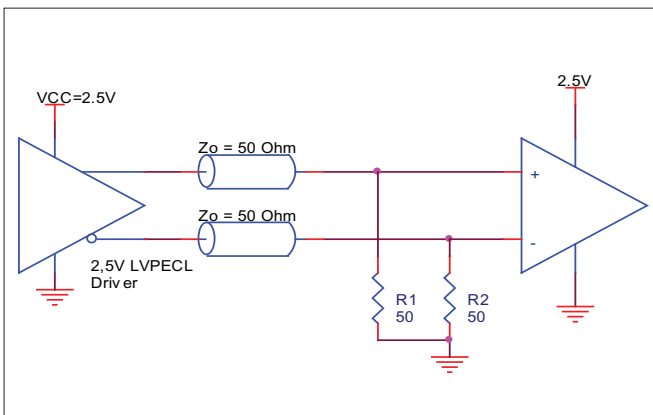

FIGURE 2C. 2.5V LVPECL TERMINATION EXAMPLE

APPLICATION SCHEMATIC EXAMPLE

Figure 3 shows an example of 85320I application schematic. In this example, the device is operated at $V_{cc} = 3.3V$. The decoupling capacitor should be located as close as possible to the power pin. For LVPECL output termination, only two terminations examples are

shown in this schematic. For more termination approaches, please refer to the LVPECL Termination Application Note.

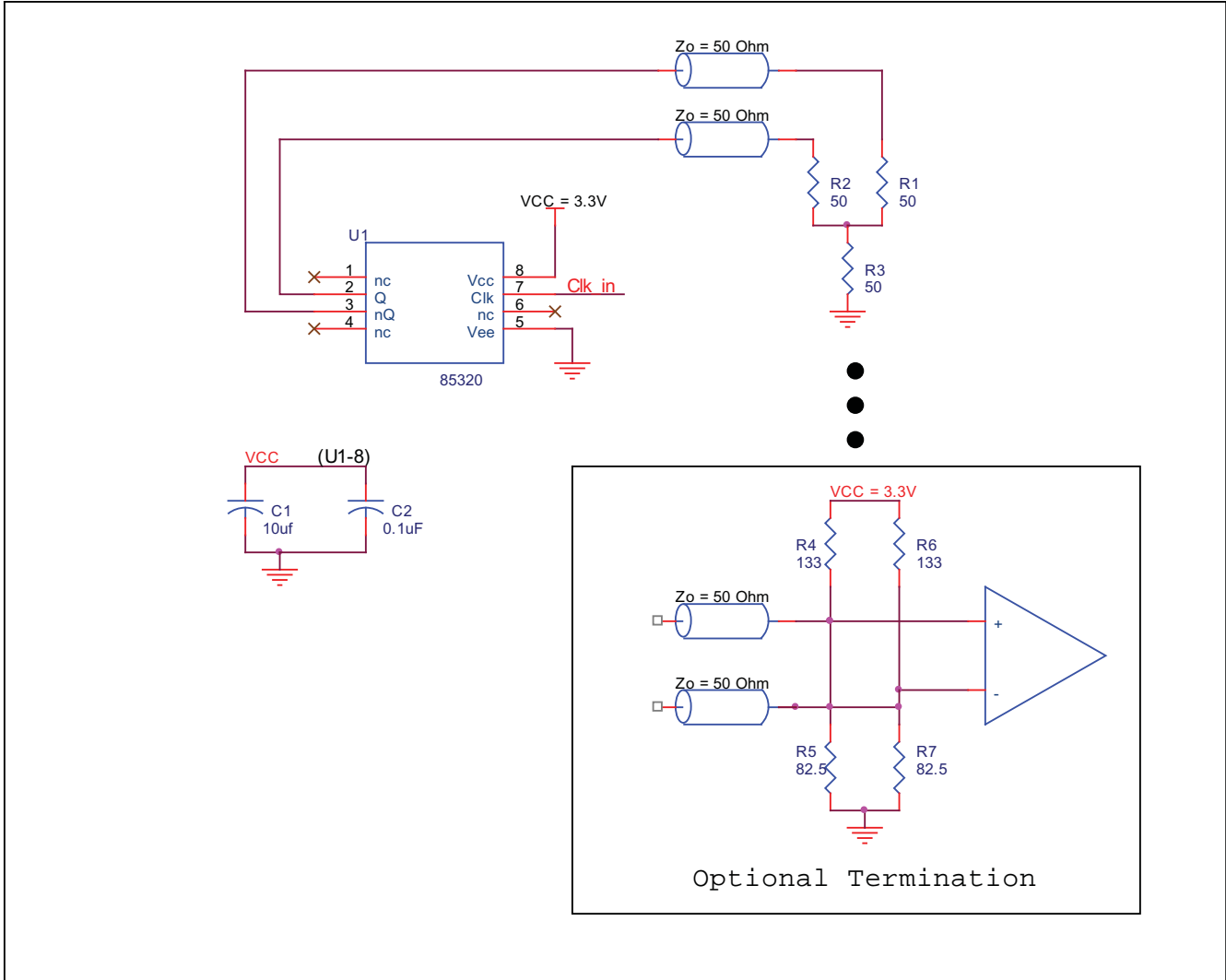

FIGURE 3. 85320I APPLICATION SCHEMATIC EXAMPLE

POWER CONSIDERATIONS

This section provides information on power dissipation and junction temperature for the 85320I. Equations and example calculations are also provided.

1. Power Dissipation.

The total power dissipation for the 85320I is the sum of the core power plus the power dissipated in the load(s). The following is the power dissipation for $V_{CC} = 3.3V + 5\% = 3.465V$, which gives worst case results.

NOTE: Please refer to Section 3 for details on calculating power dissipated in the load.

- Power (core)_{MAX} = $V_{CC_MAX} * I_{EE_MAX} = 3.465V * 25mA = 86.6mW$
- Power (outputs)_{MAX} = **30.2mW/Loaded Output pair**

$$\text{Total Power}_{MAX} (3.465V, \text{ with all outputs switching}) = 86.6mW + 30.2mW = 116.6mW$$

2. Junction Temperature.

Junction temperature, T_j , is the temperature at the junction of the bond wire and bond pad and directly affects the reliability of the device. The maximum recommended junction temperature for HiPerClockS™ devices is 125°C.

The equation for T_j is as follows: $T_j = \theta_{JA} * Pd_total + T_A$

T_j = Junction Temperature

θ_{JA} = Junction-to-Ambient Thermal Resistance

Pd_total = Total Device Power Dissipation (example calculation is in section 1 above)

T_A = Ambient Temperature

In order to calculate junction temperature, the appropriate junction-to-ambient thermal resistance θ_{JA} must be used. Assuming a moderate air flow of 200 linear feet per minute and a multi-layer board, the appropriate value is 103.3°C/W per Table 5 below.

Therefore, T_j for an ambient temperature of 85°C with all outputs switching is:

$$85^\circ\text{C} + 0.117W * 103.3^\circ\text{C/W} = 97.1^\circ\text{C}. \text{ This is well below the limit of } 125^\circ\text{C}.$$

This calculation is only an example. T_j will obviously vary depending on the number of loaded outputs, supply voltage, air flow, and the type of board (single layer or multi-layer).

TABLE 5. THERMAL RESISTANCE θ_{JA} FOR 8-PIN SOIC, FORCED CONVECTION

θ_{JA} by Velocity (Linear Feet per Minute)			
	0	200	500
Single-Layer PCB, JEDEC Standard Test Boards	153.3°C/W	128.5°C/W	115.5°C/W
Multi-Layer PCB, JEDEC Standard Test Boards	112.7°C/W	103.3°C/W	97.1°C/W

NOTE: Most modern PCB designs use multi-layered boards. The data in the second row pertains to most designs.

3. Calculations and Equations.

The purpose of this section is to derive the power dissipated into the load.

LVPECL output driver circuit and termination are shown in *Figure 4*.

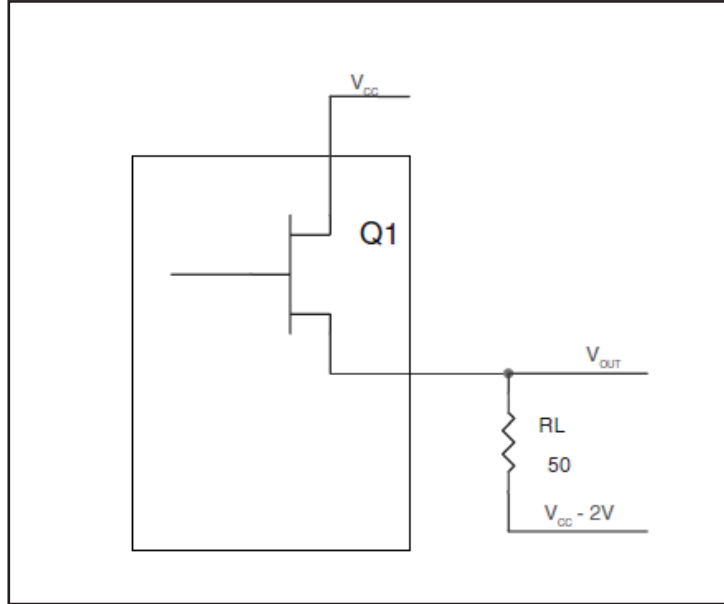

FIGURE 4. LVPECL DRIVER CIRCUIT AND TERMINATION

To calculate worst case power dissipation into the load, use the following equations which assume a 50Ω load, and a termination voltage of $V_{cc} - 2V$.

- For logic high, $V_{OUT} = V_{OH_MAX} = V_{CC_MAX} - 1.0V$

$$(V_{CC_MAX} - V_{OH_MAX}) = 1.0V$$

- For logic low, $V_{OUT} = V_{OL_MAX} = V_{CC_MAX} - 1.7V$

$$(V_{CC_MAX} - V_{OL_MAX}) = 1.7V$$

Pd_H is power dissipation when the output drives high.
Pd_L is the power dissipation when the output drives low.

$$Pd_H = [(V_{OH_MAX} - (V_{CC_MAX} - 2V))/R_L] * (V_{CC_MAX} - V_{OH_MAX}) = [(2V - (V_{CC_MAX} - V_{OH_MAX}))/R_L] * (V_{CC_MAX} - V_{OH_MAX}) = [(2V - 1V)/50\Omega] * 1V = 20.0mW$$

$$Pd_L = [(V_{OL_MAX} - (V_{CC_MAX} - 2V))/R_L] * (V_{CC_MAX} - V_{OL_MAX}) = [(2V - (V_{CC_MAX} - V_{OL_MAX}))/R_L] * (V_{CC_MAX} - V_{OL_MAX}) = [(2V - 1.7V)/50\Omega] * 1.7V = 10.2mW$$

$$\text{Total Power Dissipation per output pair} = Pd_H + Pd_L = 30.2mW$$

RELIABILITY INFORMATION

TABLE 6. θ_{JA} VS. AIR FLOW TABLE FOR 8 LEAD SOIC

θ_{JA} by Velocity (Linear Feet per Minute)			
	0	200	500
Single-Layer PCB, JEDEC Standard Test Boards	153.3°C/W	128.5°C/W	115.5°C/W
Multi-Layer PCB, JEDEC Standard Test Boards	112.7°C/W	103.3°C/W	97.1°C/W

NOTE: Most modern PCB designs use multi-layered boards. The data in the second row pertains to most designs.

TRANSISTOR COUNT

The transistor count for 85320I is: 269

PACKAGE OUTLINE - M SUFFIX FOR 8 LEAD SOIC

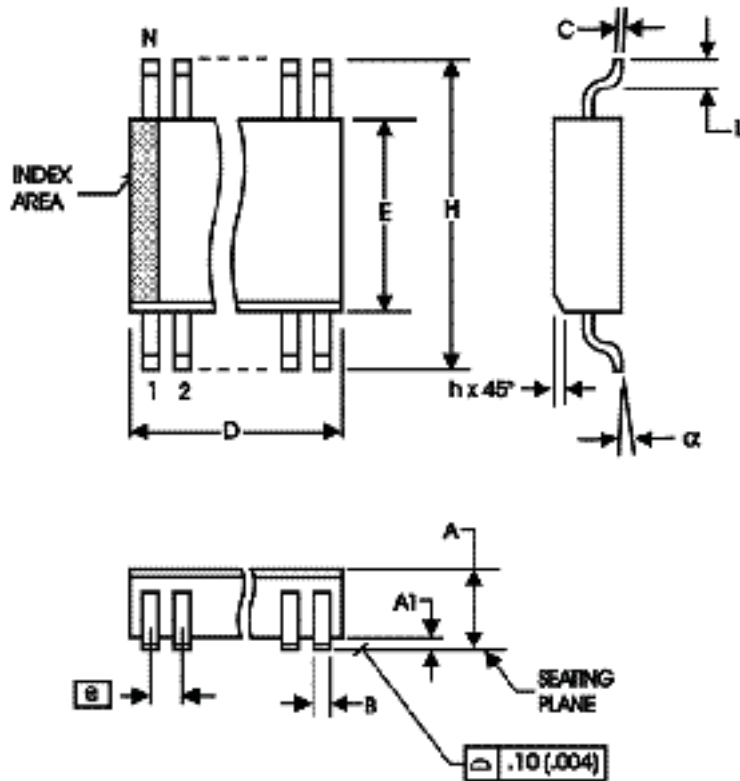

TABLE 7. PACKAGE DIMENSIONS

SYMBOL	Millimeters	
	MINIMUM	MAXIMUM
N	8	
A	1.35	1.75
A1	0.10	0.25
B	0.33	0.51
C	0.19	0.25
D	4.80	5.00
E	3.80	4.00
e	1.27 BASIC	
H	5.80	6.20
h	0.25	0.50
L	0.40	1.27
α	0°	8°

Reference Document: JEDEC Publication 95, MS-012

TABLE 8. ORDERING INFORMATION

Part/Order Number	Marking	Package	Shipping Packaging	Temperature
ICS85320AMILF	85320AIL	8 lead "Lead-Free" SOIC	tube	-40°C to 85°C
ICS85320AMILFT	85320AIL	8 lead "Lead-Free" SOIC	tape & reel	-40°C to 85°C

NOTE: Parts that are ordered with an "LF" suffix to the part number are the Pb-Free configuration and are RoHS compliant.

REVISION HISTORY SHEET				
Rev	Table	Page	Description of Change	Date
A		1	Features Section - added lead-free bullet.	11/13/06
		14	Ordering Information Table - corrected standard marking and, added lead-free part number, marking, and note. Updated datasheet layout.	
B	T8	14	Ordering information - removed leaded devices. PDN CQ-13-02 Updated datasheet format	12/19/14

**Corporate Headquarters**

6024 Silver Creek Valley Road
San Jose, California 95138

Sales

800-345-7015 or +408-284-8200
Fax: 408-284-2775
www.IDT.com

Technical Support

email: clocks@idt.com

DISCLAIMER Integrated Device Technology, Inc. (IDT) and its subsidiaries reserve the right to modify the products and/or specifications described herein at any time and at IDT's sole discretion. All information in this document, including descriptions of product features and performance, is subject to change without notice. Performance specifications and the operating parameters of the described products are determined in the independent state and are not guaranteed to perform the same way when installed in customer products. The information contained herein is provided without representation or warranty of any kind, whether express or implied, including, but not limited to, the suitability of IDT's products for any particular purpose, an implied warranty of merchantability, or non-infringement of the intellectual property rights of others. This document is presented only as a guide and does not convey any license under intellectual property rights of IDT or any third parties.

IDT's products are not intended for use in applications involving extreme environmental conditions or in life support systems or similar devices where the failure or malfunction of an IDT product can be reasonably expected to significantly affect the health or safety of users. Anyone using an IDT product in such a manner does so at their own risk, absent an express, written agreement by IDT.

Integrated Device Technology, IDT and the IDT logo are registered trademarks of IDT. Other trademarks and service marks used herein, including protected names, logos and designs, are the property of IDT or their respective third party owners.

Copyright 2014. All rights reserved.

Looking for pricing, stock, or lifecycle information?

Click below to explore more details on WIN SOURCE:

- ⊖ [View ICS85320AMILFT on WIN SOURCE](#)
- ⊖ [IDT, Integrated Device Technology Inc Information](#)

Optimize Your Supply Chain with WIN SOURCE Solutions

- ✓ Global Sourcing Solution
- ✓ Obsolete Management
- ✓ Cost Control Management
- ✓ Shortage Management
- ✓ Alternative Solution
- ✓ Excess Inventory Management