



**THE DATASHEET OF
ICS8523BGLFT**



LOW SKEW, 1-TO-4 DIFFERENTIAL-TO-HSTL FANOUT BUFFER

ICS8523

GENERAL DESCRIPTION



The ICS8523 is a low skew, high performance 1-to-4 Differential-to-HSTL fanout buffer and a member of the HiPerClockS™ family of High Performance Clock Solutions from ICS. The ICS8523 has two selectable clock inputs. The CLK, nCLK pair can accept most standard differential input levels. The PCLK, nPCLK pair can accept LVPECL, CML, or SSTL input levels. The clock enable is internally synchronized to eliminate runt pulses on the outputs during asynchronous assertion/deassertion of the clock enable pin.

Guaranteed output and part-to-part skew characteristics make the ICS8523 ideal for those applications demanding well defined performance and repeatability.

FEATURES

- 4 differential HSTL compatible outputs
- Selectable differential CLK, nCLK or LVPECL clock inputs
- CLK, nCLK pair can accept the following differential input levels: LVDS, LVPECL, HSTL, SSTL, HCSL
- PCLK, nPCLK supports the following input types: LVPECL, CML, SSTL
- Maximum output frequency: 650MHz
- Translates any single-ended input signal to HSTL levels with resistor bias on nCLK input
- Output skew: 30ps (maximum)
- Part-to-part skew: 200ps (maximum)
- Propagation delay: 1.6ns (maximum)
- 3.3V core, 1.8V output operating supply
- 0°C to 70°C ambient operating temperature
- Lead-Free package available
- Industrial temperature information available upon request

BLOCK DIAGRAM

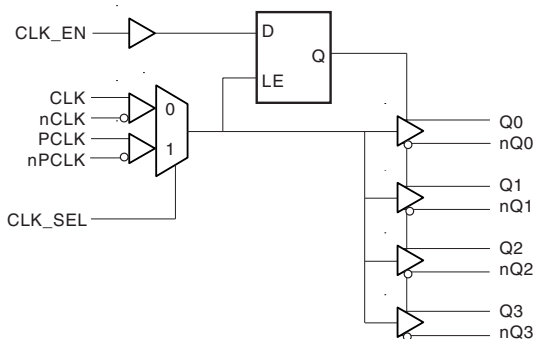

PIN ASSIGNMENT

GND	1	20	Q0
CLK_EN	2	19	nQ0
CLK_SEL	3	18	V _{DDO}
CLK	4	17	Q1
nCLK	5	16	nQ1
PCLK	6	15	Q2
nPCLK	7	14	nQ2
nc	8	13	V _{DDO}
nc	9	12	Q3
V _{DD}	10	11	nQ3

ICS8523
20-Lead TSSOP
 6.5mm x 4.4mm x 0.92mm body package
G Package
 Top View

TABLE 1. PIN DESCRIPTIONS

Number	Name	Type		Description
1	GND	Power		Power supply ground.
2	CLK_EN	Input	Pullup	Synchronizing clock enable. When HIGH, clock outputs follow clock input. When LOW, Q outputs are forced low, nQ outputs are forced high. LVCMOS / LVTTTL interface levels.
3	CLK_SEL	Input	Pulldown	Clock select input. When HIGH, selects differential PCLK, nPCLK inputs. When LOW, selects CLK, nCLK inputs. LVCMOS / LVTTTL interface levels.
4	CLK	Input	Pulldown	Non-inverting differential clock input.
5	nCLK	Input	Pullup	Inverting differential clock input.
6	PCLK	Input	Pulldown	Non-inverting differential LVPECL clock input.
7	nPCLK	Input	Pullup	Inverting differential LVPECL clock input.
8, 9	nc	Unused		No connect.
10	V _{DD}	Power		Core supply pin.
11, 12	nQ3, Q3	Output		Differential output pair. HSTL interface levels.
13, 18	V _{DDO}	Power		Output supply pins.
14, 15	nQ2, Q2	Output		Differential output pair. HSTL interface levels.
16, 17	nQ1, Q1	Output		Differential output pair. HSTL interface levels.
19, 20	nQ0, Q0	Output		Differential output pair. HSTL interface levels.

NOTE: *Pullup* and *Pulldown* refer to internal input resistors. See Table 2, Pin Characteristics, for typical values.

TABLE 2. PIN CHARACTERISTICS

Symbol	Parameter	Test Conditions	Minimum	Typical	Maximum	Units
C _{IN}	Input Capacitance			4		pF
R _{PULLUP}	Input Pullup Resistor			51		KΩ
R _{PULLDOWN}	Input Pulldown Resistor			51		KΩ

TABLE 3A. CONTROL INPUT FUNCTION TABLE

Inputs			Outputs	
CLK_EN	CLK_SEL	Selected Source	Q0:Q3	nQ0:nQ3
0	0	CLK, nCLK	Disabled; LOW	Disabled; HIGH
0	1	PCLK, nPCLK	Disabled; LOW	Disabled; HIGH
1	0	CLK, nCLK	Enabled	Enabled
1	1	PCLK, nPCLK	Enabled	Enabled

After CLK_EN switches, the clock outputs are disabled or enabled following a rising and falling input clock edge as shown in Figure 1.

In the active mode, the state of the outputs are a function of the CLK, nCLK and PCLK, nPCLK inputs as described in Table 3B.

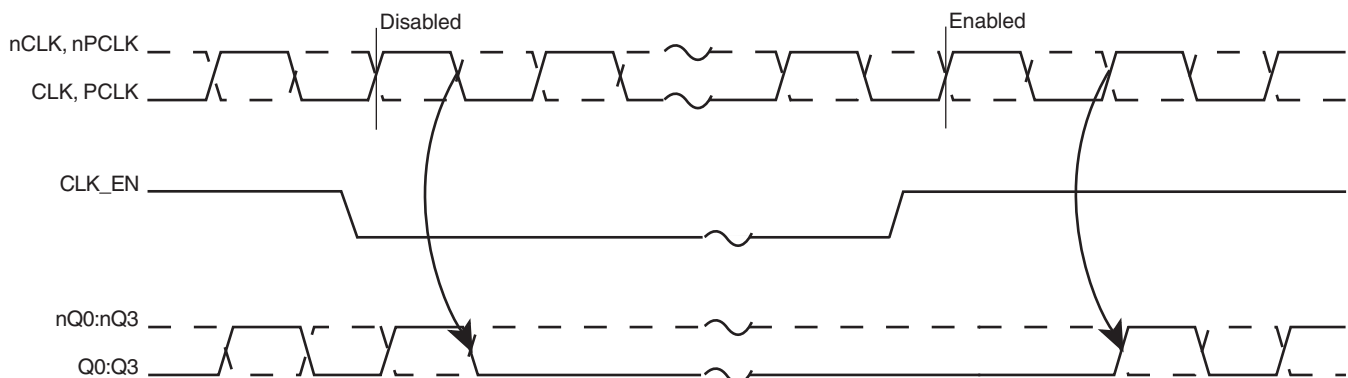

FIGURE 1. CLK_EN TIMING DIAGRAM

TABLE 3B. CLOCK INPUT FUNCTION TABLE

Inputs		Outputs		Input to Output Mode	Polarity
CLK or PCLK	nCLK or nPCLK	Q0:Q3	nQ0:nQ3		
0	0	LOW	HIGH	Differential to Differential	Non Inverting
1	1	HIGH	LOW	Differential to Differential	Non Inverting
0	Biased; NOTE 1	LOW	HIGH	Single Ended to Differential	Non Inverting
1	Biased; NOTE 1	HIGH	LOW	Single Ended to Differential	Non Inverting
Biased; NOTE 1	0	HIGH	LOW	Single Ended to Differential	Inverting
Biased; NOTE 1	1	LOW	HIGH	Single Ended to Differential	Inverting

NOTE 1: Please refer to the Application Information section, "Wiring the Differential Input to Accept Single Ended Levels".

ABSOLUTE MAXIMUM RATINGS

Supply Voltage, V_{DD}	4.6V
Inputs, V_I	-0.5V to $V_{DD} + 0.5V$
Outputs, I_O	
Continuous Current	50mA
Surge Current	100mA
Package Thermal Impedance, θ_{JA}	73.2°C/W (0 lfpm)
Storage Temperature, T_{STG}	-65°C to 150°C

NOTE: Stresses beyond those listed under Absolute Maximum Ratings may cause permanent damage to the device. These ratings are stress specifications only. Functional operation of product at these conditions or any conditions beyond those listed in the *DC Characteristics* or *AC Characteristics* is not implied. Exposure to absolute maximum rating conditions for extended periods may affect product reliability.

TABLE 4A. POWER SUPPLY DC CHARACTERISTICS, $V_{DD} = 3.3V \pm 5\%$, $V_{DDO} = 1.8V \pm 0.2V$, $T_A = 0^\circ C$ TO $70^\circ C$

Symbol	Parameter	Test Conditions	Minimum	Typical	Maximum	Units
V_{DD}	Core Power Supply Voltage		3.135	3.3	3.465	V
V_{DDO}	Output Power Supply Voltage		1.6	1.8	2.0	V
I_{DD}	Power Supply Current				50	mA

TABLE 4B. LVCMOS / LVTTTL DC CHARACTERISTICS, $V_{DD} = 3.3V \pm 5\%$, $V_{DDO} = 1.8V \pm 0.2V$, $T_A = 0^\circ C$ TO $70^\circ C$

Symbol	Parameter	Test Conditions	Minimum	Typical	Maximum	Units
V_{IH}	Input High Voltage	CLK_EN, CLK_SEL	2		$V_{DD} + 0.3$	V
V_{IL}	Input Low Voltage	CLK_EN, CLK_SEL	-0.3		0.8	V
I_{IH}	Input High Current	CLK_EN	$V_{DD} = V_{IN} = 3.465V$		5	μA
		CLK_SEL	$V_{DD} = V_{IN} = 3.465V$		150	μA
I_{IL}	Input Low Current	CLK_EN	$V_{DD} = 3.465V, V_{IN} = 0V$	-150		μA
		CLK_SEL	$V_{DD} = 3.465V, V_{IN} = 0V$	-5		μA

TABLE 4C. DIFFERENTIAL DC CHARACTERISTICS, $V_{DD} = 3.3V \pm 5\%$, $V_{DDO} = 1.8V \pm 0.2V$, $T_A = 0^\circ C$ TO $70^\circ C$

Symbol	Parameter	Test Conditions	Minimum	Typical	Maximum	Units
I_{IH}	Input High Current	nCLK	$V_{DD} = V_{IN} = 3.465V$		5	μA
		CLK	$V_{DD} = V_{IN} = 3.465V$		150	μA
I_{IL}	Input Low Current	nCLK	$V_{DD} = 3.465V, V_{IN} = 0V$	-150		μA
		CLK	$V_{DD} = 3.465V, V_{IN} = 0V$	-5		μA
V_{PP}	Peak-to-Peak Input Voltage		0.15		1.3	V
V_{CMR}	Common Mode Input Voltage; NOTE 1, 2		0.5		$V_{DD} - 0.85$	V

NOTE 1: For single ended applications the maximum input voltage for CLK and nCLK is $V_{DD} + 0.3V$.

NOTE 2: Common mode voltage is defined as V_{IH} .

TABLE 4D. LVPECL DC CHARACTERISTICS, $V_{DD} = 3.3V \pm 5\%$, $V_{DDO} = 1.8V \pm 0.2V$, $T_A = 0^\circ C$ TO $70^\circ C$

Symbol	Parameter	Test Conditions	Minimum	Typical	Maximum	Units
I_{IH}	Input High Current	PCLK	$V_{DD} = V_{IN} = 3.465V$		150	μA
		nPCLK	$V_{DD} = V_{IN} = 3.465V$		5	μA
I_{IL}	Input Low Current	PCLK	$V_{DD} = 3.465V, V_{IN} = 0V$	-5		μA
		nPCLK	$V_{DD} = 3.465V, V_{IN} = 0V$	-150		μA
V_{PP}	Peak-to-Peak Input Voltage		0.3		1	V
V_{CMR}	Common Mode Input Voltage; NOTE 1, 2		1.5		V_{DD}	V

NOTE 1: Common mode voltage is defined as V_{IH} .

NOTE 2: For single ended applications the maximum input voltage for PCLK and nPCLK is $V_{DD} + 0.3V$.

TABLE 4D. HSTL DC CHARACTERISTICS, $V_{DD} = 3.3V \pm 5\%$, $V_{DDO} = 1.8V \pm 0.2V$, $T_A = 0^\circ C$ TO $70^\circ C$

Symbol	Parameter	Test Conditions	Minimum	Typical	Maximum	Units
V_{OH}	Output High Voltage; NOTE 1		0.9		1.4	V
V_{OL}	Output Low Voltage; NOTE 1		0		0.4	V
V_{OX}	Output Crossover Voltage		$40\% \times (V_{OH} - V_{OL}) + V_{OL}$		$60\% \times (V_{OH} - V_{OL}) + V_{OL}$	V
V_{SWING}	Peak-to-Peak Output Voltage Swing		0.75		1.25	V

NOTE 1: Outputs terminated with 50Ω to ground.

TABLE 5. AC CHARACTERISTICS, $V_{DD} = 3.3V \pm 5\%$, $V_{DDO} = 1.8V \pm 0.2V$, $T_A = 0^\circ C$ TO $70^\circ C$

Symbol	Parameter	Test Conditions	Minimum	Typical	Maximum	Units
f_{MAX}	Output Frequency				650	MHz
t_{PD}	Propagation Delay; NOTE 1	$f \leq 650MHz$	1.0		1.6	ns
$t_{sk(o)}$	Output Skew; NOTE 2, 4				30	ps
$t_{sk(pp)}$	Part-to-Part Skew; NOTE 3, 4				200	ps
t_R	Output Rise Time	20% to 80% @ 50MHz	300		700	ps
t_F	Output Fall Time	20% to 80% @ 50MHz	300		700	ps
odc	Output Duty Cycle		45		55	%

All parameters measured at 500MHz unless noted otherwise.

The cycle to cycle jitter on the input will equal the jitter on the output. The part does not add jitter.

NOTE 1: Measured from the differential input crossing point to the differential output crossing point.

NOTE 2: Defined as skew between outputs at the same supply voltage and with equal load conditions.

Measured at output differential cross points.

NOTE 3: Defined as skew between outputs on different devices operating at the same supply voltages and with equal load conditions. Using the same type of inputs on each device, the outputs are measured at the differential cross points.

NOTE 4: This parameter is defined in accordance with JEDEC Standard 65.

PARAMETER MEASUREMENT INFORMATION

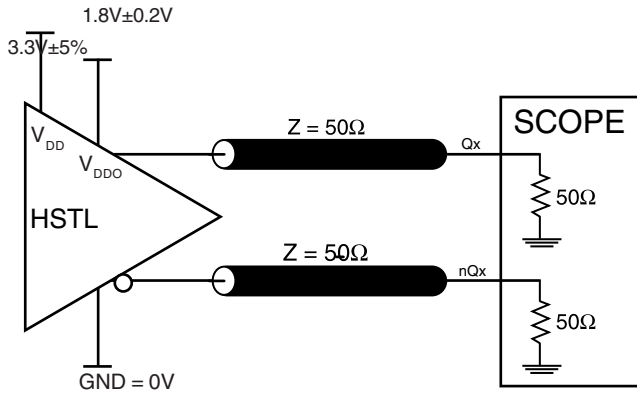

3.3V/1.8V OUTPUT LOAD AC TEST CIRCUIT

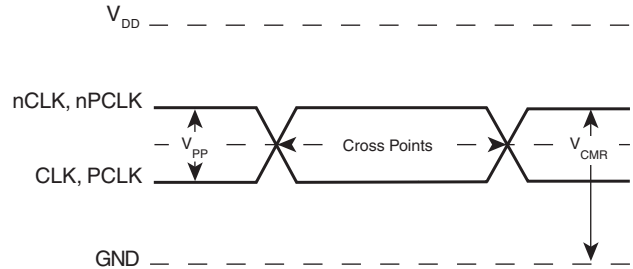

DIFFERENTIAL INPUT LEVEL

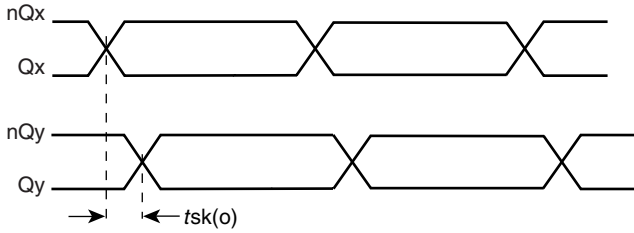

OUTPUT SKEW

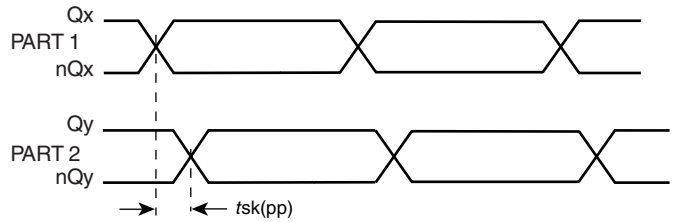

PART-TO-PART SKEW

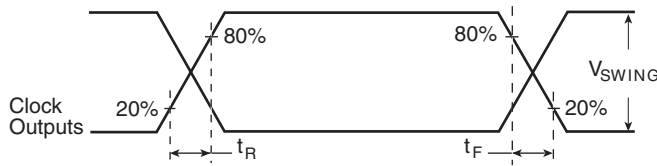

OUTPUT RISE/FALL TIME

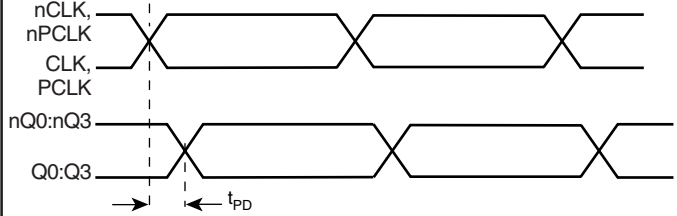

PROPAGATION DELAY

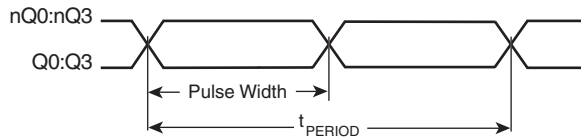

$$odc = \frac{t_{PW}}{t_{PERIOD}}$$

odc & t_{PERIOD}

APPLICATION INFORMATION

WIRING THE DIFFERENTIAL INPUT TO ACCEPT SINGLE ENDED LEVELS

Figure 2 shows how the differential input can be wired to accept single ended levels. The reference voltage $V_{REF} = V_{DD}/2$ is generated by the bias resistors R1, R2 and C1. This bias circuit should be located as close as possible to the input pin. The ratio

of R1 and R2 might need to be adjusted to position the V_{REF} in the center of the input voltage swing. For example, if the input clock swing is only 2.5V and $V_{DD} = 3.3V$, V_{REF} should be 1.25V and $R2/R1 = 0.609$.

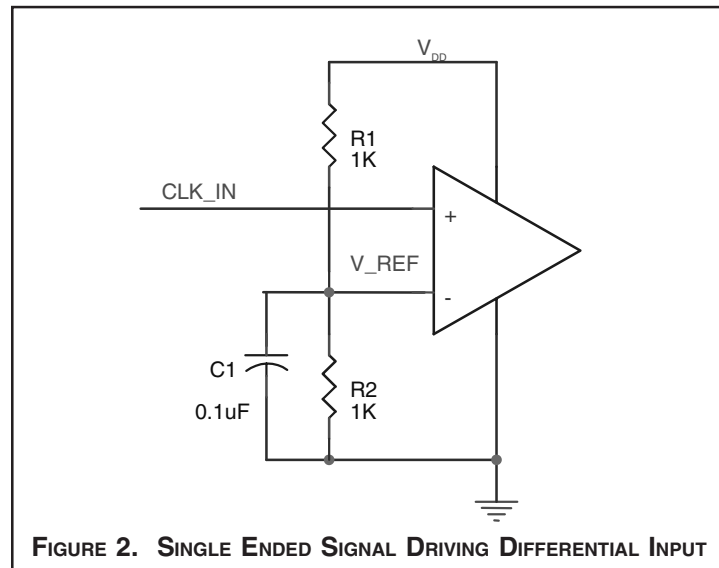

FIGURE 2. SINGLE ENDED SIGNAL DRIVING DIFFERENTIAL INPUT

DIFFERENTIAL CLOCK INPUT INTERFACE

The CLK /nCLK accepts LVDS, LVPECL, HSTL, SSTL, HCSL and other differential signals. Both V_{SWING} and V_{OH} must meet the V_{PP} and V_{CMR} input requirements. Figures 3A to 3E show interface examples for the HiPerClockS CLK/nCLK input driven by the most common driver types. The input interfaces suggested

here are examples only. Please consult with the vendor of the driver component to confirm the driver termination requirements. For example in *Figure 3A*, the input termination applies for ICS HiPerClockS HSTL drivers. If you are using an HSTL driver from another vendor, use their termination recommendation.

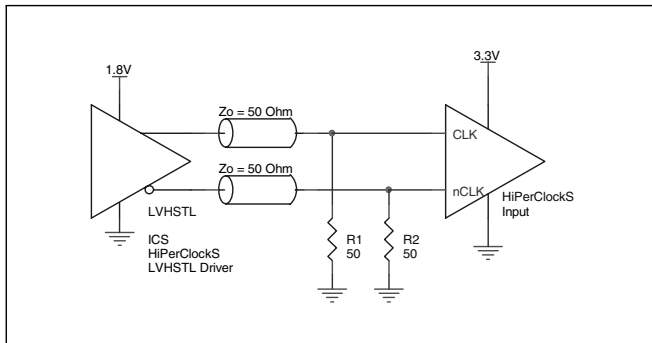

FIGURE 3A. HiPerClockS CLK/nCLK INPUT DRIVEN BY ICS HiPerClockS HSTL DRIVER

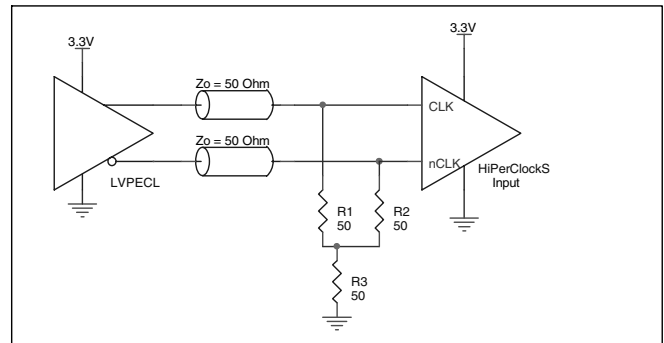

FIGURE 3B. HiPerClockS CLK/nCLK INPUT DRIVEN BY 3.3V LVPECL DRIVER

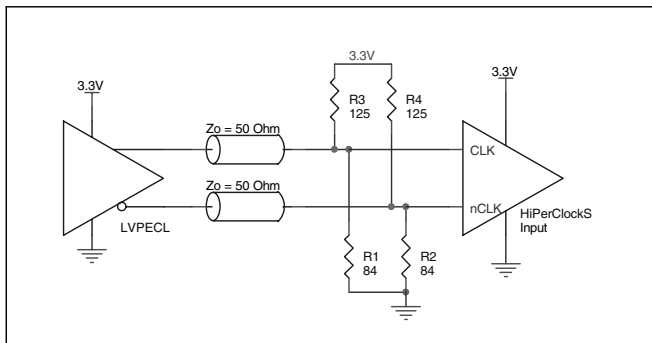

FIGURE 3C. HiPerClockS CLK/nCLK INPUT DRIVEN BY 3.3V LVPECL DRIVER

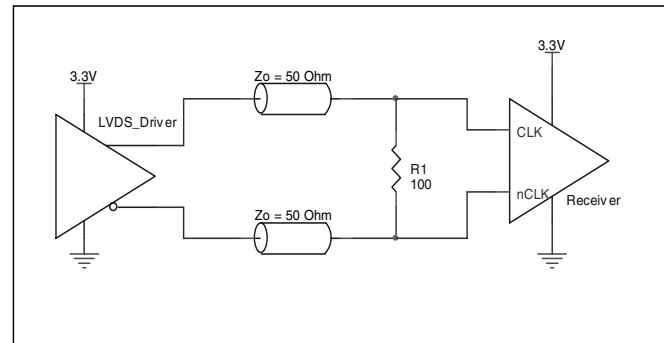

FIGURE 3D. HiPerClockS CLK/nCLK INPUT DRIVEN BY 3.3V LVDS DRIVER

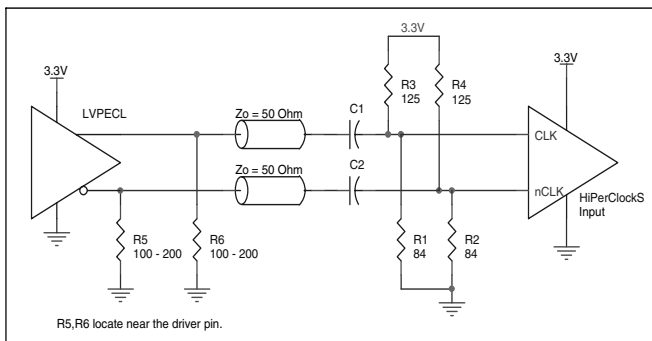

FIGURE 3E. HiPerClockS CLK/nCLK INPUT DRIVEN BY 3.3V LVPECL DRIVER WITH AC COUPLE

LVPECL CLOCK INPUT INTERFACE

The PCLK /nPCLK accepts LVPECL, CML, SSTL and other differential signals. Both V_{SWING} and V_{OH} must meet the V_{PP} and V_{CMR} input requirements. Figures 4A to 4F show interface examples for the HiPerClockS PCLK/nPCLK input driven by the most common driver types. The input interfaces suggested

here are examples only. If the driver is from another vendor, use their termination recommendation. Please consult with the vendor of the driver component to confirm the driver termination requirements.

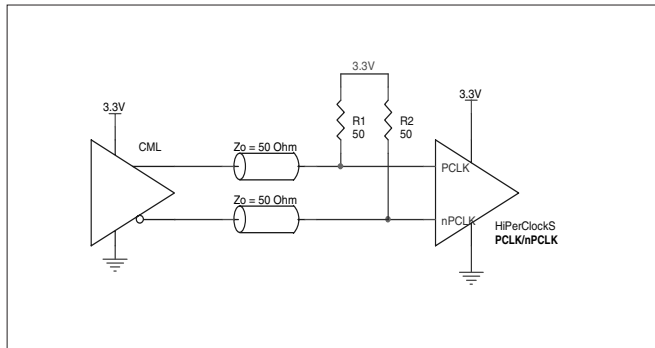

FIGURE 4A. HiPerClockS PCLK/nPCLK INPUT DRIVEN BY AN OPEN COLLECTOR CML DRIVER

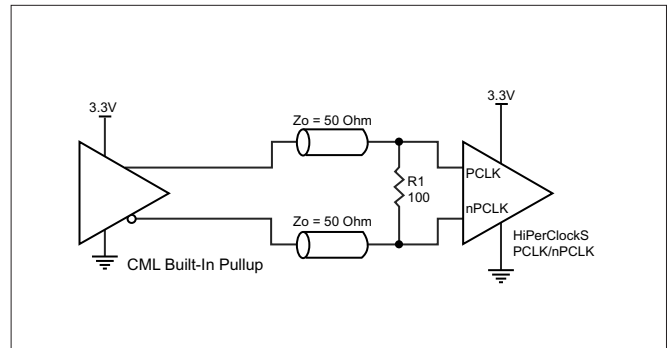

FIGURE 4B. HiPerClockS PCLK/nPCLK INPUT DRIVEN BY A BUILT-IN PULLUP CML DRIVER

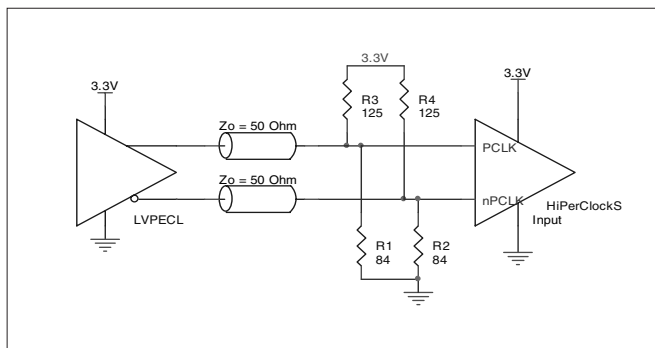

FIGURE 4C. HiPerClockS PCLK/nPCLK INPUT DRIVEN BY A 3.3V LVPECL DRIVER

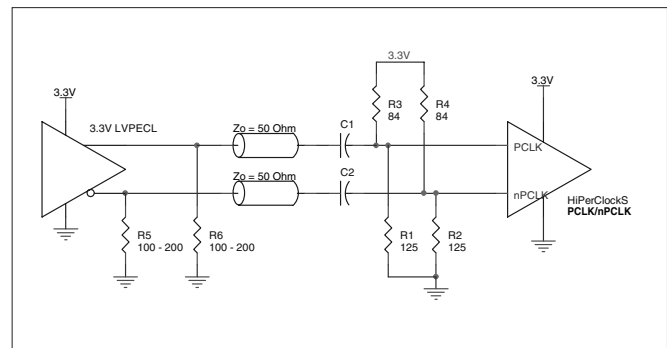

FIGURE 4D. HiPerClockS PCLK/nPCLK INPUT DRIVEN BY A 3.3V LVPECL DRIVER WITH AC COUPLE

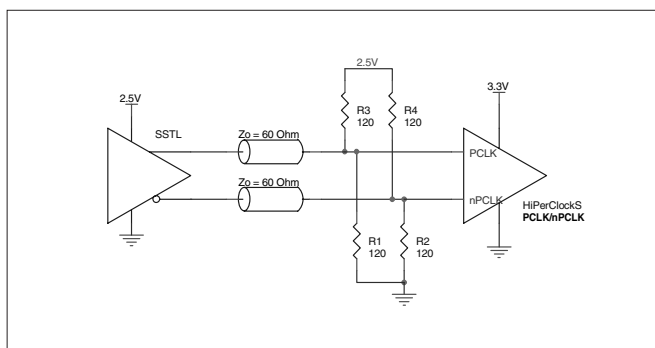

FIGURE 4E. HiPerClockS PCLK/nPCLK INPUT DRIVEN BY AN SSTL DRIVER

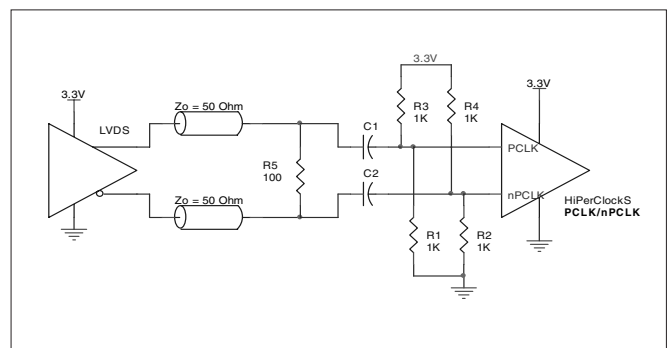

FIGURE 4F. HiPerClockS PCLK/nPCLK INPUT DRIVEN BY A 3.3V LVDS DRIVER

SCHEMATIC EXAMPLE

Figure 5 shows a schematic example of the ICS8523. In this example, the input is driven by an ICS HiPerClockS HSTL driver. The decoupling capacitors should be physically located near the

power pin. For ICS8523, the unused clock outputs can be left floating.

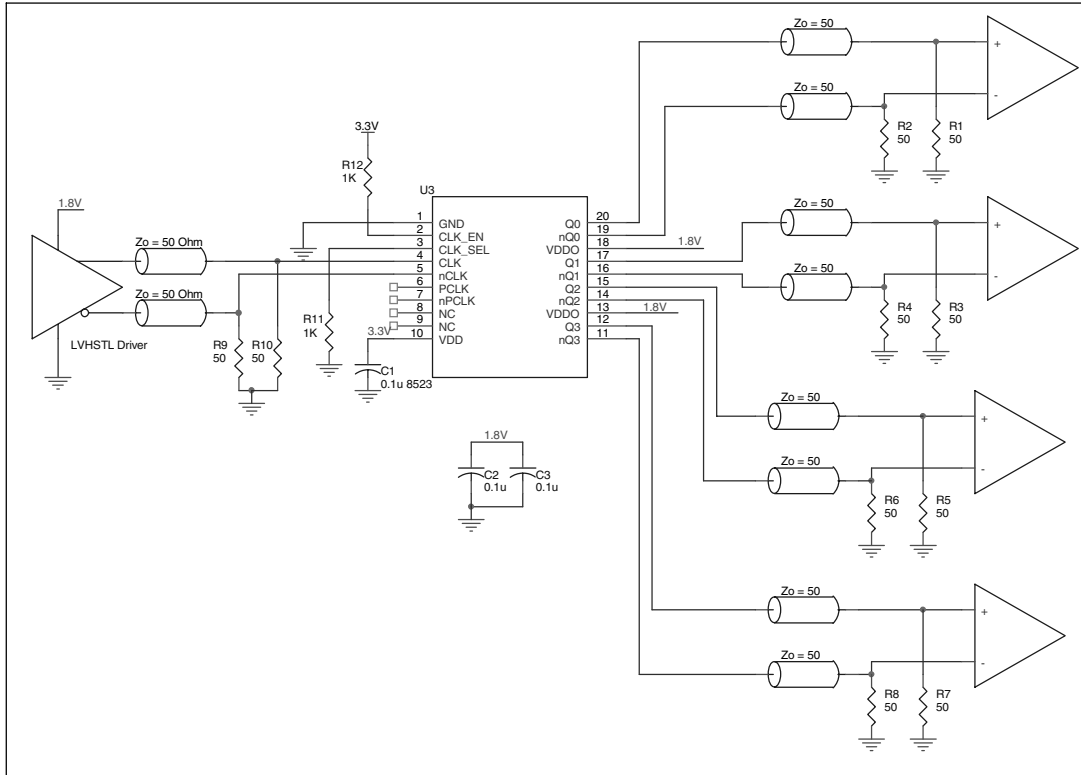

FIGURE 5. ICS8523 HSTL BUFFER SCHEMATIC EXAMPLE

POWER CONSIDERATIONS

This section provides information on power dissipation and junction temperature for the ICS8523. Equations and example calculations are also provided.

1. Power Dissipation.

The total power dissipation for the ICS8523 is the sum of the core power plus the power dissipated in the load(s). The following is the power dissipation for $V_{DD} = 3.3V + 5\% = 3.465V$, which gives worst case results.

NOTE: Please refer to Section 3 for details on calculating power dissipated in the load.

- Power (core)_{MAX} = $V_{DD_MAX} * I_{DD_MAX} = 3.465V * 50mA = 173.3mW$
- Power (outputs)_{MAX} = **32.6mW/Loaded Output pair**
If all outputs are loaded, the total power is $4 * 32.6mW = 130.4mW$

$$\text{Total Power}_{MAX} (3.465V, \text{ with all outputs switching}) = 173.3mW + 130.4mW = 303.7mW$$

2. Junction Temperature.

Junction temperature, T_j , is the temperature at the junction of the bond wire and bond pad and directly affects the reliability of the device. The maximum recommended junction temperature for HiPerClockS™ devices is 125°C.

The equation for T_j is as follows: $T_j = \theta_{JA} * Pd_total + T_A$

T_j = Junction Temperature

θ_{JA} = Junction-to-Ambient Thermal Resistance

Pd_total = Total Device Power Dissipation (example calculation is in section 1 above)

T_A = Ambient Temperature

In order to calculate junction temperature, the appropriate junction-to-ambient thermal resistance θ_{JA} must be used. Assuming a moderate air flow of 200 linear feet per minute and a multi-layer board, the appropriate value is 66.6°C/W per Table 6 below. Therefore, T_j for an ambient temperature of 70°C with all outputs switching is:

$$70^\circ C + 0.304W * 66.6^\circ C/W = 90.2^\circ C. \text{ This is well below the limit of } 125^\circ C.$$

This calculation is only an example. T_j will obviously vary depending on the number of loaded outputs, supply voltage, air flow, and the type of board (single layer or multi-layer).

TABLE 6. THERMAL RESISTANCE θ_{JA} FOR 20-PIN TSSOP, FORCED CONVECTION

θ_{JA} by Velocity (Linear Feet per Minute)			
	0	200	500
Single-Layer PCB, JEDEC Standard Test Boards	114.5°C/W	98.0°C/W	88.0°C/W
Multi-Layer PCB, JEDEC Standard Test Boards	73.2°C/W	66.6°C/W	63.5°C/W

NOTE: Most modern PCB designs use multi-layered boards. The data in the second row pertains to most designs.

3. Calculations and Equations.

The purpose of this section is to derive the power dissipated into the load.

HSTL output driver circuit and termination are shown in *Figure 6*.

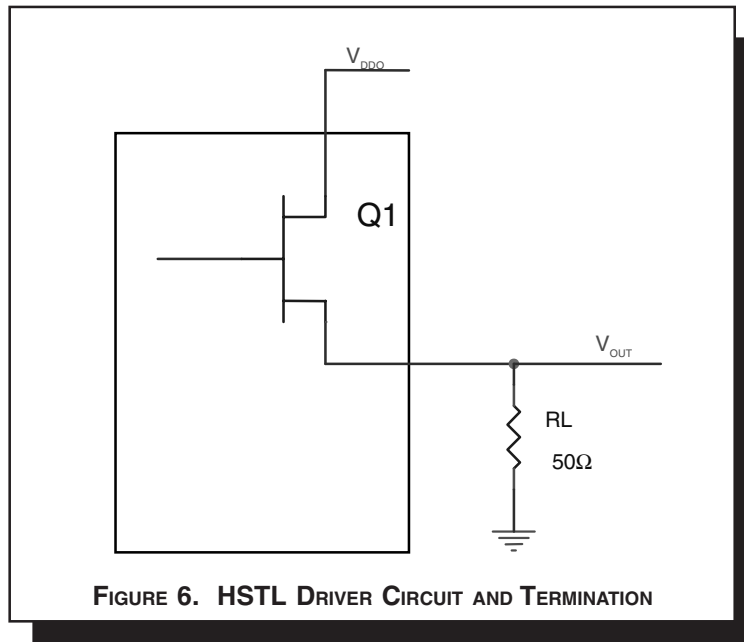

To calculate worst case power dissipation into the load, use the following equations which assume a 50Ω load.

Pd_H is power dissipation when the output drives high.
Pd_L is the power dissipation when the output drives low.

$$Pd_H = (V_{OH_MIN} / R_L) * (V_{DDO_MAX} - V_{OH_MIN})$$

$$Pd_L = (V_{OL_MAX} / R_L) * (V_{DDO_MAX} - V_{OL_MAX})$$

$$Pd_H = (0.9V/50\Omega) * (2V - 0.9V) = \mathbf{19.8mW}$$

$$Pd_L = (0.4V/50\Omega) * (2V - 0.4V) = \mathbf{12.8mW}$$

$$\text{Total Power Dissipation per output pair} = Pd_H + Pd_L = \mathbf{32.6mW}$$

RELIABILITY INFORMATION

TABLE 7. θ_{JA} VS. AIR FLOW TABLE FOR 20 LEAD TSSOP

θ_{JA} by Velocity (Linear Feet per Minute)			
	0	200	500
Single-Layer PCB, JEDEC Standard Test Boards	114.5°C/W	98.0°C/W	88.0°C/W
Multi-Layer PCB, JEDEC Standard Test Boards	73.2°C/W	66.6°C/W	63.5°C/W

NOTE: Most modern PCB designs use multi-layered boards. The data in the second row pertains to most designs.

TRANSISTOR COUNT

The transistor count for ICS8523 is: 472

PACKAGE OUTLINE - G SUFFIX FOR 20 LEAD TSSOP

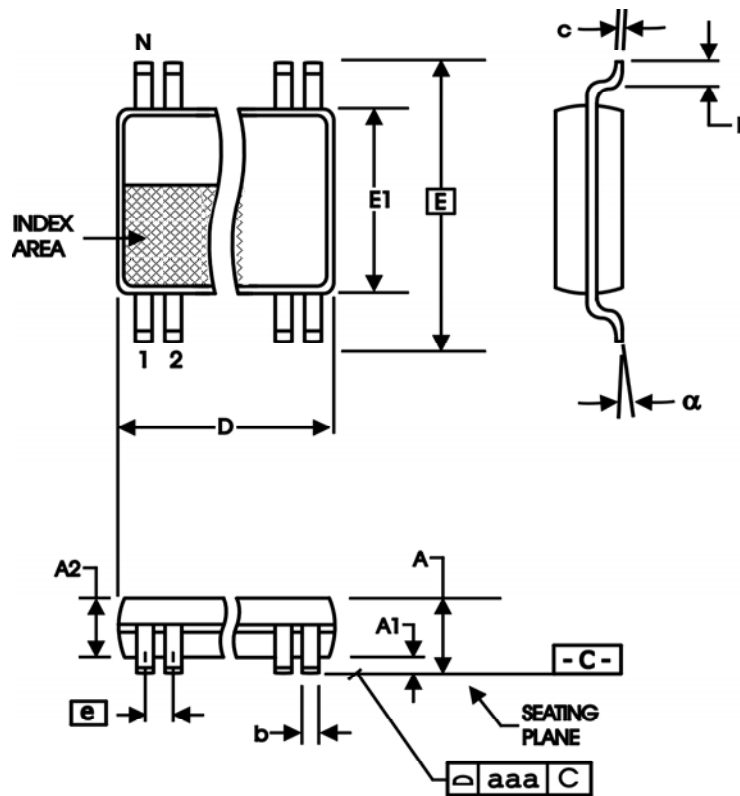

TABLE 8. PACKAGE DIMENSIONS

SYMBOL	Millimeters	
	Minimum	Maximum
N	20	
A	--	1.20
A1	0.05	0.15
A2	0.80	1.05
b	0.19	0.30
c	0.09	0.20
D	6.40	6.60
E	6.40 BASIC	
E1	4.30	4.50
e	0.65 BASIC	
L	0.45	0.75
α	0°	8°
aaa	--	0.10

Reference Document: JEDEC Publication 95, MS-153

TABLE 9. ORDERING INFORMATION

Part/Order Number	Marking	Package	Count	Temperature
ICS8523BG	ICS8523BG	20 lead TSSOP	72 per tube	0°C to 70°C
ICS8523BGT	ICS8523BG	20 lead TSSOP on Tape and Reel	2500	0°C to 70°C
ICS8523BGLF	ICS8523BGLF	20 lead "Lead-Free" TSSOP	72 per tube	0°C to 70°C
ICS8523BGLFT	ICS8523BGLF	20 lead "Lead-Free" TSSOP on Tape and Reel	2500	0°C to 70°C

The aforementioned trademark, HiPerClockS™ is a trademark of Integrated Circuit Systems, Inc. or its subsidiaries in the United States and/or other countries. While the information presented herein has been checked for both accuracy and reliability, Integrated Circuit Systems, Incorporated (ICS) assumes no responsibility for either its use or for infringement of any patents or other rights of third parties, which would result from its use. No other circuits, patents, or licenses are implied. This product is intended for use in normal commercial applications. Any other applications such as those requiring extended temperature range, high reliability, or other extraordinary environmental requirements are not recommended without additional processing by ICS. ICS reserves the right to change any circuitry or specifications without notice. ICS does not authorize or warrant any ICS product for use in life support devices or critical medical instruments.

REVISION HISTORY SHEET				
Rev	Table	Page	Description of Change	Date
B	T4D	5	L VHSTL table. Added V_{SWING} row to LVHSTL DC Characteristics Table.	7/31/01
	T5	5	AC Characteristics table. t_{PD} row, added value of 1.3 to Min.; changed Max. from 2.0 to 1.6.	
B		3	Updated Figure 1, CLK_EN Timing Diagram.	10/17/01
B		3	Updated Figure 1, CLK_EN Timing Diagram.	11/2/01
C	T5	5	AC Characteristics table. t_{PD} row, changed Min. from 1.3ns to 1.0ns. tsk(pp) row, changed Max. from 150ps to 200ps.	1/11/02
C		1	Revised Features section, Bullet 1,6 - took out 1.8V	5/6/02
C		8 - 10	In the Application Information section, added Schematic Examples.	10/25/02
D	T2	2	Pin Characteristics Table - changed C_{IN} 4pF max. to 4pF typical.	6/20/03
	T4D	4	Absolute Maximum Ratings - changed Output rating.	
		5	HSTL DC Characteristics Table - changed V_{OH} 1V min. to 0.9V min.	
		11 - 12	Power Considerations - changed Total Power Dissipation to reflect V_{OH} change. Calculations changed due to new Total Power Dissipation. Changed LVHSTL to HSTL throughout data sheet.	
D	T9	1	Features section - added Lead-Free bullet.	9/13/04
		9	Updated LVPECL Clock Input Interface section.	
		15	Added Lead-Free marking to Ordering Information table.	

Innovate with IDT and accelerate your future networks. Contact:

www.IDT.com

For Sales

800-345-7015
408-284-8200
Fax: 408-284-2775

For Tech Support

clockhelp@idt.com
408-284-8200

Corporate Headquarters

Integrated Device Technology, Inc.
6024 Silver Creek Valley Road
San Jose, CA 95138
United States
800 345 7015
+408 284 8200 (outside U.S.)

Asia Pacific and Japan

Integrated Device Technology
Singapore (1997) Pte. Ltd.
Reg. No. 199707558G
435 Orchard Road
#20-03 Wisma Atria
Singapore 238877
+65 6 887 5505

Europe

IDT Europe, Limited
Prime House
Barnett Wood Lane
Leatherhead, Surrey
United Kingdom KT22 7DE
+44 1372 363 339



www.IDT.com

Looking for pricing, stock, or lifecycle information?

Click below to explore more details on WIN SOURCE:

-  [View ICS8523BGLFT on WIN SOURCE](#)
-  [IDT, Integrated Device Technology Inc Information](#)

Optimize Your Supply Chain with WIN SOURCE Solutions

-  Global Sourcing Solution
-  Obsolete Management
-  Cost Control Management
-  Shortage Management
-  Alternative Solution
-  Excess Inventory Management