



**THE DATASHEET OF
ICS840002AGLFT**



GENERAL DESCRIPTION

The 840002 is a 2 output LVCMOS/LVTTL Synthesizer optimized to generate Fibre Channel reference clock frequencies. Using a 26.5625MHz, 18pF parallel resonant crystal, the following frequencies can be generated based on the 2 frequency select pins (F_SEL1:0): 212.5MHz, 159.375MHz, 156.25MHz, 106.25MHz, and 53.125MHz. The 840002 uses low phase noise VCO technology and can achieve 1ps or lower typical rms phase jitter, easily meeting Fibre Channel jitter requirements. The 840002 is packaged in a 16-pin TSSOP package.

FEATURES

- Two LVCMOS outputs @ 3.3V, 17Ω typical output impedance
- Selectable crystal oscillator interface or LVCMOS single-ended input
- Output frequency range: 46.66MHz - 233.33MHz
- VCO range: 560MHz - 700MHz
- Supports the following output frequencies: 212.5MHz, 159.375MHz, 156.25MHz, 106.25MHz and 53.125MHz
- RMS phase jitter @ 212.5MHz (637kHz - 10MHz): 0.83ps (typical)

Typical phase noise at 212.5MHz:

Offset	Noise Power
100Hz	-91.3 dBc/Hz
1kHz	-114.3 dBc/Hz
10kHz	-120.7 dBc/Hz
100kHz	-120.2 dBc/Hz

- Full 3.3V or 3.3V core/2.5V output supply modes
- 0°C to 70°C ambient operating temperature
- Available in lead-free RoHS compliant package

FREQUENCY SELECT FUNCTION TABLE FOR FIBRE CHANNEL APPLICATIONS

Input Frequency (MHz)	Inputs					Output Frequency (MHz)
	F_SEL1	F_SEL0	M Divider Value	N Divider Value	M/N Ratio Value	
26.5625	0	0	24	3	8	212.5
26.5625	0	1	24	4	6	159.375
26.5625	1	0	24	6	4	106.25
26.5625	1	1	24	12	2	53.125
26.04166	0	1	24	4	6	156.25

BLOCK DIAGRAM

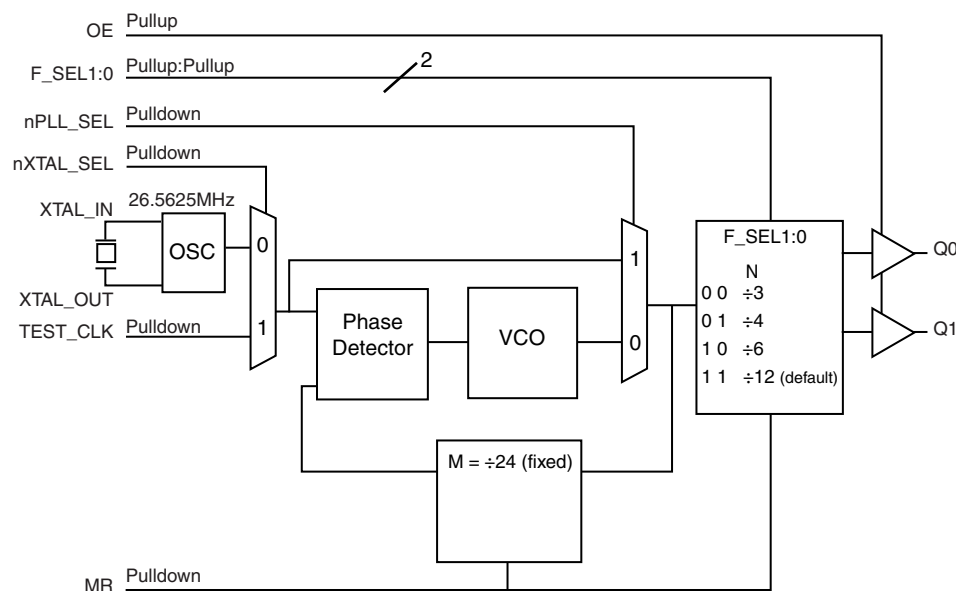

PIN ASSIGNMENT

F_SEL0	1	16	F_SEL1
nXTAL_SEL	2	15	GND
TEST_CLK	3	14	GND
OE	4	13	Q0
MR	5	12	Q1
nPLL_SEL	6	11	VDD0
VDDA	7	10	XTAL_IN
VDD	8	9	XTAL_OUT

840002
16-Lead TSSOP
 4.4mm x 5.0mm x 0.92mm
 package body
G Package
 Top View

TABLE 1. PIN DESCRIPTIONS

Number	Name	Type		Description
1	F_SELO	Input	Pullup	Frequency select pin. LVCMOS/LVTTL interface levels.
2	nXTAL_SEL	Input	Pulldown	Selects between the crystal or TEST_CLK inputs as the PLL reference source. When HIGH, selects TEST_CLK. When LOW, selects XTAL inputs. LVCMOS/LVTTL interface levels.
3	TEST_CLK	Input	Pulldown	Single-ended LVCMOS/LVTTL clock input.
4	OE	Input	Pullup	Output enable pin. When HIGH, the outputs are active. When LOW, the outputs are in a high impedance state. LVCMOS/LVTTL interface levels.
5	MR	Input	Pulldown	Active HIGH Master Reset. When logic HIGH, the internal dividers are reset causing active outputs to go low. When logic LOW, the internal dividers and the outputs are enabled. LVCMOS/LVTTL interface levels.
6	nPLL_SEL	Input	Pulldown	PLL Bypass. When LOW, the output is driven from the VCO output. When HIGH, the PLL is bypassed and the output frequency = reference clock frequency/n output divider. LVCMOS/LVTTL interface levels.
7	V _{DDA}	Power		Analog supply pin.
8	V _{DD}	Power		Core supply pin.
9, 10	XTAL_OUT, XTAL_IN	Input		Crystal oscillator interface.
11	V _{DDO}	Power		Output supply pin.
12, 13	Q1, Q0	Output		Single-ended clock outputs. LVCMOS/LVTTL interface levels.
14, 15	GND	Power		Power supply ground.
16	F_SEL1	Input	Pullup	Frequency select pin. LVCMOS/LVTTL interface levels.

NOTE: *Pullup* and *Pulldown* refer to internal input resistors. See Table 2, Pin Characteristics, for typical values.

TABLE 2. PIN CHARACTERISTICS

Symbol	Parameter	Test Conditions	Minimum	Typical	Maximum	Units
C _{IN}	Input Capacitance			4		pF
C _{PD}	Power Dissipation Capacitance			8		pF
R _{PULLUP}	Input Pullup Resistor			51		kΩ
R _{PULLDOWN}	Input Pulldown Resistor			51		kΩ
R _{OUT}	Output Impedance	3.3V±5%	14	17	21	Ω
		2.5V±5%	16	21	25	Ω

TABLE 3. FREQUENCY SELECT FUNCTION TABLE

Input Frequency (MHz)	Inputs					Output Frequency (MHz)
	F_SEL1	F_SELO	M Divider Value	N Divider Value	M/N Divider Value	
26.5625	0	0	24	3	8	212.5
26.5625	0	1	24	4	6	159.375
26.5625	1	0	24	6	4	106.25
26.5625	1	1	24	12	2	53.125
26.04166	0	1	24	4	6	156.25

ABSOLUTE MAXIMUM RATINGS

Supply Voltage, V_{DD}	4.6V
Inputs, V_i	-0.5V to $V_{DD} + 0.5V$
Outputs, V_o	-0.5V to $V_{DD} + 0.5V$
Package Thermal Impedance, θ_{JA}	89°C/W (0 lfpm)
Storage Temperature, T_{STG}	-65°C to 150°C

NOTE: Stresses beyond those listed under Absolute Maximum Ratings may cause permanent damage to the device. These ratings are stress specifications only. Functional operation of product at these conditions or any conditions beyond those listed in the *DC Characteristics* or *AC Characteristics* is not implied. Exposure to absolute maximum rating conditions for extended periods may affect product reliability.

TABLE 4A. POWER SUPPLY DC CHARACTERISTICS, $V_{DD} = V_{DDA} = 3.3V \pm 5\%$, $V_{DDO} = 3.3V \pm 5\%$ OR $2.5V \pm 5\%$, $T_A = 0^\circ C$ TO $70^\circ C$

Symbol	Parameter	Test Conditions	Minimum	Typical	Maximum	Units
V_{DD}	Core Supply Voltage		3.135	3.3	3.465	V
V_{DDA}	Analog Supply Voltage		3.135	3.3	3.465	V
V_{DDO}	Output Supply Voltage		3.135	3.3	3.465	V
			2.375	2.5	2.625	V
I_{DD}	Power Supply Current				100	mA
I_{DDA}	Analog Supply Current				12	mA
I_{DDO}	Output Supply Current				5	mA

TABLE 4B. LVCMOS/LVTTL DC CHARACTERISTICS, $V_{DD} = V_{DDA} = 3.3V \pm 5\%$, $V_{DDO} = 3.3V \pm 5\%$ OR $2.5V \pm 5\%$, $T_A = 0^\circ C$ TO $70^\circ C$

Symbol	Parameter	Test Conditions	Minimum	Typical	Maximum	Units
V_{IH}	Input High Voltage	F_SEL1:0, nPLL_SEL, nXTAL_SEL, OE, MR	2		$V_{DD} + 0.3$	V
		TEST_CLK	2		$V_{DD} + 0.3$	V
V_{IL}	Input Low Voltage	F_SEL1:0, nPLL_SEL, nXTAL_SEL, OE, MR	-0.3		0.8	V
		TEST_CLK	-0.3		1.3	V
I_{IH}	Input High Current	OE, F_SEL0, F_SEL1	$V_{DD} = V_{IN} = 3.465V$		5	μA
		nPLL_SEL, MR, nXTAL_SEL, TEST_CLK	$V_{DD} = V_{IN} = 3.465V$		150	μA
I_{IL}	Input Low Current	OE, F_SEL0, F_SEL1	$V_{DD} = 3.465V, V_{IN} = 0V$		-150	μA
		nPLL_SEL, MR, nXTAL_SEL, TEST_CLK	$V_{DD} = 3.465V, V_{IN} = 0V$		-5	μA
V_{OH}	Output High Voltage; NOTE 1	$V_{DDO} = 3.3V \pm 5\%$	2.6			V
		$V_{DDO} = 2.5V \pm 5\%$	1.8			V
V_{OL}	Output Low Voltage; NOTE 1	$V_{DDO} = 3.3V$ or $2.5V \pm 5\%$			0.5	V

NOTE 1: Outputs terminated with 50W to $V_{DDO}/2$. See Parameter Measurement Information, Output Load Test Circuit.

TABLE 5. CRYSTAL CHARACTERISTICS

Parameter	Test Conditions	Minimum	Typical	Maximum	Units
Mode of Oscillation		Fundamental			
Frequency			26.5625		MHz
Equivalent Series Resistance (ESR)				50	Ω
Shunt Capacitance				7	pF
Drive Level				1	mW

NOTE: Characterized using an 18pf parallel resonant crystal.

TABLE 6A. AC CHARACTERISTICS, $V_{DD} = V_{DDA} = V_{DDO} = 3.3V \pm 5\%$, $T_A = 0^\circ\text{C}$ TO 70°C

Symbol	Parameter	Test Conditions	Minimum	Typical	Maximum	Units
f_{OUT}	Output Frequency Range	F_SEL[1:0] = 00	186.67		226.67	MHz
		F_SEL[1:0] = 01	140		170	MHz
		F_SEL[1:0] = 10	93.33		113.33	MHz
		F_SEL[1:0] = 11	46.67		56.67	MHz
$t_{sk(o)}$	Output Skew; NOTE 1, 3			12	ps	
$t_{jit}(\emptyset)$	RMS Phase Jitter (Random); NOTE 2	212.5MHz @ Integration Range: 637kHz - 10MHz		0.83		ps
		159.375MHz @ Integration Range: 637kHz - 10MHz		0.62		ps
		156.25MHz @ Integration Range: 1.875MHz - 20MHz		0.59		ps
		106.25MHz @ Integration Range: 637kHz - 10MHz		0.80		ps
		53.125MHz @ Integration Range: 637kHz - 10MHz		0.68		ps
t_R / t_F	Output Rise/Fall Time	20% to 80%	200		700	ps
odc	Output Duty Cycle	F_SEL[1:0] = 00	46		54	%
		F_SEL[1:0] = 00	42		58	%

NOTE 1: Defined as skew between outputs at the same supply voltages and with equal load conditions.
Measured at $V_{DDO}/2$.

NOTE 2: Please refer to the Phase Noise Plot.

NOTE 3: This parameter is defined in accordance with JEDEC Standard 65.

TABLE 6B. AC CHARACTERISTICS, $V_{DD} = V_{DDA} = 3.3V \pm 5\%$, $V_{DDO} = 2.5V \pm 5\%$, $T_A = 0^\circ\text{C}$ TO 70°C

Symbol	Parameter	Test Conditions	Minimum	Typical	Maximum	Units
f_{OUT}	Output Frequency Range	F_SEL[1:0] = 00	186.67		226.67	MHz
		F_SEL[1:0] = 01	140		170	MHz
		F_SEL[1:0] = 10	93.33		113.33	MHz
		F_SEL[1:0] = 11	46.67		56.67	MHz
$t_{sk(o)}$	Output Skew; NOTE 1, 3			12	ps	
$t_{jit}(\emptyset)$	RMS Phase Jitter (Random); NOTE 2	212.5MHz @ Integration Range: 637kHz - 10MHz		0.73		ps
		159.375MHz @ Integration Range: 637kHz - 10MHz		0.62		ps
		156.25MHz @ Integration Range: 1.875MHz - 20MHz		0.56		ps
		106.25MHz @ Integration Range: 637kHz - 10MHz		0.76		ps
		53.125MHz @ Integration Range: 637kHz - 10MHz		0.72		ps
t_R / t_F	Output Rise/Fall Time	20% to 80%	200		700	ps
odc	Output Duty Cycle	F_SEL[1:0] = 00	46		54	%
		F_SEL[1:0] = 00	42		58	%

NOTE 1: Defined as skew between outputs at the same supply voltages and with equal load conditions.
Measured at $V_{DDO}/2$.

NOTE 2: Please refer to the Phase Noise Plot.

NOTE 3: This parameter is defined in accordance with JEDEC Standard 65.

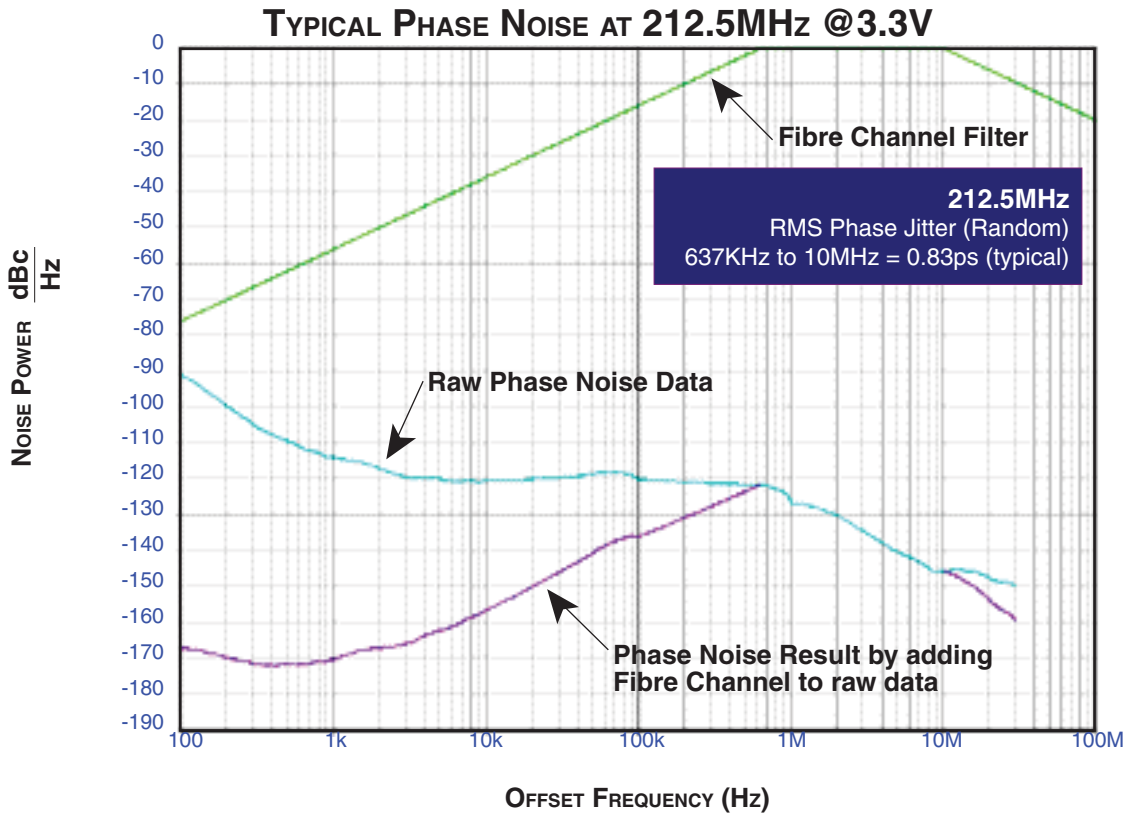
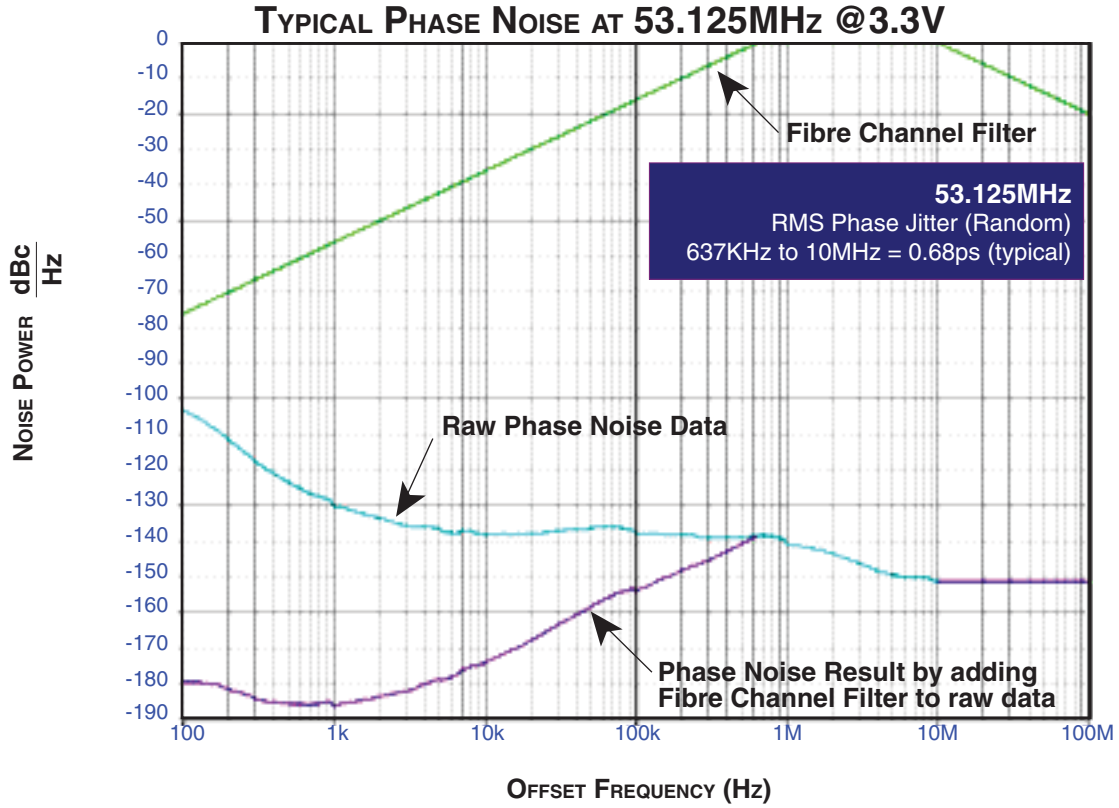

PARAMETER MEASUREMENT INFORMATION

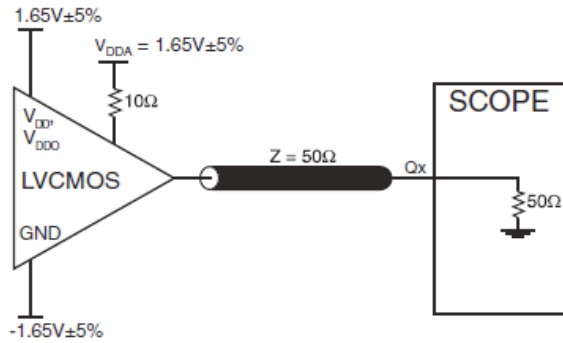

3.3V CORE/3.3V OUTPUT LOAD AC TEST CIRCUIT

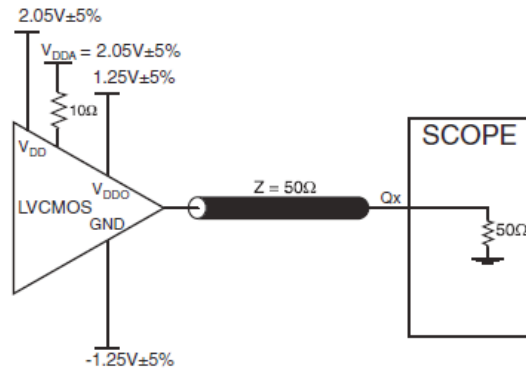

3.3V CORE/2.5V OUTPUT LOAD AC TEST CIRCUIT

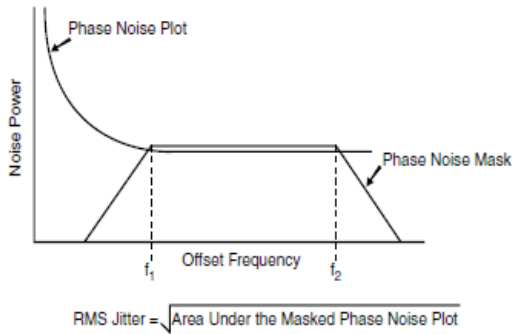

RMS PHASE JITTER

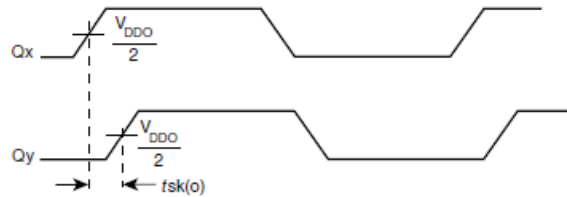

OUTPUT SKEW

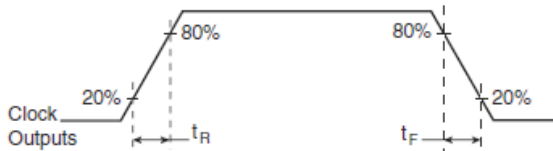

OUTPUT RISE/FALL TIME

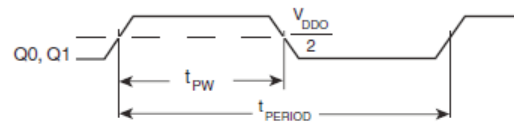

$$\text{odc} = \frac{t_{PW}}{t_{PERIOD}} \times 100\%$$

OUTPUT DUTY CYCLE/PULSE WIDTH/PERIOD

APPLICATION INFORMATION

POWER SUPPLY FILTERING TECHNIQUES

As in any high speed analog circuitry, the power supply pins are vulnerable to random noise. The 840002 provides separate power supplies to isolate any high switching noise from the outputs to the internal PLL. V_{DD} , V_{DDA} , and V_{DDO} should be individually connected to the power supply plane through vias, and bypass capacitors should be used for each pin. To achieve optimum jitter performance, power supply isolation is required. *Figure 1* illustrates how a 10Ω resistor along with a $10\mu\text{F}$ and a $.01\mu\text{F}$ bypass capacitor should be connected to each V_{DDA} .

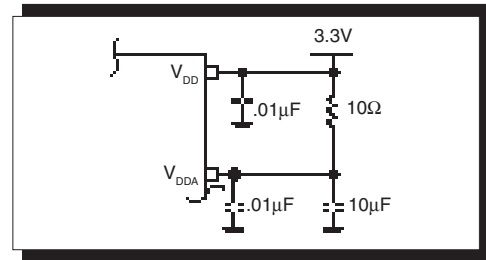

FIGURE 1. POWER SUPPLY FILTERING

CRYSTAL INPUT INTERFACE

The 840002 has been characterized with 18pF parallel resonant crystals. The capacitor values shown in *Figure 2* below were

determined using a 26.5625MHz, 18pF parallel resonant crystal and were chosen to minimize the ppm error.

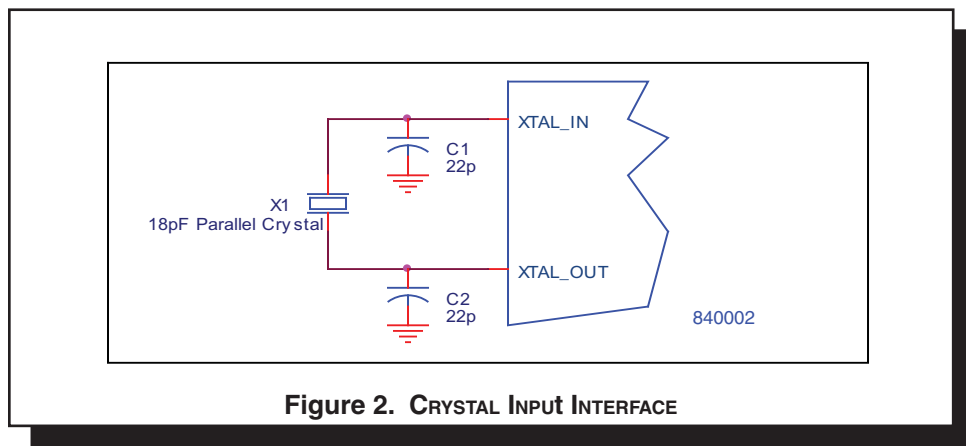

Figure 2. CRYSTAL INPUT INTERFACE

RECOMMENDATIONS FOR UNUSED INPUT AND OUTPUT PINS

INPUTS:

CRYSTAL INPUT:

For applications not requiring the use of the crystal oscillator input, both XTAL_IN and XTAL_OUT can be left floating. Though not required, but for additional protection, a 1kΩ resistor can be tied from XTAL_IN to ground.

TEST_CLK INPUT:

For applications not requiring the use of the test clock, it can be left floating. Though not required, but for additional protection, a 1kΩ resistor can be tied from the TEST_CLK to ground.

LVC MOS CONTROL PINS:

All control pins have internal pull-ups or pull-downs; additional resistance is not required but can be added for additional protection. A 1kΩ resistor can be used.

OUTPUTS:

LVC MOS OUTPUT:

All unused LVC MOS output can be left floating. We recommend that there is no trace attached.

LAYOUT GUIDELINE

Figure 3 shows a schematic example of the 840002. An example of LVC MOS termination is shown in this schematic. Additional LVC MOS termination approaches are shown in the LVC MOS Termination Application Note. In this example, an 18 pF parallel resonant 26.5625MHz crystal is used. The C1=22pF and

C2=22pF are recommended for frequency accuracy. For different board layout, the C1 and C2 may be slightly adjusted for optimizing frequency accuracy. 1KΩ pullup or pulldown resistors can be used for the logic control input pins.

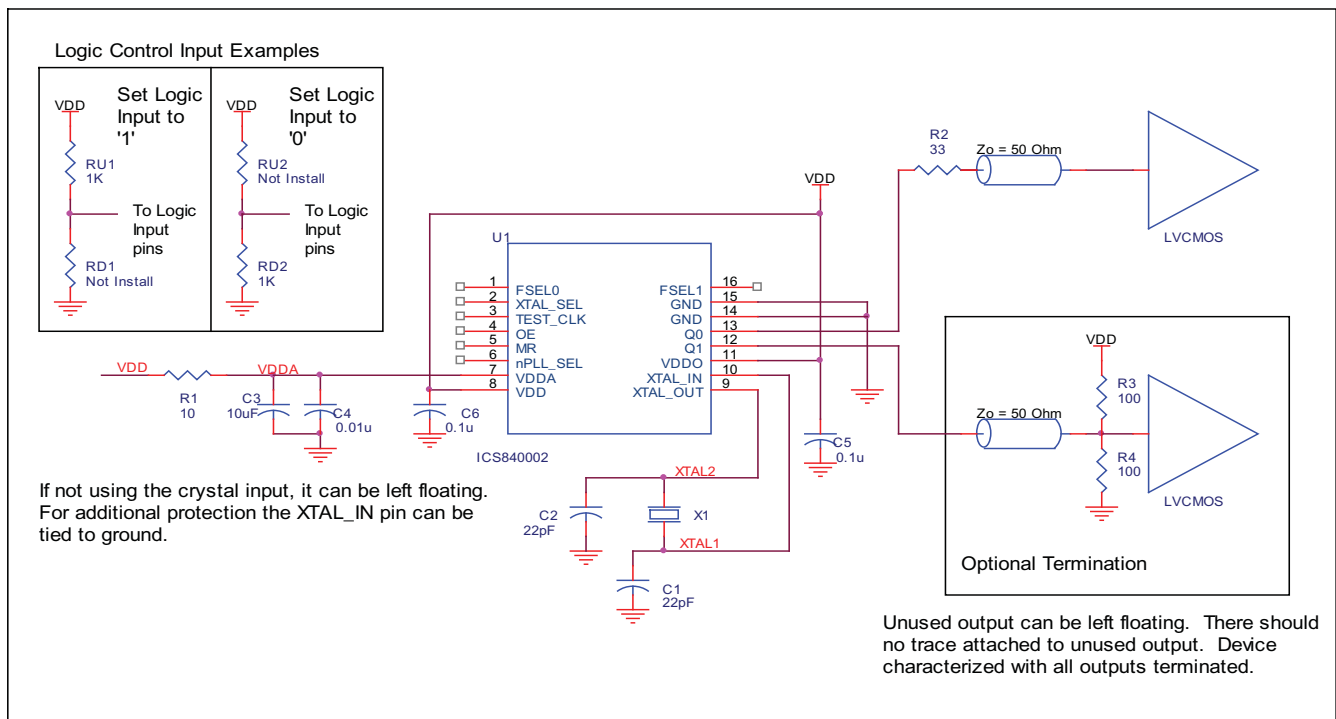

FIGURE 3. 840002 SCHEMATIC EXAMPLE

RELIABILITY INFORMATION

TABLE 7. θ_{JA} VS. AIR FLOW TABLE FOR 16 LEAD TSSOP

θ_{JA} by Velocity (Linear Feet per Minute)			
	0	200	500
Single-Layer PCB, JEDEC Standard Test Boards	137.1°C/W	118.2°C/W	106.8°C/W
Multi-Layer PCB, JEDEC Standard Test Boards	89.0°C/W	81.8°C/W	78.1°C/W

NOTE: Most modern PCB designs use multi-layered boards. The data in the second row pertains to most designs.

TRANSISTOR COUNT

The transistor count for 840002 is: 3085

PACKAGE OUTLINE - G SUFFIX FOR 16 LEAD TSSOP

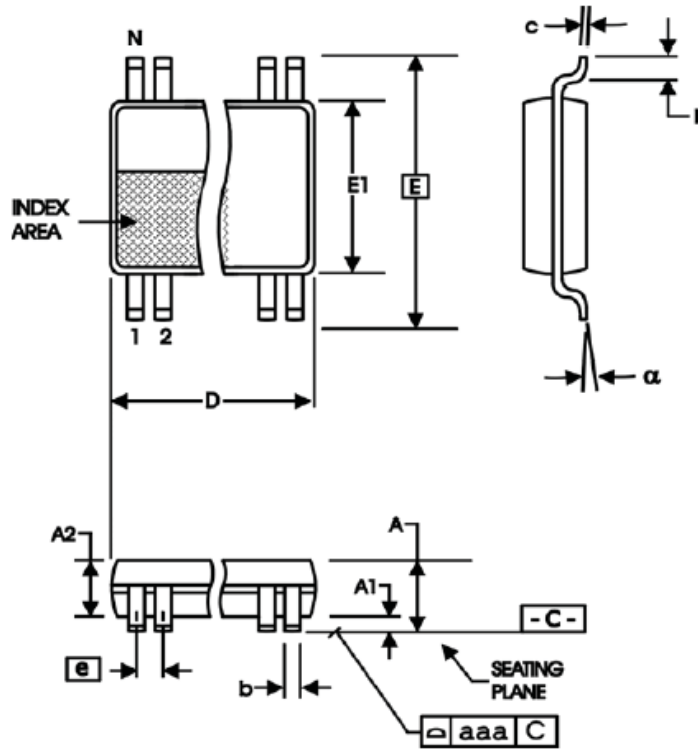

TABLE 8. PACKAGE DIMENSIONS

SYMBOL	Millimeters	
	Minimum	Maximum
N	16	
A	--	1.20
A1	0.05	0.15
A2	0.80	1.05
b	0.19	0.30
c	0.09	0.20
D	4.90	5.10
E	6.40 BASIC	
E1	4.30	4.50
e	0.65 BASIC	
L	0.45	0.75
α	0°	8°
aaa	--	0.10

Reference Document: JEDEC Publication 95, MO-153

TABLE 9. ORDERING INFORMATION

Part/Order Number	Marking	Package	Shipping Packaging	Temperature
ICS840002AGLF	840002AL	16 Lead "Lead-Free" TSSOP	tube	0°C to 70°C
ICS840002AGLFT	840002AL	16 Lead "Lead-Free" TSSOP	tape & reel	0°C to 70°C

NOTE: Parts that are ordered with an "LF" suffix to the part number are the Pb-Free configuration and are RoHS compliant.

REVISION HISTORY SHEET				
Rev	Table	Page	Description of Change	Date
B	T5	3	Crystal Characteristics Table - added Drive Level.	2/17/06
	T9	6	Updated Output Load AC Test Circuit diagrams.	
		8	Added Recommendations for Unused Input and Output Pins.	
		11	Ordering Information Table - corrected standard marking and added lead-free marking and note.	
C	T9	11	Ordering information - removed leaded devices - PDN CQ-13-02 expired. Updated Datasheet format.	11/10/14



Corporate Headquarters

6024 Silver Creek Valley Road
San Jose, California 95138

Sales

800-345-7015 or +408-284-8200
Fax: 408-284-2775
www.IDT.com

Technical Support

email: clocks@idt.com

DISCLAIMER Integrated Device Technology, Inc. (IDT) and its subsidiaries reserve the right to modify the products and/or specifications described herein at any time and at IDT's sole discretion. All information in this document, including descriptions of product features and performance, is subject to change without notice. Performance specifications and the operating parameters of the described products are determined in the independent state and are not guaranteed to perform the same way when installed in customer products. The information contained herein is provided without representation or warranty of any kind, whether express or implied, including, but not limited to, the suitability of IDT's products for any particular purpose, an implied warranty of merchantability, or non-infringement of the intellectual property rights of others. This document is presented only as a guide and does not convey any license under intellectual property rights of IDT or any third parties.

IDT's products are not intended for use in applications involving extreme environmental conditions or in life support systems or similar devices where the failure or malfunction of an IDT product can be reasonably expected to significantly affect the health or safety of users. Anyone using an IDT product in such a manner does so at their own risk, absent an express, written agreement by IDT.

Integrated Device Technology, IDT and the IDT logo are registered trademarks of IDT. Other trademarks and service marks used herein, including protected names, logos and designs, are the property of IDT or their respective third party owners.

Copyright 2014. All rights reserved.

Looking for pricing, stock, or lifecycle information?

Click below to explore more details on WIN SOURCE:

- ⊖ [View ICS840002AGLFT on WIN SOURCE](#)
- ⊖ [IDT, Integrated Device Technology Inc Information](#)

Optimize Your Supply Chain with WIN SOURCE Solutions

- ✓ Global Sourcing Solution
- ✓ Obsolete Management
- ✓ Cost Control Management
- ✓ Shortage Management
- ✓ Alternative Solution
- ✓ Excess Inventory Management