



**THE DATASHEET OF
ICS8305AGLFT**



General Description

The ICS8305 is a low skew, 1-to-4, Differential/ LVCMOS-to-LVCMOS/LVTTL Fanout Buffer. The ICS8305 has selectable clock inputs that accept either differential or single ended input levels. The clock enable is internally synchronized to eliminate runt pulses on the outputs during asynchronous assertion/deassertion of the clock enable pin. Outputs are forced LOW when the clock is disabled. A separate output enable pin controls whether the outputs are in the active or high impedance state.

Guaranteed output and part-to-part skew characteristics make the ICS8305 ideal for those applications demanding well defined performance and repeatability.

Features

- Four LVCMOS / LVTTL outputs, 7Ω output impedance
- Selectable differential or LVCMOS / LVTTL clock inputs
- CLK, nCLK pair can accept the following differential input levels: LVPECL, LVDS, LVHSTL, HCSL, SSTL
- LVCMOS_CLK supports the following input types: LVCMOS, LVTTL
- Maximum output frequency: 350MHz
- Output skew: 35ps (maximum)
- Part-to-part skew: 700ps (maximum)
- Additive phase jitter, RMS: 0.04ps (typical)
- Power supply modes:
Core/Output
3.3V/3.3V
3.3V/2.5V
3.3V/1.8V
3.3V/1.5V
- 0°C to 70°C ambient operating temperature
- Available in lead-free (RoHS 6) package

Block Diagram

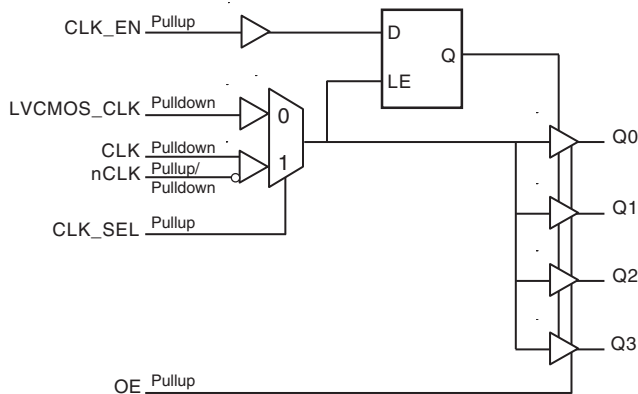

Pin Assignment

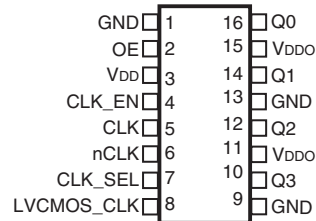

ICS8305
16-Lead TSSOP
4.4mm x 3.0mm x 0.925mm package body
G Package
Top View

Table 1. Pin Descriptions

Number	Name	Type		Description
1, 9, 13	GND	Power		Power supply ground
2	OE	Input	Pullup	Output enable. When LOW, outputs are in HIGH impedance state. When HIGH, outputs are active. LVCMOS/LVTTL interface levels.
3	V _{DD}	Power		Power supply pin.
4	CLK_EN	Input	Pullup	Synchronizing clock enable. When LOW, the output clocks are disabled. When HIGH, output clocks are enabled. LVCMOS/LVTTL interface levels.
5	CLK	Input	Pulldown	Non-inverting differential clock input.
6	nCLK	Input	Pullup/ Pulldown	Inverting differential clock input. VDD/2 default when left floating.
7	CLK_SEL	Input	Pullup	Clock select input. When HIGH, selects CLK, nCLK inputs. When LOW, selects LVCMOS_CLK input. LVCMOS/LVTTL interface levels.
8	LVCMOS_CLK	Input	Pulldown	Single-ended clock input. LVCMOS/LVTTL interface levels.
10, 12, 14, 16	Q3, Q2, Q1, Q0	Output		Single-ended clock outputs. 7 Ω output impedance. LVCMOS/LVTTL interface levels.
11, 15	V _{DDO}	Power		Output supply pins.

NOTE: *Pullup* and *Pulldown* refer to internal input resistors. See Table 2, *Pin Characteristics*, for typical values.

Table 2. Pin Characteristics

Symbol	Parameter	Test Conditions	Minimum	Typical	Maximum	Units
C _{IN}	Input Capacitance			4		pF
R _{PULLUP}	Input Pullup Resistor			51		k Ω
R _{PULLDOWN}	Input Pulldown Resistor			51		k Ω
C _{PD}	Power Dissipation Capacitance (per output)			11		pF
R _{OUT}	Output Impedance			7		Ω

Function Tables

Table 3. Control Input Function Table

Inputs				Outputs
OE	CLK_EN	CLK_SEL	Selected Source	Q0:Q3
1	0	0	LVCMOS_CLK	Disabled; Low
1	0	1	CLK/nCLK	Disabled; Low
1	1	0	LVCMOS_CLK	Enabled
1	1	1	CLK/nCLK	Enabled
0	X	X		Hi-Z

After CLK_EN switches, the clock outputs are disabled or enabled following a rising and falling input clock edge as shown in Figure 1.

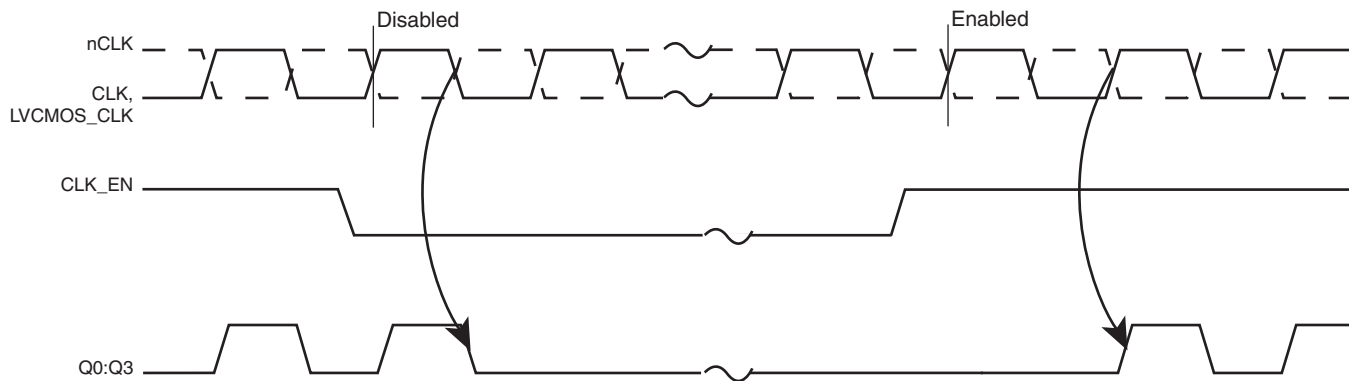

Figure 1. CLK_EN Timing Diagram

Absolute Maximum Ratings

NOTE: Stresses beyond those listed under *Absolute Maximum Ratings* may cause permanent damage to the device. These ratings are stress specifications only. Functional operation of product at these conditions or any conditions beyond those listed in the *DC Characteristics* or *AC Characteristics* is not implied. Exposure to absolute maximum rating conditions for extended periods may affect product reliability.

Item	Rating
Supply Voltage, V_{DD}	4.6V
Inputs, V_I	-0.5V to $V_{DD} + 0.5V$
Outputs, V_O	-0.5V to $V_{DDO} + 0.5V$
Package Thermal Impedance, θ_{JA}	89°C/W (0 lfpm)
Storage Temperature, T_{STG}	-65°C to 150°C

DC Electrical Characteristics

Table 4A. Power Supply DC Characteristics, $V_{DD} = 3.3V \pm 5\%$, $V_{DDO} = 3.3V \pm 5\%$ or $2.5V \pm 5\%$ or $1.8V \pm 0.5V$ or $1.5V \pm 5\%$, $T_A = 0^\circ\text{C}$ to 70°C

Symbol	Parameter	Test Conditions	Minimum	Typical	Maximum	Units
V_{DD}	Positive Supply Voltage		3.135	3.3	3.465	V
V_{DDO}	Output Supply Voltage		3.135	3.3	3.465	V
			2.375	2.5	2.625	V
			1.65	1.8	1.95	V
			1.425	1.5	1.575	V
I_{DD}	Power Supply Current				21	mA
I_{DDO}	Output Supply Current				5	mA

Table 4B. LVCMOS/LVTTL DC Characteristics, $T_A = 0^\circ\text{C}$ to 70°C

Symbol	Parameter	Test Conditions	Minimum	Typical	Maximum	Units
V_{IH}	Input High Voltage	CLK_EN, CLK_SEL, OE	2		$V_{DD} + 0.3$	V
		LVCMOS_CLK	2		$V_{DD} + 0.3$	V
V_{IL}	Input Low Voltage	CLK_EN, CLK_SEL, OE	-0.3		0.8	V
		LVCMOS_CLK	-0.3		1.3	V
I_{IH}	Input High Current	CLK_EN, CLK_SEL, OE	$V_{DD} = V_{IN} = 3.465\text{V}$		5	μA
		LVCMOS_CLK	$V_{DD} = V_{IN} = 3.465\text{V}$		150	μA
I_{IL}	Input Low Current	CLK_EN, CLK_SEL, OE	$V_{DD} = 3.465\text{V}, V_{IN} = 0\text{V}$	-150		μA
		LVCMOS_CLK	$V_{DD} = 3.465\text{V}, V_{IN} = 0\text{V}$	-5		μA
V_{OH}	Output High Voltage; NOTE 1		$V_{DDO} = 3.3\text{V} \pm 5\%$	2.6		V
			$V_{DDO} = 2.5\text{V} \pm 5\%$	1.8		V
			$V_{DDO} = 1.8\text{V} \pm 0.15\text{V}$	1.5		V
			$V_{DDO} = 1.5\text{V} \pm 5\%$	$V_{DDO} - 0.3$		V
V_{OL}	Output Low Voltage; NOTE 1		$V_{DDO} = 3.3\text{V} \pm 5\%$		0.5	V
			$V_{DDO} = 2.5\text{V} \pm 5\%$		0.5	V
			$V_{DDO} = 1.8\text{V} \pm 0.15\text{V}$		0.4	V
			$V_{DDO} = 1.5\text{V} \pm 5\%$		0.35	V
I_{OZL}	Output Hi-Z Current Low		-5			μA
I_{OZH}	Output Hi-Z Current High				5	μA

NOTE 1: Outputs terminated with 50Ω to $V_{DDO}/2$. See Parameter Measurement Information, *Output Load Test Circuit diagrams*.

Table 4C. Differential DC Characteristics, $T_A = -40^\circ\text{C}$ to 85°C

Symbol	Parameter	Test Conditions	Minimum	Typical	Maximum	Units
I_{IH}	Input High Current	nCLK	$V_{DD} = V_{IN} = 3.465\text{V}$		150	μA
		CLK	$V_{DD} = V_{IN} = 3.465\text{V}$		150	μA
I_{IL}	Input Low Current	nCLK	$V_{DD} = 3.465\text{V}, V_{IN} = 0\text{V}$	-150		μA
		CLK	$V_{DD} = 3.465\text{V}, V_{IN} = 0\text{V}$	-5		μA
V_{PP}	Peak-to-Peak Voltage; NOTE 1		0.15		1.3	V
V_{CMR}	Common Mode Input Voltage; NOTE 1, 2		GND + 0.5		$V_{DD} - 0.85$	V

NOTE 1: V_{IL} should not be less than -0.3V.

NOTE 2: Common mode input voltage is defined as V_{IH} .

AC Electrical Characteristics

Table 5A. AC Characteristics, $V_{DD} = V_{DDO} = 3.3V \pm 5\%$, $T_A = 0^\circ C$ to $70^\circ C$

Parameter	Symbol	Test Conditions	Minimum	Typical	Maximum	Units
f_{MAX}	Output Frequency				350	MHz
t_{PLH}	Propagation Delay, Low to High	LVC MOS_CLK; NOTE 1A CLK/nCLK; NOTE 1B	1.75		2.75	ns
$t_{sk(o)}$	Output Skew; NOTE 2, 6	Measured on the Rising Edge			35	ps
$t_{sk(pp)}$	Part-to-Part Skew; NOTE 3, 6				700	ps
t_{jit}	Buffer Additive Phase Jitter, RMS; refer to Additive Phase Jitter Section, NOTE 5			0.04		ps
t_R / t_F	Output Rise/Fall Time; NOTE 4	20% to 80%	100		700	ps
odc	Output Duty Cycle	Ref = CLK/nCLK	45		55	%
		Ref = LVC MOS_CLK, $f \leq 300MHz$	45		55	%
t_{EN}	Output Enable Time; NOTE 4				5	ns
t_{DIS}	Output Disable Time; NOTE 4				5	ns

NOTE: Electrical parameters are guaranteed over the specified ambient operating temperature range, which is established when the device is mounted in a test socket with maintained transverse airflow greater than 500 lpm. The device will meet specifications after thermal equilibrium has been reached under these conditions.

All parameters measured at $f \leq 350MHz$ unless noted otherwise.

NOTE 1A: Measured from the $V_{DD}/2$ of the input to $V_{DDO}/2$ of the output.

NOTE 1B: Measured from the differential input crossing point to $V_{DDO}/2$ of the output.

NOTE 2: Defined as skew between outputs at the same supply voltage and with equal load conditions. Measured at $V_{DDO}/2$.

NOTE 3: Defined as skew between outputs on different devices operating at the same supply voltages and with equal load conditions. Using the same type of input on each device, the output is measured at $V_{DDO}/2$.

NOTE 4: These parameters are guaranteed by characterization. Not tested in production.

NOTE 5: Driving only one input clock.

NOTE 6: This parameter is defined in accordance with JEDEC Standard 65.

Table 5B. AC Characteristics, $V_{DD} = 3.3V \pm 5\%$, $V_{DDO} = 2.5V \pm 5\%$, $T_A = 0^\circ C$ to $70^\circ C$

Parameter	Symbol	Test Conditions	Minimum	Typical	Maximum	Units
f_{MAX}	Output Frequency				350	MHz
t_{PLH}	Propagation Delay, Low to High	LVC MOS_CLK; NOTE 1A CLK/nCLK; NOTE 1B	1.8		2.9	ns
$t_{sk(o)}$	Output Skew; NOTE 2, 6	Measured on the Rising Edge			35	ps
$t_{sk(pp)}$	Part-to-Part Skew; NOTE 3, 6				800	ps
t_{jit}	Buffer Additive Phase Jitter, RMS; refer to Additive Phase Jitter Section, NOTE 5			0.04		ps
t_R / t_F	Output Rise/Fall Time; NOTE 4	20% to 80%	100		700	ps
odc	Output Duty Cycle	Ref = CLK/nCLK	44		56	%
		Ref = LVC MOS_CLK, $f \leq 300MHz$	44		56	%
t_{EN}	Output Enable Time; NOTE 4				5	ns
t_{DIS}	Output Disable Time; NOTE 4				5	ns

For NOTES, see Table 5A above.

Table 5C. AC Characteristics, $V_{DD} = 3.3V \pm 5\%$, $V_{DDO} = 1.8V \pm 0.15V$, $T_A = 0^\circ C$ to $70^\circ C$

Parameter	Symbol	Test Conditions	Minimum	Typical	Maximum	Units
f_{MAX}	Output Frequency				350	MHz
t_{pLH}	Propagation Delay, Low to High	LVCMOS_CLK; NOTE 1A CLK/nCLK; NOTE 1B	1.95		3.65	ns
$t_{sk(o)}$	Output Skew; NOTE 2, 6	Measured on the Rising Edge			35	ps
$t_{sk(pp)}$	Part-to-Part Skew; NOTE 3, 6				900	ps
t_{jit}	Buffer Additive Phase Jitter, RMS; refer to Additive Phase Jitter Section, NOTE 5			0.04		ps
t_R / t_F	Output Rise/Fall Time; NOTE 4	20% to 80%	100		700	ps
odc	Output Duty Cycle	Ref = CLK/nCLK	44		56	%
		Ref = LVCMOS_CLK, $f \leq 300MHz$	44		56	%
t_{EN}	Output Enable Time; NOTE 4				5	ns
t_{DIS}	Output Disable Time; NOTE 4				5	ns

NOTE: Electrical parameters are guaranteed over the specified ambient operating temperature range, which is established when the device is mounted in a test socket with maintained transverse airflow greater than 500 lpm. The device will meet specifications after thermal equilibrium has been reached under these conditions.

All parameters measured at $f \leq 350MHz$ unless noted otherwise.

NOTE 1A: Measured from the $V_{DD}/2$ of the input to $V_{DDO}/2$ of the output.

NOTE 1B: Measured from the differential input crossing point to $V_{DDO}/2$ of the output.

NOTE 2: Defined as skew between outputs at the same supply voltage and with equal load conditions. Measured at $V_{DDO}/2$.

NOTE 3: Defined as skew between outputs on different devices operating at the same supply voltages and with equal load conditions. Using the same type of input on each device, the output is measured at $V_{DDO}/2$.

NOTE 4: These parameters are guaranteed by characterization. Not tested in production.

NOTE 5: Driving only one input clock.

NOTE 6: This parameter is defined in accordance with JEDEC Standard 65.

Table 5D. AC Characteristics, $V_{DD} = 3.3V \pm 5\%$, $V_{DDO} = 1.5V \pm 5\%$, $T_A = 0^\circ C$ to $70^\circ C$

Parameter	Symbol	Test Conditions	Minimum	Typical	Maximum	Units
f_{MAX}	Output Frequency				350	MHz
t_{pLH}	Propagation Delay, Low to High	LVCMOS_CLK; NOTE 1A CLK/nCLK; NOTE 1B	2		4	ns
$t_{sk(o)}$	Output Skew; NOTE 2, 6	Measured on the Rising Edge			35	ps
$t_{sk(pp)}$	Part-to-Part Skew; NOTE 3, 6				1	ns
t_{jit}	Buffer Additive Phase Jitter, RMS; refer to Additive Phase Jitter Section, NOTE 5			0.04		ps
t_R / t_F	Output Rise/Fall Time; NOTE 4	20% to 80%	200		900	ps
odc	Output Duty Cycle	$f \leq 166MHz$	45		55	%
		$f > 166MHz$	42		58	%
t_{EN}	Output Enable Time; NOTE 4				5	ns
t_{DIS}	Output Disable Time; NOTE 4				5	ns

For NOTES, see Table 5C above.

Additive Phase Jitter

The spectral purity in a band at a specific offset from the fundamental compared to the power of the fundamental is called the ***dBc Phase Noise***. This value is normally expressed using a Phase noise plot and is most often the specified plot in many applications. Phase noise is defined as the ratio of the noise power present in a 1Hz band at a specified offset from the fundamental frequency to the power value of the fundamental. This ratio is expressed in decibels (dBm) or a ratio

of the power in the 1Hz band to the power in the fundamental. When the required offset is specified, the phase noise is called a ***dBc*** value, which simply means dBm at a specified offset from the fundamental. By investigating jitter in the frequency domain, we get a better understanding of its effects on the desired application over the entire time record of the signal. It is mathematically possible to calculate an expected bit error rate given a phase noise plot.

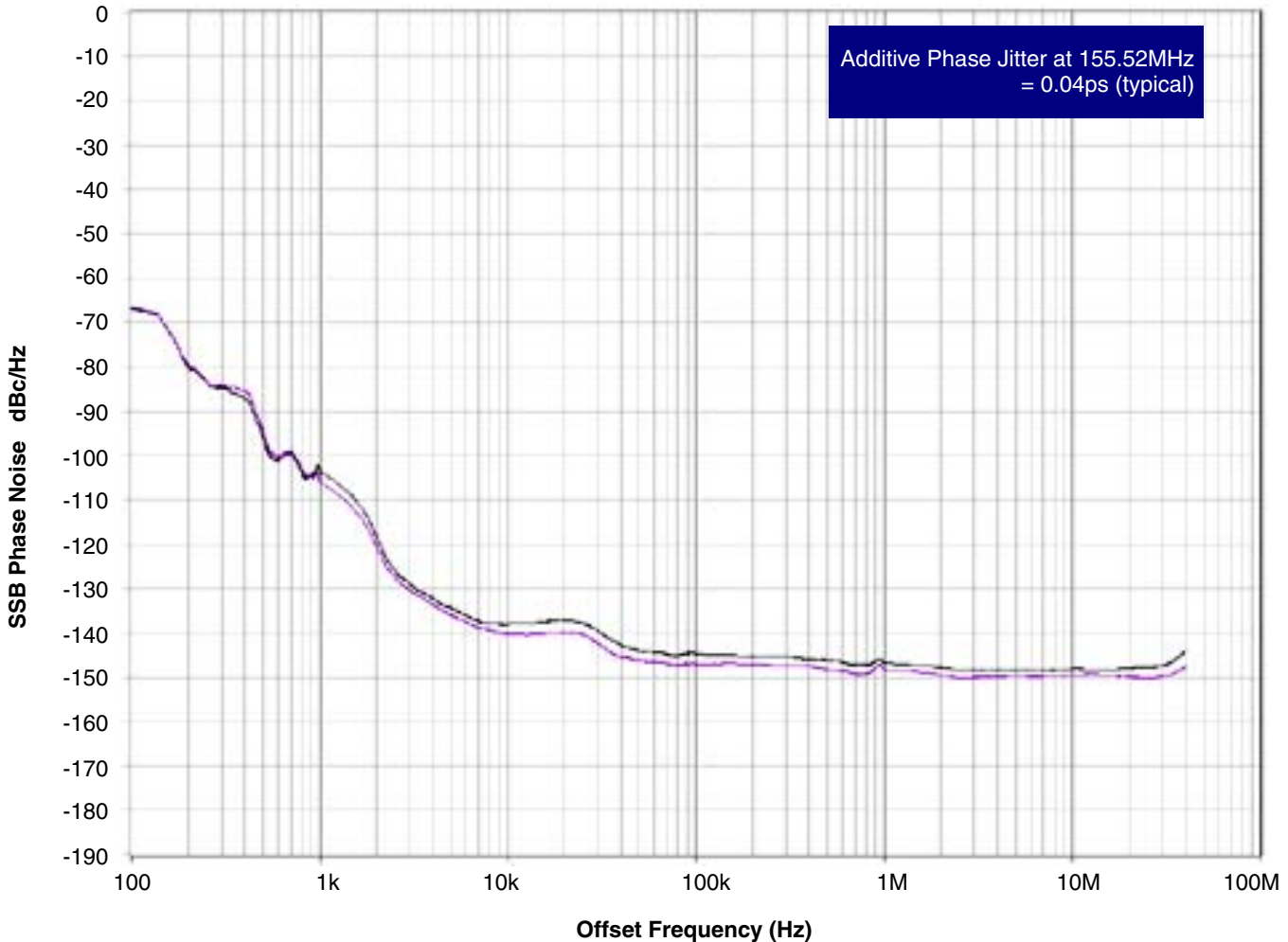

As with most timing specifications, phase noise measurements has issues relating to the limitations of the equipment. Often the noise floor of the equipment is higher than the noise floor of the device. This

is illustrated above. The device meets the noise floor of what is shown, but can actually be lower. The phase noise is dependent on the input source and measurement equipment.

Parameter Measurement Information

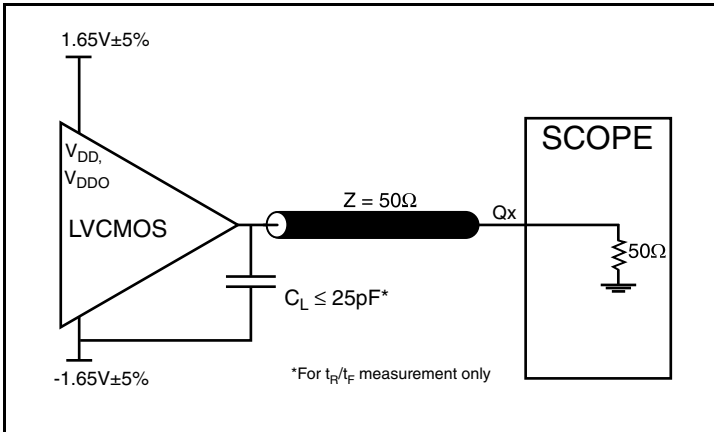

3.3V Core/3.3V LVCMOS Output Load AC Test Circuit

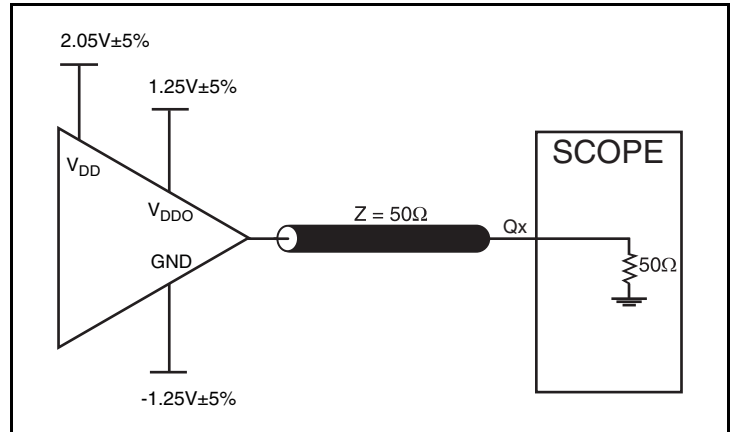

3.3V Core/2.5V LVCMOS Output Load AC Test Circuit

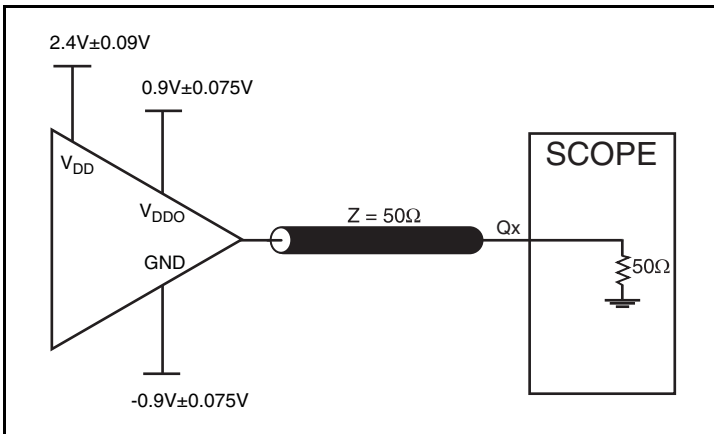

3.3V Core/1.8V LVCMOS Output Load AC Test Circuit

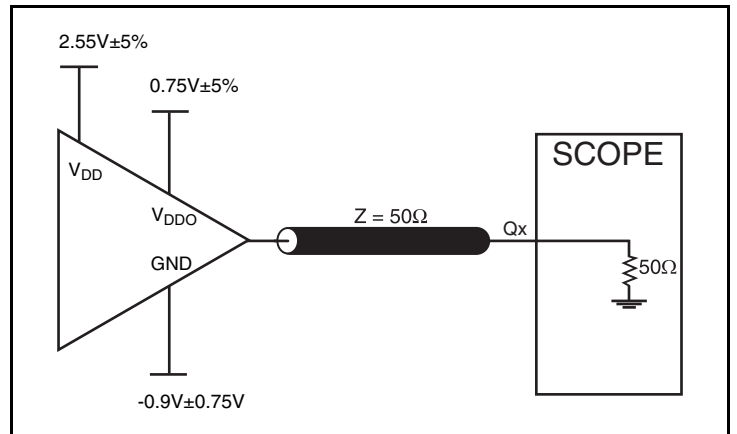

3.3V Core/1.5V LVCMOS Output Load AC Test Circuit

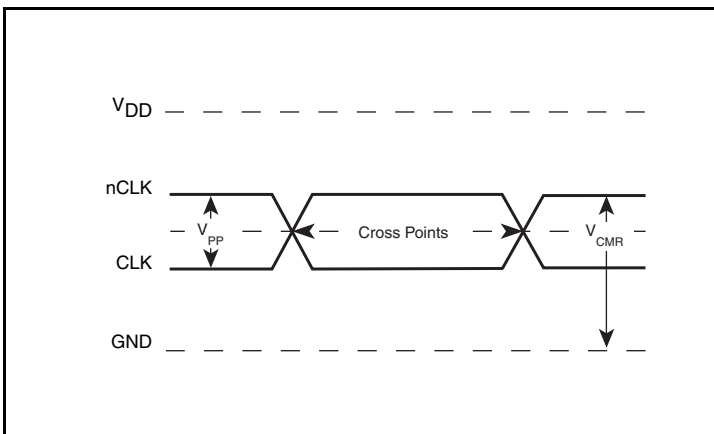

Differential Input Level

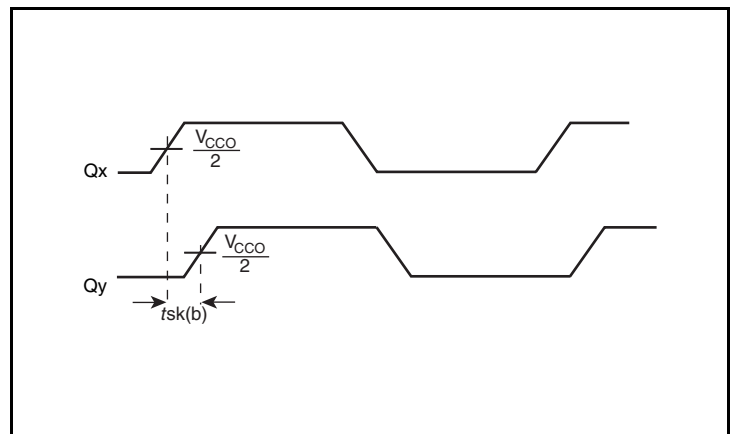

Output Skew

Parameter Measurement Information, continued

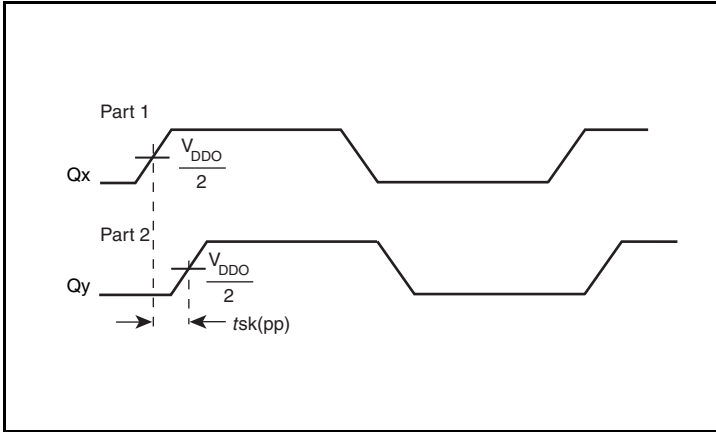

Part-to-Part Skew

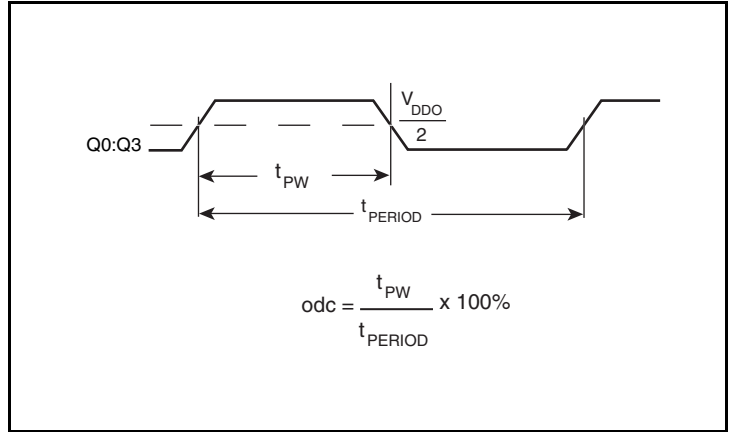

Output Duty Cycle/Pulse Width/Period

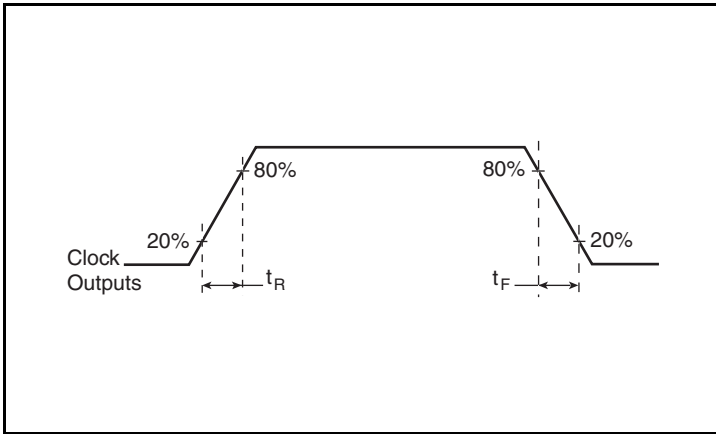

Output Rise/Fall Time

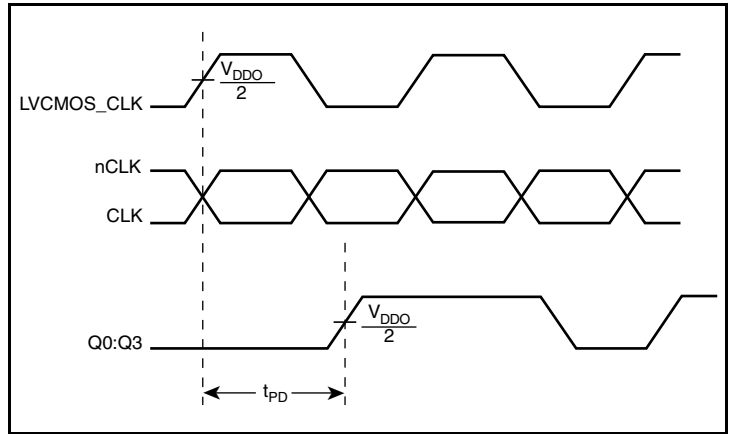

Propagation Delay

Application Information

Recommendations for Unused Input and Output Pins

Inputs:

LVCMOS_CLK Input

For applications not requiring the use of a clock input, it can be left floating. Though not required, but for additional protection, a 1k Ω resistor can be tied from the LVCMOS_CLK input to ground.

CLK/nCLK Inputs

For applications not requiring the use of the differential input, both CLK and nCLK can be left floating. Though not required, but for additional protection, a 1k Ω resistor can be tied from CLK to ground.

LVCMOS Control Pins

All control pins have internal pull-ups or pull-downs; additional resistance is not required but can be added for additional protection. A 1k Ω resistor can be used.

Outputs:

LVCMOS Outputs

All unused LVCMOS outputs can be left floating. There should be no trace attached.

Wiring the Differential Input to Accept Single Ended Levels

Figure 2 shows how a differential input can be wired to accept single ended levels. The reference voltage $V_1 = V_{DD}/2$ is generated by the bias resistors R1 and R2. The bypass capacitor (C1) is used to help filter noise on the DC bias. This bias circuit should be located as close to the input pin as possible. The ratio of R1 and R2 might need to be adjusted to position the V_1 in the center of the input voltage swing. For example, if the input clock swing is 2.5V and $V_{DD} = 3.3V$, R1 and R2 value should be adjusted to set V_1 at 1.25V. The values below are for when both the single ended swing and V_{DD} are at the same voltage. This configuration requires that the sum of the output impedance of the driver (R_o) and the series resistance (R_s) equals the transmission line impedance. In addition, matched termination at the input will attenuate the signal in half. This can be done in one of two ways. First, R3 and R4 in parallel should equal the transmission line

impedance. For most 50 Ω applications, R3 and R4 can be 100 Ω . The values of the resistors can be increased to reduce the loading for slower and weaker LVCMOS driver. When using single-ended signaling, the noise rejection benefits of differential signaling are reduced. Even though the differential input can handle full rail LVCMOS signaling, it is recommended that the amplitude be reduced. The datasheet specifies a lower differential amplitude, however this only applies to differential signals. For single-ended applications, the swing can be larger, however V_{IL} cannot be less than -0.3V and V_{IH} cannot be more than $V_{DD} + 0.3V$. Though some of the recommended components might not be used, the pads should be placed in the layout. They can be utilized for debugging purposes. The datasheet specifications are characterized and guaranteed by using a differential signal.

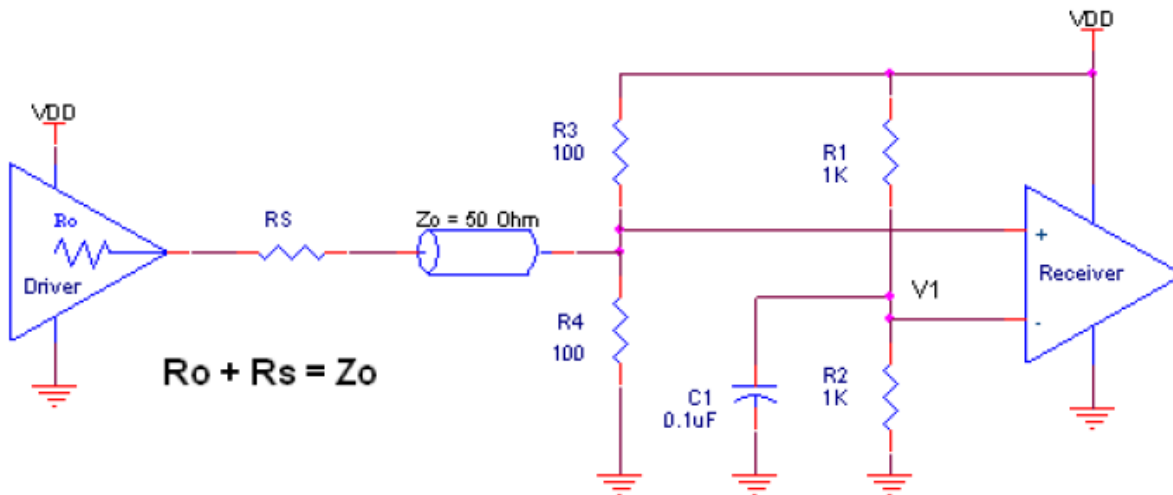

Figure 2. Recommended Schematic for Wiring a Differential Input to Accept Single-ended Levels

Differential Clock Input Interface

The CLK /nCLK accepts LVDS, LVPECL, LVHSTL, SSTL, HCSL and other differential signals. Both signals must meet the V_{PP} and V_{CMR} input requirements. Figures 3A to 3F show interface examples for the CLK/nCLK input driven by the most common driver types. The input interfaces suggested here are examples only. Please consult with the

vendor of the driver component to confirm the driver termination requirements. For example, in Figure 3A, the input termination applies for IDT open emitter LVHSTL drivers. If you are using an LVHSTL driver from another vendor, use their termination recommendation.

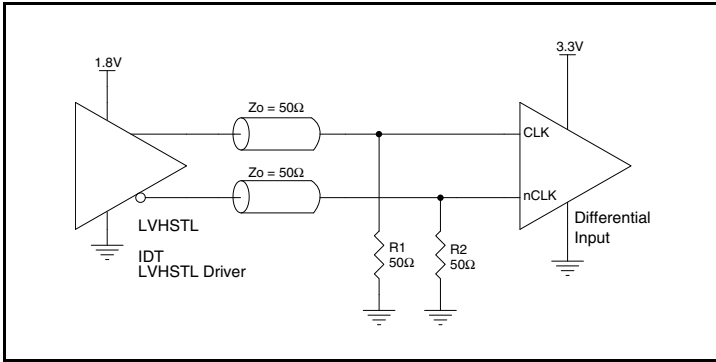

Figure 3A. CLK/nCLK Input Driven by an IDT Open Emitter LVHSTL Driver

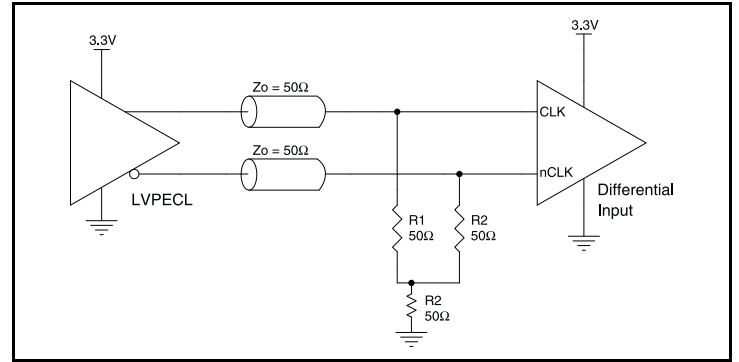

Figure 3B. CLK/nCLK Input Driven by a 3.3V LVPECL Driver

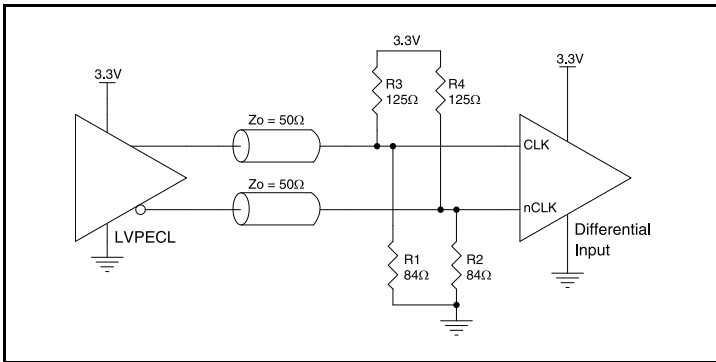

Figure 3C. CLK/nCLK Input Driven by a 3.3V LVPECL Driver

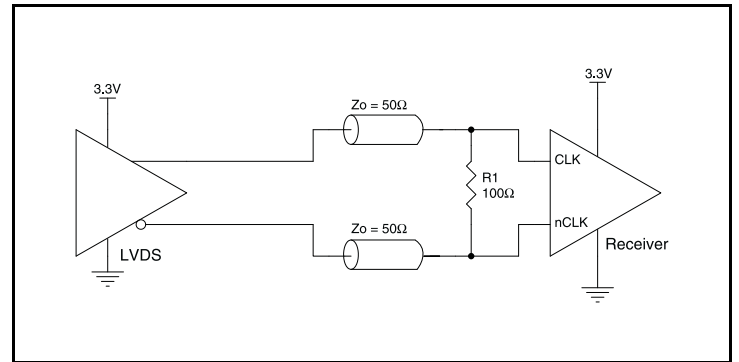

Figure 3D. CLK/nCLK Input Driven by a 3.3V LVDS Driver

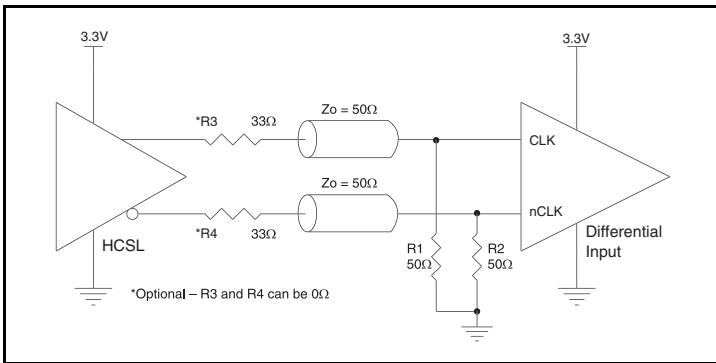

Figure 3E. CLK/nCLK Input Driven by a 3.3V HCSL Driver

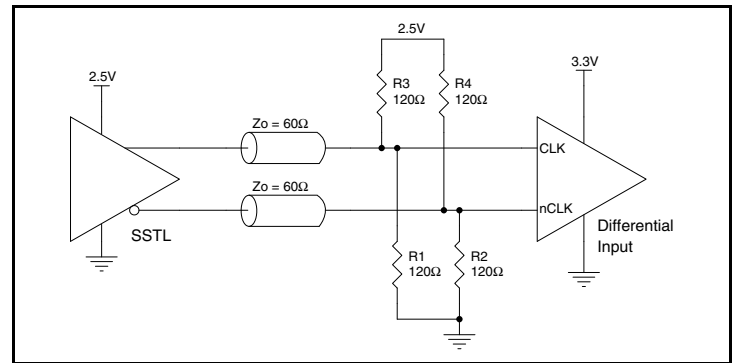

Figure 3F. CLK/nCLK Input Driven by a 2.5V SSTL Driver

Reliability Information

Table 6. θ_{JA} vs. Air Flow Table for a 16 Lead TSSOP

θ_{JA} vs. Air Flow			
Linear Feet per Minute	0	200	500
Single-Layer PCB, JEDEC Standard Test Boards	137.1°C/W	118.2°C/W	106.8°C/W
Multi-Layer PCB, JEDEC Standard Test Boards	89.0°C/W	81.8°C/W	78.1°C/W

NOTE: Most modern PCB design use multi-layered boards. The data in the second row pertains to most designs.

Transistor Count

The transistor count for ICS8305: 459

Package Outline and Package Dimensions

Package Outline - G Suffix for 16 Lead TSSOP

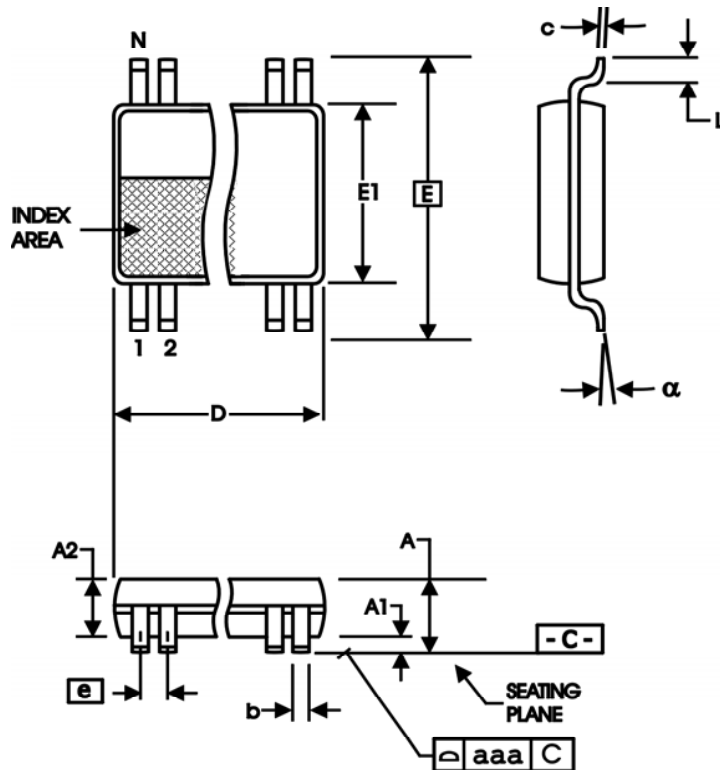

Table 7. Package Dimensions for 16 Lead TSSOP

All Dimensions in Millimeters		
Symbol	Minimum	Maximum
N	16	
A		1.20
A1	0.5	0.15
A2	0.80	1.05
b	0.19	0.30
c	0.09	0.20
D	4.90	5.10
E	6.40 Basic	
E1	4.30	4.50
e	0.65 Basic	
L	0.45	0.75
α	0°	8°
aaa		0.10

Reference Document: JEDEC Publication 95, MO-153

Ordering Information

Table 8. Ordering Information

Part/Order Number	Marking	Package	Shipping Packaging	Temperature
8305AGLF	8305AGLF	"Lead-Free" 16 Lead TSSOP	Tube	0°C to 70°C
8305AGLFT	8305AGLF	"Lead-Free" 16 Lead TSSOP	Tape & Reel	0°C to 70°C

Revision History Sheet

Rev	Table	Page	Description of Change	Date
A	T8	14	Ordering Information table - corrected Part/Order Number typo from ICS88305AGT to ICS8305AGT.	1/20/04
B	T5A - T5C	5 & 6 7	Added Additive Phase Jitter to AC Characteristics Tables. Added Additive Phase Jitter Section.	2/26/04
B	T1	2	Pin Description Table - corrected CLK_EN description.	12/6/04
C	T4A T4B T5D T8	1	Features Section - added 1.5V output to Supply Mode bullet and added Lead-Free bullet.	11/17/05
		4	Power Supply DC Characteristics Table - added V_{DDO} 1.5V.	
		4	LVC MOS DC Characteristics Table - added V_{OH}/V_{OL} 1.5V.	
		7	Added 3.3V/1.5V AC Characteristics Table.	
		10	Added 3.3V/1.5V Output Load AC Test Circuit Drawing.	
11	Added Recommendations for Unused Input and Output Pins.	16	Added Lead-Free part number.	
C	T8	15	Ordering Information Table - added lead-free marking. Corrected non-lead free marking from ICS8305AG to 8305AG.	2/22/08
C	T5A-T5D 8	1, 12	Updated to current datasheet format	9/17/12
		6, 7	Deleted HiPerClockS references.	
		11	Added Note: Electrical parameters are guaranteed ... to Notes	
15	Updated the 'Wiring the Differential Input to Accept Single Ended Levels' section Deleted: ICS from part numbers; quantity from shipping; LF Note; disclaimer.			
C	T8	1	Features Section - removed leaded part reference	5/30/14
		15	Ordering Information - removed leaded parts. PDN# CQ-13-02	
		17	Updated Technical Support contact email address	

We've Got Your Timing Solution



6024 Silver Creek Valley Road
San Jose, California 95138

Sales
800-345-7015 (inside USA)
+408-284-8200 (outside USA)
Fax: 408-284-2775
www.IDT.com/go/contactIDT

Technical Support
Clocks@idt.com
+480-763-2056

DISCLAIMER Integrated Device Technology, Inc. (IDT) and its subsidiaries reserve the right to modify the products and/or specifications described herein at any time and at IDT's sole discretion. All information in this document, including descriptions of product features and performance, is subject to change without notice. Performance specifications and the operating parameters of the described products are determined in the independent state and are not guaranteed to perform the same way when installed in customer products. The information contained herein is provided without representation or warranty of any kind, whether express or implied, including, but not limited to, the suitability of IDT's products for any particular purpose, an implied warranty of merchantability, or non-infringement of the intellectual property rights of others. This document is presented only as a guide and does not convey any license under intellectual property rights of IDT or any third parties.

IDT's products are not intended for use in applications involving extreme environmental conditions or in life support systems or similar devices where the failure or malfunction of an IDT product can be reasonably expected to significantly affect the health or safety of users. Anyone using an IDT product in such a manner does so at their own risk, absent an express, written agreement by IDT.

Integrated Device Technology, IDT and the IDT logo are registered trademarks of IDT. Other trademarks and service marks used herein, including protected names, logos and designs, are the property of IDT or their respective third party owners.

Copyright 2014. All rights reserved.

Looking for pricing, stock, or lifecycle information?

Click below to explore more details on WIN SOURCE:

- ⊖ [View ICS8305AGLFT on WIN SOURCE](#)
- ⊖ [IDT, Integrated Device Technology Inc Information](#)

Optimize Your Supply Chain with WIN SOURCE Solutions

- ✓ Global Sourcing Solution
- ✓ Obsolete Management
- ✓ Cost Control Management
- ✓ Shortage Management
- ✓ Alternative Solution
- ✓ Excess Inventory Management