



# THE DATASHEET OF P41-5.7S



# SWITCHING POWER MODULES

## UNIVERSAL INPUT

SINGLE/DUAL/TRIPLE OUTPUT, PC MOUNT/CHASSIS MOUNT

*P41, P61, P71 Series*



### FEATURES

- Universal Input Range 90-264VAC, 47-440 Hz
- PCB or Chassis Mount
- Fully Encapsulated Plastic Case
- Regulated Output
- Low Ripple and Noise
- Small Size But Higher Wattage
- Single, Dual and triple Outputs
- Over Voltage and Short Circuit Protection
- Meets UL 62368-1
- 3-Year Product Warranty

### ELECTRICAL SPECIFICATIONS

All specifications valid at normal input voltage, full load and +25°C after warm-up time unless otherwise stated.

Model No.	Single Output*	P41-33SA	P41-5SA	P41-7.35SA	P41-9SA	P41-12SA	P41-15SA	P41-24SA
	Max output wattage ( W )	14.85W	20W	20W	20W	20W	20W	20W
Output	Voltage (V.DC.)	3.3V	5V	7.35V	9V	12V	15V	24V
	Current (mA) max	4500	4000	2730	2230	1670	1340	840
	Voltage set accuracy	±2%	±2%	±2%	±2%	±2%	±2%	±2%
	Line Regulation (LL-HL) (typ.)	0.5%	0.5%	0.5%	0.5%	0.5%	0.5%	0.5%
	Load Regulation (0-100%) (typ.)	1%	1%	1%	1%	1%	1%	1%
	Minimum load	0%	0%	0%	0%	0%	0%	0%
	Efficiency (typ.)	75%	79%	82%	82%	83%	83%	84%
	Capacitor Load (max.)	25000 uF	13000 uF	2200 uF	1100 uF	920 uF	820 uF	600 uF

Model No.	Dual Output*	P61-5A		P61-12A		P61-15A	
	Max output wattage ( W )	20W		20W		20W	
Output		Output 1	Output 2	Output 1	Output 2	Output 1	Output 2
	Voltage (V.DC.)	+5V	-5V	+12V	-12V	+15V	-15V
	Current (mA) max	2000	2000	833	833	667	667
	Voltage set accuracy	±2%		±2%		±2%	
	Line Regulation (LL-HL) (typ.)	±0.5%		±0.5%		±0.5%	
	Load Regulation (10-100%) (typ.)	±3%		±3%		±3%	
	Minimum load	0%		0%		0%	
	Efficiency (typ.)	79%		82%		82%	
	Capacitor Load (max.)	±4300 uF		±560 uF		±220 uF	

Model No.	Triple Output*	P71-12A			P71-15A		
	Max output wattage ( W )	20W			20W		
Output		Output 2	Output 3	Output 1	Output 2	Output 3	
	Voltage (V.DC.)	+12	-12	5	+15	-15	
	Current (mA) max	250	250	2800	200	200	
	Voltage set accuracy	±5%			±2%	±5%	
	Line Regulation (LL-HL) (typ.)	5%			1%	5%	
	Load Regulation (20-100%) (typ.)	5%			2%	5%	
	Minimum load	10%			10%		
	Efficiency (typ.)	81%			81%		
	Capacitor Load (max.)	3500 uF / ±220 uF			3500 uF / ±150 uF		

\*For Chassis Mount with terminal strip, use suffix "T" after Model Number.

All specifications valid at normal input voltage, full load and +25°C after warm-up time unless otherwise stated.

Input	Voltage	90-264 VAC or 100-375 VDC
	Frequency (Hz)	47-440 Hz
	Current (Full load)	400 mA max. (115 VAC) / 270 mA max. (230 VAC)
	Inrush current (<2ms)	30 A max. (115 VAC) / 50 A max. (230 VAC)
	Leakage Current	0.25 mA
	External Fuse (recommend)	2 A slow blow type
	Power Saving	230V < 0.5W (except 24S)
Output	Ripple	<0.2% Vout +40mV max (Vp-p)
	Noise	<0.5% Vout +50mV max (Vp-p)
	Hold-up time (typ.)	13 ms min.
Protection	Over current protection	Above 105% rated output power
	Over voltage protection	Zener diode clamp
	Short circuit protection	Hiccup mode (automatic recovery)
Isolation	Input-Output (V.AC)	3000V
	Input-FG (V.AC)	3000V
	Output-FG (V.AC)	500V
Environment	Operating temperature	-25°C...+70°C (with derating)
	Storage temperature	-40°C...+85°C
	Temperature coefficient	0.02%/°C
	Humidity	95% RH
	MTBF	>400,000 h @ 25°C (MIL-HDBK-217F)
Physical	Dimensions (L x W x H)	2.73 x 1.87 x 0.85 Inches ( 69.5 x 47.5 x 21.7 mm ) Tolerance ±0.5 mm
	Case Material	Plastic resin (flammability to UL 94V-0)
	Weight	110 g
	Cooling method	Free air convection
Safety	Designed to meet	IEC / EN 60950, UL / IEC / EN 62368-1
EMC	EMI (Conducted & Radiated Emission)	EN 55032 class B
	EMS (Noise Immunity)	EN 55024

## NOTE

- Ripple & Noise are measured at 20MHz of bandwidth with 0.1uF & 47uF parallel capacitor.
- The triple output required a minimum 10% loading on the output to maintain specified regulation.  
Operation under no-load condition will not damage these devices; however they may not meet all listed specification.
- Load regulation for triple output:  
Main output (V1): 20% to 100% with 20% to 100% balanced on auxiliaries.  
Auxiliary outputs (V2 and V3): 20% to 100% balanced on all outputs.
- Cross regulation for dual output: asymmetrical load 25% / 100% FL  
Cross regulation for triple output:  
Main output 100% load, auxiliary 100%, other auxiliary 25% to 100%.  
Auxiliary outputs (V2 and V3): main output 100% load, auxiliary 100%,  
other auxiliary 25% to 100% or main output 25%, auxiliary 25%, other auxiliary 25% to 100%.
- It's necessary Varistor 14S471K at L / N input side in parallel.

### MECHANICAL DIMENSIONS ( Top View )

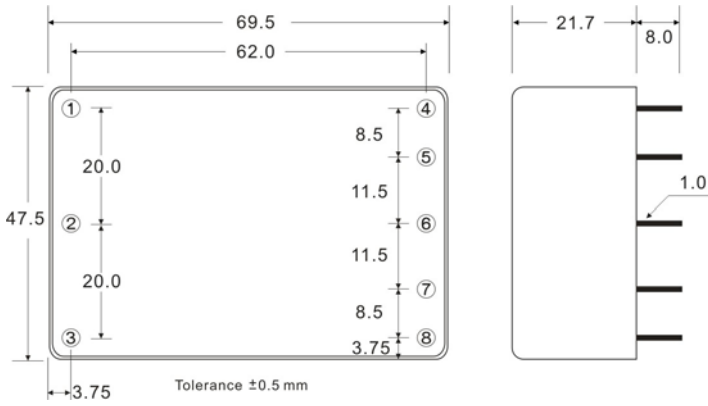

PIN#	Single	Dual	Triple
1	FG	FG	FG
2	AC IN (N)	AC IN (N)	AC IN (N)
3	AC IN (L)	AC IN (L)	AC IN (L)
4	NO PIN	NO PIN	-DC OUT
5	-DC OUT	-DC OUT	COMMON
6	NO PIN	COMMON	+DC OUT
7	+DC OUT	+DC OUT	+5V RTN
8	NO PIN	NO PIN	+5V OUT

### BLOCK DIAGRAM

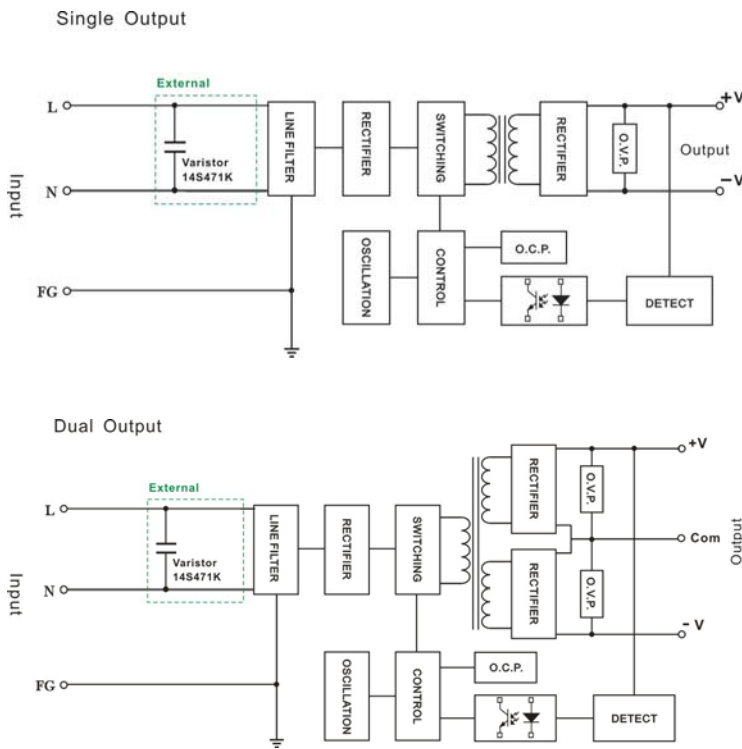

### DERATING

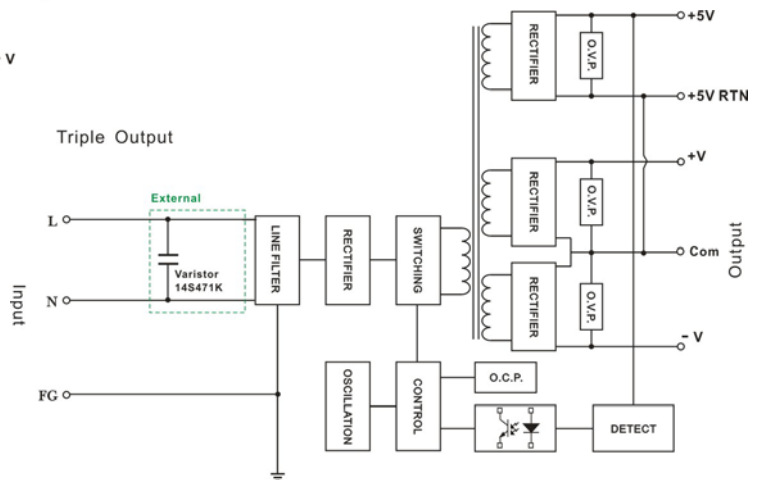
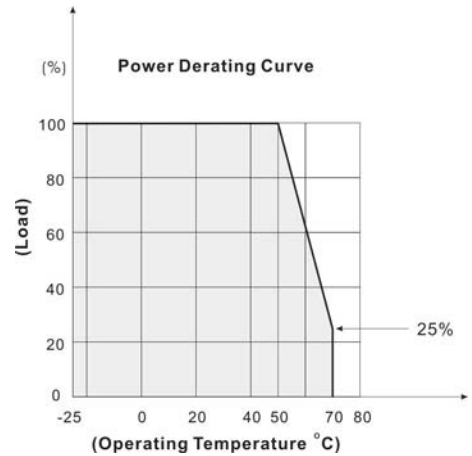

**SCREW TERMINAL**



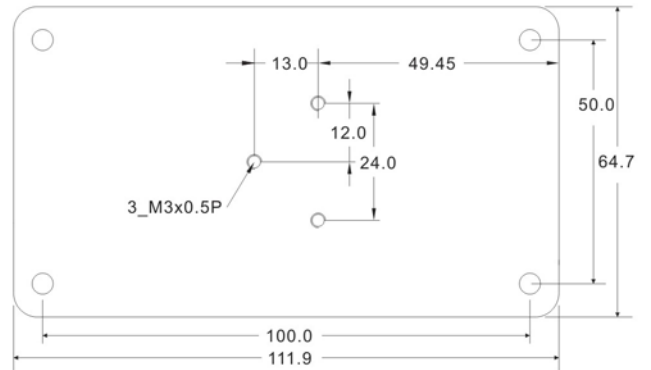
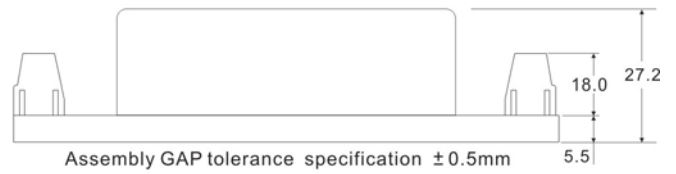

Case CAT

PIN#	Single	Dual	Triple
1	FG	FG	FG
2	AC IN (N)	AC IN (N)	AC IN (N)
3	AC IN (L)	AC IN (L)	AC IN (L)
4	NO CONNECT	NO CONNECT	-DC OUT
5	-DC OUT	-DC OUT	COMMON
6	NO CONNECT	COMMON	+DC OUT
7	+DC OUT	+DC OUT	+5V RTN
8	NO CONNECT	NO CONNECT	+5V OUT



## Looking for pricing, stock, or lifecycle information?

Click below to explore more details on WIN SOURCE:

-  [View P41-5.7S on WIN SOURCE](#)
-  [Polytronics Technology Corp Information](#)

## Optimize Your Supply Chain with WIN SOURCE Solutions

-  Global Sourcing Solution
-  Obsolete Management
-  Cost Control Management
-  Shortage Management
-  Alternative Solution
-  Excess Inventory Management