



**THE DATASHEET OF
ICL3245ECAZ-T**



ICL3225E, ICL3227E, ICL3245E

±15kV ESD Protected, +3V to +5.5V, 1µA, 1Mbps, RS-232 Transceivers with Enhanced Automatic Powerdown

The [ICL3225E](#), [ICL3227E](#), and [ICL3245E](#) devices are 3.0V to 5.5V powered RS-232 transmitters/receivers that meet EIA/TIA-232 and V.28/V.24 specifications, even at $V_{CC} = 3.0V$. They provide ±15kV ESD protection (IEC61000-4-2 Air Gap and Human Body Model) on transmitter outputs and receiver inputs (RS-232 pins). Targeted applications are PDAs, Palmtops, and notebook and laptop computers where the low operational power consumption and even lower standby power consumption are critical. Efficient on-chip charge pumps coupled with manual and enhanced automatic powerdown functions, reduce the standby supply current to a 1µA trickle. Small footprint packaging and the use of small, low value capacitors ensure board space savings. Data rates greater than 1Mbps are ensured at worst case load conditions. This family is fully compatible with 3.3V only systems, mixed 3.3V and 5.0V systems, and 5.0V only systems.

The ICL3245E is a 3-driver, 5-receiver device that provides a complete serial port suitable for laptop or notebook computers. It also includes a noninverting always-active receiver for “wake-up” capability.

The ICL3225E, ICL3227E, and ICL3245E feature an enhanced automatic powerdown function that powers down the on-chip power supply and driver circuits. Powerdown occurs when all receiver and transmitter inputs detect no signal transitions for a period of 30s. These devices power back up automatically whenever they sense a transition on any transmitter or receiver input.

[Table 1](#) summarizes the features of the device represented by this datasheet and [AN9863](#) summarizes the features of each device in the ICL32xxE 3V family.

Related Literature

For a full list of related documents, visit our website:

- [ICL3225E](#), [ICL3227E](#), and [ICL3245E](#) device pages

Features

- Pb-free (RoHS compliant)
- ESD protection for RS-232 I/O pins to ±15kV (IEC61000)
- Manual and enhanced automatic powerdown features
- Drop in replacements for MAX3225E, MAX3227E, MAX3245E
- RS-232 compatible with $V_{CC} = 2.7V$
- Meets EIA/TIA-232 and V.28/V.24 specifications at 3V
- Latch-up free
- On-chip voltage converters require only four external 0.1µF capacitors
- Ensured mouse driveability (ICL3245E)
- “Ready to Transmit” indicator output (ICL3225E/ICL3227E)
- Receiver hysteresis for improved noise immunity
- Ensured minimum data rate: 1Mbps
- Low skew at transmitter/receiver input trip points: 10ns
- Ensured minimum slew rate: 24V/µs
- Wide power supply range: single +3V to +5.5V
- Low supply current in powerdown state: 1µA

Applications

- Any system requiring RS-232 communication ports
 - Battery powered, hand-held, and portable equipment
 - Laptop computers, notebooks, palmtops
 - Modems, printers, and other peripherals
 - Digital cameras
 - Cellular/mobile phones

Contents

1. Overview	3
1.1 Typical Operating Circuits	3
1.2 Ordering Information	5
1.3 Pin Configurations	5
1.4 Pin Descriptions	6
2. Specifications	7
2.1 Absolute Maximum Ratings	7
2.2 Thermal Information	7
2.3 Recommended Operating Conditions	7
2.4 Electrical Specifications	8
3. Typical Performance Curves	10
4. Application Information	12
4.1 Charge Pump	12
4.1.1 Charge Pump Abs Max Ratings	12
4.2 Transmitters	13
4.3 Receivers	14
4.4 Powerdown Functionality	15
4.4.1 Software Controlled (Manual) Powerdown	16
4.4.2 <u>INVALID</u> Output	16
4.4.3 Enhanced Automatic Powerdown	17
4.4.4 Emulating Standard Automatic Powerdown	18
4.4.5 Hybrid Automatic Powerdown Options	19
4.5 READY Output (ICL3225E and ICL3227E Only)	19
4.6 Capacitor Selection	19
4.7 Power Supply Decoupling	19
4.8 Operation Down to 2.7V	19
4.9 Transmitter Outputs when Exiting Powerdown	19
4.10 Mouse Driveability	20
4.11 High Data Rates	20
4.12 Interconnection with 3V and 5V Logic	21
5. ±15kV ESD Protection	22
5.1 Human Body Model (HBM) Testing	22
5.2 IEC61000-4-2 Testing	22
5.3 Air-Gap Discharge Test Method	22
5.4 Contact Discharge Test Method	22
6. Die Characteristics	23
7. Revision History	24
8. Package Outline Drawings	25

1. Overview

1.1 Typical Operating Circuits

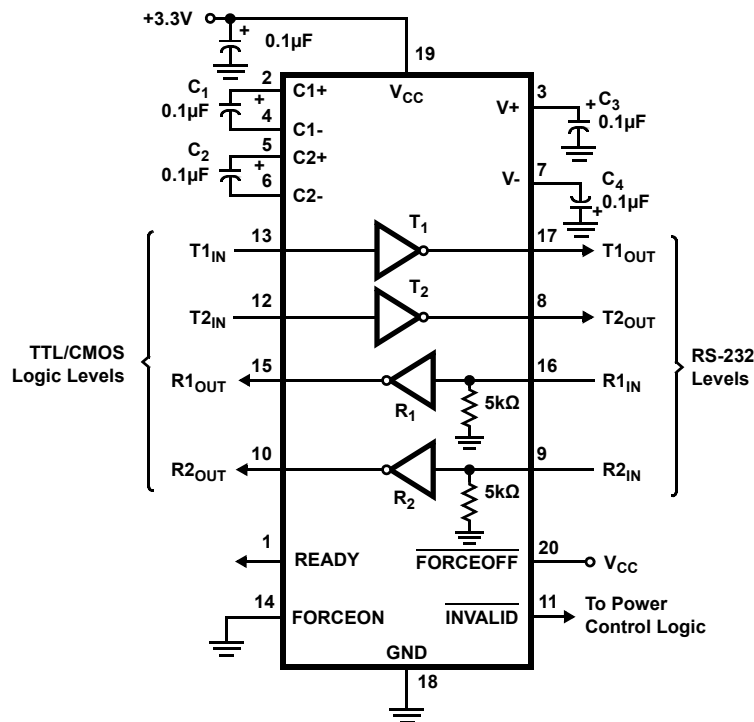

Figure 1. ICL3225E

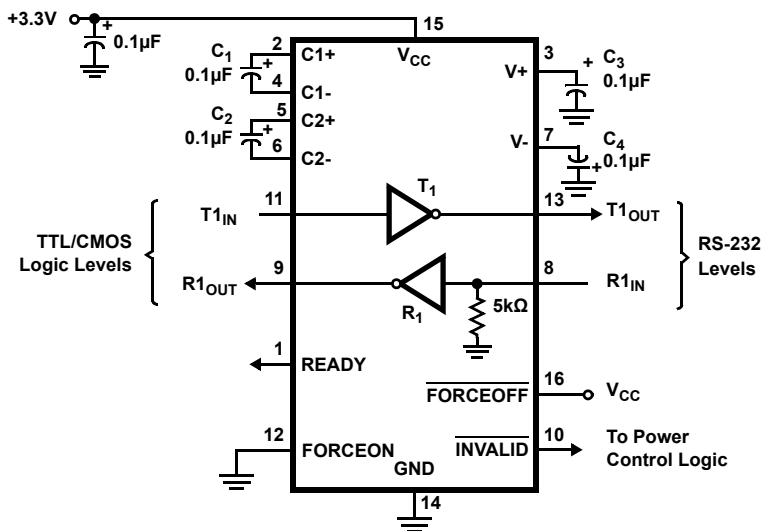

Figure 2. ICL3227E

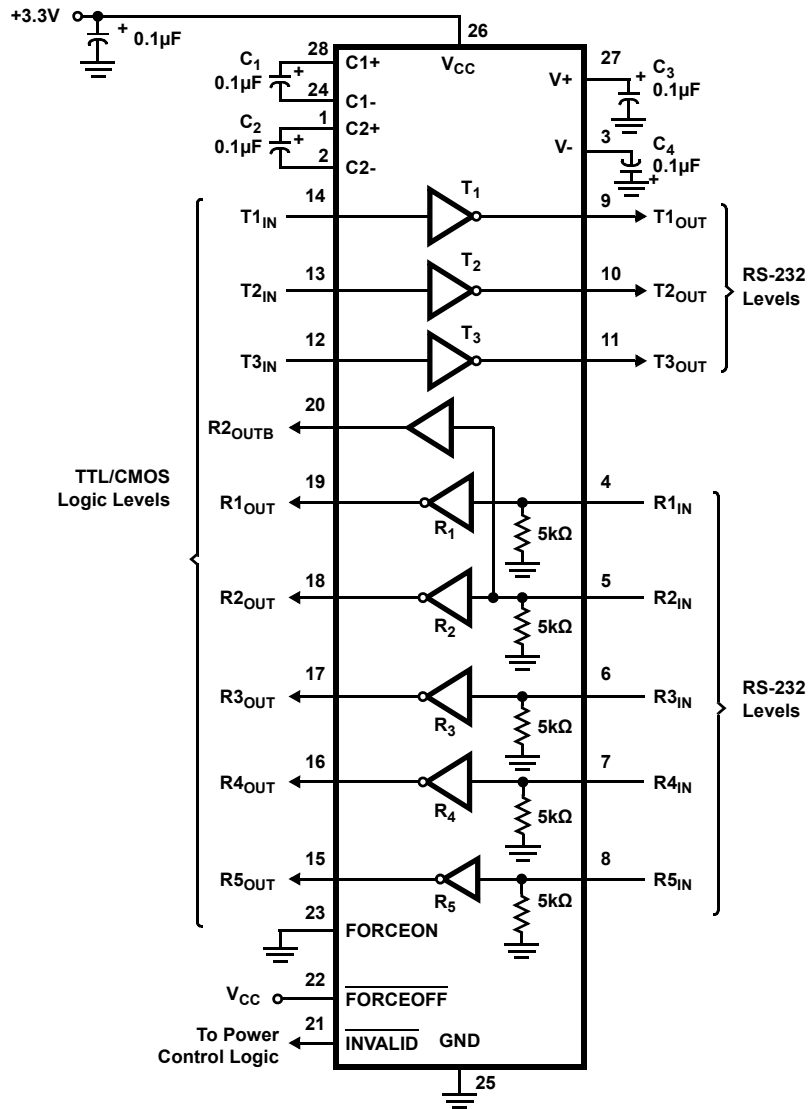

Figure 3. ICL3245E

1.2 Ordering Information

Part Number (Notes 2, 3)	Part Marking	Temp Range (°C)	Tape and Reel (Units) (Note 1)	Package (RoHS Compliant)	Pkg. Dwg. #
ICL3225ECAZ	ICL3225ECAZ	0 to +70	-	20 Ld SSOP	M20.209
ICL3225ECAZ-T	ICL3225ECAZ	0 to +70	1k	20 Ld SSOP	M20.209
ICL3225EIAZ	ICL3225EIAZ	-40 to +85	-	20 Ld SSOP	M20.209
ICL3225EIAZ-T	ICL3225EIAZ	-40 to +85	1k	20 Ld SSOP	M20.209
ICL3227ECAZA	3227ECAZ	0 to +70	-	16 Ld SSOP	M16.209
ICL3227ECAZA-T	3227ECAZ	0 to +70	1k	16 Ld SSOP	M16.209
ICL3227EIAZA	3227EIAZ	-40 to +85	-	16 Ld SSOP	M16.209
ICL3227EIAZA-T	3227EIAZ	-40 to +85	1k	16 Ld SSOP	M16.209
ICL3245ECAZ	ICL3245ECAZ	0 to +70	-	28 Ld SSOP	M28.209
ICL3245ECAZ-T	ICL3245ECAZ	0 to +70	1k	28 Ld SSOP	M28.209
ICL3245EIAZ	ICL3245EIAZ	-40 to +85	-	28 Ld SSOP	M28.209
ICL3245EIAZ-T	ICL3245EIAZ	-40 to +85	1k	28 Ld SSOP	M28.209

Notes:

- See [TB347](#) for details about reel specifications.
- These Pb-free plastic packaged products employ special Pb-free material sets, molding compounds/die attach materials, and 100% matte tin plate plus anneal (e3 termination finish, which is RoHS compliant and compatible with both SnPb and Pb-free soldering operations). Pb-free products are MSL classified at Pb-free peak reflow temperatures that meet or exceed the Pb-free requirements of IPC/JEDEC J-STD-020.
- For Moisture Sensitivity Level (MSL), see the [ICL3225E](#), [ICL3227E](#), and [ICL3245E](#) device pages. For more information about MSL, see [TB363](#).

Table 1. Summary of Features

Part Number	Number of Tx.	Number of Rx.	Number of Monitor Rx. (R _{OUTB})	Data Rate (kbps)	Rx. Enable Function?	Ready Output?	Manual Powerdown?	Enhanced Automatic Powerdown Function?
ICL3225E	2	2	0	1000	No	Yes	Yes	Yes
ICL3227E	1	1	0	1000	No	Yes	Yes	Yes
ICL3245E	3	5	1	1000	No	No	Yes	Yes

1.3 Pin Configurations

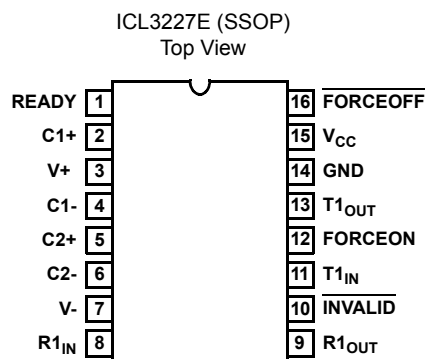
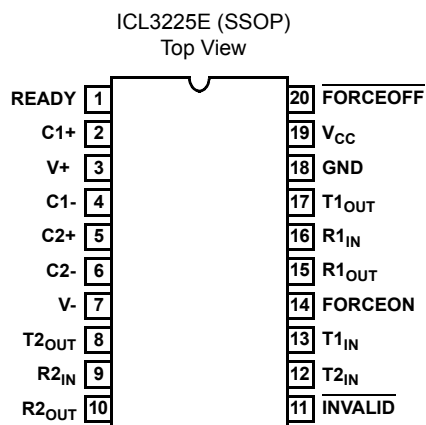

ICL3245E (SSOP)
Top View

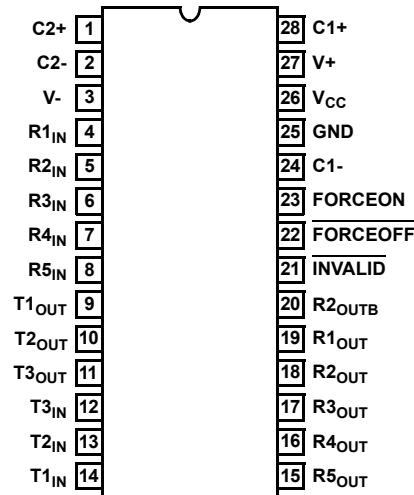

1.4 Pin Descriptions

Pin	Function
V _{CC}	System power supply input (3.0V to 5.5V).
V+	Internally generated positive transmitter supply (+5.5V).
V-	Internally generated negative transmitter supply (-5.5V).
GND	Ground connection.
C1+	External capacitor (voltage doubler) is connected to this lead.
C1-	External capacitor (voltage doubler) is connected to this lead.
C2+	External capacitor (voltage inverter) is connected to this lead.
C2-	External capacitor (voltage inverter) is connected to this lead.
T _{XIN}	TTL/CMOS compatible transmitter Inputs.
T _{XOUT}	±15kV ESD protected, RS-232 level (nominally ±5.5V) transmitter outputs.
R _{XIN}	±15kV ESD protected, RS-232 compatible receiver inputs.
R _{XOUT}	TTL/CMOS level receiver outputs.
R2 _{OUTB}	TTL/CMOS level, noninverting, always enabled receiver outputs.
$\overline{\text{INVALID}}$	Active low output that indicates if no valid RS-232 levels are present on any receiver input.
READY	Active high output that indicates when the ICL32xxE is ready to transmit ($V- \leq -4V$).
$\overline{\text{FORCEOFF}}$	Active low to shut down transmitters and on-chip power supply, which overrides any automatic circuitry and FORCEON (see Table 5 on page 15).
FORCEON	Active high input to override automatic powerdown circuitry and keeps transmitters active. ($\overline{\text{FORCEOFF}}$ must be high).

2. Specifications

2.1 Absolute Maximum Ratings

Parameter	Minimum	Maximum	Unit
V _{CC} to GND	-0.3	6	V
V+ to GND	-0.3	7	V
V- to GND	+0.3	-7	V
V+ to V-		14	V
Input Voltages			
T _{IN} , FORCEOFF, FORCEON	-0.3	6	V
R _{IN}		±25	V
Output Voltages			
T _{OUT}		±13.2	V
R _{OUT} , INVALID, READY	-0.3	V _{CC} +0.3	V
Short-Circuit Duration			
T _{OUT}		Continuous	
ESD Rating	(See “ESD Performance” on page 9)		

CAUTION: Do not operate at or near the maximum ratings listed for extended periods of time. Exposure to such conditions can adversely impact product reliability and result in failures not covered by warranty.

2.2 Thermal Information

Thermal Resistance (Typical, Note 4)	θ_{JA} (°C/W)
16 Ld SSOP Package	145
20 Ld SSOP Package	135
28 Ld SSOP Package	100

Notes:

- θ_{JA} is measured with the component mounted on a low-effective thermal conductivity test board in free air. See [TB379](#) for details.

Parameter	Minimum	Maximum	Unit
Maximum Junction Temperature (Plastic Package)		+150	°C
Maximum Storage Temperature Range	-65	+150	°C
Pb-Free Reflow Profile	see TB493		

2.3 Recommended Operating Conditions

Parameter	Minimum	Maximum	Unit
Temperature Range			
ICL32xxEC	0	+70	°C
ICL32xxEI	-40	+85	°C

2.4 Electrical Specifications

Test conditions: $V_{CC} = 3V$ to $5.5V$, $C_1 - C_4 = 0.1\mu F$; unless otherwise specified. Typical values are at $T_A = +25^\circ C$

Parameter	Test Conditions	Temp (°C)	Min	Typ	Max	Unit	
DC Characteristics							
Supply Current, Automatic Powerdown	All R_{IN} open, $FORCEON = GND$, $\overline{FORCEOFF} = V_{CC}$	+25	-	1.0	10	μA	
Supply Current, Powerdown	$\overline{FORCEOFF} = GND$	+25	-	1.0	10	μA	
Supply Current, Automatic Powerdown Disabled	All outputs unloaded, $FORCEON = \overline{FORCEOFF} = V_{CC}$	+25	-	0.3	1.0	mA	
Logic and Transmitter Inputs and Receiver Outputs							
Input Logic Threshold Low	T_{IN} , $FORCEON$, $\overline{FORCEOFF}$	Full	-	-	0.8	V	
Input Logic Threshold High	T_{IN} , $FORCEON$, $\overline{FORCEOFF}$	$V_{CC} = 3.3V$	Full	2.0	-	-	V
		$V_{CC} = 5.0V$	Full	2.4	-	-	V
Input Leakage Current	T_{IN} , $FORCEON$, $\overline{FORCEOFF}$	Full	-	± 0.01	± 1.00	μA	
Output Leakage Current	$\overline{FORCEOFF} = GND$, ICL3245E only	Full	-	± 0.05	± 10	μA	
Output Voltage Low	$I_{OUT} = 1.6mA$	Full	-	-	0.4	V	
Output Voltage High	$I_{OUT} = -1.0mA$	Full	$V_{CC} - 0.6$	$V_{CC} - 0.1$	-	V	
Receiver Inputs							
Input Voltage Range		Full	-25	-	25	V	
Input Threshold Low	$V_{CC} = 3.3V$	+25	0.6	1.2	-	V	
	$V_{CC} = 5.0V$	+25	0.8	1.5	-	V	
Input Threshold High	$V_{CC} = 3.3V$	+25	-	1.5	2.4	V	
	$V_{CC} = 5.0V$	+25	-	1.8	2.4	V	
Input Hysteresis		+25	-	0.5	-	V	
Input Resistance		+25	3	5	7	k Ω	
Transmitter Outputs							
Output Voltage Swing	All transmitter outputs loaded with 3k Ω to Ground	Full	± 5.0	± 5.4	-	V	
Output Resistance	$V_{CC} = V_+ = V_- = 0V$, transmitter output = $\pm 2V$	Full	300	10M	-	Ω	
Output Short-Circuit Current		Full	-	± 35	± 60	mA	
Output Leakage Current	$V_{OUT} = \pm 12V$, $V_{CC} = 0V$ or $3V$ to $5.5V$, automatic powerdown or $\overline{FORCEOFF} = GND$	Full	-	-	± 25	μA	
Mouse Driveability							
Transmitter Output Voltage (See Figure 20 on page 20)	$T1_{IN} = T2_{IN} = GND$, $T3_{IN} = V_{CC}$, $T3_{OUT}$ loaded with 3k Ω to GND, $T1_{OUT}$ and $T2_{OUT}$ loaded with 2.5mA each	Full	± 5	-	-	V	
Enhanced Automatic Powerdown (FORCEON = GND, FORCEOFF = VCC)							
Receiver Input Thresholds to INVALID High	See Figure 15 on page 17	Full	-2.7	-	2.7	V	
Receiver Input Thresholds to INVALID Low	See Figure 15 on page 17	Full	-0.3	-	0.3	V	
INVALID, READY Output Voltage Low	$I_{OUT} = 1.6mA$	Full	-	-	0.4	V	
INVALID, READY Output Voltage High	$I_{OUT} = -1.0mA$	Full	$V_{CC} - 0.6$	-	-	V	
Receiver Positive or Negative Threshold to INVALID High Delay (t_{INVH})		+25	-	1	-	μs	

Test conditions: $V_{CC} = 3V$ to $5.5V$, $C_1 - C_4 = 0.1\mu F$; unless otherwise specified. Typical values are at $T_A = +25^\circ C$ (Continued)

Parameter	Test Conditions		Temp (°C)	Min	Typ	Max	Unit
Receiver Positive or Negative Threshold to INVALID Low Delay ($t_{INV L}$)			+25	-	30	-	μs
Receiver or Transmitter Edge to Transmitters Enabled Delay (t_{WU})	(Note 5)		25	-	100	-	μs
Receiver or Transmitter Edge to Transmitters Disabled Delay ($t_{AUTOPWDN}$)	(Note 5)		Full	15	30	60	sec
Timing Characteristics							
Maximum Data Rate	$R_L = 3k\Omega$, one transmitter switching	$C_L = 1000pF$	Full	250	-	-	kbps
		$V_{CC} = 3V$ to $4.5V$, $C_L = 250pF$	Full	1000	-	-	kbps
		$V_{CC} = 4.5V$ to $5.5V$, $C_L = 1000pF$	Full	1000	-	-	kbps
Receiver Propagation Delay	Receiver input to receiver output, $C_L = 150pF$	t_{PHL}	+25	-	0.15	-	μs
		t_{PLH}	+25	-	0.15	-	μs
Receiver Output Enable Time	Normal operation (ICL3245E only)		+25	-	200	-	ns
Receiver Output Disable Time	Normal operation (ICL3245E only)		+25	-	200	-	ns
Transmitter Skew	$t_{PHL} - t_{PLH}$ (Note 6)		+25	-	25	-	ns
Receiver Skew	$t_{PHL} - t_{PLH}$ (Note 6)		+25	-	50	-	ns
Transition Region Slew Rate	$V_{CC} = 3.3V$, $R_L = 3k\Omega$ to $7k\Omega$, measured from $3V$ to $-3V$ or $-3V$ to $3V$, $C_L = 150pF$ to $1000pF$		+25	24	-	150	$V/\mu s$
ESD Performance							
RS-232 Pins (T_{OUT} , R_{IN})	Human body model		+25	-	± 15	-	kV
	IEC61000-4-2 contact discharge		+25	-	± 8	-	kV
	IEC61000-4-2 air gap discharge		+25	-	± 15	-	kV
All Other Pins	ICL3245E	Human body model (HBM)	+25	-	± 2	-	kV
		Charged Device Model (CDM)	+25	-	± 1.5	-	kV
	ICL3225E, ICL3227E	Human body model (HBM)	+25	-	± 4	-	kV
		Charged Device Model (CDM)	+25	-	± 2	-	kV

Notes:

5. An "edge" is defined as a transition through the transmitter or receiver input thresholds.
6. Skews are measured at the receiver input switching points (1.4V).

3. Typical Performance Curves

$V_{CC} = 3.3V, T_A = +25^\circ C$

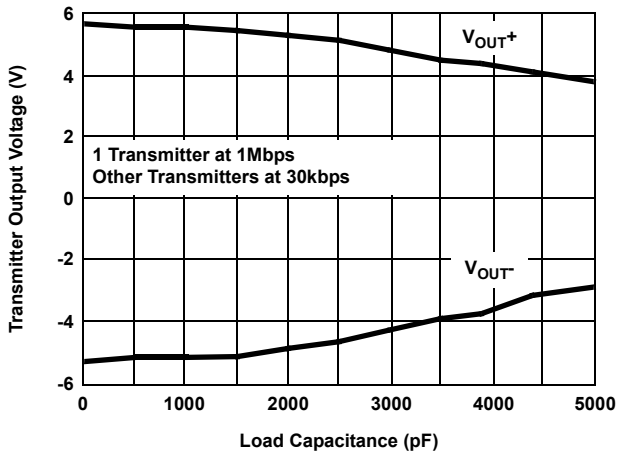

Figure 4. Transmitter Output Voltage vs Load Capacitance

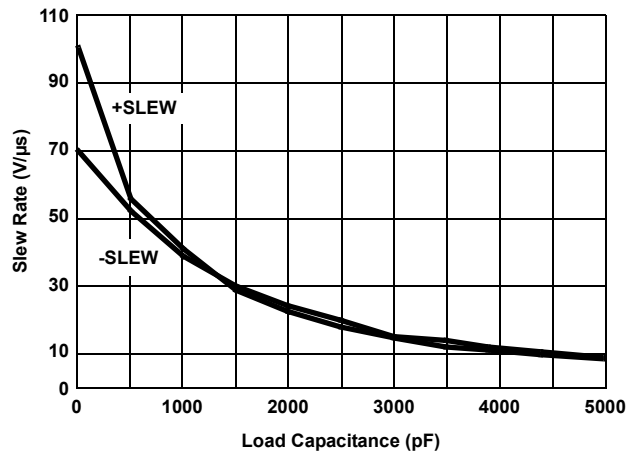

Figure 5. Slew Rate vs Load Capacitance

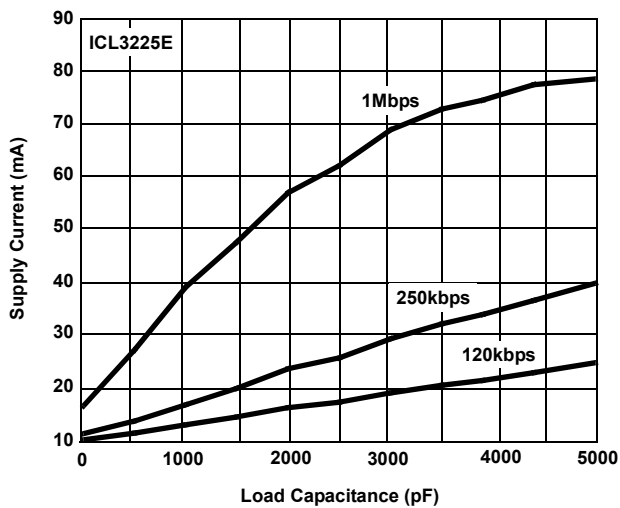

Figure 6. Supply Current vs Load Capacitance When Transmitting Data

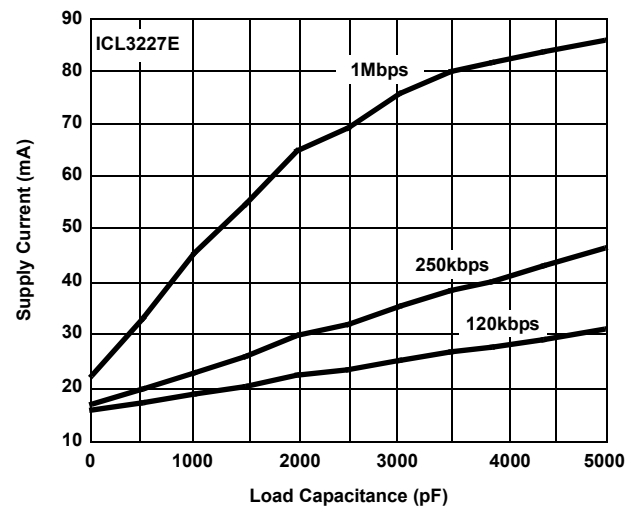

Figure 7. Supply Current vs Load Capacitance When Transmitting Data

$V_{CC} = 3.3V$, $T_A = +25^\circ C$ (Continued)

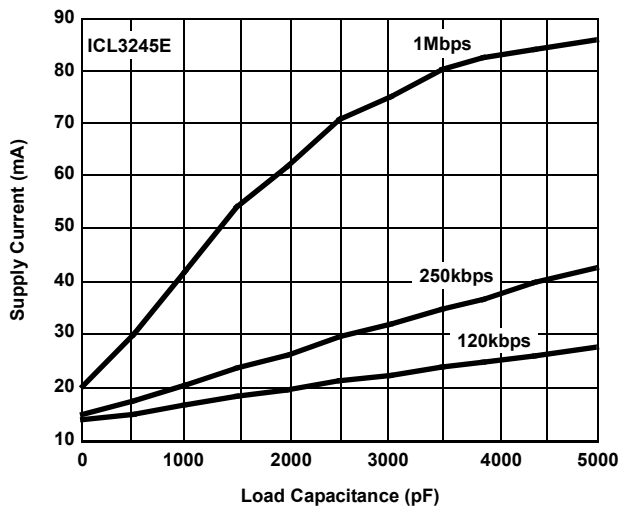

Figure 8. Supply Current vs Load Capacitance When Transmitting Data

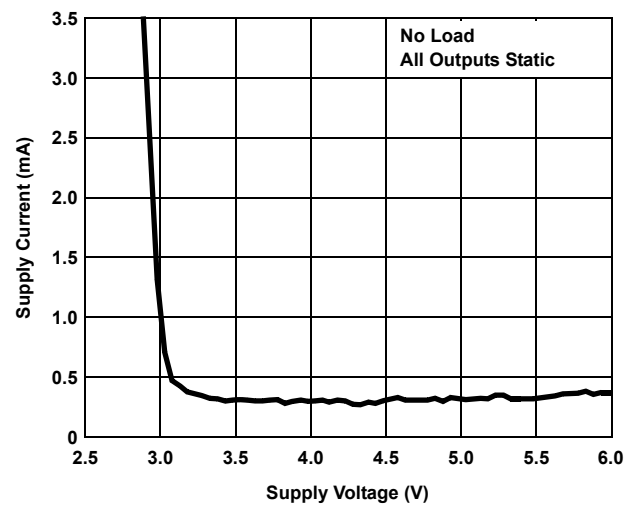

Figure 9. Supply Current vs Supply Voltage

4. Application Information

The ICL3225E, ICL3227E, and ICL3245E (ISL32xxE) operate from a single +3V to +5.5V supply, ensure a 1Mbps minimum data rate, require only four small external 0.1 μ F capacitors, feature low power consumption, and meet all EIA RS-232C and V.28 specifications.

4.1 Charge Pump

The ICL32xxE use regulated on-chip dual charge pumps as voltage doublers, and voltage inverters to generate ± 5.5 V transmitter supplies from a V_{CC} supply as low as 3.0V, which allows these devices to maintain RS-232 compliant output levels over the $\pm 10\%$ tolerance range of 3.3V powered systems. The efficient on-chip power supplies require only four small, external 0.1 μ F capacitors for the voltage doubler and inverter functions at $V_{CC} = 3.3$ V. See the [Capacitor Selection](#), and [Table 6 on page 19](#) for capacitor recommendations for other operating conditions. The charge pumps operate discontinuously (turning off when the V+ and V- supplies are pumped up to the nominal values), resulting in significant power savings.

4.1.1 Charge Pump Abs Max Ratings

These 3V to 5V RS-232 transceivers have been fully characterized for 3.0V to 3.6V operation and for critical points at 4.5V to 5.5V operation. Furthermore, load conditions were favorable using static logic states only.

The specified maximum values for V+ and V- are +7V and -7V, respectively. These limits apply for V_{CC} values set to 3.0V and 3.6V (see [Table 2](#)). For V_{CC} values set to 4.5V and 5.5V, the maximum values for V+ and V- can approach +9V and -7V, respectively ([Table 3 on page 13](#)). The breakdown characteristics for V+ and V- were measured with ± 13 V.

Table 2. V+ and V- Values for $V_{CC} = 3.0$ V to 3.6V

C ₁ (μ F)	C ₂ , C ₃ , C ₄ (μ F)	Load	T1IN (Logic State)	V+ (V)		V- (V)	
				V _{CC} = 3.0V	V _{CC} = 3.6V	V _{CC} = 3.0V	V _{CC} = 3.6V
0.1	0.1	Open	H	5.80	6.56	-5.60	-5.88
			L	5.80	6.56	-5.60	-5.88
			2.4kbps	5.80	6.56	-5.60	-5.88
		3k Ω // 1000pF	H	5.88	6.60	-5.56	-5.92
			L	5.76	6.36	-5.56	-5.76
			2.4kbps	6.00	6.64	-5.64	-5.96
0.047	0.33	Open	H	5.68	6.00	-5.60	-5.60
			L	5.68	6.00	-5.60	-5.60
			2.4kbps	5.68	6.00	-5.60	-5.60
		3k Ω // 1000pF	H	5.76	6.08	-5.64	-5.64
			L	5.68	6.04	-5.60	-5.60
			2.4kbps	5.84	6.16	-5.64	-5.72
1	1	Open	H	5.88	6.24	-5.60	-5.60
			L	5.88	6.28	-5.60	-5.64
			2.4kbps	5.80	6.20	-5.60	-5.60
		3k Ω // 1000pF	H	5.88	6.44	-5.64	-5.72
			L	5.88	6.04	-5.64	-5.64
			2.4kbps	5.92	6.40	-5.64	-5.64

Table 3. V+ and V- Values for $V_{CC} = 4.5V$ to $5.5V$

C ₁ (μF)	C ₂ , C ₃ , C ₄ (μF)	Load	T1IN (Logic State)	V+ (V)		V- (V)	
				V _{CC} = 4.5V	V _{CC} = 5.5V	V _{CC} = 4.5V	V _{CC} = 5.5V
0.1	0.1	Open	H	7.44	8.48	-6.16	-6.40
			L	7.44	8.48	-6.16	-6.44
			2.4kbps	7.44	8.48	-6.17	-6.44
		3kΩ // 1000pF	H	7.76	8.88	-6.36	-6.72
			L	7.08	8.00	-5.76	-5.76
			2.4kbps	7.76	8.84	-6.40	-6.64
0.047	0.33	Open	H	6.44	6.88	-5.80	-5.88
			L	6.48	6.88	-5.84	-5.88
			2.4kbps	6.44	6.88	-5.80	-5.88
		3kΩ // 1000pF	H	6.64	7.28	-5.92	-6.04
			L	6.24	6.60	-5.52	-5.52
			2.4kbps	6.72	7.16	-5.92	-5.96
1	1	Open	H	6.84	7.60	-5.76	-5.76
			L	6.88	7.60	-5.76	-5.76
			2.4kbps	6.92	7.56	-5.72	-5.76
		3kΩ // 1000pF	H	7.28	8.16	-5.80	-5.92
			L	6.44	6.84	-5.64	-6.84
			2.4kbps	7.08	7.76	-5.80	-5.80

The resulting new maximum voltages at V+ and V- are listed in [Table 4](#).

Table 4. New Measured Withstanding Voltages

V+, V- to Ground	±13V
V+ to V-	20V

4.2 Transmitters

The transmitters are proprietary, low dropout, inverting drivers that translate TTL/CMOS inputs to EIA/TIA-232 output levels. The transmitters are coupled with the on-chip ±5.5V supplies to deliver true RS-232 levels over a wide range of single supply system voltages.

Transmitter outputs disable and assume a high impedance state when the device enters the powerdown mode (see [Table 5 on page 15](#)). The outputs can be driven to ±12V when disabled.

All devices ensure a 1Mbps data rate for full load conditions (3kΩ and 250pF), $V_{CC} \geq 3.0V$, with one transmitter operating at full speed. Under more typical conditions of $V_{CC} \geq 3.3V$, $R_L = 3k\Omega$, and $C_L = 250pF$, one transmitter easily operates at 1.4Mbps. Transmitter skew is extremely low on these devices, and is specified at the receiver input trip points (1.4V), rather than the arbitrary 0V crossing point typical of other RS-232 families.

Transmitter inputs float if they remain unconnected and can increase I_{CC} . Connect unused inputs to GND for best performance.

4.3 Receivers

All the ICL32xxE devices contain standard inverting receivers, but only the ICL3245E receivers can tri-state using the FORCEOFF control line. The ICL3245E includes a noninverting (monitor) receiver (denoted by the R_{OUTB} label) that is always active regardless of the state of any control lines. Both receiver types convert RS-232 signals to CMOS output levels and accept inputs up to ±25V while presenting the required 3kΩ to 7kΩ input impedance (see Figure 10) even if the power is off (V_{CC} = 0V). The receivers' Schmitt trigger input stage uses hysteresis to increase noise immunity and decrease errors due to slow input signal transitions.

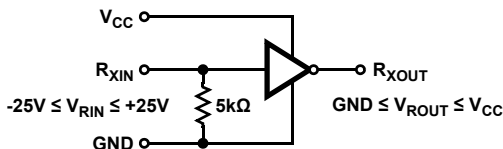

Figure 10. Inverting Receiver Connections

The ICL3245E inverting receivers disable during forced (manual) powerdown, but not during automatic powerdown (see Table 5). Conversely, the monitor receiver remains active even during manual powerdown, which makes it extremely useful for Ring Indicator monitoring. Standard receivers driving powered down peripherals must be disabled to prevent current flow through the peripheral's protection diodes (see Figures 11 and 12). When powered down, they cannot be used for wake-up functions, but the corresponding monitor receiver can be dedicated to this task as shown in Figure 12.

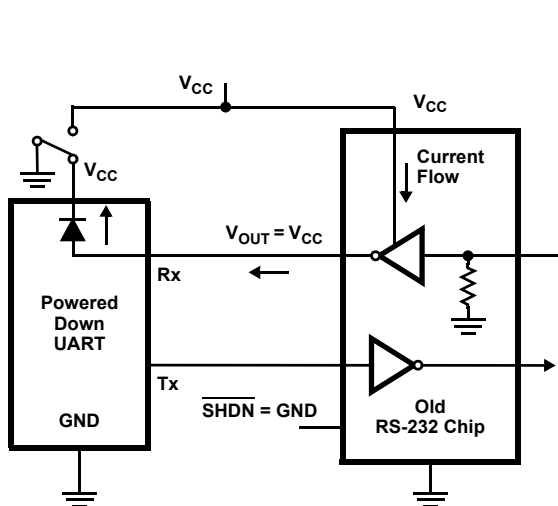

Figure 11. Power Drain Through Powered Down Peripheral

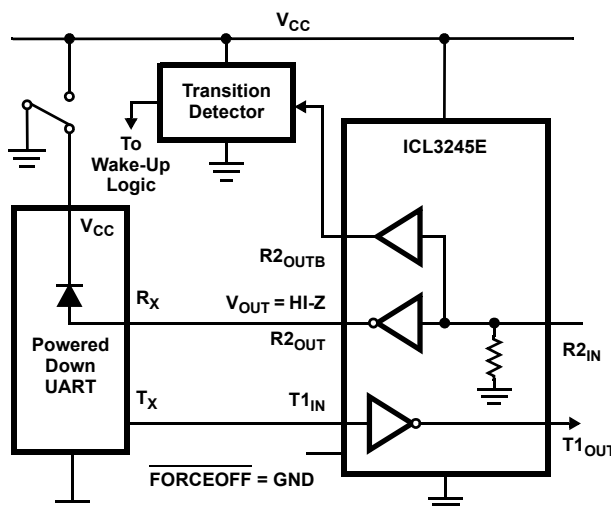

Figure 12. Disabled Receivers Prevent Power Drain

4.4 Powerdown Functionality

The 3V ICL32xxE devices require a nominal supply current of 0.3mA during normal operation (not in powerdown mode). This current is considerably less than the 5mA to 11mA current required of 5V RS-232 devices. The already low current requirement drops significantly when the device enters powerdown mode. In powerdown, supply current drops to 1µA, because the on-chip charge pump turns off (V+ collapses to V_{CC}, V- collapses to GND), and the transmitter outputs tri-state. Inverting receiver outputs may or may not disable in powerdown; see [Table 5](#) for details. This micro-power mode makes these devices ideal for battery powered and portable applications.

Table 5. Powerdown Logic Truth Table

RCVR or XMTR EDGE Within 30 Sec?	<u>FORCEOFF</u> Input	FORCEON Input	Transmitter Outputs	Receiver Outputs	R _{OUTB} Outputs (Note 7)	RS-232 Level Present at Receiver Input?	<u>INVALID</u> Output	Mode of Operation
ICL3225E, ICL3227E								
No	H	H	Active	Active	N.A.	No	L	Normal Operation (Enhanced Auto Powerdown Disabled)
No	H	H	Active	Active	N.A.	Yes	H	
Yes	H	L	Active	Active	N.A.	No	L	Normal Operation (Enhanced Auto Powerdown Enabled)
Yes	H	L	Active	Active	N.A.	Yes	H	
No	H	L	High-Z	Active	N.A.	No	L	Powerdown Due to Enhanced Auto Powerdown Logic
No	H	L	High-Z	Active	N.A.	Yes	H	
X	L	X	High-Z	Active	N.A.	No	L	Manual Powerdown
X	L	X	High-Z	Active	N.A.	Yes	H	
ICL322XE - <u>INVALID</u> Driving FORCEON and FORCEOFF (Emulates Automatic Powerdown)								
X	Note 8	Note 8	Active	Active	N.A.	Yes	H	Normal Operation
X	Note 8	Note 8	High-Z	Active	N.A.	No	L	Forced Auto Powerdown
ICL3245E								
No	H	H	Active	Active	Active	No	L	Normal Operation (Enhanced Auto Powerdown Disabled)
No	H	H	Active	Active	Active	Yes	H	
Yes	H	L	Active	Active	Active	No	L	Normal Operation (Enhanced Auto Powerdown Enabled)
Yes	H	L	Active	Active	Active	Yes	H	
No	H	L	High-Z	Active	Active	No	L	Powerdown Due to Enhanced Auto Powerdown Logic
No	H	L	High-Z	Active	Active	Yes	H	
X	L	X	High-Z	High-Z	Active	No	L	Manual Powerdown
X	L	X	High-Z	High-Z	Active	Yes	H	
ICL3245E - <u>INVALID</u> Driving FORCEON and FORCEOFF (Emulates Automatic Powerdown)								
X	Note 8	Note 8	Active	Active	Active	Yes	H	Normal Operation
X	Note 8	Note 8	High-Z	High-Z	Active	No	L	Forced Auto Powerdown

Notes:

7. Applies only to the ICL3245E.

8. Input is connected to INVALID Output.

4.4.1 Software Controlled (Manual) Powerdown

The ICL32xxE devices allow you to force the IC into the low power, standby state, and use a two pin approach where the FORCEON and FORCEOFF inputs determine the IC's mode. For always enabled operation, FORCEON and FORCEOFF are both strapped high. Under logic or software control, only the FORCEOFF input needs to be driven to switch between active and power-down modes. The FORCEON state is not critical because FORCEOFF overrides FORCEON. However, if strictly manual control over power-down is needed, you must strap FORCEON high to disable the automatic powerdown circuitry. The ICL3245E inverting (standard) receiver outputs also disable when the device is in powerdown, and eliminate the possible current path through a shutdown peripheral's input protection diode (see Figures 11 and 12).

Connecting FORCEOFF and FORCEON together disables the enhanced automatic powerdown feature, which enables them to function as a manual SHUTDOWN input (see Figure 13).

With any of the above control schemes, the time required to exit powerdown and resume transmission is only 100µs.

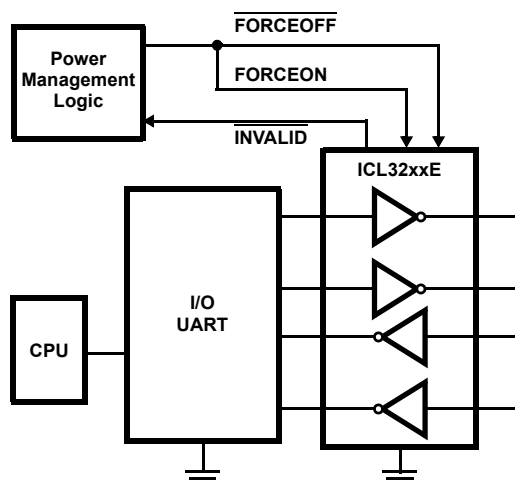

Figure 13. Connections for Manual Powerdown When No Valid Receiver Signals are Present

When using both manual and enhanced automatic powerdown (FORCEON = 0), the ICL32xxE devices do not power up from manual powerdown until both FORCEOFF and FORCEON are driven high, or until a transition occurs on a receiver or transmitter input. Figure 14 shows a circuit for ensuring that the ICL32xxE powers up as soon as FORCEOFF switches high. The rising edge of the master powerdown signal forces the device to power up, and the ICL32xxE returns to enhanced automatic powerdown mode an RC time constant after this rising edge. The time constant is not critical, because the ICL32xxE remains powered up for 30 seconds after the FORCEON falling edge, even if there are no signal transitions. The delay gives slow-to-wake systems (such as a mouse) plenty of time to start transmitting, and as long as it starts transmitting within 30 seconds both systems remain enabled.

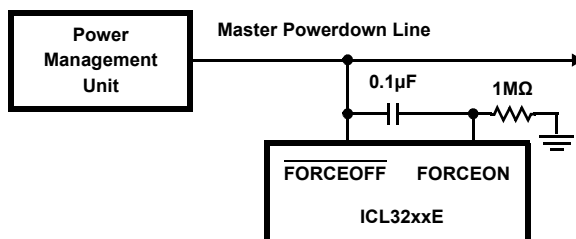

Figure 14. Circuit to Ensure Immediate Power Up When Exiting Forced Powerdown

4.4.2 INVALID Output

Table 5 on page 15 on the INVALID output always indicates whether 30µs have elapsed with invalid RS-232 signals (see Figures 15 and 17) persisting on all of the receiver inputs, and provides you a way to determine when

the interface block should power down. Invalid receiver levels occur whenever the driving peripheral's outputs are shut off (powered down) or when the RS-232 interface cable is disconnected. If an interface cable is disconnected and all the receiver inputs are floating (but pulled to GND by the internal receiver pull down resistors), the $\overline{\text{INVALID}}$ logic detects the invalid levels and drives the output low. The power management logic then uses this indicator to power down the interface block. Reconnecting the cable restores valid levels at the receiver inputs, $\overline{\text{INVALID}}$ switches high, and the power management logic wakes up the interface block. $\overline{\text{INVALID}}$ can also be used to indicate the DTR or RING INDICATOR signal, as long as the other receiver inputs are floating, or driven to GND (as in the case of a powered down driver).

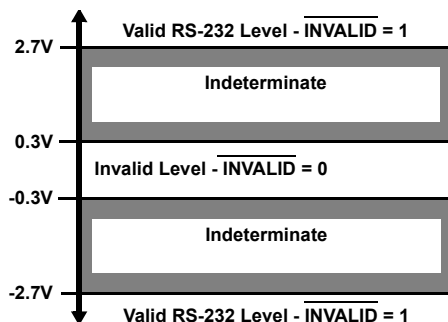

Figure 15. Definition of Valid RS-232 Receiver Levels

4.4.3 Enhanced Automatic Powerdown

Even greater power savings are available by using the ICL32xxE's enhanced automatic powerdown function. When the enhanced powerdown logic determines that no transitions have occurred on any of the transmitter or receiver inputs for 30 seconds, the charge pump and transmitters powerdown, and reduces supply current to 1μA. The ICL32xxE devices automatically power back up whenever they detect a transition on one of these inputs. The automatic powerdown feature provides additional system power savings without changes to the existing operating system.

Enhanced automatic powerdown operates when the FORCEON input is low and the $\overline{\text{FORCEOFF}}$ input is high. Tying FORCEON high disables automatic powerdown, but manual powerdown is always available using the overriding $\overline{\text{FORCEOFF}}$ input. [Table 5 on page 15](#) summarizes the enhanced automatic powerdown functionality.

[Figure 16](#) shows the enhanced powerdown control logic. **Note:** When the ICL32xxE enters powerdown (manually or automatically), the 30 second timer remains timed out (set), keeping the ICL32xxE powered down until FORCEON transitions high, or until a transition occurs on a receiver or transmitter input.

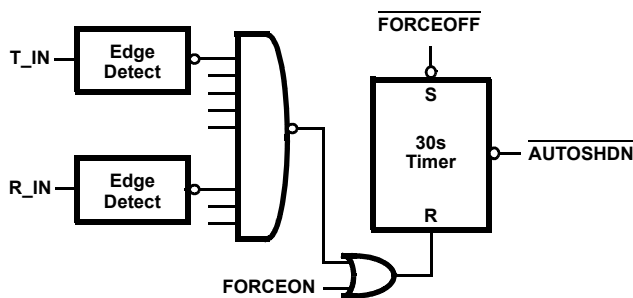

Figure 16. Enhanced Automatic Powerdown Logic

The $\overline{\text{INVALID}}$ output signal switches low to indicate that invalid levels have persisted on all of the receiver inputs for more than 30μs (see [Figure 17](#)), but this has no direct effect on the state of the ICL32xxE (see the next sections for methods of using $\overline{\text{INVALID}}$ to power down the device). $\overline{\text{INVALID}}$ switches high 1μs after detecting a valid RS-232 level on a receiver input. $\overline{\text{INVALID}}$ operates in all modes (forced or automatic powerdown, or forced on), so it is also useful for systems employing manual powerdown circuitry.

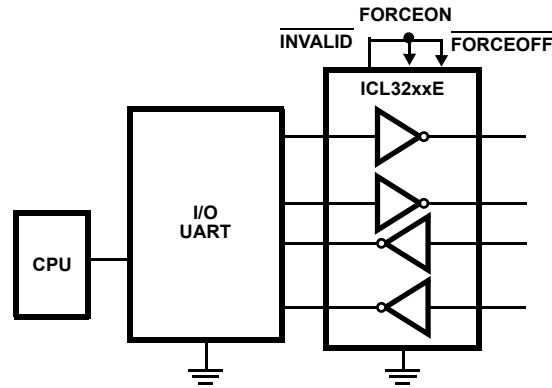

Figure 17. Connections for Automatic Powerdown When No Valid Receiver Signals are Present

The time to recover from automatic powerdown mode is typically 100µs.

4.4.4 Emulating Standard Automatic Powerdown

If enhanced automatic powerdown is not desired, you can implement the standard automatic powerdown feature (mimics the function on the ICL3221E/ICL3223E/ICL3243E) by connecting the INVALID output to the FORCEON and FORCEOFF inputs, as shown in [Figure 18](#). After 30µs of invalid receiver levels, INVALID switches low and drives the ICL32xxE into a forced powerdown condition. INVALID switches high as soon as a receiver input senses a valid RS-232 level, forcing the ICL32xxE to power on. See [“ICL322XE - INVALID Driving FORCEON and FORCEOFF \(Emulates Automatic Powerdown\)” on page 15](#) for an operational summary. This operational mode is perfect for handheld devices that communicate with another computer through a detachable cable. Detaching the cable allows the internal receiver pull-down resistors to pull the inputs to GND (an invalid RS-232 level), causing the 30µs timer to time out and drive the IC into powerdown. Reconnecting the cable restores valid levels and causes the IC to power back up.

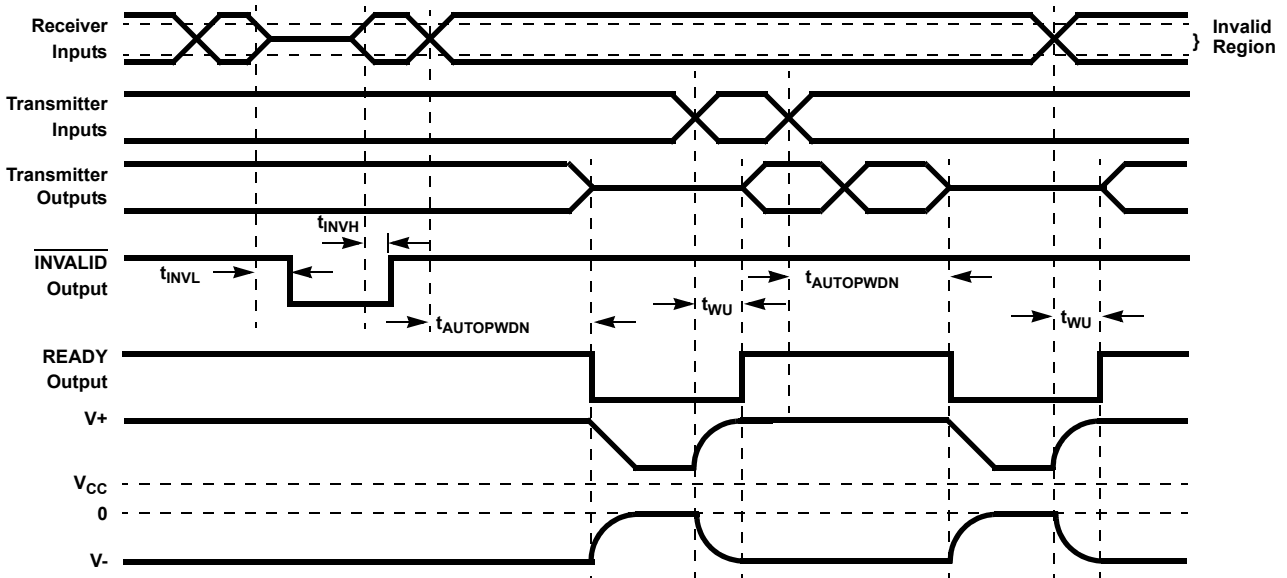

Figure 18. Enhanced Automatic Powerdown, INVALID and READY Timing Diagrams

4.4.5 Hybrid Automatic Powerdown Options

For devices that communicate only through a detachable cable, you can connect $\overline{\text{INVALID}}$ to $\overline{\text{FORCEOFF}}$ (with $\text{FORCEON} = 0$). While the cable is attached, $\overline{\text{INVALID}}$ and $\overline{\text{FORCEOFF}}$ remain high, so the enhanced automatic powerdown logic powers down the RS-232 device whenever there is 30 seconds of inactivity on the receiver and transmitter inputs. Detaching the cable allows the receiver inputs to drop to an invalid level (GND), so $\overline{\text{INVALID}}$ switches low and forces the RS-232 device to power down. The ICL32xxE remains powered down until the cable is reconnected ($\overline{\text{INVALID}} = \overline{\text{FORCEOFF}} = 1$), and a transition occurs on a receiver or transmitter input (see [Figure 16 on page 17](#)). For immediate power up when the cable is reattached, connect FORCEON to $\overline{\text{FORCEOFF}}$ through a network similar to that shown in [Figure 14 on page 16](#).

4.5 READY Output (ICL3225E and ICL3227E Only)

The READY output indicates that the ICL322xE is ready to transmit. READY switches low whenever the device enters powerdown, and switches back high during power-up when V_- reaches $-4V$ or lower.

4.6 Capacitor Selection

The charge pumps require $0.1\mu\text{F}$ capacitors for 3.3V operation. For other supply voltages see [Table 6](#) for capacitor values. Do not use values smaller than those listed in [Table 6](#). Increasing the capacitor values (by a factor of 2) reduces ripple on the transmitter outputs and slightly reduces power consumption. C_2 , C_3 , and C_4 can be increased without increasing C_1 's value, however, do not increase C_1 without also increasing C_2 , C_3 , and C_4 to maintain the proper ratios (C_1 to the other capacitors).

When using minimum required capacitor values, make sure that capacitor values do not degrade excessively with temperature. If in doubt, use capacitors with a larger nominal value. The capacitor's Equivalent Series Resistance (ESR) usually rises at low temperatures and it influences the amount of ripple on V_+ and V_- .

Table 6. Required Capacitor Values

V_{CC} (V)	C_1 (μF)	C_2, C_3, C_4 (μF)
3.0 to 3.6	0.1	0.1
4.5 to 5.5	0.047	0.33
3.0 to 5.5	0.1	0.47

4.7 Power Supply Decoupling

In most circumstances a $0.1\mu\text{F}$ bypass capacitor is adequate. In applications that are particularly sensitive to power supply noise, decouple V_{CC} to ground with a capacitor of the same value as the charge-pump capacitor C_1 . Connect the bypass capacitor as close as possible to the IC.

4.8 Operation Down to 2.7V

The ICL32xxE transmitter outputs meet RS-562 levels ($\pm 3.7V$), at full data rate, with V_{CC} as low as 2.7V. RS-562 levels typically ensure interoperability with RS-232 devices.

4.9 Transmitter Outputs when Exiting Powerdown

[Figure 19 on page 20](#) shows the response of two transmitter outputs when exiting powerdown mode. As they activate, the two transmitter outputs properly go to opposite RS-232 levels, with no glitching, ringing, or undesirable transients. Each transmitter is loaded with $3k\Omega$ in parallel with 2500pF . **Note:** The transmitters enable only when the magnitude of the supplies exceed approximately 3V.

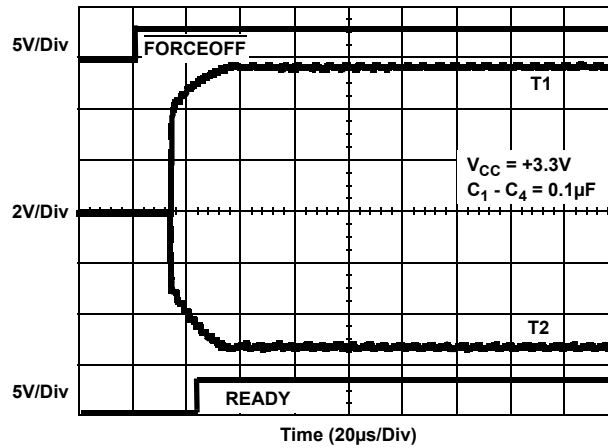

Figure 19. Transmitter Outputs When Exiting Powerdown

4.10 Mouse Driveability

The ICL3245E is specifically designed to power a serial mouse while operating from low voltage supplies. [Figure 20](#) shows the transmitter output voltages under increasing load current. The on-chip switching regulator ensures the transmitters supply at least $\pm 5V$ during worst case conditions (15mA for paralleled V+ transmitters, 7.3mA for single V- transmitter).

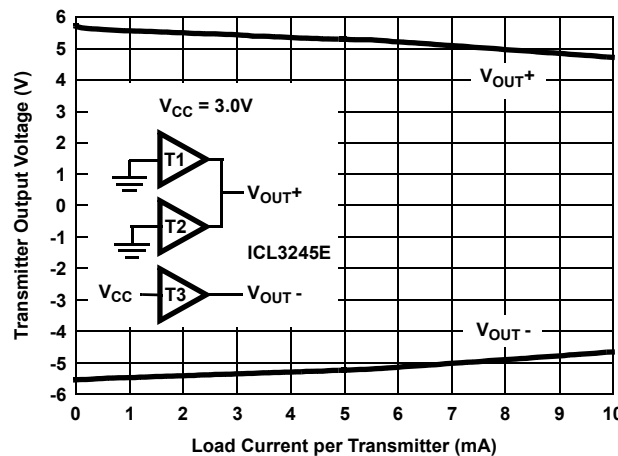

Figure 20. Transmitter Output Voltage vs Load Current
(per Transmitter, For Example, Double Current Axis for Total V_{OUT+} Current)

4.11 High Data Rates

The ICL32xxE maintain the RS-232 $\pm 5V$ minimum transmitter output voltages even at high data rates. [Figure 21 on page 21](#) shows a transmitter loopback test circuit, and [Figure 22 on page 21](#) shows the loopback test result at 250kbps. For this test, all transmitters were simultaneously driving RS-232 loads in parallel with 1000pF, at 250kbps. [Figure 23 on page 21](#) shows the loopback results for a single transmitter driving 250pF and an RS-232 load at 1Mbps. The static transmitters were also loaded with an RS-232 receiver.

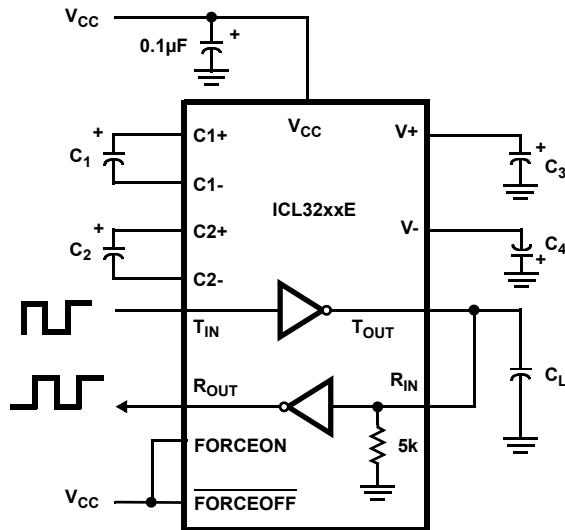

Figure 21. Transmitter Loopback Test Circuit

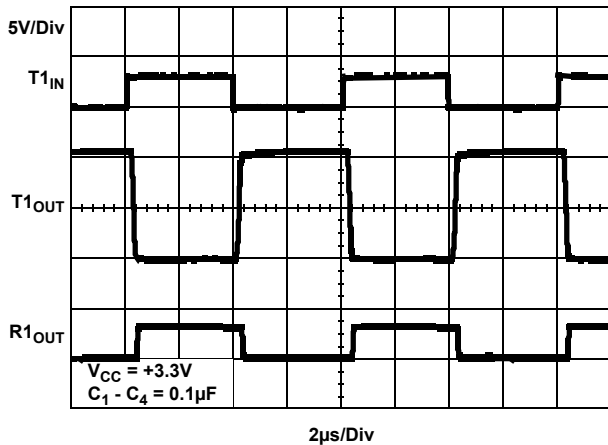

Figure 22. Loopback Test at 250kbps ($C_L = 1000\text{pF}$)

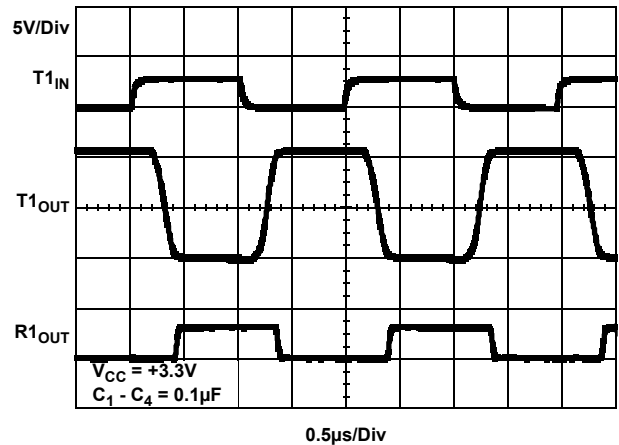

Figure 23. Loopback Test at 1Mbps ($C_L = 250\text{pF}$)

4.12 Interconnection with 3V and 5V Logic

The ICL32xxE directly interfaces with 5V CMOS and TTL logic families. The AC, HC, and CD4000 outputs can drive the ICL32xxE inputs with the ICL32xxE at 3.3V and the logic supply at 5V, but ICL32xxE outputs do not reach the minimum V_{IH} for these logic families. See [Table 7](#) for more information.

Table 7. Logic Family Compatibility with Various Supply Voltages

System Power-Supply Voltage (V)	V_{CC} Supply Voltage (V)	Compatibility
3.3	3.3	Compatible with all CMOS families.
5	5	Compatible with all TTL and CMOS logic families.
5	3.3	Compatible with ACT and HCT CMOS, and with TTL. ICL32xxE outputs are incompatible with AC, HC, and CD4000 CMOS inputs.

5. ±15kV ESD Protection

All pins on the ICL32xxE devices include ESD protection structures, but the ICL32xxE family incorporates advanced structures that allow the RS-232 pins (transmitter outputs and receiver inputs) to survive ESD events up to ±15kV. The RS-232 pins are particularly vulnerable to ESD damage because they typically connect to an exposed port on the exterior of the finished product. Touching the port pins, or connecting a cable, can cause an ESD event that might destroy unprotected ICs. The ESD structures protect the device whether or not it is powered up, protect without allowing any latchup mechanism to activate, and do not interfere with RS-232 signals as large as ±25V.

5.1 Human Body Model (HBM) Testing

The Human Body Model (HBM) test method emulates the ESD event delivered to an IC during human handling. The tester delivers the charge through a 1.5kΩ current limiting resistor, so the test is less severe than the IEC61000 test, which uses a 330Ω limiting resistor. The HBM method determines an IC's ability to withstand the ESD transients typically present during handling and manufacturing. Due to the random nature of these events, each pin is tested with respect to all other pins. The RS-232 pins on "E" family devices can withstand HBM ESD events to ±15kV.

5.2 IEC61000-4-2 Testing

The IEC61000 test method applies to finished equipment, rather than to an individual IC. Therefore, the pins most likely to suffer an ESD event are those that are exposed to the outside world (the RS-232 pins in this case), and the IC is tested in its typical application configuration (power applied) rather than testing each pin-to-pin combination. The lower current limiting resistor coupled with the larger charge storage capacitor yields a test that is much more severe than the HBM test. The extra ESD protection built into this device's RS-232 pins allows the design of equipment meeting Level 4 criteria without the need for additional board level protection on the RS-232 port.

5.3 Air-Gap Discharge Test Method

For the air-gap discharge test method, a charged probe tip moves toward the IC pin until the voltage arcs to it. The current waveform delivered to the IC pin depends on factors such as approach speed, humidity, and temperature, so it is difficult to obtain repeatable results. The "E" device RS-232 pins withstand ±15kV air-gap discharges.

5.4 Contact Discharge Test Method

During the contact discharge test, the probe contacts the tested pin before the probe tip is energized, and eliminates the variables associated with the air-gap discharge. The result is a more repeatable and predictable test, but equipment limits prevent testing devices at voltages higher than ±8kV. All "E" family devices survive ±8kV contact discharges on the RS-232 pins.

6. Die Characteristics

Substrate Potential (Powered Up)	GND
Transistor Count	ISL3225E: 937 ISL3227E: 825 ISL3245E: 1109
Process	Si Gate CMOS

7. Revision History

Rev.	Date	Description
13	May.2.19	Updated to latest formatting. Updated Ordering information table by adding active tape and reel information, updated notes, and removed retired parts Added "Charge Pump Abs Max Ratings" on page 12. Removed About Intersil section. Removed PDIP, TSSOP, and SOIC information throughout document. Updated disclaimer.
12	Dec.12.15	Updated entire datasheet applying Intersil's new standards. Updated Ordering information table on page 2. -Updated Tape and Reel note. -Updated Note 2. -Added MSL note. -Removed all non-compliant products. In the "Electrical Specifications" table under "ESD Performance" on page 9, Updated All Other pins section by changing typical value for the ICL3245E from "±3" to "±2" and adding ICL3225E and ICL3227E information.
11	Dec.3.15	Updated Ordering Information Table on page 2: Added replacement part numbers for ICL3245ECBZ and ICL3245ECVZ.
10	Aug.31.15	Ordering Information Table on page 2. Added Revision History. Added About Intersil Verbiage. Updated POD M28.3 to latest revision changes: Added land pattern.

8. Package Outline Drawings

For the most recent package outline drawing, see [M16.209](#).

M16.209 (JEDEC MO-150-AC ISSUE B)
16 Lead Shrink Small Outline Plastic Package (SSOP)

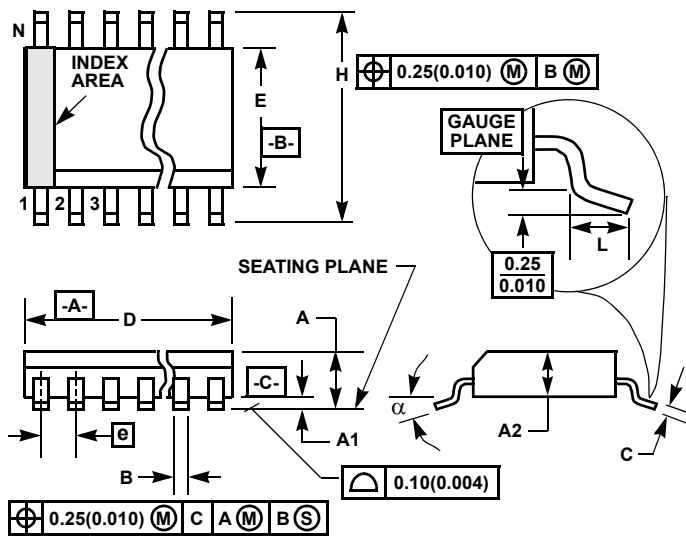

SYMBOL	INCHES		MILLIMETERS		NOTES
	MIN	MAX	MIN	MAX	
A	-	0.078	-	2.00	-
A1	0.002	-	0.05	-	-
A2	0.065	0.072	1.65	1.85	-
B	0.009	0.014	0.22	0.38	9
C	0.004	0.009	0.09	0.25	-
D	0.233	0.255	5.90	6.50	3
E	0.197	0.220	5.00	5.60	4
e	0.026 BSC		0.65 BSC		-
H	0.292	0.322	7.40	8.20	-
L	0.022	0.037	0.55	0.95	6
N	16		16		7
a	0°	8°	0°	8°	-

Rev. 3 6/05

Notes:

1. Symbols are defined in the "MO Series Symbol List" in Section 2.2 of Publication Number 95.
2. Dimensioning and tolerancing per ANSI Y14.5M-1982.
3. Dimension "D" does not include mold flash, protrusions or gate burrs. Mold flash, protrusion and gate burrs shall not exceed 0.20mm (0.0078 inch) per side.
4. Dimension "E" does not include interlead flash or protrusions. Interlead flash and protrusions shall not exceed 0.20mm (0.0078 inch) per side.
5. The chamfer on the body is optional. If it is not present, a visual index feature must be located within the crosshatched area.
6. "L" is the length of terminal for soldering to a substrate.
7. "N" is the number of terminal positions.
8. Terminal numbers are shown for reference only.
9. Dimension "B" does not include dambar protrusion. Allowable dambar protrusion shall be 0.13mm (0.005 inch) total in excess of "B" dimension at maximum material condition.
10. Controlling dimension: MILLIMETER. Converted inch dimensions are not necessarily exact.

For the most recent package outline drawing, see [M20.209](#).

M20.209 (JEDEC MO-150-AE ISSUE B)
20 Lead Shrink Small Outline Plastic Package (SSOP)

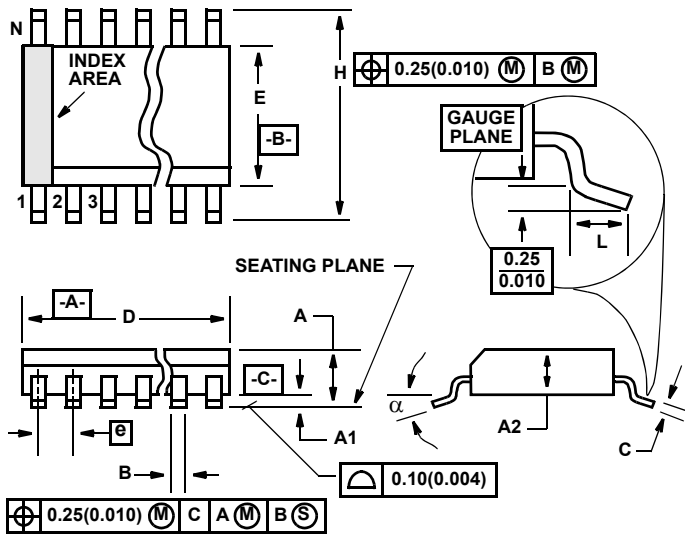

SYMBOL	INCHES		MILLIMETERS		NOTES
	MIN	MAX	MIN	MAX	
A	0.068	0.078	1.73	1.99	
A1	0.002	0.008'	0.05	0.21	
A2	0.066	0.070'	1.68	1.78	
B	0.010'	0.015	0.25	0.38	9
C	0.004	0.008	0.09	0.20'	
D	0.278	0.289	7.07	7.33	3
E	0.205	0.212	5.20'	5.38	4
e	0.026 BSC		0.65 BSC		
H	0.301	0.311	7.65	7.90'	
L	0.025	0.037	0.63	0.95	6
N	20		20		7
a	0 deg.	8 deg.	0 deg.	8 deg.	

Rev. 3 11/02

Notes:

1. Symbols are defined in the "MO Series Symbol List" in Section 2.2 of Publication Number 95.
2. Dimensioning and tolerancing per ANSI Y14.5M-1982.
3. Dimension "D" does not include mold flash, protrusions or gate burrs. Mold flash, protrusion and gate burrs shall not exceed 0.20mm (0.0078 inch) per side.
4. Dimension "E" does not include interlead flash or protrusions. Interlead flash and protrusions shall not exceed 0.20mm (0.0078 inch) per side.
5. The chamfer on the body is optional. If it is not present, a visual index feature must be located within the crosshatched area.
6. "L" is the length of terminal for soldering to a substrate.
7. "N" is the number of terminal positions.
8. Terminal numbers are shown for reference only.
9. Dimension "B" does not include dambar protrusion. Allowable dambar protrusion shall be 0.13mm (0.005 inch) total in excess of "B" dimension at maximum material condition.
10. Controlling dimension: MILLIMETER. Converted inch dimensions are not necessarily exact.

For the most recent package outline drawing, see [M28.209](#).

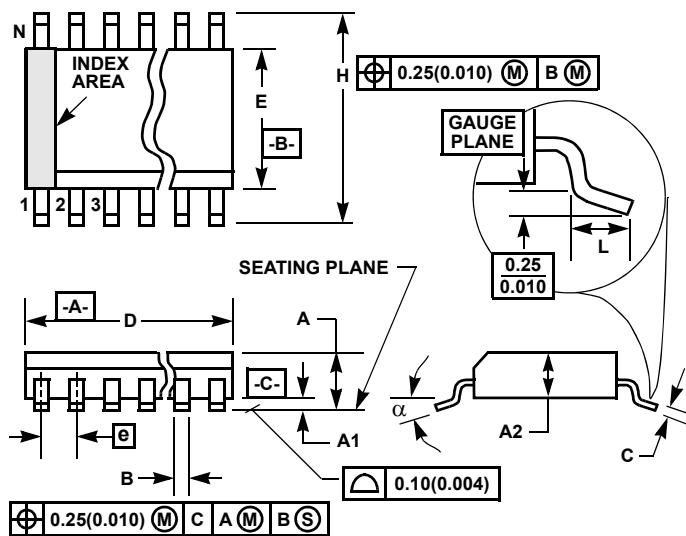

M28.209 (JEDEC MO-150-AH ISSUE B)
28 Lead Shrink Small Outline Plastic Package (SSOP)

SYMBOL	INCHES		MILLIMETERS		NOTES
	MIN	MAX	MIN	MAX	
A	-	0.078	-	2.00	-
A1	0.002	-	0.05	-	-
A2	0.065	0.072	1.65	1.85	-
B	0.009	0.014	0.22	0.38	9
C	0.004	0.009	0.09	0.25	-
D	0.390	0.413	9.90	10.50	3
E	0.197	0.220	5.00	5.60	4
e	0.026 BSC		0.65 BSC		-
H	0.292	0.322	7.40	8.20	-
L	0.022	0.037	0.55	0.95	6
N	28		28		7
α	0°	8°	0°	8°	-

Notes:

1. Symbols are defined in the "MO Series Symbol List" in Section 2.2 of Publication Number 95.
2. Dimensioning and tolerancing per ANSI Y14.5M-1982.
3. Dimension "D" does not include mold flash, protrusions or gate burrs. Mold flash, protrusion and gate burrs shall not exceed 0.20mm (0.0078 inch) per side.
4. Dimension "E" does not include interlead flash or protrusions. Interlead flash and protrusions shall not exceed 0.20mm (0.0078 inch) per side.
5. The chamfer on the body is optional. If it is not present, a visual index feature must be located within the crosshatched area.
6. "L" is the length of terminal for soldering to a substrate.
7. "N" is the number of terminal positions.
8. Terminal numbers are shown for reference only.
9. Dimension "B" does not include dambar protrusion. Allowable dambar protrusion shall be 0.13mm (0.005 inch) total in excess of "B" dimension at maximum material condition.
10. Controlling dimension: MILLIMETER. Converted inch dimensions are not necessarily exact.

Rev. 2 6/05

Notice

1. Descriptions of circuits, software and other related information in this document are provided only to illustrate the operation of semiconductor products and application examples. You are fully responsible for the incorporation or any other use of the circuits, software, and information in the design of your product or system. Renesas Electronics disclaims any and all liability for any losses and damages incurred by you or third parties arising from the use of these circuits, software, or information.
2. Renesas Electronics hereby expressly disclaims any warranties against and liability for infringement or any other claims involving patents, copyrights, or other intellectual property rights of third parties, by or arising from the use of Renesas Electronics products or technical information described in this document, including but not limited to, the product data, drawings, charts, programs, algorithms, and application examples.
3. No license, express, implied or otherwise, is granted hereby under any patents, copyrights or other intellectual property rights of Renesas Electronics or others.
4. You shall not alter, modify, copy, or reverse engineer any Renesas Electronics product, whether in whole or in part. Renesas Electronics disclaims any and all liability for any losses or damages incurred by you or third parties arising from such alteration, modification, copying or reverse engineering.
5. Renesas Electronics products are classified according to the following two quality grades: "Standard" and "High Quality". The intended applications for each Renesas Electronics product depends on the product's quality grade, as indicated below.
 - "Standard": Computers; office equipment; communications equipment; test and measurement equipment; audio and visual equipment; home electronic appliances; machine tools; personal electronic equipment; industrial robots; etc.
 - "High Quality": Transportation equipment (automobiles, trains, ships, etc.); traffic control (traffic lights); large-scale communication equipment; key financial terminal systems; safety control equipment; etc.Unless expressly designated as a high reliability product or a product for harsh environments in a Renesas Electronics data sheet or other Renesas Electronics document, Renesas Electronics products are not intended or authorized for use in products or systems that may pose a direct threat to human life or bodily injury (artificial life support devices or systems; surgical implantations; etc.), or may cause serious property damage (space system; undersea repeaters; nuclear power control systems; aircraft control systems; key plant systems; military equipment; etc.). Renesas Electronics disclaims any and all liability for any damages or losses incurred by you or any third parties arising from the use of any Renesas Electronics product that is inconsistent with any Renesas Electronics data sheet, user's manual or other Renesas Electronics document.
6. When using Renesas Electronics products, refer to the latest product information (data sheets, user's manuals, application notes, "General Notes for Handling and Using Semiconductor Devices" in the reliability handbook, etc.), and ensure that usage conditions are within the ranges specified by Renesas Electronics with respect to maximum ratings, operating power supply voltage range, heat dissipation characteristics, installation, etc. Renesas Electronics disclaims any and all liability for any malfunctions, failure or accident arising out of the use of Renesas Electronics products outside of such specified ranges.
7. Although Renesas Electronics endeavors to improve the quality and reliability of Renesas Electronics products, semiconductor products have specific characteristics, such as the occurrence of failure at a certain rate and malfunctions under certain use conditions. Unless designated as a high reliability product or a product for harsh environments in a Renesas Electronics data sheet or other Renesas Electronics document, Renesas Electronics products are not subject to radiation resistance design. You are responsible for implementing safety measures to guard against the possibility of bodily injury, injury or damage caused by fire, and/or danger to the public in the event of a failure or malfunction of Renesas Electronics products, such as safety design for hardware and software, including but not limited to redundancy, fire control and malfunction prevention, appropriate treatment for aging degradation or any other appropriate measures. Because the evaluation of microcomputer software alone is very difficult and impractical, you are responsible for evaluating the safety of the final products or systems manufactured by you.
8. Please contact a Renesas Electronics sales office for details as to environmental matters such as the environmental compatibility of each Renesas Electronics product. You are responsible for carefully and sufficiently investigating applicable laws and regulations that regulate the inclusion or use of controlled substances, including without limitation, the EU RoHS Directive, and using Renesas Electronics products in compliance with all these applicable laws and regulations. Renesas Electronics disclaims any and all liability for damages or losses occurring as a result of your noncompliance with applicable laws and regulations.
9. Renesas Electronics products and technologies shall not be used for or incorporated into any products or systems whose manufacture, use, or sale is prohibited under any applicable domestic or foreign laws or regulations. You shall comply with any applicable export control laws and regulations promulgated and administered by the governments of any countries asserting jurisdiction over the parties or transactions.
10. It is the responsibility of the buyer or distributor of Renesas Electronics products, or any other party who distributes, disposes of, or otherwise sells or transfers the product to a third party, to notify such third party in advance of the contents and conditions set forth in this document.
11. This document shall not be reprinted, reproduced or duplicated in any form, in whole or in part, without prior written consent of Renesas Electronics.
12. Please contact a Renesas Electronics sales office if you have any questions regarding the information contained in this document or Renesas Electronics products.

(Note1) "Renesas Electronics" as used in this document means Renesas Electronics Corporation and also includes its directly or indirectly controlled subsidiaries.

(Note2) "Renesas Electronics product(s)" means any product developed or manufactured by or for Renesas Electronics.

(Rev.4.0-1 November 2017)

Corporate Headquarters

TOYOSU FORESIA, 3-2-24 Toyosu,
Koto-ku, Tokyo 135-0061, Japan
www.renesas.com

Contact Information

For further information on a product, technology, the most up-to-date version of a document, or your nearest sales office, please visit:
www.renesas.com/contact/

Trademarks

Renesas and the Renesas logo are trademarks of Renesas Electronics Corporation. All trademarks and registered trademarks are the property of their respective owners.



Looking for pricing, stock, or lifecycle information?

Click below to explore more details on WIN SOURCE:

 [View ICL3245ECAZ-T on WIN SOURCE](#)

 [Intersil Information](#)

Optimize Your Supply Chain with WIN SOURCE Solutions

-  Global Sourcing Solution
-  Obsolete Management
-  Cost Control Management
-  Shortage Management
-  Alternative Solution
-  Excess Inventory Management