



# THE DATASHEET OF ICL232MJE



ICL232

+5V Powered, Dual RS-232 Transmitter/Receiver

FN3020  
Rev 8.00  
October 15, 2014

The ICL232 is a dual RS-232 transmitter/receiver interface circuit that meets all EIA RS-232C and V.28 specifications. It requires a single +5V power supply, and features two onboard charge pump voltage converters which generate +10V and -10V supplies from the 5V supply.

The drivers feature true TTL/CMOS input compatibility, slew-rate-limited output, and 300Ω power-off source impedance. The receivers can handle up to +30V, and have a 3kΩ to 7kΩ input impedance. The receivers also have hysteresis to improve noise rejection.

**Applications**

- Any system requiring RS-232 communications port
  - Computer - portable and mainframe
  - Peripheral - printers and terminals
  - Portable instrumentation
  - Modems
- Dataloggers

**Features**

- Meets all RS-232C and V.28 specifications
- Requires only single +5V power supply
- Onboard voltage doubler/inverter
- Low power consumption
- 2 drivers
  - ±9V output swing for +5V Input
  - 300Ω power-off source impedance
  - Output current limiting
  - TTL/CMOS compatible
  - 30V/μs maximum slew rate
- 2 Receivers
  - ±30V input voltage range
  - 3kΩ to 7kΩ input impedance
  - 0.5V hysteresis to improve noise rejection
- All critical parameters are guaranteed over the entire commercial, industrial and military temperature ranges
- Pb-free (RoHS compliant)

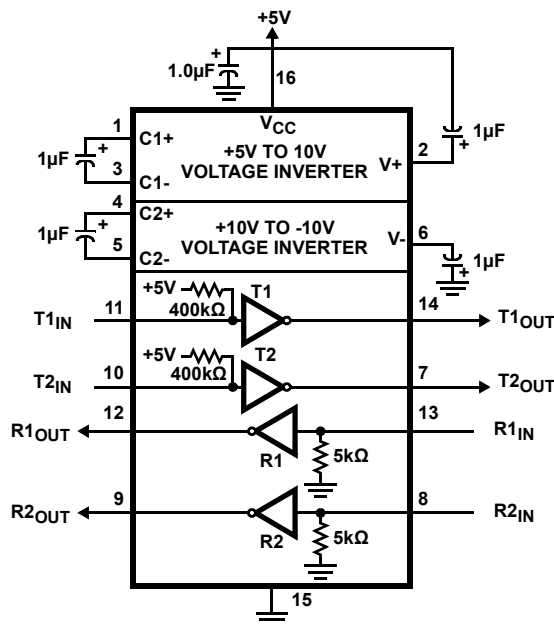
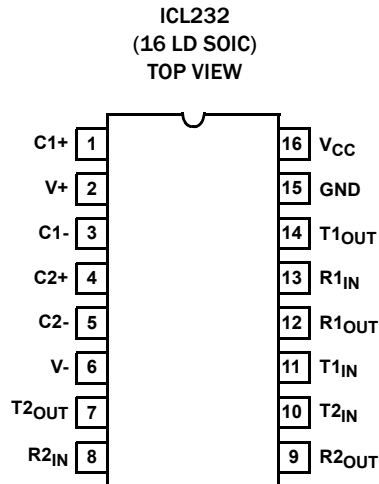

FIGURE 1. FUNCTIONAL DIAGRAM

## Pin Configuration



## Pin Descriptions

PIN #	PIN NAME	DESCRIPTION
1	C1+	External capacitor "+" for internal voltage doubler.
2	V+	Internally generated +10V (typical) supply.
3	C1-	External capacitor "-" for internal voltage doubler.
4	C2+	External capacitor "+" internal voltage inverter.
5	C2-	External capacitor "-" internal voltage inverter.
6	V-	Internally generated -10V (typical) supply.
7	T2 <sub>OUT</sub>	RS-232 Transmitter 2 output $\pm 10V$ (typical).
8	R2 <sub>IN</sub>	RS-232 Receiver 2 input, with internal 5k pulldown resistor to GND.
9	R2 <sub>OUT</sub>	Receiver 2 TTL/CMOS output.
10	T2 <sub>IN</sub>	Transmitter 2 TTL/CMOS input, with internal 400k pullup resistor to V <sub>CC</sub> .
11	T1 <sub>IN</sub>	Transmitter 1 TTL/CMOS input, with internal 400k pullup resistor to V <sub>CC</sub> .
12	R1 <sub>OUT</sub>	Receiver 1 TTL/CMOS output.
13	R1 <sub>IN</sub>	RS-232 Receiver 1 input, with internal 5k pulldown resistor to GND.
14	T1 <sub>OUT</sub>	RS-232 Transmitter 1 output $\pm 10V$ (typical).
15	GND	Supply Ground
16	V <sub>CC</sub>	Positive Power Supply +5V $\pm 10\%$ .

## Ordering Information

PART NUMBER (Notes 1, 2)	TEMP RANGE (°C)	PACKAGE (Pb-Free)	PKG DWG. #
ICL232CBEZ	0 to +70	16 Ld SOIC	M16.3
ICL232CBEZT (Note 3)	0 to +70	16 Ld SOIC	M16.3

### NOTES:

- These Intersil Pb-free plastic packaged products employ special Pb-free material sets, molding compounds/die attach materials, and 100% matte tin plate plus anneal (e3 termination finish, which is RoHS compliant and compatible with both SnPb and Pb-free soldering operations). Intersil Pb-free products are MSL classified at Pb-free peak reflow temperatures that meet or exceed the Pb-free requirements of IPC/JEDEC J STD-020.
- For Moisture Sensitivity Level (MSL), please see product information page for [ICL232](#). For more information on MSL, please see tech brief [TB363](#).
- Please refer to [TB347](#) for details on reel specifications.

## Absolute Maximum Ratings

V <sub>CC</sub> to Ground	.....(GND -0.3V) < V <sub>CC</sub> < 6V
V+ to Ground	..... (V <sub>CC</sub> -0.3V) < V+ < 12V
V- to Ground	.....-12V < V- < (GND +0.3V)
Input Voltages	
T <sub>1IN</sub> , T <sub>2IN</sub>	.....(V- -0.3V) < V <sub>IN</sub> < (V+ +0.3V)
R <sub>1IN</sub> , R <sub>2IN</sub>	..... ±30V
Output Voltages	
T <sub>1OUT</sub> , T <sub>2OUT</sub>	..... (V- -0.3V) < V <sub>TXOUT</sub> < (V+ +0.3V)
R <sub>1OUT</sub> , R <sub>2OUT</sub>	.....(GND -0.3V) < V <sub>RXOUT</sub> < (V <sub>CC</sub> +0.3V)
Short Circuit Duration	
T <sub>1OUT</sub> , T <sub>2OUT</sub>	..... Continuous
R <sub>1OUT</sub> , R <sub>2OUT</sub>	..... Continuous

## Operating Conditions

Temperature Ranges	
ICL232C	..... 0 °C to +70 °C

CAUTION: Do not operate at or near the maximum ratings listed for extended periods of time. Exposure to such conditions may adversely impact product reliability and result in failures not covered by warranty.

### NOTE:

4.  $\theta_{JA}$  is measured with the component mounted on an evaluation PC board in free air.

## Thermal Information

Thermal Resistance (Typical)	$\theta_{JA}$ (°C/W)	$\theta_{JC}$ (°C/W)
SOIC Package (Note 4)	100	N/A
Maximum Junction Temperature		
Plastic Packages	.....+150 °C	
Maximum Storage Temperature Range	.....-65 °C to +150 °C	
Maximum Lead Temperature (Soldering 10s)	.....+300 °C	
Pb-Free Reflow Profile	..... see <a href="#">TB493</a>	

**Electrical Specifications** Test Conditions: V<sub>CC</sub> = +5V ±10%, T<sub>A</sub> = Operating Temperature Range. Test Circuit as in [Figure 2](#). Unless otherwise specified.

PARAMETER	TEST CONDITIONS	MIN	TYP	MAX	UNITS
Transmitter Output Voltage Swing, T <sub>OUT</sub>	T <sub>1OUT</sub> and T <sub>2OUT</sub> Loaded with 3kΩ to Ground	±5	±9	±10	V
Power Supply Current, I <sub>CC</sub>	Outputs Unloaded, T <sub>A</sub> = +25 °C	-	5	10	mA
T <sub>IN</sub> , Input Logic Low, V <sub>IL</sub>		-	-	0.8	V
T <sub>IN</sub> , Input Logic High, V <sub>IH</sub>		2.0	-	-	V
Logic Pullup Current, I <sub>p</sub>	T <sub>1IN</sub> , T <sub>2IN</sub> = 0V	-	15	200	μA
RS-232 Input Voltage Range, V <sub>IN</sub>		-30	-	+30	V
Receiver Input Impedance, R <sub>IN</sub>	V <sub>IN</sub> = ±3V	3.0	5.0	7.0	kΩ
Receiver Input Low Threshold, V <sub>IN</sub> (H-L)	V <sub>CC</sub> = 5V, T <sub>A</sub> = +25 °C	0.8	1.2	-	V
Receiver Input High Threshold, V <sub>IN</sub> (L-H)	V <sub>CC</sub> = 5V, T <sub>A</sub> = +25 °C	-	1.7	2.4	V
Receiver Input Hysteresis, V <sub>HYST</sub>		0.2	0.5	1.0	V
TTL/CMOS Receiver Output Voltage Low, V <sub>OL</sub>	I <sub>OUT</sub> = 3.2mA	-	0.1	0.4	V
TTL/CMOS Receiver Output Voltage High, V <sub>OH</sub>	I <sub>OUT</sub> = -1.0mA	3.5	4.6	-	V
Propagation Delay, t <sub>PD</sub>	RS-232 to TTL	-	0.5	-	μs
Instantaneous Slew Rate, SR	C <sub>L</sub> = 10pF, R <sub>L</sub> = 3kΩ, T <sub>A</sub> = +25 °C (Notes 5, 6)	-	-	30	V/μs
Transition Region Slew Rate, SR <sub>T</sub>	R <sub>L</sub> = 3kΩ, C <sub>L</sub> = 2500pF Measured from +3V to -3V or -3V to +3V	-	3	-	V/μs
Output Resistance, R <sub>OUT</sub>	V <sub>CC</sub> = V+ = V- = 0V, V <sub>OUT</sub> = ±2V	300	-	-	Ω
RS-232 Output Short Circuit Current, I <sub>SC</sub>	T <sub>1OUT</sub> or T <sub>2OUT</sub> Shorted to GND	-	±10	-	mA

### NOTES:

5. Limit is not production tested. The maximum was established via characterization and/or design simulations.
6. See [Figure 7](#) for definition.

## Test Circuits

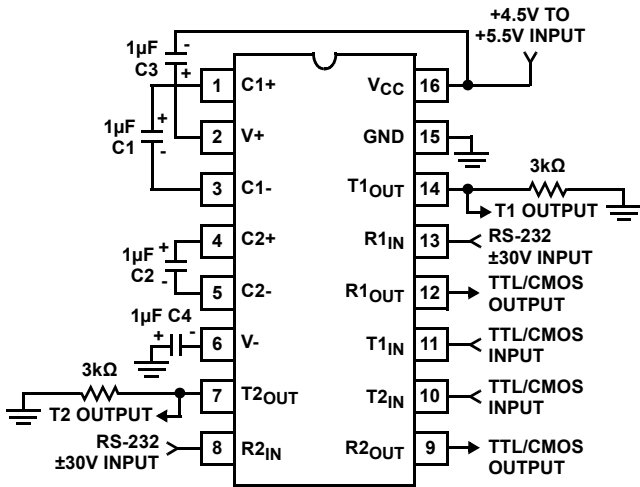

FIGURE 2. GENERAL TEST CIRCUIT

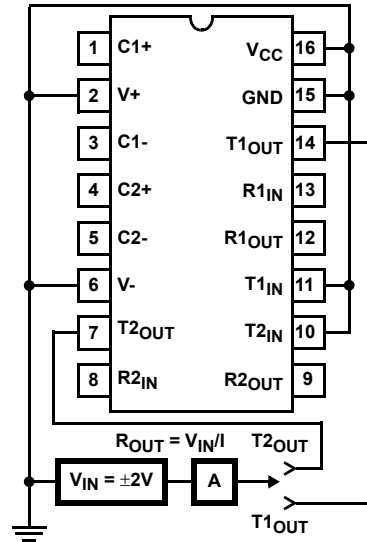

FIGURE 3. POWER-OFF SOURCE RESISTANCE CONFIGURATION

## Typical Performance Curves

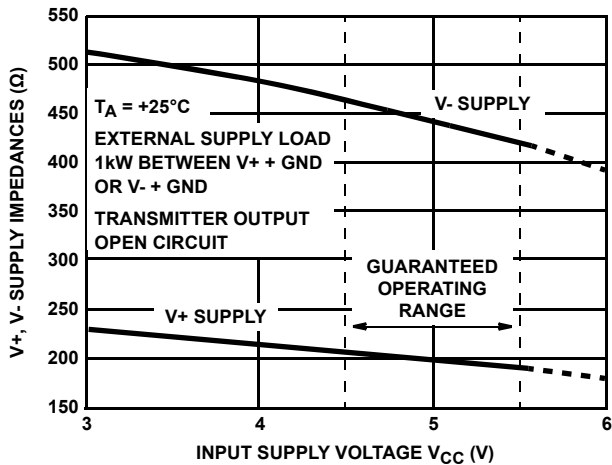

FIGURE 4. V+, V- OUTPUT IMPEDANCES vs VCC

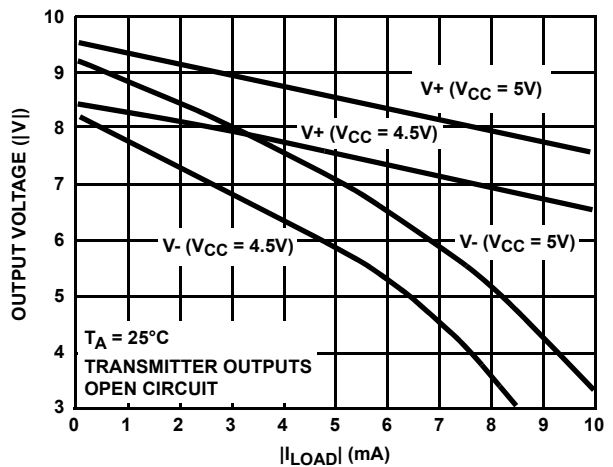

FIGURE 5. V+, V- OUTPUT VOLTAGES vs LOAD CURRENT

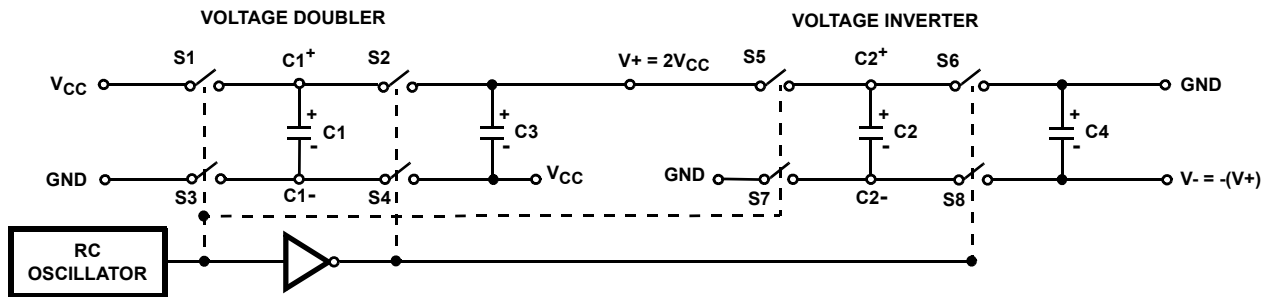

FIGURE 6. DUAL CHARGE PUMP

## Detailed Description

The ICL232 is a dual RS-232 transmitter/receiver powered by a single +5V power supply which meets all EIA RS232C specifications and features low power consumption. [Figure 1](#) illustrates the major elements of the ICL232. The circuit is divided into three sections: a voltage doubler/inverter, dual transmitters, and dual receivers.

### Voltage Converter

An equivalent circuit of the dual charge pump is illustrated in [Figure 6](#).

The voltage quadrupler contains two charge pumps which use two phases of an internally generated clock to generate +10V and -10V. The nominal clock frequency is 16kHz. During phase one of the clock, capacitor C1 is charged to V<sub>CC</sub>. During phase two, the voltage on C1 is added to V<sub>CC</sub>, producing a signal across C2 equal to twice V<sub>CC</sub>. At the same time, C3 is also charged to 2V<sub>CC</sub>, and then during phase one, it is inverted with respect to ground to produce a signal across C4 equal to -2V<sub>CC</sub>. The voltage converter accepts input voltages up to 5.5V. The output impedance of the doubler (V+) is approximately 200Ω, and the output impedance of the inverter (V-) is approximately 450Ω. Typical graphs are presented which show the voltage converters output vs input voltage and output voltages vs load characteristics. The test circuit ([Figure 2](#)) uses 1μF capacitors for C1 to C4, however, the value is not critical. Increasing the values of C1 and C2 will lower the output impedance of the voltage doubler and inverter, and increasing the values of the reservoir capacitors, C3 and C4, lowers the ripple on the V+ and V- supplies.

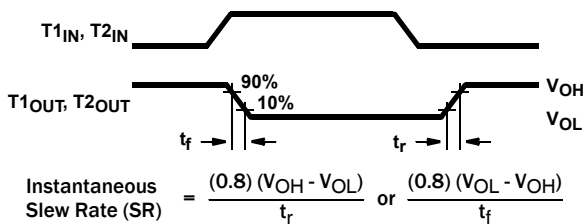

FIGURE 7. SLEW RATE DEFINITION

### Transmitters

The transmitters are TTL/CMOS compatible inverters which translate the inputs to RS-232 outputs. The input logic threshold is about 26% of V<sub>CC</sub>, or 1.3V for V<sub>CC</sub> = 5V. A logic 1 at the input results in a voltage of between -5V and V- at the output, and a logic 0 results in a voltage between +5V and (V+ - 0.6V). Each transmitter input has an internal 400kΩ pullup resistor so any unused input can be left unconnected and its output remains in its low state. The output voltage swing meets the RS-232C specification of ±5V minimum with the worst case conditions of: both transmitters driving 3kΩ minimum load impedance, V<sub>CC</sub> = 4.5V, and maximum allowable operating temperature. The transmitters have an internally limited output slew rate which is less than 30V/μs. The outputs are short circuit protected and can be shorted to ground indefinitely. The powered down output impedance is a minimum of 300Ω with ±2V applied to the outputs and V<sub>CC</sub> = 0V.

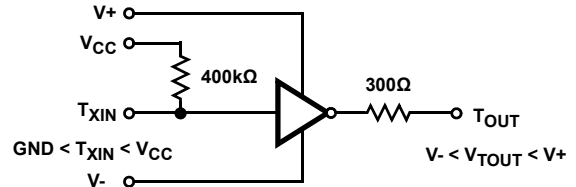

FIGURE 8. TRANSMITTER

### Receivers

The receiver inputs accept up to ±30V while presenting the required 3kΩ to 7kΩ input impedance even if the power is off (V<sub>CC</sub> = 0V). The receivers have a typical input threshold of 1.3V which is within the ±3V limits, known as the transition region, of the RS-232 specification. The receiver output is 0V to V<sub>CC</sub>. The output will be low whenever the input is greater than 2.4V and high whenever the input is floating or driven between +0.8V and -30V. The receivers feature 0.5V hysteresis to improve noise rejection.

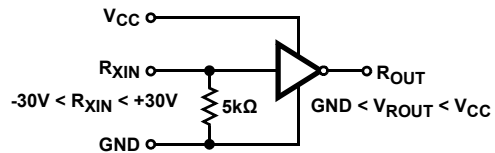

FIGURE 9. RECEIVER

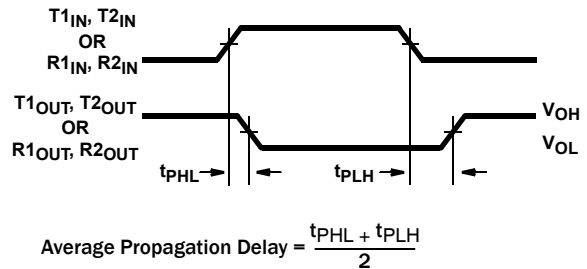

FIGURE 10. PROPAGATION DELAY DEFINITION

## Applications

The ICL232 may be used for all RS-232 data terminal and communication links. It is particularly useful in applications where ±12V power supplies are not available for conventional RS-232 interface circuits. The applications presented represent typical interface configurations.

A simple duplex RS-232 port with CTS/RTS handshaking is illustrated in [Figure 11](#). Fixed output signals such as DTR (data terminal ready) and DSRS (data signaling rate select) is generated by driving them through a 5kΩ resistor connected to V+.

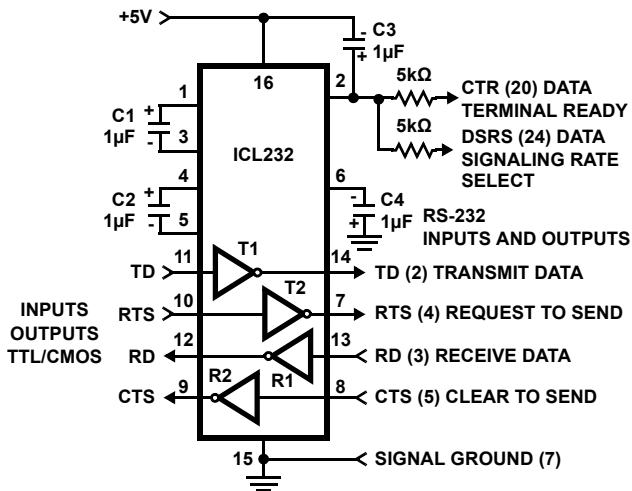

FIGURE 11. SIMPLE DUPLEX RS-232 PORT WITH CTS/RTS HANDSHAKING

In applications requiring four RS-232 inputs and outputs (Figure 12), note that each circuit requires two charge pump capacitors (C1 and C2) but can share common reservoir capacitors (C3 and C4). The benefit of sharing common reservoir capacitors is the elimination of two capacitors and the reduction of the charge pump source impedance which effectively increases the output swing of the transmitters.

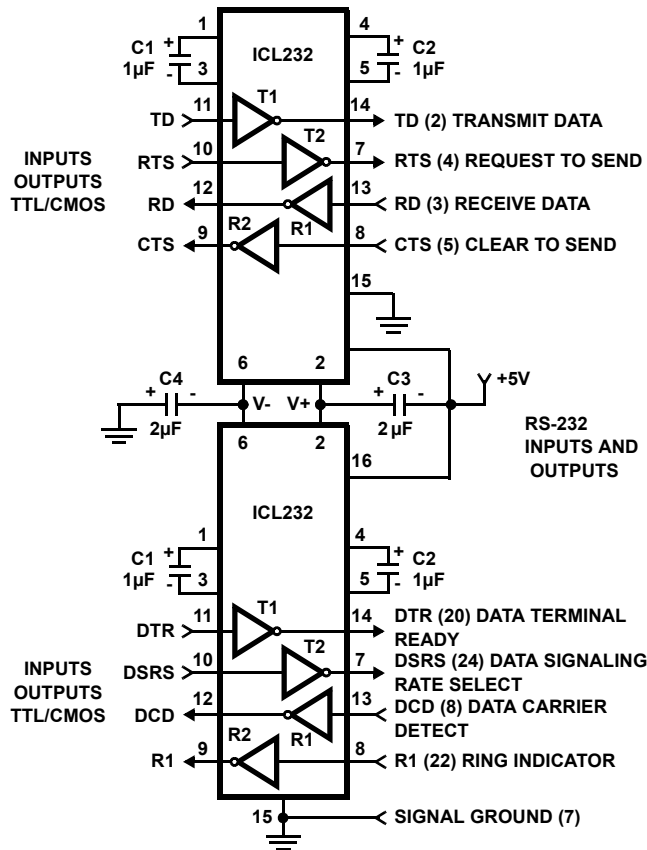

FIGURE 12. COMBINING TWO ICL232s FOR 4 PAIRS OF RS-232 INPUTS AND OUTPUTS

## Revision History

The revision history provided is for informational purposes only and is believed to be accurate, but not warranted. Please go to the web to make sure that you have the latest revision.

DATE	REVISION	CHANGE
October 15, 2014	FN3020.8	<p>Updated the Ordering Information table on page 2 by removing several obsolete products and added Notes 2 and 3.</p> <p>Removed "CERDIP" and "PDIP" from Pin Configuration on page 2.</p> <p>Removed "ICL232I" and "ICL232M" lines under "Operating Conditions" on page 3.</p> <p>Removed "CERDIP" and "PDIP" lines under "Thermal Information" on page 3.</p> <p>Removed "Ceramic Package" line under "Maximum Junction Temperature" on page 3.</p> <p>Updated datasheet with Intersil new standards throughout entire datasheet.</p> <p>Added Revision history and About Intersil verbiage.</p> <p>Added Package Outline Drawing on page 8.</p>

## About Intersil

Intersil Corporation is a leading provider of innovative power management and precision analog solutions. The company's products address some of the largest markets within the industrial and infrastructure, mobile computing and high-end consumer markets.

For the most updated datasheet, application notes, related documentation and related parts, please see the respective product information page found at [www.intersil.com](http://www.intersil.com).

You may report errors or suggestions for improving this datasheet by visiting [www.intersil.com/ask](http://www.intersil.com/ask).

Reliability reports are also available from our website at [www.intersil.com/support](http://www.intersil.com/support)

© Copyright Intersil Americas LLC 2001-2014. All Rights Reserved.  
All trademarks and registered trademarks are the property of their respective owners.

For additional products, see [www.intersil.com/en/products.html](http://www.intersil.com/en/products.html)

Intersil products are manufactured, assembled and tested utilizing ISO9001 quality systems as noted in the quality certifications found at [www.intersil.com/en/support/qualandreliability.html](http://www.intersil.com/en/support/qualandreliability.html)

*Intersil products are sold by description only. Intersil may modify the circuit design and/or specifications of products at any time without notice, provided that such modification does not, in Intersil's sole judgment, affect the form, fit or function of the product. Accordingly, the reader is cautioned to verify that datasheets are current before placing orders. Information furnished by Intersil is believed to be accurate and reliable. However, no responsibility is assumed by Intersil or its subsidiaries for its use; nor for any infringements of patents or other rights of third parties which may result from its use. No license is granted by implication or otherwise under any patent or patent rights of Intersil or its subsidiaries.*

For information regarding Intersil Corporation and its products, see [www.intersil.com](http://www.intersil.com)

**Small Outline Plastic Packages (SOIC)**

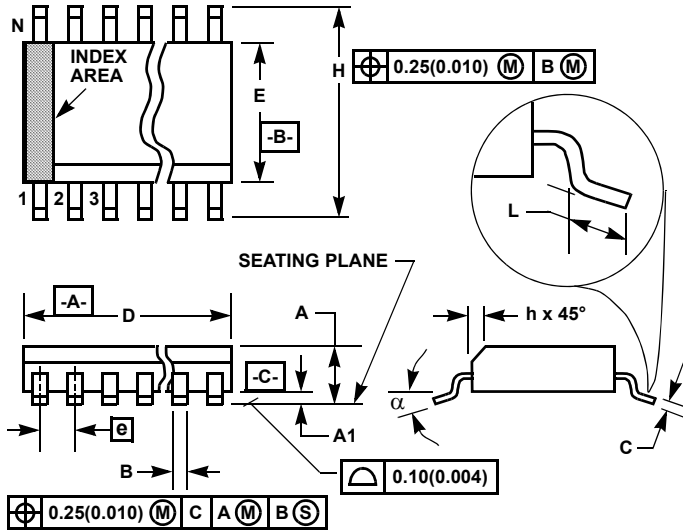

**M16.3 (JEDEC MS-013-AA ISSUE C)  
16 LEAD WIDE BODY SMALL OUTLINE PLASTIC PACKAGE**

SYMBOL	INCHES		MILLIMETERS		NOTES
	MIN	MAX	MIN	MAX	
A	0.0926	0.1043	2.35	2.65	-
A1	0.0040	0.0118	0.10	0.30	-
B	0.013	0.0200	0.33	0.51	9
C	0.0091	0.0125	0.23	0.32	-
D	0.3977	0.4133	10.10	10.50	3
E	0.2914	0.2992	7.40	7.60	4
e	0.050 BSC		1.27 BSC		-
H	0.394	0.419	10.00	10.65	-
h	0.010	0.029	0.25	0.75	5
L	0.016	0.050	0.40	1.27	6
N	16		16		7
alpha	0°	8°	0°	8°	-

**NOTES:**

1. Symbols are defined in the "MO Series Symbol List" in Section 2.2 of Publication Number 95.
2. Dimensioning and tolerancing per ANSI Y14.5M-1982.
3. Dimension "D" does not include mold flash, protrusions or gate burrs. Mold flash, protrusion and gate burrs shall not exceed 0.15mm (0.006 inch) per side.
4. Dimension "E" does not include interlead flash or protrusions. Interlead flash and protrusions shall not exceed 0.25mm (0.010 inch) per side.
5. The chamfer on the body is optional. If it is not present, a visual index feature must be located within the crosshatched area.
6. "L" is the length of terminal for soldering to a substrate.
7. "N" is the number of terminal positions.
8. Terminal numbers are shown for reference only.
9. The lead width "B", as measured 0.36mm (0.014 inch) or greater above the seating plane, shall not exceed a maximum value of 0.61mm (0.024 inch)
10. Controlling dimension: MILLIMETER. Converted inch dimensions are not necessarily exact.

Rev. 1 6/05

## Looking for pricing, stock, or lifecycle information?

Click below to explore more details on WIN SOURCE:

 [View ICL232MJE on WIN SOURCE](#)

 [Intersil Information](#)

## Optimize Your Supply Chain with WIN SOURCE Solutions

-  Global Sourcing Solution
-  Obsolete Management
-  Cost Control Management
-  Shortage Management
-  Alternative Solution
-  Excess Inventory Management